

2020 SPRING SESSIONS

January 13 – May 22, 2020
18-Week Session

January 13 – May 1, 2020
1st 15-Week Session

January 13 – March 13, 2020
1st 9-Week Session

February 3 – May 22, 2020
15-Week Intrasession

March 23– May 22, 2020
2nd 9-Week Session



Spring 2020

Cerritos Community College District
11110 Alondra Blvd., Norwalk, CA 90650
562-860-2451 | www.cerritos.edu



Class Schedule



www.cerritos.edu

MESSAGE FROM THE PRESIDENT



Welcome to the Spring Semester! I hope you are as excited as I am to start the academic year.

Whether you plan to head into the workforce or transfer to a four-year university, the next phase of your life will begin when you enroll here as a Cerritos College student. We have been recognized nationally for our innovation and commitment to student success, and our dedicated faculty and staff are here to help you navigate college life and meet your goals. We offer a comprehensive range of student support services and resources designed to help you succeed, and there are many ways to become involved in campus life through student clubs and leadership opportunities.

We strive to meet the needs for the intellectual, social, ethical, professional, cultural, and creative facets of students' lives. You can take one class or a full load of 12 units. You can learn in our classrooms and laboratories, or you can take courses online. We want to prepare you for the future so that the skills you learn today will support you tomorrow.

Thank you for considering us. If you are already part of our family, I hope you're enjoying your experience. I look forward to you joining us here at Cerritos, and hope to shake your hand when you earn your diploma.

Sincerely,

Dr. Jose L. Fierro
President/Superintendent

OUR MISSION

Cerritos College values its diverse student population and is committed to providing these students with high quality, comprehensive, instructional programs and support services that improve student success and offer clear pathways to achieve personal, educational, and career goals. In doing so, the college develops in students the knowledge, skills, and values that prepare them to be productive participants in the global community.

SERVING THE COMMUNITIES OF

Artesia, Bellflower, Cerritos, Downey,
Hawaiian Gardens, La Mirada, Norwalk



AND PORTIONS OF

Bell Gardens, Lakewood, Long Beach,
Santa Fe Springs, South Gate

CERRITOS COMMUNITY COLLEGE DISTRICT ADMINISTRATION

JOSE L. FIERRO, D.V.M., Ph.D.
President/Superintendent

RICK MIRANDA
Vice President of Academic Affairs/Assistant Superintendent

FELIPE R. LOPEZ
Vice President of Business Services/Assistant Superintendent

ADRIANA FLORES-CHURCH, Ed.D
Vice President of Human Resources/Assistant Superintendent

DILCIE PEREZ, Ed.D
Vice President of Student Services/Assistant Superintendent

BOARD OF TRUSTEES

CARMEN AVALOS
President

MARISA PEREZ
Vice President

MARTHA CAMACHO-RODRIGUEZ
Clerk

JAMES CODY BIRKEY
Member

ZURICH LEWIS
Member

DR. SHIN LIU
Member

DR. SANDRA SALAZAR
Member

VALERY ESCOBAR
Student Trustee

In accordance with the Americans with Disabilities Act, this information is available in alternate formats (Braille, enlarged type, e-text, etc.) and may be requested by calling (562) 860-2451, Ext. 2335.

ALPHABETICAL TABLE OF CONTENTS

Cerritos Community College District

Academic Information	20-22
Admission and Enrollment of Dual Enrolled Minors	30
Admission and Orientation	6, 7
Adult Education Non-Credit Classes	99-106
Alcohol and Drug Policy	144
(ASCC) Associated Students of Cerritos College Rights/Responsibilities/Policies	132-143
Attendance and Grading	28
Auditing of Courses	22
Calendar of Important Dates	3
Campus Map	147
Campus Phone Extensions	145
Chicano Studies	107
Class Listings	32-98
Counseling and Follow-up	9
Course Listings	148
Course Repeatability	26-27
Credit by Exam	23
Disabled Student Programs and Services	130
Distance Education Courses	111-116
Enrollment Instructions	15
Enrollment Appointment Priority	4-5
Family Educational Rights and Privacy Act (FERPA)	118
Fees/Refund Information and Procedures	19
Final Exam Schedule	146
Financial Assistance	29
General Education Requirements for the AA Degree and for Transfer to the CSU and UC	119-125
Información en Español	10-14, 129
International Student Services	31
Learning Communities	110
Northwood University	17
Pass/No Pass Classes	24-25
Paying your Fees	16
Reading the Class Schedule	18
Scholars' Honors Program	108
Services for Students	126-128
Sexual and Gender-Based Misconduct	117
Site Locations (off campus)	105
SRT/Placement	8
Student Services and Policies	132-143
Student Success and Support Program (SSSP)	4-6
Success Center	131
Transfer Center Timeline	149
Wait List	17
Women's and Gender Studies	109

CLASS SCHEDULE

32 – 98

GENERAL CLASS LISTINGS

- General Class Listings 32-93
- Short-Term Classes 94-98
- Weekend Classes 98

99 – 106

ADULT EDUCATION NON-CREDIT CLASSES

- Apprenticeship Programs
Firesprinklers, Painters, and Ironworkers
- Pre-Apprenticeship
- Adult Education
 - ESL
 - VESL
 - Basic English (College English Skills)
 - Basic Math (Preparatory Mathematics)
 - High School Equivalency
 - Literacy Skills for General Education
Development (GED) Success
 - Supplemental General Education
Development (GED) Math
 - Spanish Literacy Skills for General
Education Development (GED) Success
 - Spanish Supplemental General
Education Development (GED) Math
 - Occupational Preparation
 - Citizenship
 - College Math Support
 - College English Support
- Introduction to Energy Surveying
- Introduction to Automotive Tools and
Equipment
- Courses for Older Wiser Learner
- Plaza Community (Spanish Literacy)

110

LEARNING COMMUNITIES

112 – 116

DISTANCE EDUCATION COURSES

*From science to technology to
the humanities, at Cerritos College,
our focus is teaching, learning
and academic excellence.*

If you have questions or need information in Spanish about Cerritos College, please call the Admissions and Records Office at (562) 860-2451, extension 2211. Office hours are Monday through Thursday, 8 am – 7 pm; Friday, 8 am – 2 pm. Additional information is available in Spanish on pages 10-14 and 129.

Si usted tiene preguntas o necesita información en español acerca del Colegio de Cerritos, llame por favor a la Oficina de Admisiones y Registro al número (562) 860-2451, extensión 2211. El horario de oficina es Lunes a Jueves, 8 am – 7 pm; Viernes, 8 am – 2 pm. Información adicional está disponible en español en las páginas 10-14 y 129.

SPRING 2020 CALENDAR OF IMPORTANT DATES

ENROLLMENT BEGINS OCTOBER 21, 2019

For information on assignment of enrollment priorities, please refer to the section titled, "Enrollment Appointment Priority" in this schedule of classes.

MYCERRITOS ENROLLMENT HOURS:	
Monday – Sunday	12 am – 12pm
Sunday	8 am – midnight
MYCERRITOS APPLICATION HOURS:	
Monday – Sunday	12 am – 12pm
ADMISSIONS AND RECORDS OFFICE FEE PAYMENT HOURS:	
Monday – Thursday	8 am – 6:30 pm
Friday	8 am – 11:30 am

**Session Dates and Deadlines are now available online at:
cms.cerritos.edu/admissions-and-records/add-drop-dates**

IMPORTANT DATES:	
First day to file a petition for A.A. Degree and Certificate for Spring 2020	January 13
Dr. Martin Luther King Birthday Observance	January 20
Lincoln's Birthday Observance	February 14
Washington's Birthday Observance	February 17
Last day to file petition for May Commencement	February 21
Spring Recess (<i>Hours of operation during Spring Recess: Mon.-Thurs., 8:00 am-4:00 pm; closed on Friday</i>)	March 16 – 20
Last day to file petition for A.A. Degree and Certificate for Spring 2020	March 27
Final Exams	May 16 – 22

CERRITOS COLLEGE OFFERS APPLICATION AND ENROLLMENT VIA THE WEB.

For Online Submission of Admissions Applications:
Visit www.cerritos.edu. Click on "Apply Now" in the yellow box in the upper right corner.

For Online Enrollments:
Visit www.cerritos.edu. Under the "Current Students" section, click on "**MyCerritos**". Then, click on "Student Center"; or, using Quick Links, click on "MyCerritos", log in, and click on "Student Center" to continue.

*An application must be submitted for new, returning, and transfer students prior to enrollment. For continuing students, a user ID number (7-digit student ID-example 0123456) and Password (6-digit date of birth-mmddyy) are required.

EMERGENCY INFORMATION

In the event of an emergency, the Cerritos College Emergency Information web page (<http://www.cerritoscollege.us/>) may be used to secure updated information about any emergency event occurring on the Cerritos College campus. The College also offers an SMS-based emergency notification service for mobile phones. In the event of an emergency, Cerritos students, staff, faculty, and others will be alerted in real-time to important security information. You may sign-up for Emergency Text Alerts by texting the keyword "CERRITOS" to 226787.

DISCLAIMER

Cerritos College has made reasonable efforts to ensure the accuracy of the information contained in this Schedule of Classes at the time of publication. The College reserves the right to add to, amend, or repeal any of the rules, regulations, policies and procedures, or any other content, consistent with applicable regulations and laws. Content is subject to change without notice by the administration for reasons of student enrollment, level of financial support, or for any other reason at the discretion of the College. The Schedule of Classes does not constitute a contract or the terms of a contract. The Schedule of Classes is not intended to promulgate all policies, procedures, rules, and regulations of partner organizations, transfer institutions, the College, or the Cerritos Community College District. Students are advised to consult the online version of this schedule of classes and to contact Counseling Services or the applicable administrative office for additional information.

ANNUAL SECURITY REPORT

Cerritos College publishes an Annual Security Report in accordance with the Clery Act. This report includes statistics for the previous three years concerning reported crimes that occurred on-campus; in certain off-campus buildings or property owned or controlled by Cerritos College; and on public property within, or immediately adjacent to and accessible from, the campus. This report also includes institutional policies concerning campus security, such as policies concerning sexual assault, and other matters. You can obtain a copy of this report by contacting the Campus Police Department in person or at (562) 860-2451, extension 3202. This report is also available on the college website at www.cerritos.edu/securityreport.

STUDENT SUCCESS AND SUPPORT PROGRAM (SSSP)

Information is also available in Spanish on pages 10-14.

Información en español también está disponible en las páginas 10-14.

STUDENT RIGHTS AND RESPONSIBILITIES

- (a) All students shall be required to:
 - (1) identify an education and career goal;
 - (2) diligently engage in course activities and complete assigned coursework; and
 - (3) complete courses and maintain progress toward an education goal and completing a course of study.
- (b) Nonexempt first-time students shall, within a reasonable period of time, be required to:
 - (1) identify a course of study;
 - (2) be assessed to determine appropriate course placement;
 - (3) complete an orientation provided by the college;
 - (4) participate in counseling, advising, or another education planning service to develop an abbreviated student education plan (A-SEP).
- (c) For the purposes of this section, a first time student is a student who enrolls at the college for the first time, excluding students who transferred from another institution of higher education. For the purposes of this section, first time enrollment does not include concurrent enrollment during high school. To the extent that a college has the capacity to require and provide the services identified in (b)(1) through (4) to other students, nothing in this section would preclude a college from doing so.
- (d) Nonexempt students who have completed the services identified in (b)(1) through (4) shall be required to complete a comprehensive student education plan (C-SEP) after completing 15 semester units of degree applicable credit course work or prior to the end of the 3rd semester, or a shorter period if required by district or program policy.
- (e) Failure to fulfill the required services listed in (b) may result in a hold on a student's registration or loss of registration priority until the services have been completed.

INSTITUTIONAL RESPONSIBILITIES

- (a) The college shall take steps to ensure that information regarding matriculation policies is accessible and available to all students during, or prior to, enrollment (e.g. during orientation) and is included in class schedules, catalogs, or other appropriate communications describing student rights and responsibilities.
- (b) Once the student has identified a course of study and completed 15 semester units of degree applicable course work, the college shall provide the student with an opportunity to develop a comprehensive student education plan (C-SEP) within a reasonable time period. Student responsibilities shall also be identified in the student's education plan.
- (c) College policy provides that a nonexempt student will have a hold placed on enrollment if a student fails to fulfill the responsibilities set forth in the section, "Student Rights and Responsibilities".
- (d) The college shall make reasonable efforts to avoid duplication of the orientation, assessment, counseling, advising, or other education planning services, and development of student education plans funded through this subchapter or funded through other programs.

- (e) It is intended that the instructional and student services area of the college shall use multiple sources of data from student education planning efforts and identified courses of study to coordinate course scheduling.

ENROLLMENT APPOINTMENT PRIORITY

including Orientation, SRT, Counseling, Student Education Plans, Tier Groups, Probation

The purpose of establishing enrollment priorities is to support students endeavoring to reach their educational goals at Cerritos College by providing priority enrollment to groups of students (as listed herein) with special needs and/or who are in continuing student status, as long as satisfactory progress is made.

PRIORITY ENROLLMENT CRITERIA AND CONDITIONS

- A. Priority
 - 1. New students not otherwise exempt, including those in any state-provided priority enrollment groups, must complete SRT, orientation, and counseling with at least an abbreviated student education plan (A-SEP), in order to receive priority enrollment.
 - 2. First-time students, beginning with Spring 2020 enrollment, who have identified a course of study, been assessed to determine appropriate course placement, completed an orientation program provided by the college, and participated in counseling, advising, or another education planning service including at least an abbreviated student education plan (A-SEP), are required to complete a comprehensive student education plan (C-SEP) after completing 15 units of degree-applicable credit course work, or prior to the end of the 3rd semester of enrollment, resources permitting.
 - 3. Continuing students, including those in any state-provided priority enrollment groups, except eligible current and former foster youth, are subject to loss of the enrollment priority for which they would ordinarily be eligible if they are on any combination of progress or academic probation for two consecutive semesters.
 - 4. Continuing students, including those in any state-provided priority enrollment groups, except eligible current and former foster youth, are subject to loss of the enrollment priority for which they would ordinarily be eligible if they have earned 100 degree-applicable, non-basic skills and non-ESL units. Units for high unit majors and programs may be disregarded to the extent they exceed the number of units required for non-high unit majors and programs. Units from Credit by Exam, Advanced Placement, International Baccalaureate, or other similar programs may also be exempted.
- B. Subject to the above, continuing student enrollment appointments shall be set on the basis of units earned and cumulative grade point average at Cerritos College.
- C. Students subject to enrollment priority exclusion shall have a "PRB" negative service indicator, appearing as a Hold in the Student Center in MyCerritos, placed on their enrollment account. The effect shall be to place the student's access to enroll at the end of the enrollment cycle in the period known as Open Enrollment.

STUDENT SUCCESS AND SUPPORT PROGRAM (SSSP)

- D. Students excluded from enrollment priority shall be notified of options they may have, and/or are advised to exercise. See also the section of this procedure titled "Appeals and Exemptions".

Additional Criteria for Enrollment Priority of Certain Students

- A. Students who are otherwise specified by statute.
- B. Students whose instructional program requires time off-campus or blocks of time associated with scheduled classes for such activities as practice, meetings, counseling, and off-campus time, which limit the choice of class periods.

STUDENT GROUPS WITH PRIORITIES:

Tier 1: Enrollment appointments for students in Tier 1 groups shall be set tier-wide based on units earned and cumulative grade point average, consistent with applicable regulations.

Armed Forces Personnel and Recent Veterans: Students who are any member or former member of the Armed Forces of the United States, who is a resident of California, for any academic term, within four years of leaving active duty (Education Code Section 66025.8).

CalWORKs: Students formally enrolled in the CalWORKs Program (Education Code Section 66025.92).

DSPS: Students who, by their specific disabilities, are enrolled in Disabled Student Programs and Services (Education Code Section 66025.91).

EOPS: Students formally enrolled in Extended Opportunity Programs and Services (Education Code Section 66025.91).

Foster Youth: Students formally deemed eligible current or former foster youth who are up to and including 24 years of age (Education Code Section 66025.9).

Tier 2: Enrollment appointments for students in Tier 2 groups shall be set tier-wide based on units earned and cumulative grade point average, consistent with applicable regulations.

Scholars' Honors Students: Students who have been officially admitted to the College's Scholars' Honors Program each term and are currently enrolling in Scholars' Honors Program courses and/or Scholars' Honors contracts.

Student Athletes: Students who have been identified as eligible to participate in intercollegiate athletics.

Mandatory Enrollment Requirement Students: Students in compliance with program requirements who must maintain full-time status, with completion time requirements, in order to remain in Cerritos College programs and/or who are in grant-funded programs with enrollment priority requirements.

Matriculated Students: Students who, prior to their first semester of enrollment, completed the Admission, Orientation, Assessment, and Counseling components of Matriculation.

Trial, Grant-funded, or Other Special Groups for Student Success: Students in groups identified for enhanced and/or expedited student success measures where trial, grant-funded, and/or other special, short-term measures are employed.

Tier 3: Enrollment appointments for students in Tier 3 groups shall be set in the order of the groups as listed and based on units earned and cumulative grade point average within those groups, consistent with applicable regulations.

Continuing Students: Students who were enrolled in the previous academic year or summer session. Students who do not attend summer session will not lose continuing student status. The definition includes non-credit students who are matriculating to credit student status.

Returning Students: Students who have completed at least one unit of credit at Cerritos College and are returning after a break of no more than one semester excluding summer session.

Tier 4: Enrollment appointments for students in Tier 4 groups shall be set in the order of the groups as listed and based on units earned and cumulative grade point average within those groups, consistent with applicable regulations.

Dual Enrollment: High school juniors and seniors, as provided for and limited in, Board Policy 5010 titled "Admissions and Concurrent Enrollment" and Administrative Procedure 5011 titled "Admission and Concurrent Enrollment of High School and Other Young Students".

Dual Enrollment (Grades K-10): Talented elementary and secondary students through the 10th grade, as provided for and limited in, Board Policy 5010 titled "Admissions and Concurrent Enrollment" and Administrative Procedure 5011 titled "Admission and Concurrent Enrollment of High School and Other Young Students".

ENROLLMENT LIMITATIONS

Enrollment in courses and programs may be limited to students meeting properly established prerequisites and co-requisites (See Board Policy and Administrative Procedure 4260 titled "Prerequisites and Co-requisites").

Additional Enrollment Limitations (including, but not limited to):

- A. Health and safety considerations;
- B. Faculty workload;
- C. Availability of qualified instructors;
- D. Funding limitations;
- E. Regional planning;
- F. Legal requirements;
- G. Facility limitations; and
- H. Accreditation, regulatory, and policy requirements.

Priorities When Enrollment Must be Limited

- A. First come, first served, or other non-evaluative selection techniques, provided all prerequisite and/or course requisites have been met;
- B. In the case of intercollegiate competition, honors courses, or public performance courses, allocating available seats to those students judged most qualified;
- C. Limiting enrollment to any selection procedure expressly authorized by statute; and
- D. Limiting enrollment in one or more sections to students enrolled in one or more other courses, provided that a reasonable percentage of all sections of the course do not have such restrictions.

Additional Conditions May Be Applicable to Order of Enrollment

Course sections funded other than by state apportionment, such as contract education, grant-funded programs, and certain fee-based sections (as permitted by law).

STUDENT SUCCESS AND SUPPORT PROGRAM (SSSP)

LOSS OF ELIGIBILITY FOR CCPG FEE WAIVER

A student shall become ineligible for a California College Promise Grant (CCPG) Fee Waiver if the student is placed on academic or progress probation, or any combination thereof, for two consecutive primary terms. Loss of eligibility shall become effective at the first registration opportunity after such determination is made.

The District shall notify students of their placement on academic or progress probation no later than 30 days following the end of the term that resulted in the student's placement on probation. The notification must clearly state that two consecutive primary terms of probation will lead to a loss of the CCPG Fee Waiver until the student is no longer on probation. The notification must also advise students about the available student support services to assist them in maintaining eligibility.

The District shall adopt, prominently display, and disseminate policies ensuring that students are advised about the student support services available to assist them in maintaining and re-establishing CCPG Fee Waiver eligibility. Dissemination includes, but is not limited to, information provided in college catalogs and class schedules.

The District shall establish written procedures by which a student may appeal the loss of a CCPG Fee Waiver due to extenuating circumstances, or when a student with a disability applied for, but did not receive, a reasonable accommodation in a timely manner. Extenuating circumstances are verified cases of accidents, illnesses, or other circumstances that might include documented changes in the student's economic situation or evidence that the student was unable to obtain essential student support services. Extenuating circumstances also include special consideration of the specific factors associated with Veterans, CalWORKs, EOPS, and DSPS student status.

Foster Youth shall not be subject to loss of CCPG Fee Waiver due to placement on academic or progress probation. This exemption for Foster Youth is effective until the date specified in the Education Code, section 66025.9(c).

APPEALS AND EXEMPTIONS

It is the intent of these procedures to support and promote student success, including program completion, through access to needed courses. Petitions for appeals of, or exemption from, the implementation of these procedures are subject to consideration by the Committee on Academic Records and Standards (A&S) or its designee.

- A. Students may appeal the loss of enrollment priority and/or loss of the CCPG Fee Waiver due to extenuating circumstances, certain conditions specified on the Enrollment Priorities and/or the CCPG Fee Waiver Appeals Form, or where a student with a disability applied for, but did not receive reasonable accommodation in a timely manner. Extenuating circumstances are verified cases of accidents, illnesses, or other circumstances beyond the control of the student.
- B. Students who have demonstrated significant academic improvement will regain the CCPG Fee Waiver and/or priority enrollment status. It is the student's responsibility to timely verify changes in enrollment priority status. Significant academic improvement is defined as achieving no less than the minimum grade point average and progress standard within a term. The minimum academic standard is a 2.0 grade point average, once the student has attempted 12 semester units; the minimum progress standard is greater than 50% of all units enrolled in being other than "W", "I", "NP", or "NC", once the student has enrolled in a total of at least 12 semester units.
- C. Students may request reinstatement of enrollment priority and/or the CCPG Fee Waiver if an institutional mistake was made.

ADMISSION AND ORIENTATION

ASSESSMENT AND ORIENTATION-COUNSELING ARE REQUIRED FOR FIRST-TIME, NEW-TO-COLLEGE STUDENTS.

ADMISSION

Who May Apply for Admission?

- Anyone who is a high school graduate or at least 18 years of age who may benefit from instruction.
- High school students in their junior or senior year with appropriate Dual Enrollment approval forms.
- International Students in valid, non-immigrant, F-1 visa status.

How to Apply for Admission

- Students who are enrolling for the first time or who are returning after an absence of one or more semesters, must complete an admissions application as early as possible prior to the start of enrollment (proof of residence may be required). The admission application is available on the college website at www.cerritos.edu, "Apply Now".
- **International students who are outside the U.S. seeking I-20 and inside the U.S. with F-1 visa status planning to transfer to Cerritos College.** International students must submit an International Student application, meet specific admission requirements, and pay a \$50 processing fee. Please see page 30 for admission requirements.

Prerequisites are strictly enforced by MyCerritos enrollment. Read your course selections carefully for all requirements. Requisites may be fulfilled by:

- *Completing placement tests and enrolling in the recommended courses, and/or*
- *Completing the prerequisite course with a grade of Pass, or "C" or higher.*

OR

- *By submitting transcripts to the Admissions and Records Office if a prerequisite course was completed at another college.*

Requisite Clearance forms for consideration for the current semester should be submitted two weeks prior to the start of enrollment.

ADMISSION AND ORIENTATION

ORIENTATION

SRT/Placement and Orientation-Counseling are required for all first-time, new-to-college students. Transfer students are also highly encouraged to complete orientation.

SRT/Placement and Orientation-Counseling

Placement and orientation counseling are required for first-time, new-to-college students. Two holds will appear in the MyCerritos account of these students: one hold for SRT/Placement (ASM) and one hold for Orientation-Counseling (ORI). **Enrollment in classes will not be allowed until these requirements are met.** Students not required to complete the established criteria are automatically exempt upon application to the College.

Early Success Program (ESP)

Cerritos College offers the Early Success Program (ESP) during the fall and spring semesters. This program is designed to encourage early completion of SRT/Placement and Orientation-Counseling. By completing SRT/Placement and Orientation-Counseling prior to the established deadline, first-time college students receive an earlier enrollment appointment date. For more information, visit www.cerritos.edu/esp.

Options for New Student Orientations

Online

Start, stop, and restart anytime! Go to www.cerritos.edu, log in to MyCerritos, and click *Cerritos College New Student Orientation*.

On campus

A limited number of orientations are offered, including day and evening, prior to the start of each term. Call the Counseling Office at (562) 467-5231, or go online to www.cerritos.edu/aoc, for more information.

STUDENT ACTIVITY STICKER AND IDENTIFICATION CARD

ASCC utilizes the revenue collected from the Student Activity fee to support academic, extra-curricular, and student life programs, services, and events.

A student activity sticker and identification card can be obtained from the Student I.D. Center, which is located in the Admissions and Records Office in the Administration Building.

REGULAR HOURS

During fall and spring semesters: 8 am – 7 pm, Monday through Thursday; 8 am – 2 pm, Friday. Hours vary during summer sessions. For more information or current hours, call the Student I.D. Center at (562) 860-2451, ext. 2211.

If a student has special circumstances and cannot be available to obtain the student activity sticker and identification card during any of the hours listed above, arrangements can be made by calling (562) 860-2451, ext. 2211.

It is important that students be in possession of their Cerritos College identification card at all times while on campus. This card is necessary for “buy-backs” in the College Bookstore and it is important to present when using the College Library and Student Health Center.



SRT/PLACEMENT

WHAT IS THE PLACEMENT PROCESS?

Placement is required for first-time, new-to-college students. “Placement” means the process of gathering information about an individual student to facilitate his or her success. At Cerritos College, the process includes, but is not limited to, the collection of information regarding a student’s study skills, English language proficiency, and/or computational skills. Academic counselors will review high school and/or college transcripts, evidence of an A.A. degree or higher from an accredited institution, learning skills, academic performance, and need for special services.

DO I NEED TO COMPLETE THE PLACEMENT PROCESS?

As of Fall 2019, all students will have the opportunity to place into transfer-level English and math. By using high school records or guided self-placement, new and continuing students will identify the English/ESL and math courses they are eligible to enroll in.

First-time, new-to-college students are required to complete the placement process prior to enrollment. Continuing students who have been placed into a math course below Math 80 or English 100 are welcome to complete this new placement process.

Depending on when, where, or if students attended high school, they will complete either the Self-Report Tool (SRT) or Guided Placement Tool (GPT), which, in most cases, will place students directly into transfer-level courses in the areas of math and English, or ESL. A current Cerritos College student number and photo ID are required to complete the SRT or GPT.

How do you complete the SRT or GPT? Visit the Assessment Center in MP 206 or online at www.cerritos.edu/assessment-center/ to get started.

Students with a history of special education are encouraged to seek additional course placement guidance from counselors in Disabled Student Programs and Services. Visit www.cerritos.edu/dsps/ for more information.

STUDENT SUCCESS & SUPPORT PROGRAM (SSSP) EXEMPTION/EXCEPTION

Cerritos Community College offers Student Success and Support Services to all new students prior to their enrollment in classes. These services include placement, orientation, and counseling. First-time, new-to-college students must complete required SRT/Placement and Orientation-Counseling prior to enrollment. Students not required to complete the requirements under established criteria are automatically exempt upon application to the College. Students wishing to pursue another type of exemption must submit a completed Student Success and Support Program (SSSP) Exemption and Exception form to the Admissions and Records Office. SSSP Exemption and Exception forms are available in the Admissions and Records, Assessment, and Counseling Offices. If you have special needs for completing SRT/ placement, orientation, or counseling; please contact the Assessment Office or Disabled Students Programs and Services.

SRT/PLACEMENT EXEMPTIONS

Students who already possess an AA degree or higher from a regionally accredited college are not required to complete the SRT/ placement process, but will be required to verify the degree by presenting official documents to the Admissions and Records Office at least 10 working days prior to their enrollment appointment date. A Requisite Clearance form must accompany the documents in order to meet prerequisites.

PLACEMENT EXEMPTIONS FOR:

English – Students who have completed English courses at another college may not need to complete the English SRT. Please submit proof (official or unofficial transcripts) and a Requisite Clearance form to a counselor or Admissions and Records prior to enrollment.

Math – Students who have completed math courses at another college also may not need to complete the math SRT. Please submit proof (official or unofficial transcripts) and a Requisite Clearance form to a counselor or Admissions and Records prior to enrollment. It is strongly recommended that these math courses have been completed within the past 10 years.

Advanced Placement Exams – Students who participate in advanced placement courses at their high schools and earn passing scores on AP exams may earn college credit for those courses when they come to Cerritos College. For further details, ask a counselor.

Chemistry – Please read the prerequisites and recommendations section with each chemistry class listing. Be sure that the prerequisites are satisfied before enrolling in a course.

Please note: The exceptions listed are assessment/ placement options for course clearance or placement. To meet the required reading, math, and English proficiencies necessary to qualify for the Associate in Arts degree, check your catalog or ask a counselor.

ACCOMMODATION FOR ENGLISH AS A SECOND LANGUAGE

Students planning to take ESL (English as a Second Language) courses may need to take the ACCUPLACER ESL test. Upon completion of the SRT, students will receive a recommendation to take the ACCUPLACER ESL test when appropriate. Students may still take the ACCUPLACER ESL test if the student believes they would benefit from ESL instruction. For questions regarding the best path of instruction, please meet with a counselor.

RETEST POLICY

Students who have completed the ACCUPLACER test and wish to retest, will now complete the Self-Reporting Tool (SRT). Students who have completed high school within the last 10 years, will receive course recommendations based on their United States high school records. Based on the cumulative and unweighted United States high school GPA and other academic-related questions, students may be placed directly into transfer level courses in the areas of English, reading, math, or ESL. A current Cerritos College student number and photo ID are required to complete the SRT, which is computerized. For students who completed high school more than 10 years prior to applying to the college, completed the GED or did not complete high school, or are an international student, please contact the Assessment Office for information pertaining to your specific situation.

PLACEMENT SCHEDULE

Copies of the schedule are available on the Cerritos College Assessment Office web page, www.cerritos.edu/assessment-center/; at the Admissions and Records Office, Counseling, and Career Services; or call (562) 860-2451, ext. 2599, for dates and times. For the current schedule, please refer to the web page, as the schedule is subject to change.

ACCOMMODATION FOR STUDENTS WITH DISABILITIES

Any student with a verified disability may arrange accommodations for the placement process. A current Cerritos College application must be on file to receive accommodations. Accommodations requests should be made at least 7 days in advance to Disabled Students Programs and Services (DSPS). For more information or an appointment, call (562) 860-2451, ext. 2335; (562) 274-7164 (VP); or visit our website at www.cerritos.edu/dsps/. Academic Accommodations may include, but are not limited to: readers, writers, or the use of assistive technology.

COUNSELING AND FOLLOW-UP

COUNSELING

- All students new to college are required to complete a new student orientation to receive counselor assistance for course selection prior to enrollment. See the "Orientation" section for more information on required SRT/Placement and Orientation-Counseling. Returning and transfer students are also encouraged to see a counselor.
- Counselors are available both in person and virtually for appointments, or standby/drop-in.
- Students may submit a general question to a counselor online at www.cerritos.edu/counseling.
- Plan ahead – appointments and standby/drop-in counseling may be limited during peak registration.
- Once the semester begins, new, readmit, and transfer students are highly encouraged to make a counseling appointment or attend an Ed Plan workshop to discuss educational goals and to complete a Comprehensive Student Educational Plan (C-SEP).
- Continuing students are encouraged to meet with a counselor every semester to ensure their educational plan accurately reflects their educational goal. Schedule an appointment or sign up for an Ed Plan workshop at the Counseling desk, or call (562) 467-5231.
- Students who are on academic and/or progress probation will be limited in the number of units they may take each semester based upon their GPA and course completion. They also risk losing their enrollment priority appointment and, as of Fall 2016, may be ineligible for the California College Promise Grant Fee Waiver (CCPGFW) if they remain on probation for two consecutive semesters.

FOLLOW-UP

Counseling and teaching faculty provide a number of follow-up services to students. These services are designed to provide information regarding the students' academic progress. Special services are provided to students on academic and/or progress probation, students in basic skills courses, and students who are undecided about their educational goal. Referrals are made to on and off-campus services when appropriate.

BASIC SKILLS COURSE LIMITATIONS

No more than a total of thirty (30) units from the pre-collegiate basic skills courses listed below are allowed:

ENGL 20

MATH 20, 40

READ 41, 42, 43, 46, 48, 49

"Basic skills course work" refers to pre-collegiate basic skills courses (i.e. courses in reading, writing, computation, learning skills, study skills) that are designated as non-degree applicable courses, the purpose of which is to prepare students for successful completion of an Associate in Arts degree, transfer, or certification courses.

Students enrolled in one or more courses of English as a Second Language (ESL) or students identified as having a learning disability are exempt from the thirty (30) unit limitation. A student who has completed thirty (30) units of basic skills course work shall be barred from enrolling in pre-collegiate basic skills classes and referred to other agencies to develop the skills necessary to enter college-level course work.

Open Courses

All courses, course sections, and classes of the College shall be open for enrollment to any person who has been admitted to the College. Enrollment shall be limited to students meeting properly validated prerequisites and co-requisites. Exemptions for state or federal statutes or regulations shall be established and the President/Superintendent shall establish procedures to establish exemptions for other practical considerations.

NEW STUDENT

You are a new student if this is the first time you are attending any college. You are required to complete SRT/Placement and Orientation-Counseling prior to enrollment.

TRANSFER STUDENT

You are a transfer student if you attended another college but have never attended Cerritos College.

RETURNING STUDENT

You are a returning student if you have previously attended Cerritos College but did not attend the 2019 Fall semester.

CONTINUING STUDENT

You are a continuing student if you were enrolled in credit classes at Cerritos College during the 2019 Fall semester.

DUAL ENROLLMENT STUDENT (K-12)

Concurrent enrollment for students who wish to attend Cerritos College while in grades K-12.

**BUY YOUR
BOOKS
WHEN YOU
ENROLL!**

Now you can buy your textbooks during the enrollment process. Just click the "buy books" button in MyCerritos on either of two screens: one when you "Add Classes" and another on "My Class Schedule". The button links to the Cerritos College Bookstore's eFollett website and presents a list of items (if available) that directly relate to your enrolled classes for the term.

PROGRAMAS DE APOYO Y ÉXITO DEL ESTUDIANTE (Student Success and Support Programs, SSSP), anteriormente Matriculación

DERECHOS Y RESPONSABILIDADES DE LOS ESTUDIANTES

- (a) Se debe requerir a los estudiantes que:
 - (1) Identifiquen una meta educativa y profesional.
 - (2) Participen diligentemente en las actividades del curso y completen los trabajos asignados.
 - (3) Completen los cursos y mantengan el progreso hacia un objetivo educativo y concluyan un curso de estudio.
- (b) Los estudiantes de primer ingreso no exentos en un plazo de tiempo razonable, deberán:
 - (1) Identificar un curso de estudio.
 - (2) Realizar una evaluación para determinar la colocación en el curso apropiado.
 - (3) Completar una orientación que establece la universidad.
 - (4) Participar en la consultoría, asesoría u otro servicio de planificación de la educación para desarrollar un plan educativo abreviado.
- (c) A los efectos de esta sección, un estudiante de primer ingreso es un estudiante que se inscribe en la universidad por primera vez, salvo los estudiantes que se transfieren de otra institución de educación superior. Para los propósitos de esta sección, la inscripción por primera vez no incluye la inscripción simultánea cuando todavía se asiste a la escuela secundaria. En la medida en que una universidad tenga la capacidad de exigir y proporcionar los servicios indicados en (b)(1) a (4) a otros estudiantes, nada de lo incluido en esta sección impedirá a la universidad hacerlo.
- (d) Los estudiantes no exentos que hayan cumplido con los servicios identificados en (b)(1) a (4) estarán obligados a terminar un plan de formación integral (C-SEP) después de completar 15 unidades semestrales de los cursos con créditos aplicables al grado académico o antes de finalizar el tercer semestre, o bien en un período más corto si lo requiere una política del programa o del distrito.
- (e) El incumplimiento de realizar los servicios requeridos que se enumeran en (b) puede resultar en una retención del registro del estudiante o la pérdida de la prioridad de inscripción hasta que los servicios se hayan completado.

RESPONSABILIDADES INSTITUCIONALES

- (a) La universidad tomará las medidas necesarias para garantizar que la información sobre las políticas de matriculación sea accesible y está disponible para todos los estudiantes, durante, o antes de, la inscripción (por ejemplo, durante la orientación) y se incluye en los programas de clase, catálogos u otras comunicaciones apropiadas que describen los derechos y las responsabilidades de los estudiantes.
- (b) Una vez que el estudiante ha identificado un curso de estudio y completó 15 unidades semestrales de trabajo del curso aplicables al grado académico, la universidad debe proporcionarle la oportunidad de desarrollar un plan educativo (C-SEP) integral en un plazo razonable. Las responsabilidades estudiantiles también deberán determinarse en el plan de educación del estudiante.
- (c) La política de la universidad establece que un estudiante no exento tendrá una retención de la matrícula si no cumple con las responsabilidades establecidas en la sección “Derechos y responsabilidades de los estudiantes”.

- (d) La universidad hará esfuerzos razonables para evitar la duplicación de la orientación, evaluación, consultoría, asesoría u otros servicios de planificación de la educación y el desarrollo de los planes educativos financiados a través de este subcapítulo o por medio de otros programas.
- (e) Se pretende que el área de servicios estudiantiles y de enseñanza de la universidad utilice diferentes fuentes de datos sobre los esfuerzos de planificación de la educación de los estudiantes y cursos identificados de estudio para coordinar la programación de los cursos.

PRIORIDAD DE LA CITA DE INSCRIPCIÓN

incluye la orientación, evaluación, consultoría, planes educativos, grupos de nivel, período de prueba

El propósito de establecer prioridades de inscripción es apoyar a los estudiantes que se esfuerzan por alcanzar sus metas educativas en Cerritos College, proporcionando prioridad de inscripción a grupos de estudiantes (que se enumeran en este documento) con necesidades especiales o que están en condición de estudiantes de reingreso, siempre y cuando el progreso sea satisfactorio.

CRITERIOS Y CONDICIONES PARA LA PRIORIDAD DE INSCRIPCIÓN

A. Prioridad

1. Los nuevos estudiantes que no se encuentran exentos de otra manera, entre ellos los que son parte de grupos con prioridad de inscripción que establece el estado, deben completar la evaluación, orientación y consultoría con por lo menos un plan educativo abreviado (A-SEP), a fin de recibir prioridad de inscripción.
2. La primera vez, a partir de la inscripción en el otoño de 2014, los estudiantes que han identificado un curso de estudio, se han evaluado para determinar la colocación apropiada de cursos, completaron un programa de orientación que proporciona la universidad y han participado en la consultoría, asesoría u otro servicio de planificación de la educación que incluye, al menos, un plan educativo abreviado (A-SEP), están obligados a completar un plan educativo integral (C-SEP) después de completar 15 unidades semestrales de los cursos con créditos aplicables al grado académico o antes de finalizar el tercer (3.er) semestre de inscripción, según lo permitan los recursos.
3. Los estudiantes de reingreso, incluidos los de algún grupo con prioridad de inscripción que establece el estado, salvo los jóvenes de crianza actual y anterior que son elegibles, están sujetos a la pérdida de la prioridad de inscripción para los que ordinariamente serían elegibles si están en cualquier combinación de progreso o probatoria académica para dos semestres consecutivos.
4. Los estudiantes de reingreso, incluidos los de algún grupo con prioridad de inscripción que establece el estado, salvo los jóvenes de crianza actual y anterior que son elegibles, están sujetos a la pérdida de la prioridad de inscripción para la que ordinariamente serían elegibles si han obtenido 100 destrezas no básicas aplicables al grado académico y que no son unidades del programa ESL. Las unidades para asignaturas y programas principales podrán ignorarse en la medida en que superen el número de unidades requeridas para asignaturas y programas que no son principales. Las unidades de crédito por examen, colocación avanzada, Bachillerato Internacional u otros programas similares también pueden estar exentos.

- B. Sin perjuicio de lo anterior, las citas de matrícula de los estudiantes de reingreso se establecerán con base en las unidades o el promedio de calificaciones acumuladas en Cerritos College.
- C. Los estudiantes que están sujetos a la exclusión de prioridad de inscripción tendrán un indicador de servicio negativo, que aparece como una retención en el Centro estudiantil en MyCerritos, colocado en su cuenta de la matrícula. El efecto será colocar el acceso del estudiante a matricularse al final del ciclo de inscripción en el período conocido como Inscripción Abierta.
- D. Los estudiantes excluidos de la prioridad de inscripción deben recibir notificación de las opciones que tienen o qué se les aconseja ejercer. Vea también la sección de este procedimiento titulada "Apelaciones y Excepciones."

Criteria adicionales para la prioridad de inscripción de determinados estudiantes

- A. Los estudiantes que de otra manera se especifican en el estatuto.
- B. Los estudiantes cuyo programa educativo requiere tiempo fuera del campus o bloques de tiempo asociados con las clases programadas para actividades tales como práctica, reuniones, asesoramiento y tiempo fuera de la escuela, lo que limita la elección de los períodos de clase.

GRUPOS DE ESTUDIANTES CON PRIORIDADES:

Nivel 1: las citas de matrícula para los estudiantes en los grupos del Nivel 1 se programarán en todo el nivel con base en las unidades que han obtenido y el promedio de calificaciones acumuladas de conformidad con la normativa aplicable.

Personal de las Fuerzas Armadas y veteranos recientes: los estudiantes que son miembros o ex miembros de las Fuerzas Armadas de los Estados Unidos, que son residentes de California, por cualquier plazo académico, dentro de los cuatro años siguientes al cese del servicio activo. (Artículo 66025.8 del Código de Educación)

CalWORKs: estudiantes inscritos formalmente en el Programa CalWORKs. (Artículo 66025.92 del Código de Educación)

EOPS: estudiantes matriculados formalmente en los Programas y Servicios de Oportunidad Ampliada (Extended Opportunity Programs and Services, EOPS). (Artículo 66025.91 del Código de Educación)

DSPS: estudiantes que por sus discapacidades específicas están inscritos en Programas y Servicios de Estudiantes Discapacitados (Disabled Students Programs and Services, DSPS) (Artículo 66025.91 del Código de Educación)

Jóvenes de crianza: los estudiantes que se consideran formalmente como jóvenes de crianza actualmente o en el pasado, que son elegibles hasta los 24 años de edad inclusive. (Artículo 66025.9 del Código de Educación)

Nivel 2: las citas de matrícula para los estudiantes en los grupos del Nivel 2 se programarán en todo el nivel con base en las unidades que han obtenido y el promedio de calificaciones acumuladas, de conformidad con la normativa aplicable.

Estudiantes del Programa de Excelencia Académica (Scholars' Honors Students): los estudiantes que han sido admitidos oficialmente en el Programa de Excelencia Académica cada semestre y en la actualidad se matriculan en los cursos o contratos del Programa de Excelencia Académica (Scholars' Honors Program).

Estudiantes Atletas: los estudiantes que se identifican como elegibles para participar en deportes intercolegiales.

Estudiantes con Requisitos de Inscripción Obligatoria: los estudiantes en cumplimiento de los requisitos del programa que deben mantener la condición de tiempo completo con los requisitos de tiempo de finalización para permanecer en los programas universitarios de Cerritos que están en programas financiados con donaciones con necesidades prioritarias de inscripción.

Estudiantes matriculados: estudiantes que, antes de su primer semestre de inscripción, completaron la admisión, orientación, evaluación y los componentes de asesoramiento de matriculación.

Grupos de prueba, financiamiento u otros grupos especiales para el éxito estudiantil: los estudiantes en grupos identificados por medidas mejoradas o aceleradas para el éxito estudiantil donde se emplean las pruebas, financiamiento y otras medidas especiales a corto plazo.

Nivel 3: las citas de matrícula para los estudiantes en los grupos del Nivel 3 se programarán en el orden en que los grupos aparecen en la lista y con base en las unidades que han obtenido y el promedio de calificaciones acumuladas, de conformidad con la normativa aplicable.

Estudiantes de reingreso: estudiantes que se inscribieron en el año académico anterior o en el curso de verano. Los estudiantes que no asistan al curso de verano no perderán la continuidad de la condición de estudiante de reingreso. La definición incluye a los estudiantes que no tienen créditos, quienes se matriculan en condición de estudiante con crédito.

Estudiantes que se reinscriben: los estudiantes que han completado al menos una unidad de crédito en Cerritos College y regresan después de un período de no más de un semestre sin contar el curso de verano.

Nivel 4: las citas de matrícula para los estudiantes en los grupos del Nivel 4 se programarán en el orden en que los grupos aparecen en la lista y con base en las unidades que han obtenido y el promedio de calificaciones acumuladas con esos grupos, de conformidad con la normativa aplicable.

Inscripción doble: estudiantes de penúltimo y último año de la escuela secundaria, según lo previsto y limitado en la Política del Consejo 5010 titulada Admisiones e inscripción simultánea y el Procedimiento Administrativo 5011 titulado Admisión e inscripción simultánea de la escuela secundaria y otros jóvenes estudiantes.

Inscripción doble (grado K-10): estudiantes de primaria y secundaria de la escuela secundaria hasta 10o grado, según lo previsto y limitado en la Política del Consejo 5010 titulada Admisiones e inscripción simultánea y el Procedimiento Administrativo 5011 titulado Admisión e inscripción simultánea de la escuela secundaria y otros jóvenes estudiantes.

LIMITACIONES DE INSCRIPCIÓN

La inscripción en los cursos y programas se puede limitar a los estudiantes que cumplen los requisitos previos y los requisitos conjuntos establecidos. (Consulte la Política del Consejo y el Procedimiento Administrativo 4260 titulado Requisitos previos y requisitos conjuntos)

Limitaciones de inscripción adicionales (incluyen, entre otros):

- A. consideraciones de salud y seguridad;
- B. carga de trabajo de los profesores;
- C. disponibilidad de instructores calificados;
- D. limitaciones de financiamiento;
- E. planificación regional;
- F. requisitos legales;
- G. limitaciones de instalaciones, y

Prioridades cuando la inscripción debe limitarse

- A. Por orden de llegada u otras técnicas de selección no evaluativas, siempre que se hayan cumplido todos los requisitos previos o los requisitos del curso.
- B. En el caso de las competencias intercolegiales, cursos de nivel avanzado o cursos de representación pública, se asignan los lugares disponibles a aquellos estudiantes que se consideren más calificados.
- C. Limitar la inscripción a cualquier procedimiento de selección que los estatutos autoricen expresamente.
- D. Limitar la inscripción en una o más secciones para los estudiantes inscritos en uno o más cursos, siempre que un porcentaje razonable de todas las secciones del curso no tengan tales restricciones.

Condiciones adicionales pueden ser aplicables al orden de inscripción

Secciones de los cursos financiados por distribución que no es del estado como la educación por contrato para los empleados de una compañía, los programas financiados con donaciones, y ciertas secciones de paga (según lo permite la ley).

PÉRDIDA DE ELEGIBILIDAD PARA RECIBIR LA EXENCIÓN DE CUOTAS DE INSCRIPCIÓN DE LA PROMESA DE BECA DE COLEGIO DE LA CALIFORNIA (CALIFORNIA COLLEGE PROMISE GRANT, CCPG)

Un estudiante ya no será elegible para recibir la Exención de cuotas de inscripción de la Promesa de Beca de Colegio de la California (California College Promise Grant, CCPG) si al estudiante se le pone en un período de prueba académico o de progreso, o en alguna combinación de estos, durante dos períodos académicos primarios consecutivos. La pérdida de elegibilidad entrará en vigencia en la primera oportunidad de inscripción después de que se haya tomado dicha determinación.

El distrito deberá notificar a los estudiantes sobre su asignación en el período de prueba académico o de progreso a más tardar treinta días después del final del período académico que provocó que al estudiante se le pusiera en un período de prueba. La notificación debe indicar claramente que dos períodos académicos primarios consecutivos en período de prueba ocasionarán la pérdida de la Exención de cuotas de inscripción de la CCPG hasta que el estudiante ya no esté en el período de prueba. La notificación también debe informar a los estudiantes acerca de los servicios de apoyo para estudiantes disponibles para ayudarlos a conservar la elegibilidad.

El distrito adoptará, exhibirá claramente y divulgará políticas que garanticen que los estudiantes estén informados acerca de los servicios de apoyo para estudiantes disponibles para ayudarlos a conservar y restablecer la elegibilidad para calificar para recibir la Exención de cuotas de inscripción de la CCPG. La divulgación incluye, entre otras, información proporcionada en los catálogos de la universidad y en los programas de clases.

El distrito establecerá procedimientos por escrito mediante los cuales un estudiante pueda apelar la pérdida de la Exención de cuotas de inscripción de la CCPG debido a circunstancias atenuantes, o cuando un estudiante con discapacidad solicite, pero no reciba, una adaptación razonable de manera oportuna. Las circunstancias atenuantes son casos verificados de accidentes, enfermedades u otras circunstancias que podrían incluir cambios documentados en la situación económica del estudiante, o bien, evidencia de que el estudiante no pudo obtener

servicios de apoyo esenciales para estudiantes. Las circunstancias atenuantes también incluyen la consideración especial de factores específicos relacionados con el estado del estudiante con respecto a la ayuda para Veteranos, el programa de California de Oportunidades de trabajo y responsabilidad hacia los niños (California Work Opportunity and Responsibility to Kids, CalWORKs), Programa de Oportunidad educativa (Educational Opportunity Program, EOP) y Programas y Servicios para estudiantes discapacitados (Disabled Students Programs & Services, DSPS).

Un joven en régimen de acogida familiar no estará sujeto a la pérdida de la Exención de cuotas de inscripción de la CCPG debido a la asignación en un período de prueba académico o de progreso. Esta exclusión para los Jóvenes en régimen de acogida familiar es válida hasta la fecha que se especifica en la sección 66025.9(c) del Código de Educación.

APELACIONES Y EXENCIONES

La intención de estos procedimientos es apoyar y promover el éxito del estudiante, incluyendo la finalización del programa, a través del acceso a los cursos necesarios. Las peticiones de apelación o para la exención de la aplicación de estos procedimientos están sujetas a consideración del Comité de Expedientes y Normas Académicas, o a quien este designe.

- A. Los estudiantes pueden apelar la pérdida de la prioridad de inscripción y/o la pérdida de la Exención de cuotas de inscripción de la CCPG debido a circunstancias atenuantes, ciertas condiciones especificadas en el Formulario de Inscripción de Prioridades y/o la Exención de cuotas de inscripción de la CCPG de Apelaciones, o cuando un estudiante con una discapacidad solicitada, pero que no recibió los ajustes razonables en el momento oportuno. Las circunstancias atenuantes verifican los casos de accidentes, enfermedades u otras circunstancias fuera del control del estudiante.
- B. Los estudiantes que han demostrado una mejora académica significativa restablecerán el estado la Exención de cuotas de inscripción de la CCPG y/o de prioridad de inscripción que perdieron. Es responsabilidad del estudiante verificar oportunamente los cambios del estado de las inscripciones de prioridad. El mejoramiento académico significativo se define como haber logrado por lo menos el promedio de calificaciones mínimo y las normas de progreso mínimas durante el semestre. El nivel académico mínimo es una calificación promedio mínima de 2.0, una vez que el estudiante haya intentado tomar 12 unidades semestrales; el progreso mínimo convencional es superior al 50% de todas las unidades en las que se inscribió que no reciban “W”, “I”, “NP”, o “NC”, una vez que el estudiante se haya matriculado en un total de al menos 12 unidades semestrales.
- C. Los estudiantes pueden solicitar el reintegro de la prioridad de inscripción y/o la Exención de cuotas de inscripción de la CCPG si se cometió un error institucional.

ADMISION

¿Quién puede solicitar admisión?

- Cualquier persona que sea graduada de secundaria o por lo menos de 18 años de edad.
- Estudiantes en su penúltimo año o con una forma aprobada de inscripción doble (Dual Enrollment).
- Estudiantes internacionales con visas validas F-1 de no inmigrante.

Como solicitar admisión

- Estudiantes que se matriculan por primera vez o que regresan después de una ausencia de uno o más semestres, deben completar una solicitud de admisión tan pronto como sea posible antes de el comienzo de inscripción. (Prueba de residencia podría ser necesaria). La solicitud de admisión se encuentra disponible en el sitio web de Cerritos College, www.cerritos.edu, "Future Students/Apply", "Apply Online".
- Estudiantes internacionales con visa F-1 de estudiante.
Estudiantes internacionales deben presentar una solicitud internacional de estudiante, reunir los requisitos de admisión específicos, y pagar una cuota de \$50 por el cobro de procesamiento.

ORIENTACIÓN

SRT/Colocación y Orientación-Consejería son requerimientos para todos los estudiantes nuevos o nuevos para el colegio. Es recomendable que también los estudiantes que se han transferido de otros colegios completen la orientación.

SRT/Colocación y Orientación-Consejería (AOC)

SRT/Colocación y Orientación-Consejería (AOC, por sus siglas en inglés) se necesita para los estudiantes de primer ingreso, nuevos en la universidad. Aparecerán dos retenciones en la cuenta MyCerritos de estos estudiantes: una retención por evaluación (ASM) y una retención por asesoría de orientación (ORI). *No se permitirá la inscripción en clases hasta que se haya cumplido con este requerimiento.* Los estudiantes a los que no se les solicite que completen los criterios establecidos quedan exentos automáticamente al momento de presentar la solicitud a la Universidad.

Programa de Éxito Prematuro (Early Success Program, ESP)

El Colegio de Cerritos ofrece el Programa de Éxito Prematuro durante el otoño y el semestre de primavera. Éste programa está diseñado para motivar a los estudiantes a completar con anticipación la Evaluación y Orientación-Consejería. Si completan la Evaluación y Orientación-Consejería antes de el plazo indicado, los estudiantes nuevos para el colegio reciben una cita más temprana para inscribirse. Para obtener más información, visite la página web www.cerritos.edu/esp.

Opciones de Orientaciones para Nuevos Estudiantes

En línea

Comience, pare, y vuelva a comenzar en cualquier momento! Vaya a www.cerritos.edu, entre al sistema de *MyCerritos*, y elija *Orientation Plus*.

En el plantel

Hay orientaciones disponibles antes de el comienzo de cada semestre, incluyendo de día y de noche. Llame a Oficina de Consejería al (562) 467-5231, ó en línea en el sitio www.cerritos.edu/aoc, para más información.

¿QUE ES "EL PROCESO DE COLOCACIÓN?"

El Colocación es obligatoria para los estudiantes de primer ingreso, nuevos en la universidad. "Colocación" significa el proceso de recopilar información sobre cada estudiante para facilitar su éxito. En Cerritos College el proceso incluyen, pero no se limitan a la recopilación de información relacionada con las técnicas de estudio del estudiante, dominio del inglés o aptitudes de computación. Los orientadores académicos revisarán el expediente académico de la escuela secundaria o universidad, evidencia del título A.A. u otro superior de una institución acreditada, habilidades de aprendizaje, rendimiento académico y uso de servicios especiales.

¿DEBO COMPLETAR EL PROCESO DE SRT/ COLOCACIÓN?

A partir de otoño de 2019, todos los estudiantes tendrán la oportunidad de colocarse en cursos de nivelación de inglés y matemáticas. Usando los expedientes de high school o la autocolocación dirigida, los estudiantes nuevos o regulares identificarán los cursos de inglés/inglés como segundo idioma (English as a Second Language, ESL) y matemáticas en los que pueden inscribirse.

Los estudiantes de primer ingreso, nuevos en el college, deben completar el proceso de colocación antes de la inscripción. Invitamos a los estudiantes regulares a quienes se les asignó un curso de matemáticas por debajo de matemáticas 80 o inglés 100 a completar este nuevo proceso de colocación.

Dependiendo de cuándo, dónde o si los estudiantes fueron a high school, completarán la herramienta de autoevaluación (Self-Report Tool, SRT) o la herramienta de colocación dirigida (Guided Placement Tool, GPT) que, en la mayoría de los casos, pondrá a los estudiantes directamente en los cursos de nivelación en las áreas de matemáticas e inglés o ESL. Para completar la SRT o GPT se necesita una identificación con fotografía y el número vigente de estudiante de Cerritos College.

¿Cómo completa la SRT o GPT? Visite el centro de evaluación en MP 206 o en línea en www.cerritos.edu/assessment-center/ para comenzar.

Recomendamos a los estudiantes con historia de educación especial a que busquen orientación para la asignación de más cursos con los consejeros en Programas y Servicios para Estudiantes con Discapacidades (Disabled Student Programs and Services). Visite www.cerritos.edu/dsps/ para obtener más información.

EXENCIÓN/EXCEPCIÓN DEL PROGRAMA DE ÉXITO Y APOYO PARA LOS ESTUDIANTES (STUDENT SUCCESS/SUPPORT PROGRAM, SSSP)

Cerritos Community College ofrece Servicios de Éxito y Apoyo para los Estudiantes a todos los estudiantes nuevos antes de inscribirse en las clases. Estos servicios incluyen colocación, orientación y asesoramiento. Los estudiantes de primer ingreso, nuevos en la Universidad deben completar la evaluación y colocación-orientación (SRT/Placement and Orientation-Counseling) obligatoria antes de inscribirse. Los estudiantes que no deben completar con los criterios establecidos están exentos automáticamente al momento de presentar la solicitud de ingreso a la universidad. Los estudiantes que deseen otro tipo de exención deben presentar un formulario de Exención al Programa de Éxito y Apoyo para los Estudiantes (SSSP) y el formulario de excepción a la Oficina de Admisiones y Expedientes. Los formularios de Exención y Excepción de SSSP están disponibles en las Oficinas de Admisiones y Expedientes, Evaluación y Asesoramiento. Si usted tiene necesidades especiales para completar el colocación, orientación o asesoramiento, comuníquese con la Oficina de Evaluación o Programas y Servicios para Estudiantes Discapitados.

EXENCIONES DE SRT/COLOCACIÓN

Los estudiantes que ya tienen un título de A.A. o superior de una universidad regional acreditada, no deben completar el proceso de colocación, pero deben verificar su título al presentar documentos oficiales ante la Oficina de Admisiones y Expedientes por lo menos 10 días hábiles antes de la fecha de su cita de inscripción. Debe adjuntar un formulario de Acreditación requerida con los documentos para cumplir con todos los requisitos.

EXENCIONES DE EVALUACIÓN/COLOCACIÓN PARA:

Inglés: es posible que los estudiantes que han completado cursos de inglés en otras universidades no tengan que completar la SRT de inglés. Presente pruebas (certificaciones oficiales o no oficiales) y el formulario de Acreditación requerida a un orientador o en Admisiones y expedientes antes de inscribirse.

Matemáticas: es posible que los estudiantes que han completado cursos de Matemáticas en otras universidades no tengan que completar la SRT de matemáticas. Presente pruebas (certificaciones oficiales o no oficiales) y el formulario de Acreditación requerida a un orientador o en Admisiones y expedientes antes de inscribirse. Se recomienda que estos cursos de Matemáticas se hayan completado en los últimos 10 años.

Exámenes avanzados de ubicación: los estudiantes que asisten a cursos de ubicación avanzados en sus escuelas secundarias y que obtengan promedios para aprobar los exámenes de AP pueden obtener créditos universitarios para dichos cursos cuando asistan a Cerritos College. Para obtener más detalles pregunte a un orientador.

Química: lea la sección de prerrequisitos y recomendaciones con cada listado de clases de química. Asegúrese de cumplir con todos los prerrequisitos antes de inscribirse en un curso.

Tenga en cuenta: Las excepciones indicadas son opciones de evaluación para las acreditaciones o ubicación de cursos. Para cumplir con los niveles de destreza requeridos de Lectura, Matemáticas, Inglés para calificar para el título en Artes de nivel intermedio, revise su catálogo o pregunte a un orientador.

UBICACIÓN PARA INGLÉS COMO SEGUNDO IDIOMA

Es posible que los estudiantes que desean tomar cursos de inglés como segundo idioma (ESL) deban someterse a una prueba ACCUPLACER ESL. Al completar la SRT, los estudiantes recibirán una recomendación para tomar la prueba ACCUPLACER ESL cuando sea apropiado. Es posible que los estudiantes aún deban someterse a la prueba ACCUPLACER ESL si consideran que pueden beneficiarse de la instrucción de ESL. Si tiene preguntas relacionadas con el mejor curso de instrucción, reúnase con un orientador.

POLÍTICA DE REPETICIÓN DE PRUEBAS

Los estudiantes que han completado la prueba ACCUPLACER y desean repetirla, ahora deben completar la Herramienta de auto evaluación (SRT). Los estudiantes que completaron sus estudios de escuela secundaria en los últimos 10 años recibirán recomendaciones de cursos con base en sus expedientes de la escuela secundaria de Estados Unidos. Con base en el promedio de notas acumuladas y ponderadas de la escuela secundaria de Estados Unidos y en otras preguntas académicas, los estudiantes se pueden ubicar directamente en los cursos de nivel de transferencia en las áreas de Inglés, Lectura, Matemáticas o ESL. Para completar la SRT computarizada necesita una identificación con fotografía y el número vigente de estudiante de Cerritos College. Los estudiantes que completaron sus estudios de la escuela secundaria hace más de 10 años antes de solicitar su ingreso a la universidad, que completaron GED o no terminaron la escuela secundaria o, si es estudiante internacional, deben comunicarse con la Oficina de Evaluaciones para obtener información relacionada con su situación específica.

PROGRAMA DE EVALUACIONES

Hay copias del programa de evaluaciones disponibles en la página web de la Oficina de Evaluaciones de Cerritos College, www.cerritos.edu/assessment-center; en la Oficina de Admisiones y expedientes. Servicios de orientación y carreras o llame al (562) 860-2451, ext. 2599 para ver

las fechas y los horarios. Las citas están disponibles durante el período de mayor demanda de pruebas entre julio y agosto. Para ver el programa vigente, consulte la página web ya que el programa está sujeto a cambios.

ADAPTACIONES PARA ESTUDIANTES CON DISCAPACIDADES

Cualquier estudiante con una discapacidad comprobada puede gestionar adaptaciones para la evaluación. Debe tener una solicitud vigente registrada en Cerritos College para recibir las adaptaciones. Las solicitudes de adaptaciones se deben hacer con por lo menos 7 días hábiles de anticipación a Programas y Servicios para Estudiantes Discapacitados (Disabled Students Programs and Services, DSPS). Para obtener más información o programar una cita, llame al (562) 860-2451, ext. 2335; (562) 274-7164 (VP); o visite nuestro sitio web en www.cerritos.edu/dsps. La administración alternativa puede incluir lectores, escritores o el uso de tecnología de asistencia.

CONSEJERIA

- Antes de inscribirse, todos los estudiantes nuevos en el college deben completar una orientación para estudiantes de primer ingreso para recibir ayuda del consejero en la elección de los cursos. Vea la sección "Orientation" (orientación) para obtener más información sobre la colocación y la orientación-asesoría. También recomendamos a los estudiantes de reingreso o transferidos que vayan con el consejero.
- Los consejeros tienen citas disponibles en persona o en línea, o en lista de espera/sin cita previa.
- Los estudiantes pueden enviar preguntas generales a un consejero en línea en www.cerritos.edu/counseling.
- Planifique: la orientación con citas programadas y en lista de espera/sin cita previa podría estar limitada durante los períodos de registro con mayor actividad.
- Una vez que empiece el semestre, recomendamos a los estudiantes nuevos, de reingreso y transferidos que hagan una cita para recibir orientación o que asistan a un taller de planificación educativa para hablar sobre sus objetivos educativos y hacer un plan educativo integral del estudiante (Comprehensive Student Educational Plan, C-SEP).
- Recomendamos a los estudiantes regulares que se reúnan con un consejero cada semestre para asegurarse de que su plan educativo refleje de manera precisa su objetivo educativo. Haga una cita o inscríbese para el taller de planificación educativa en la recepción de Counseling (orientación) o llame al (562) 467-5231.
- A los estudiantes que están en período de prueba de su progreso o en período de prueba académica se les limitará la cantidad de unidades que pueden tomar cada semestre con base en su Promedio de Calificaciones (Grade Point Average, GPA) y cursos completados. También se arriesgan a perder su cita de prioridad de inscripción y, a partir de otoño del 2016, es posible que ya no sean elegibles para recibir el beneficio de California College Promise Grant Fee Waiver, CCPGFW, si continúan en período de prueba durante dos semestres consecutivos.

SEGUIMIENTO

Consejería y profesores proporcionan una serie de servicios de seguimiento a los estudiantes. Estos servicios están diseñados para proporcionar información con respecto al progreso académico de los estudiantes. Se prestan servicios especiales a estudiantes que están en académico y/o progreso condicional, alumnus en cursos de habilidades básicas, y a los estudiantes que se encuentran indecisos sobre su meta educativa. Cuando es necesario los estudiantes son referidos a servicios fuera de esta institución.

ENROLLMENT INSTRUCTIONS

MYCERRITOS ENROLLMENT DATES

October 21, 2019 - March 27, 2020

Monday - Saturday
Sunday

2:00 am - midnight
8:00 am - midnight

*Enrollment in late start classes continue through the day of the week prior to the start date.

ENROLLMENT APPOINTMENTS

- All eligible continuing students have the opportunity to enroll for classes on or after their scheduled appointment date and time. Refer also to the "Student Success and Support Program" section on page 4 for information on enrollment priority, loss of priority, and appeal information.
- Appointment information can be reviewed in your "Student Center".
- To get to the **Student Center**, please log into the Cerritos College web page at www.cerritos.edu.
- Select "**MyCerritos**" and log on by entering your User ID (your 7-digit student ID number). If your student ID number is 6 digits, please add a zero to the front of the numbers.
- Enter your password, which is your 6-digit date of birth (mmddyy) **unless** you have changed it. Please note that Cerritos College does not have access to passwords that have been changed.
- Once you have logged into **MyCerritos**, select **Student Center**.
- Your scheduled appointment date and time will appear in the yellow box under "**Enrollment Dates**" to the right of the page.

WHO MAY ENROLL USING MYCERRITOS

All continuing students (students who attended Fall 2019), new, returning, and transfer students who have met Student Success and Support Program requirements.

Exceptions:

- First-time students who have an Assessment/SRT (ASM) or Orientation (ORI) hold.
- Students who have a Dismissal (DIS) hold.
- Students who have a "PRB" and/or "100+" hold due to second semester probation or more than 100 units.
- Students who have a Loss of CCPG Fee Waiver (LBW) hold.
- Students with enrollment holds (NSF checks, library and athletic obligations, administrative holds, etc.)

Information regarding probation and 100+ unit holds may be found on page 4 under "Priority Enrollment Criteria and Conditions".

RECOMMENDATIONS BEFORE ENROLLMENT

Academic Advisement:

Students who need advisement assistance are encouraged to see a counselor prior to their MyCerritos enrollment appointment date.

Clear Holds:

All enrollment holds must be cleared prior to your enrollment date.

CalWORKs, DSPS, EOPS, Foster Youth, and Student Veterans:

Should first contact a counselor or specialist in their program for enrollment assistance.

PLAN YOUR CLASS SCHEDULE

- Check student data on enrollment appointment.** If there are corrections, please contact the Admissions and Records Office, in person, as soon as possible. Address, phone number, and email corrections can be made by using **MyCerritos, Student Center**.
- Check "Holds" and "To Do List" prior to enrolling on MyCerritos, Student Center.**
- List classes in priority order; 18 units maximum per semester.**
- List alternative classes** in case your class choices are not available. Pick alternatives with the same time offerings.
- Verify your placement scores and completion of prerequisites.** Identify required **LABS** and possible **CLASS TIME CONFLICTS**.
- Students can make PROGRAM CHANGES (class adds and drops) by MyCerritos after initial enrollment.**

WAIT LIST NOTES

- Cerritos College uses an "auto-enroll" process from wait list to roster. You are responsible for all drops.** If you do not want your wait-listed classes, please drop to avoid a substandard grade and forfeiture of enrollment fees. For more information on wait lists, see "Wait List" on page 17.
- Prerequisites ARE CHECKED WHEN YOU ARE PLACED ON A WAIT LIST.** They are also checked at enrollment. YOU MAY LOSE A SEAT if prerequisites are not met when the instructor adds you to a class, or "auto-enroll" is activated. "Auto-enroll" will automatically enroll students from the wait list to the official roster when space becomes available.
- If you are enrolled in a class AND are on a wait list for the same course (i.e., enrolled in SOC 101 and #1 on the wait list for SOC 101 at another time), you will lose a seat when "auto-enroll" tries to move you from the wait list to the official roster due to "Multiple Enrollment".**

TO ENROLL

Verify your appointment date and time. If you log on to **MyCerritos** **before** your appointment date and time, the system will not allow you to enroll. However, you may log on anytime on or after your scheduled appointment date and time during published enrollment hours.

- Go to **MyCerritos** (<http://my.cerritos.edu>) or the Cerritos College home page and select **MyCerritos**.
- Enter your User ID (7-digit student ID number) and Password (6-digit date of birth).
- Select "**Student Center**".
- Select "**Enroll**".
- Verify Term (Spring 2020).
- Enter Class Number and select "**Next**".
- Verify class information and availability, and select "**Next**". If your class is closed you may wish to be added to a wait list, if available. Check the "**Wait List**" box and select "**Next**".
- Your class is now in your "**Shopping Cart**". You may enter another class number or, if done, select "**Proceed to Step 2 of 3**".
- Confirm your class(es) and select "**Finish Enrolling**".
- Verify your status as "**Success**".
- To pay for your class(es), select "**Make a Payment**" and follow the directions for credit card payments.

PLEASE NOTE: Students wishing to take a short-term class that is a prerequisite to the subsequent short-term class may enroll **IN PERSON** for class.

Example:

1st 9 weeks

English 52

2nd 9 weeks

English 100

The student may enroll in English 52 on their scheduled appointment date via MyCerritos AND THEN enroll in English 100, on or after their scheduled appointment date, **IN PERSON** in the Admissions and Records Office.

PAYING YOUR FEES

IMPORTANT: Students are required to pay all fees at the time of enrollment. Payment plans are not available. Each enrollment in a class, or add to a wait list for a class, results in a fee amount due. Students adding their names to wait lists will be charged the applicable enrollment fees, tuition, and applicable lab/materials fees. The amounts due will appear on the student account. **PAY CLOSE ATTENTION TO ALL DEBTS LISTED FOR EACH TRANSACTION.** The California College Promise Grant (CCPG) waives students' course enrollment fees; **however, all other fees, including but not limited to the Student Health fee, Student Activity fee, and applicable lab/materials fees, are due and payable at the time of enrollment.** (See FEES on page 19 for waiver information.)

Enrollment Period	Payment Schedule	Failure to Pay on Time
October 21, 2019 – January 10, 2020	In Person: Monday-Thursday, 8 am-6:30 pm Friday, 8 am-1:30 pm Online: Monday-Saturday, 2 am-midnight Sunday, 8 am-midnight	May result in a drop from classes and/or wait lists
Friday, January 10, 2020	In Person: Monday – Thursday, 8 am – 6:30 pm Friday, 8 am – 1:30 pm Online: No later than 11 pm	May result in a drop from classes and/or wait lists
January 11, 2020 – Instructor Add Period	Midnight of the following day	HOLD on all student accounts and records

ON THE WEB VIA MYCERRITOS ([HTTP://MY.CERRITOS.EDU](http://my.cerritos.edu)):

- After logging in, select “Student Center” on the MyCerritos home page.
- Under "Finances", select “Make a Payment”.
- Fees must be paid by credit card (MasterCard, VISA, Discover or American Express).

BY MAIL:

- MyCerritos will indicate your total fees and the date your payment is due.
- Enclose a money order or cashier’s check, or complete the credit card information on your registration payment coupon. **Cerritos College does not accept personal checks.** Please make your payment in the exact amount due and print your Student I.D. number in the “memo” portion of your money order or cashier’s check.
- Send your payment to: Admissions and Records, Cerritos College, 11110 Alondra Boulevard, Norwalk, CA 90650

ON CAMPUS:

- Pay your fees on campus in the Admissions and Records Office. Fee windows are open 8 am – 6:30 pm, Monday through Thursday; and 8 am – 2 pm, Friday. **Cerritos College does not accept personal checks.**
- You will receive an enrollment print-out and receipt.

If you require further assistance, contact the Admissions and Records Office at (562) 860-2451, extension 2211, 8 am–7 pm, Monday through Thursday; 8 am–2 pm, Friday.

BECOME A LEADER – JOIN STUDENT GOVERNMENT

WWW.CERRITOS.EDU/ACTIVITIES



WAIT LIST

As you enroll in classes, you may find that some are “closed.” This means that these classes have reached maximum enrollment. In this event you may choose to add your name to the wait list. The number of additions to wait lists is limited to 10 units. Please follow the instructions in **MyCerritos, Student Center**.

Cerritos College has implemented a “paid” wait list. What this means is that once you have added your name to the wait list, you must pay all applicable fees for that class. Additionally, “auto-enroll” will be in operation. Auto-enroll will automatically enroll students from the wait list to the official roster when space becomes available. Auto-enroll from a wait list will not occur if:

1. Student has a hold (service indicator) on their account. Please check in **MyCerritos, Student Center**, under **Holds and To Do List**.
2. The class prerequisite has not been met.
3. Illegal course repetition has occurred (See the Admissions and Records web page for Academic Records and Standards petition).
4. There is a class time conflict. Students may not be enrolled in two classes that meet at the same time.
5. If you are enrolled in a class AND are on a wait list for the same course (i.e., enrolled in SOC 101 and #1 on the wait list for SOC 101 at another time) you will lose a seat when “auto-enroll” tries to move you from the wait list to the official roster due to “Multiple Enrollment”.

Auto-enrollment will continue through the Friday before classes begin. View your enrollment status on **MyCerritos** (<http://my.cerritos.edu>). Failure to attend class IS NOT an automatic drop or refund. If you do not want your wait-listed classes, please drop to avoid a substandard grade and forfeiture of enrollment fees.

Prompt attendance on the first day is recommended for all wait-listed students. Failure to attend will jeopardize your enrollment status.



Earn a Bachelor’s Degree in Business on the Cerritos College Campus

- Degrees for working adults
- Year-round enrollment
- All classes taught on campus



Learn more at www.cerritos.edu/northwood

READING THE CLASS SCHEDULE

Must satisfy requirements PRIOR to taking the course

Time class meets. Evening classes are designated in bold print

Class meets online

Class number needed for enrollment

Dates class meets

Classes meet both on campus and online- See definition below

Online course- See definition below

Instructor name

Building & room number

Days the class meets

Specific instructor not yet designated

Course number	4.0 UNITS	Course name	
ENGL 100	4.0 UNITS	FRESHMAN COMPOSITION	
Transferable to UC, CSU (CAN ENGL 2)			
Prerequisite: Satisfactory completion of the English Placement Process or ENGL 52 or equivalent with a grade of Pass or "C" or higher.			
20372	11:00- 1:00PM	MW	STAFF
20375	2:00- 4:00PM	MW	Clemens,S
20376	3:00- 5:00PM	TTh	Ernest,R (HYBRID)
20880	5:00- 7:00PM	MW	O'Neil,S
21681	4.0 HRS ARR	(OL)	Swanson,J
Mandatory Orientation: 7:00 - 9:00 am, Saturday - January 14 in PS20.			
22149	7:00- 9:00AM	TTh	Mueller,B
22082	7:00- 9:40PM	TTh	STAFF
Class#22082 meets 01/30/2012-05/18/2012			
23244	8:00-12:00PM	MW	Conley,A
Class#23244 meets 01/09/2012-03/09/2012			
23065	1:00- 5:00PM	TTh	STAFF
Class#23065 meets 03/12/2012-05/18/2012			
			CB101
			CB102
			LC213
			LC134
			ONLINE
			LC134
			CB103
			CB106
			CB102

Online – Most work and communications occur online. Access to email and the internet is required.

Hybrid – Hybrid courses meet both on campus and online. See your instructor's website for class meetings.



FEES/REFUND INFORMATION AND PROCEDURES

FEES

1. ***Enrollment Fee:** \$46 per unit.
2. **Non-Resident Tuition:** Students who are non-residents of California or International Students, with or without F-1 visas, will be assessed \$285 per unit (\$265 per unit non-resident tuition and a \$20 per unit capital outlay fee) in addition to the \$46 per unit enrollment fee above.
3. **Student Activity Fee:** \$10 per semester; \$4 for summer session. This fee is automatically charged and is due and payable at enrollment, but may be waived subsequently by the student. Fee purpose and waiver information is available online at both the Admissions and Records' and the Office of Student Affairs' websites.
4. **Student Health Fee:** \$19 per semester; \$16 for summer session. Students who rely on prayer for healing and can supply the college with documentation from their spiritual leader are exempt.
5. **Parking:** On-campus student parking for vehicles is \$40 for our spring and fall semesters (\$30 for California College Promise Grant recipients) and \$25 for our summer semester. A daily parking permit can be purchased for \$2 from our permit dispensers located on the Marquee off Alondra, on Falcon Way, and in Lot 1, Lot 6, Lot 8, and Lot 10. In addition, Daily Permits can be purchased via [Park Mobile App](#). We also have timed parking with a 2 hour max which requires a timed parking permit that can be purchased from our permit dispensers located in Lot 2, Lot 6, and Lot 8.
6. **Lab/Materials Fees:** As listed with courses in this class schedule. Please note that failure to pay these fees may result in withdrawal from courses for lack of payment.

Students are required to pay all fees at the time of enrollment. Students adding their names to wait lists will be charged the applicable enrollment fees, tuition, and applicable lab/materials fees. Students who do not pay fees and drop classes after the refund date are still responsible for all fees. **California College Promise Grant Fee Waiver (CCPGFW) waives students' course enrollment fees; however, all other fees, including but not limited to the Student Health fee, Student Activity fee, and applicable lab/materials fees, are due and payable at the time of enrollment.** Payments for the parking, student activity, and student health fees may be subject to additional considerations.

A parking permit is required at all times to park a vehicle on our campus. The student activities fee is subject to student waiver. Information is available from the Office of Student Affairs located in the Student Activities Building. The Waiver Request form is available online at the Admissions and Records Forms web page. Revenue from the collection of this fee may be used by ASCC to support or oppose political measures. The student health fee may be waived with documentation from the student's spiritual leader that the student relies on prayer for healing.

*Subject to legislative change.

RESIDENT REQUIREMENTS

To be considered a California resident for purposes of admission to Cerritos College, a student is required to have resided in the state of California for at least one year and one day prior to the start of the semester for which the student is enrolling and present intent for one year and one day prior to the start of the semester for which the student is enrolling.

REFUND POLICIES AND PROCEDURES

It is the student's responsibility to apply for a refund. A student is eligible for a refund after classes have been officially dropped. Classes must be dropped

by the appropriate deadline for the session in order to be eligible for a refund. Stated deadlines are not adjusted due to late enrollment. Session dates and deadlines available for viewing online.

A student is eligible for a refund if: a) classes are dropped by the required deadline; b) the program change is the result of action taken by the college to cancel or reschedule a class; c) the student is dropped for failure to meet a prerequisite(s) or corequisite(s); and/or, d) the student is active or reserve U.S. Military personnel who withdraws due to military orders.

Eligible students may file a petition with the district requesting refund of their enrollment fee(s). A refund will not be processed if academic credit has been awarded for the class. Refunds are not automatically processed.

To request a refund, a student must come to the Admissions and Records Office and submit a Refund Request Form. The Refund Request Form is also available online and can be mailed to the Admissions and Records Office. Approved refunds will be mailed in approximately four to six weeks. Be sure your current mailing address is on file with the college.

A check is the only form of payment that Cerritos College uses to issue refunds. If a payment is made by credit card for any registration transaction, and you later drop any or all of your classes within the required refund period, we will **NOT** credit your credit card account. All refund checks are made payable to the student.

Refunds are made pursuant to Title 5, Section 58501 or 58501.1.

CREDITS/REFUNDS

Credits

Enrollment Fee, Non-Resident Tuition, and Capital Outlay Fee will be credited if the official drop has occurred within the appropriate deadline* for session or semester. This is in accordance with the Refund of Enrollment Fee Regulation, Title 5, 58508.

Student Health, Student Activity¹ and Parking Fees² will be credited only if all classes within the semester have been officially dropped within the appropriate deadline* for the semester.

* *Deadlines for fee credit are defined as the first two weeks of full semester length classes, or 10% of class meetings for shorter than semester-length classes.*

¹ *Student Activity sticker for the semester must be surrendered at the time of refund request. No refund will be given if sticker is marked or used.*

² *Parking Permit for the semester must be surrendered at the time of refund request.*

Refunds

A Refund Request Form must be completed to receive credit funds on the account. The Refund Request Form is available online on the Admissions web page under "FORMS", or in the Admissions and Records Office.

Time limit on requesting a refund: **A one-year limitation** exists on the credit. Students must apply for the refund between the beginning of the semester in which the credit was issued and the last day of the semester one year later. Example: Beginning of the Spring semester to the end of the Spring semester of the following year. Credit totals will be removed from the student account after this time.

**MYCERRITOS ACCEPTS PAYMENT BY MASTERCARD, VISA, DISCOVER OR AMERICAN EXPRESS CREDIT CARD.
This method of payment is encouraged for immediate confirmation of your enrollment.**

ACADEMIC INFORMATION

REPETITION OF COURSES

At Cerritos College, previous course enrollment is reviewed electronically for prior enrollment attempts. All courses have repetition limitations. Cerritos College offers some courses that have designated repeatability. Please review the catalog for maximum repeat units available.

Students may repeat a course in which a substandard grade (D, F, NP, FW) or “W” in any combination has been received one time. Students receiving any combination of substandard grades may petition the Academic Records and Standards Committee for an exception to the two attempts rule. All petitions are subject to approval or denial. Upon completion of a repeated course, the most recent grade earned will be computed in the cumulative grade point average and the student’s academic record so annotated.

When a student repeats a class to alleviate substandard academic work, the previous grade and credit shall be disregarded in the computation of grade point averages, but shall not be deleted from the student’s permanent record. Courses that are repeated shall be recorded on the student’s permanent academic record using an appropriate annotation. Annotating the permanent academic record shall be done in a manner so that all work remains legible, insuring a true and complete academic history.

Students may use an equivalent course from an accredited college or university to replace a Cerritos College course in which a substandard grade was recorded, if earned subsequent to the substandard grade at Cerritos College. The student must petition the Academic Records and Standards Committee to record the change. The College may honor the prior course repetition actions of other accredited colleges and universities in determining acceptance of credits, subject to student petition to, and approval by, the Academic Records and Standards Committee.

Examples of Exceptions for Consideration of Course Repetition Limitations

An Academic Records and Standards petition must be filed for official consideration of course repetition. All petitions are subject to approval or denial. Contact the Admissions and Records Office for specific directions.

1. Student received an “MW” (Military Withdrawal), or student received an “EW” (Extenuating Withdrawal).
2. Student’s previous grades are a result of documented extenuating circumstances beyond his/her control.
3. Cooperative work experience courses, subject to stated maximums, as provided in the College Administrative Procedures.
4. Certain activity or skill building courses, subject to stated maximums, as provided in College Administrative Procedures.
5. Certain classes for students with disabilities, subject to stated qualifications, as provided in College Administrative Procedures.
6. Repetition necessary for legally mandated training. Such courses may be repeated any number of times, regardless of whether or not substandard work was previously recorded, and the grade received each time shall be included for purposes of calculating the student’s grade point average.
7. After a significant lapse of time, a student may repeat a course in which a grade of “C” or better was received if the course is required by the district as a properly established recency prerequisite or another institution of higher education, to which the student is seeking to transfer, requires the student to have taken the course more recently than the student’s last enrollment (Title 5, Sections 55040(b)(3), 55053).

PASS/NO PASS CLASSES

Classes offered on a non-optional pass/no pass basis only will be indicated on a student’s permanent record as a “P” grade (with unit credit) or “NP” grade (no units earned). This will not affect the student’s grade point average. Optional pass/no pass courses are designed to encourage students to explore courses in areas they feel they may have an interest. See page 23 for guidelines and a list of approved courses in each department.

OPEN ENTRY/OPEN EXIT CLASSES

All students should meet with the instructor as soon as possible after the start of the session to inquire about enrollment (unless otherwise noted). A student may enter these classes at any time during the session prior to the specific cut-off date for the individual classes. The courses may be completed within the session in whatever time is necessary for the student to finish the course requirements.

DIRECTED STUDIES

Any student interested in pursuing independent projects on an individual basis for one or two units should contact a faculty member to determine if he/she is available to sponsor a directed studies project. Students may enroll in these classes only through the second week and with the authorization to enroll in Directed Studies Form, which must be signed by both the instructional dean and the faculty member conducting the Directed Studies.

WORK EXPERIENCE

Students may register for Cooperative Work Experience only through the second week of classes. Only a reduction of hours may be made after the first week.

PREREQUISITES, COREQUISITES, RECOMMENDATIONS AND PREREQUISITE CHALLENGE PROCEDURE

Please see “Prerequisites” in the Cerritos College Catalog.

DEFINITION OF A CLASS HOUR

A “class hour” is the basic unit of scheduled attendance and/or examination and is defined as a period not less than 50 minutes. A “clock hour” is a 60-minute time frame which is composed of one 50-minute class hour and a 10-minute segment referred to as a “passing period” or “break”. Classes scheduled for more than an hour follow formulas to stay within this definition. For example, a class scheduled from 8:00 to 8:50 has already incorporated the passing period and students must be in attendance for the full 50 minutes. Cerritos College has scheduled classes to account for the passing period and there is no need to leave 10 minutes early. Classes that meet for multiple hours may assign a 10-minute break between hours, but not in the last hour of attendance. Cerritos College follows these time patterns.

WITHDRAWALS [TITLE V, SECTION 58004 (C) (3)]

Pursuant to Title 5, section 58004 and Cerritos College Board Policy, it is the student’s responsibility to participate fully in class (es), once enrollment is complete. However, should it become necessary to withdraw from class, it is the student’s responsibility to drop in person in the Admissions and Records Office or through MyCerritos.

ACADEMIC INFORMATION

THE ULTIMATE RESPONSIBILITY OF WITHDRAWAL FALLS TO THE STUDENT.

How to officially withdraw after enrollment ends:

Complete an Add/Drop card (available in the Admissions and Records Office) or for a faster response, use MyCerritos (<http://my.cerritos.edu>). Retain an updated printout for your records.

ALL WITHDRAWALS MUST BE COMPLETED BY THE LISTED DEADLINES. FAILURE TO OFFICIALLY WITHDRAW FROM CLASS(ES) MAY RESULT IN AN “F/FW” GRADE FOR EACH CLASS. See the “Session Dates and Deadlines” now available online at: <https://www.cerritos.edu/admissions-and-records/add-drop-dates>.

WITHDRAWALS RESULTING IN PROGRESS PROBATION AND/OR GRADES RESULTING IN ACADEMIC PROBATION FOR TWO CONSECUTIVE TERMS CAUSE LOSS OF ENROLLMENT PRIORITY, WITH CERTAIN EXCEPTIONS, AND ARE SUBJECT TO APPEAL.

PROBATION

A. Academic Probation

Students who have attempted at least twelve (12) semester units as shown by the official academic record shall be placed on academic probation if the students have earned a grade point average below 2.0 in all units undertaken at Cerritos College.

B. Progress Probation

Students who have enrolled in a total of at least twelve (12) semester units as shown by the official academic record shall be placed on progress probation when the percentage of all units at Cerritos College which the students have attempted and for which entries of “W,” “I,” and “NP” are recorded reaches or exceeds 50 percent.

Probation is entered on the student’s permanent records and transcripts of record. Students placed on academic or progress probation will be notified by email at the email address listed on the official college record.

Probation Clearance:

A. Academic Probation Clearance

Students may clear academic probation by earning sufficient grade points to raise the cumulative grade point average to 2.0 or higher in the next semester of attendance. Probation status is not cleared by one semester of 2.0 GPA if it does not raise the cumulative GPA to 2.0 or higher.

B. Progress Probation Clearance

Students may clear progress probation by decreasing the percentage of “W,” “I,” or “NP” entries to less than 50 percent of all units in which the students have attempted.

Appeals:

Appeals of the loss of enrollment priority must be submitted on the Enrollment Priority Appeals Petition available on the Admissions and Records website. Automatic clearance is provided to students who achieve Significant Academic Improvement as defined in regulations.

STANDARDS FOR DISMISSAL

A. Academic Dismissal

Students are subject to academic dismissal when their GPA is less than 2.0 in 12 units or more for two consecutive semesters on academic probation. Students subject to academic dismissal shall be placed on continued probation when their latest semester’s GPA is 2.0 or higher.

B. Progress Dismissal

Students who have been placed on progress probation shall be

subject to dismissal if the percentage of units in which the students have been enrolled and for which entries of “W,” “I,” or “NP” are recorded in at least two (2) consecutive semesters reaches or exceeds 50 percent. Students subject to progress dismissal shall be placed on continued probation when no “W,” “I,” or “NP” entries are recorded for their latest semester.

Students are notified they have been placed on probation shortly after the beginning of the subsequent semester. Dismissal notices are issued before the start of the fall semester. Dismissed students may attend summer session to improve academic deficiencies.

REINSTATEMENT AFTER DISMISSAL

A. Academic Reinstatement

Students may re-enter the semester following academic dismissal through successful petition to the Academic Records and Standards Committee. However, such students will remain on probation until the accumulated GPA is 2.0 or higher.

B. Progress Reinstatement

Students may re-enter the semester following progress dismissal through successful petition to the Academic Records and Standards Committee. However, such students will remain on probation until the percentage of “W,” “I,” or “NP” entries is less than 50 percent of all units in which the students have enrolled.

Petitions must be filed prior to the deadline indicated on the readmission petition.

ADD/DROP PROCEDURES

If you wish to change your class schedule, please follow the steps below:

- Classes may be added via **MyCerritos, Student Center** (<http://my.cerritos.edu>).

To add a closed class, go to class on the first day and time that it meets; be on time. Respectfully request of the instructor(s) to be added to the class(es). If the instructor approves, an electronic enrollment will be submitted on your behalf to the Admissions and Records Office. Note that prerequisites, holds/service indicators (SI), conflicts, and illegal course repetition will be checked. Refer to the Fee Payment Schedule on page 16 for payment deadlines. Check your student account via **MyCerritos, Student Center** (<http://my.cerritos.edu>) or in the **Admissions and Records Office**. All enrollments must be completed by the listed add deadlines.

- Classes may be dropped via **MyCerritos, Student Center** (<http://my.cerritos.edu>). Be mindful of deadline dates for refunds and posting of “W’s” to transcripts.

LEVEL/SECTION CHANGES

Level/section changes must be processed in person. Program changes which involve level changes in skill and performance classes may be made by the add deadline. Students may also make level changes in Work Experience classes by the add deadline, but only a reduction of hours may be made after the add deadline.

Section changes may not be made between terms or semesters. A student may not drop a first 6/8-week course and then enroll in a second 6/8-week course by executing a section change. The student is required to officially drop the first 6/8-week class and then pay the appropriate fees to be enrolled in the second 6/8-week class. The money will not transfer from one term to another if the drop is processed outside of the refund date.

ACADEMIC INFORMATION

WHAT CERRITOS COLLEGE OFFERS

- Freshman and sophomore level course work transferable to four-year colleges and universities.
- Vocational/Technical courses designed to prepare for immediate employment.
- General education course work designed for academic, cultural, and educational enrichment.

DEADLINES

Throughout the enrollment process (including class petitioning), certain deadlines are necessary in order to comply with state attendance laws and must be followed by all students. Failure to comply with these guidelines may mean that the student will not be enrolled and will not receive credit for, or be allowed to, attend classes. Stated deadlines are not adjusted due to late enrollment.

RETURNED CHECK POLICY

Personal checks are not accepted for payment of tuition, fees, and other costs. If a check is accepted for another purpose, a \$25 fee will be charged on all returned and stop-payment checks. All fees are subject to change without notice in accordance with action taken by the Board of Trustees. Under state law, including California Civil Code 1719, any person who writes a check which is dishonored for lack of funds is civilly liable, and under the law is liable for at least \$100 or three times the amount of the check, plus additional costs.

FAILURE TO PAY FINANCIAL OBLIGATIONS

Failure to pay a financial obligation will result in an administrative withholding of grades, transcripts, diplomas or enrollment privileges, or any combination thereof. The item or items being withheld shall be released when the financial obligation has been met (California Code of Regulations, Title 5, Section 59410).

AUDITING OF COURSES

Auditing courses is permitted at Cerritos College. An auditor is a student who attends a course or courses for no credit or notation on an official transcript. Auditing may be available, pending signed permission, for any student who wishes to attend a course for information, review purposes, or skill building. Students wishing to audit should be aware that audited courses will NOT appear on the official transcript.

1. Students may not audit a course unless he/she has **exhausted all possibilities to take the course for credit**.
2. If criteria is met, permission to audit a course is granted at the discretion of the instructor. Signature of both the instructor and division dean are required.
3. With the instructor's and division dean's signed permission, a student may submit the audit form to the Admissions and Records Office anytime during the semester after the first class meeting.
4. An auditor may be allowed to elect credit in lieu of audit **prior** to the end of the **5th week** of school for a semester length course or **prior** to 30% of a course for a short-term course, **with the instructor's written permission**. No refund of audit fees will be available and all credit fees must be paid in full at the time of credit election.
5. A credit student may be allowed to elect audit status in lieu of credit **prior** to end of the **5th week** of school for a semester length course or **prior** to 30% of a course for a short-term course, **with the instructor's written permission**. No refund of credit fees will be available after the refund deadline and all audit fees must be paid in full at the time of audit election.
6. Credit students have priority over auditing students. If a course closes after an auditor has been admitted, the auditor may be asked to withdraw to make room for a credit student. Instructor discretion is strongly recommended.
7. The fee to audit a class is **\$15** per unit (in addition to the student fees). Students enrolled in 10 or more units can audit 3 units free (may be 3 one-unit classes). The **\$15** per unit audit fee will automatically be charged if the student drops below 10 units.

For additional information regarding auditing, students may make inquiries at the Counseling Office, Office of Academic Affairs, division office, or the Admissions and Records Office. Audit forms may be obtained in the Admissions and Records Office.

CREDIT BY EXAM CLASSES

Occasionally a student may feel that he/she can earn credit for a certain course by taking a special examination. The student may have gained proficiency through work experience, travel, or independent study. In these cases, a student may petition to receive unit credit by taking an exam prepared by the department. For more information, contact your counselor.

Credit by Examination will not be offered this semester by the Modern Languages Department.

The following courses have been designated by the divisions as those which may be taken for credit by examination:

BUSINESS, HUMANITIES, & SOCIAL SCIENCES

- Accounting 100
- Administration of Justice (all courses except for AJ 71, 91, 107, 173, 220)
- Business Administration 106, 107, 114, 115, 118, 120, 132, 156
- Business Communications Office Technology 131

FINE ARTS & COMMUNICATIONS

- Art 120
- Music 100, 101, 102, 103, 104, 104B, 105, 106, 110, 112, 120
- Photography 160
- Theatre 101, 102, 103, 110, 150, 151

HEALTH OCCUPATIONS

- Child Development/Early Childhood 161
- Culinary Arts 101
- Health Occupations 152
- Medical Assisting 63, 161
- Nursing (all courses)
- Pharmacy Technician 50, 83, 85

HPED/ATHLETICS

- Health Education 100

SCIENCE, ENGINEERING, & MATH

- Astronomy 102, 103
- Physics 100

TECHNOLOGY

- Autobody 51, 61, 181
- Automotive 100, 101, 109, 110, 120, 130, 140, 150, 160, 170, 180, 280
- Engineering Design Technology 103, 104, 105, 116, 117, 131, 133, 134, 138, 237, 257, 259, 260, 261, 262, 263
- Engineering Technology 101, 102, 103
- Machine Tool Technology 51, 59, 68, 71, 72, 180, 278
- New Product Development 100, 101, 102, 103, 104, 105, 106
- Plastics Manufacturing Technology 51, 53, 61, 67, 70, 72, 76, 100, 221

The option to enroll in a pass/no pass class is designed to encourage students



PASS/NO PASS CLASSES

to explore courses in areas they may feel they have an interest. Only these courses listed specifically for pass/no pass may be taken on this basis. Units thus earned may be counted toward the A.A. degree, but grade points are not assigned to pass/no pass grading symbols.

Courses approved for pass/no pass will be indicated on the student's permanent record as "P" with units earned and no grade points; or "NP" with no units earned and no grade points. Units attempted for which "NP" is recorded shall be considered in probation and dismissal procedures. The student is required to take all tests, complete all assignments, and shall be subject to all withdrawal and attendance regulations. Standards of evaluation are identical for all students. Please refer to the college catalog for additional information.

Non-Optional Pass/No Pass Classes

These classes are offered on a pass/no pass basis only and are graded entirely on a pass/no pass basis.

APPRENTICESHIP

Fire Sprinklers 72.01, 72.02, 72.03, 72.04, 72.05, 72.06, 72.07, 72.08, 72.09, 72.10, 72.11, 72.12, 72.13, 72.14, 72.15, 72.16, 72.17, 72.18, 72.19, 72.20, 72.21, 72.22, 72.23, 72.24, 72.25

BUSINESS, HUMANITIES, & SOCIAL SCIENCES

Law 1T

COUNSELING 10, 100, 101A, 101B, 101C

DISABLED STUDENT PROGRAMS & SERVICES

Access Learning 90, 91, 92

HEALTH OCCUPATIONS

Dental Assisting 1

Health Occupations 7

Nursing 5, 25, 26, 48T, 57LA, 57LB, 57LC, 57LD, 25I

Physical Therapist Assistant 126, 236, 246

HPED/ATHLETICS

Dance 50, 108C

LIBERAL ARTS

English 5L

English as a Second Language 36

Reading 6, 41

LIBRARY 50, 100, 101

SCIENCE, ENGINEERING, & MATH

Biology 95

Chemistry 95A, 95B, 95C, 95D, 95E, 95F

Math 5

Physics 95

TECHNOLOGY

Woodworking Manufacturing Technology 291

Optional Pass/No-Pass Classes: 15-unit limit

The student shall petition for an optional pass/no pass course through the Admissions and Records Office. The request for such a class must be completed no later than the end of the first 30% of the term. A student may be allowed to elect a letter grade in lieu of the pass/no pass option prior to completion of 30% of the course. See college catalog for additional information.

BUSINESS, HUMANITIES, & SOCIAL SCIENCES

(all business courses, except Business Administration 109, 116, 124, 125, 126, 208, 233; Law 65, 104, 105, 115, 150, 160, 171, 172, 290; Real Estate 98, 99, 101, 120, 125, 130, 151, 174A; or those listed under Non-Optional Pass/No Pass classes)

Administration of Justice 101, 102, 103, 113

Anthropology 170, 203

Economics 101, 204

History 120, 230, 245, 250, 255, 260, 265

Interdisciplinary Studies 100

Philosophy 100, 102, 103, 104, 106, 200, 298, 299

Political Science 90, 110, 210, 230

Sociology 110, 205, 220

Women's and Gender Studies 115, 140

COUNSELING 200, 210, 220, 298, 299

DISABLED STUDENT PROGRAMS & SERVICES

Access Learning 101

FINE ARTS & COMMUNICATIONS

Art 106, 110, 114, 116, 118, 120, 133A, 150, 155, 156L, 171, 182A, 191A, 191B, 193, 194A

Film 101, 103, 104, 159, 160, 293

Journalism 100, 101, 106, 107, 111, 119

Music 100, 101, 102, 103, 104, 104B, 112, 139, 143, 152, 153, 171, 244

Photography 100, 171

Theatre Arts 101, 107, 115, 120, 123, 123A, 126, 144, 150, 151, 171, 208, 216, 221, 221A, 222

HEALTH OCCUPATIONS

Health Occupations 150

Nursing 80

KINESIOLOGY

Athletics 202L, 240, 241, 242

Dance 100, 101, 102, 105, 106A, 106B, 107, 108A, 108B, 109, 110, 112, 120, 121, 122, 123, 124, 125, 126, 130A, 130B, 131, 132, 133, 134, 135, 136, 140, 141, 142, 143, 144, 150, 151

Health Education 100, 101, 110, 200, 201, 202

Kinesiology 110, 205, 206A, 206B

Physical Education (all activity courses)

LIBERAL ARTS

(all courses, except American Sign Language 110, 111, 210, 211, 220, English 225, 239, and 250, French 285, and Spanish 285, or those listed under Non-Optional Pass/No Pass classes)

SCIENCE, ENGINEERING, & MATH

Anatomy and Physiology 120, 150, 151, 200, 201

Biology 100, 105, 110, 115, 120, 200, 201, 202

Botany 120

Chemistry 100, 110, 111

Computer and Information Sciences (all courses, except CIS 160, 162, 164, 170A, 170B, 170E, 170F, 170G, 170H, 170I, 170K, 170L, 170P, 170R, 170S, 185, 200A, 207, 231, 286, 288, 292)

Earth Science 101, 102, 104, 104L, 106, 110

PASS/NO PASS CLASSES

Energy 100
Environmental Policy 200
Geography 101, 101L, 102, 103, 105, 140, 160
Geology 100, 101, 102, 102L, 103, 103L, 105L, 120, 201, 204, 207, 208, 209
Mathematics 20, 40, 60, 70, 75, 80, 80A, 80B, 105, 110A, 110B, 112, 114, 115, 116, 140, 170
Microbiology 200
Physical Science 100
Physics 100
Zoology 120

TECHNOLOGY

Architecture (all courses except for ARCH 101, 110, 112, 222)
Automotive Collision Repair 51, 52, 53, 54, 55, 56, 57, 58L, 59F, 59M, 59P, 59U, 61, 61L, 62, 63, 64, 65, 66, 67, 68L, 73, 74, 75, 76, 77, 79L, 80, 83A, 83P, 83U, 86, 88, 98, 99, 181, 182, 183, 188, 281, 282, 283, 285, 286, 287, 288
Automotive Mechanical Repair 5, 54, 55, 60, 73, 74, 80, 98, 99, 100, 109, 110, 111, 120, 121, 130, 140, 150, 151, 160, 161, 170, 179, 180, 181, 190, 193, 194, 195, 210, 211, 280, 281
Cosmetology 54, 55, 60A, 70A
Engineering Design Technology 102, 106, 137, 138, 139, 237, 267, 299
Machine Tool Technology 51, 52, 56, 57, 59, 62, 78, 91L, 92L, 94L, 95L, 100, 111, 112, 168
Manufacturing Technology 53, 54
Plastics/Composites Manufacturing Technology 53, 59, 61, 63L, 67, 68, 70, 72, 76, 98, 99, 100, 221
Welding 43, 44, 52, 53, 98, 99, 100, 120, 130, 200, 220, 240L, 250L
Woodworking Manufacturing Technology 1, 43, 44, 80, 98, 99, 100, 101, 102L, 120, 182L, 183, 211, 212, 222, 223, 224, 228L, 229L, 231, 232, 233, 235, 237, 239L, 246, 249L, 250, 252, 258, 269L, 281, 282



COURSE REPEATABILITY

Effective Fall 2013, repeatability in Dance, Drama, Physical Education, Visual Arts, and most Music courses has been changed. Intercollegiate Athletics and some Music and Theater courses that are required for transfer programs are the only courses in these disciplines that will remain repeatable; all other courses previously offered as repeatable will be offered as single enrollment courses. There will be a notation after the course description if the course is allowed to be repeated.

The college has developed Families of Courses. The Families of Courses include old and new courses related in content (see below for Families of Courses listed by department). A family of courses may consist of more than four courses, but students are limited to a maximum of four courses in any family. Further, all grades, including “W”s, will count toward the four-course enrollment limitation. Students can repeat Art, Dance, Drama, Music, and PE courses that are included in Families of Courses in which a grade of “NP”, “D”, or “F” was earned or a “W” was assigned; however, all enrollments count toward the four-enrollment maximum for each family of courses.

FAMILIES OF COURSES

ART AND DESIGN

3D Animation

Art 191A, 191B, 195

Calligraphy

Art 180, 181, 183A, 183B, 287A, 287B

Ceramics

Art 150, 151, 152, 153, 154, 252, 253

Computer Graphics

Art 184, 186, 189L, 284

Digital Painting

Art 196

Drawing

Art 111, 114, 183, 185, 285

Foundation Design Principles

Art 110, 120, 121

Graphic Design

Art 184, 284

Lettering and Typography

Art 182A, 182B

Life Drawing

Art 112, 213, 214, 232

Life Painting

Art 237, 238, 239

Motion Graphics

Art 198

Motion Picture Editing

Art 192, 192B

Multimedia Design

Art 194

Painting

Art 130A, 130B, 136, 231

Print Making

Art 116, 117, 218, 219

Water Coloring

Art 133A, 133B, 134, 135

COMMUNICATIONS STUDIES

Forensic Activity

Communications Studies 231, 232, 233

COUNSELING

Educational Planning

Counseling 101A, 101B, 101C

DANCE

Adaptive Dance

Dance 102

Ballet

Dance 106A, 106B, 107

Commercial Dance

Dance 110, 124, 126

Dance Composition

Dance 130, 130A, 130B

Dance Documentation

Dance 131, 132

Formal Dance Performance

Dance 133, 134, 136, 150

Informal Dance Performance

Dance 50, 135, 151

Introductory Dance

Dance 105

Modern Dance

Dance 108A, 108B, 108C

Partnering

Dance 120, 121, 125

Tap Dance

Dance 142, 143

Theatrical Dance

Dance 112, 140, 141, 144

World Dance

Dance 109, 122, 123

FILM

Motion Picture

Film 101, 104, 107, 293

Television

Film 102, 103

JOURNALISM

College Newspaper

Journalism 107, 107A, 107B, 107C, 107D

LIBRARY

Library Research

Library 100, 101

MUSIC

Guitar Studies

Music 120, 121, 122, 123

Piano

Music 112, 113, 115, 144

Vocal Studies

Music 116, 117, 118, 119, 143

PHYSICAL EDUCATION

Adapted Activities

PEX 100, 100A

Adapted Aquatics

PEX 105, 106, 106A

Adapted Fitness

PEX 101, 102, 104, 109

Adapted Individual Sports

PEX 108

Adapted Muscular Conditioning

PEX 103, 103A

Adapted Team Sports

PEX 107, 107A

Aerobics

PEX 110, 111, 112, 113

Badminton

PEX 161, 162, 261

COURSE REPEATABILITY

Baseball

PEX 163, 263

Basketball

PEX 165, 166, 265, 266

Bowling

PEX 167, 267

Cardiovascular Fitness

PEX 118, 119, 120, 121, 122, 132

Cheer

PEX 169, 170, 171, 271

Football

PEX 172, 272, 274

General Fitness

PEX 124, 126, 130

Golf

PEX 176, 276

Indoor Fitness

PEX 134, 135, 136

Muscular Conditioning

PEX 145, 245, 246

Pilates

PEX 155, 156, 157

Self Defense

PEX 147, 148, 149, 150, 249

Soccer

PEX 177, 178, 179, 278

Softball

PEX 181, 281, 282

Swimming

PEX 184, 185, 186, 284, 285

Tennis

PEX 188, 189, 288, 289

Volleyball

PEX 191, 192, 291, 292

Walking, Jogging and Running

PEX 138, 139, 140, 141, 142, 240

Water Aerobics

PEX 116, 117

Wrestling

PEX 194

Yoga

PEX 151, 152, 153

THEATER

Acting

Theatre 107, 110, 111, 212, 213, 216

Costuming

Theatre 144, 221, 221A

Crew

Theatre 109, 133, 134

Improvisation

Theatre 108, 117, 208

Make-Up

Theatre 123, 123A

Musical Theater

Theatre 105, 146, 147

Portable Entertainment

Theatre 223, 224, 225

Rehearsal and Performance

Theatre 130, 131, 132

Touring Theater

Theatre 136, 137



ATTENDANCE AND GRADING

ATTENDANCE

It is the responsibility of students to attend classes regularly and apply themselves to the college studies in which they are enrolled. When students have been absent due to illness, they should report to their instructor to explain the absence. **Students not in attendance or late for the first class meeting are subject to drop. Students who are absent in excess of 10% of the total class hours are subject to drop. Students who are absent during the course add period are subject to drop.** Certain academic and career technical education areas may have stricter attendance requirements. Listed below are two types of absences which permit the making up of work missed, provided that the work is of such a nature that it can be made up.

1. **AUTHORIZED ABSENCE:** For an approved educational field trip or school activity.
2. **EXCUSED ABSENCE:** For illness, injury, or quarantine.

NO CREDIT WILL BE GIVEN FOR A CLASS IN WHICH A STUDENT IS NOT OFFICIALLY ENROLLED. Students must attend the first class meeting or their names may be removed from the roll to allow another student seeking admission to enter. If a student is unable to attend the first class meeting, the instructor must be notified.

REMOVAL FROM CLASS

A student may be involuntarily removed from a course due to excessive absences, failure to meet prerequisite(s), or as a result of official disciplinary action (California Code of Regulations, Title 5, Section 55003).

GRADING

Accomplishment in course work is indicated by the following symbols:

Symbol	Definition	Grade Point
A	Excellent	4
B	Good	3
C	Satisfactory	2
D	Passing, less than satisfactory	1
F	Failing (earned)	0
FW	Failing, due to lack of participation and failure to withdrawal	0
I	Incomplete	-
P	Pass (at least satisfactory, the equivalent of a "C;" units awarded not counted in GPA)	-
NP	No Pass (less than satisfactory or failing; units not counted in GPA)	-
EW	Extenuating Withdrawl (without penalty)	-
MW	Military Withdrawal (without penalty)	-
W	Withdrawal	-
RD*	Report Delayed	-

* The RD symbol is used when there is a delay in reporting the grade of a student due to circumstances beyond the control of the student. It is a temporary notation to be replaced by a permanent symbol as soon as possible. RD shall not be used in calculating grade point averages.

INCOMPLETE

Students are not to re-enroll or audit a course in which a grade of "I" has been recorded. Incomplete academic work for unforeseeable, emergency, and justifiable reasons at the end of the term may result in an "I" symbol being entered in the student's record. The condition for removal of the "I" shall be stated by the instructor in a written record. This record shall contain the conditions for removal of the "I" and the grade assigned in lieu of its removal. This record must be given to the student with a copy on file with the Admissions and Records Office until the "I" is made up or the time limit has passed. A final grade shall be assigned when the work stipulated has been completed and evaluated, or when the time limit for completing the work has passed. The "I" may be made up no later than one year following the end of the term in which it was assigned. The "I" symbol shall not be used in calculating units attempted, nor for grade points. A student may petition for a time extension due to unusual circumstances by completing a petition form from the Admissions and Records Office.

GRADE CHANGES

The determination of the student's grade by the instructor shall be final in the absence of mistake, fraud, bad faith, or incompetency. The correction of a grade given shall only be allowed for a request initiated within one year following the end of the term in which it was assigned. Exceptions to the one-year limit on grade changes may be requested by petition of the student in extenuating circumstances. A formal petition must be submitted to the Academic Standards Committee. Extenuating circumstances are verified cases of accident, illness, or other circumstances beyond the control of the students (Title 5, Section 55760, Board Policy 4231).

GRADE REPORTS

To view your grades, log in to your MyCerritos account and select "Student Center", followed by "My Academics", and finally "Unofficial Transcript". Grades are not mailed to students.

FINANCIAL ASSISTANCE

FINANCIAL AID INFORMATION

The Financial Aid Office is available to answer financial aid questions and assist students with applying for financial aid.

Services:

- ◆ **Financial Aid Office Drop-Box** is available for submitting required documents.
- ◆ **Online Video Clips** about financial aid topics can be viewed at <https://cerritos.financialaidtv.com>.
- ◆ **Computer Stations and Staff** are available to assist with the following:
 - Submit a Free Application for Federal Student Aid (FAFSA)
 - Submit a California Dream Act Application
 - Check your To Do List in MyCerritos
 - IRS Data Retrieval
 - View disbursements via MyCerritos
 - Activate Cerritos Falcon Card
 - Apply for a loan
 - Accept/Decline loans
- ◆ **Workshops** are available for students with topics such as:
 - Financial Aid 101
 - Limits on Financial Aid
 - Paying for Transfer Education
 - California Dream Act Application
 - FAFSA Workshop
 - Financial Literacy

Contact Information:

Office Hours: Monday through Thursday
8 am to 7 pm
Friday
8 am to 2 pm

Website: www.cerritos.edu/finaid

Phone: (562) 860-2451, ext. 2397

E-mail: finaid-staff-list@cerritos.edu

Fax: (562) 467-5035



New! Online Check-in system. Save time, skip the line. Text “Cerritos College” to 562-375-4979 to join the line.

FINANCIAL AID PROCESS

Apply every academic year. Applications cover Fall, Spring, and Summer. Applications become available in October.

1 Apply

- Submit FAFSA at www.fafsa.gov or Dream Act Application at www.caldreamact.org
- List the federal school code for Cerritos College: 001161

2 Submit Forms

- View To Do List on MyCerritos
- Download required forms at www.cerritos.edu/fa-forms
- Submit required forms to the Financial Aid Office

3 Review Awards

- For award notification, check your message center on MyCerritos
- You must meet Satisfactory Academic Progress (SAP) standards to receive awards

4 Receive Disbursement

- Receive your Refund Selection Kit
- The Financial Aid Office will disburse your financial aid
- View account activity for refund status

IMPORTANT POINTS OF SATISFACTORY ACADEMIC PROGRESS (SAP)

To be eligible for federal and state financial aid funds (excluding the California College Promise Grant*), a student must make satisfactory academic progress. The Financial Aid Office at Cerritos College has established the following Satisfactory Academic Progress (SAP) standards to determine if a student is making satisfactory academic progress.

Grade Point Average (GPA) Requirement

You must maintain a 2.0 cumulative Grade Point Average (GPA).

Maximum Time Frame Requirement

Students must complete their educational program within a maximum time frame of 150% of the published program's required units at Cerritos College. For example, associate in arts degree and transfer programs generally require 60 units. Therefore, 150% of those programs would be 90 units (60 units x 1.5).

Unit Completion Requirement – Pace of Progress

Students are required to complete 67% of the units they have attempted. The cumulative units completed will be divided by the cumulative units attempted to calculate the pace of progress. All units are considered in his calculation. Units for which a grade of W, FW, NP, NC, and/or F was received are considered as units attempted, but not completed.

*Students must meet institutional academic and progress standards for the California College Promise Grant.

ADMISSION AND ENROLLMENT OF DUAL ENROLLED MINORS

Special Admit Minors are students enrolled in grades K-12 without high school diplomas, who can benefit from "advanced scholastic or career/technical work."

HIGH SCHOOL JUNIORS AND SENIORS

1. The high school principal or designee must recommend and give consent with signature on the Dual Enrollment Form that the student would benefit from college instruction.
2. A parent/guardian must approve student's participation and give consent by signing the Dual Enrollment Form. Signature of the parent/guardian also acknowledges that the student will conform to all College policies and procedures.

Academic Eligibility

- Students planning to enroll in degree appropriate courses must have a cumulative high school grade point average of 2.0 or higher shown on their most recent school transcript.
- For all courses attempted, students must complete the appropriate College assessment process and meet the stated prerequisite and/or co-requisite for the desired course.
- Students who require accommodations due to a disability should make arrangements through their K-12 school district, in consultation with the Disabled Student Programs and Services (DSPS) Office at Cerritos College. Please call (562) 860-2451, ext. 2335, for assistance.

Limitations on Enrollment

- A high school junior or senior student may be permitted to enroll in up to 8 units. Exceptions may be made, subject to consideration and approval by the Dean of Admissions, Records, and Services.
- Students may not enroll in pre-collegiate courses (1-99) or physical education courses.
- Students may not enroll in a College course to alleviate a high school deficiency.
- Students who have previously enrolled and who have dropped their courses and/or have not made satisfactory progress will not be allowed to continue in the Dual Enrollment Program.
- Students will not receive priority enrollment status and will be charged all applicable fees, with the exception of the California Community College in-state per unit enrollment fee.

ELEMENTARY AND SECONDARY STUDENTS THROUGH THE 10TH GRADE

1. The school principal or designee must recommend and give consent with signature on the Dual Enrollment Form that the student would benefit from college instruction.
2. A parent/guardian must approve student's participation and give consent by signing the Dual Enrollment Form. Signature of the parent/guardian also acknowledges that the student will conform to all College policies and procedures.

Cerritos College will admit highly gifted elementary students and secondary students through the 10th grade level for enrollment to the College if they are eligible to participate based on the following criteria:

Academic Eligibility

- Students must have a cumulative school grade point average of 2.5, or higher, as reflected on the most recent school transcript.
- For all courses attempted, the students must complete the appropriate College assessment process and meet the stated prerequisite and/or co-requisite for the desired course.
- Students who require accommodations due to a disability should make arrangements through their K-12 school district, in consultation with the Disabled Student Programs and Services (DSPS) Office at Cerritos College. Please call (562) 860-2451, ext. 2335, for assistance.

Limitations on Enrollment

- Students in grades K-10 may be permitted to enroll in up to 4 units. Exceptions may be made, subject to consideration and approval by the Dean of Admissions, Records, and Services. Enrollment in courses is based on space availability, and the College instructor's signature is required prior to enrollment.
- Students may not enroll in pre-collegiate courses (1-99) or physical education courses.
- Students may not enroll in a College course to alleviate a high school deficiency.
- Students who have previously enrolled and who have dropped their courses and/or have not made satisfactory progress will not be allowed to continue in the Dual Enrollment Program.
- Students will not receive priority enrollment status and will be charged all applicable fees, with the exception of the California Community College in-state per unit enrollment fee.

SUMMER ENROLLMENT OF K-12 STUDENTS

In addition to the above, minor students wishing to attend summer session must meet the additional criteria:

- The student demonstrates adequate preparation in the discipline to be studied.
- Pre-collegiate courses in English and mathematics may be taken if the student has exhausted all opportunities to enroll in an equivalent course at their school of attendance.

TO ATTEND CERRITOS COLLEGE AS A DUAL ENROLLMENT MINOR STUDENT, PLEASE FOLLOW THE STEPS BELOW:

1. Complete the Dual Enrollment Form and the Cerritos College Admission Application.
2. Review class(es) of choice, complete SRT(s) and pre-requisites.
3. Dual Enrollment Minors (K-10) must obtain the college instructor's signature prior to enrollment.

It is recommended that Dual Enrollment students (11-12 graders) meet with a Cerritos College academic counselor and participate in the New Student Orientation.

For more information, please call (562) 860-2451, ext. 2211.

OFFICE OF INTERNATIONAL STUDENT SERVICES



Cerritos College is a Student and Exchange Visitor Program (SEVP) certified and approved institution for nonimmigrant students.

The Office of International Student Services (OISS) welcomes international students to Cerritos College. Whether planning to achieve an Associate Degree and/or transfer to top universities, OISS is committed in assisting all students to reach their goal(s)! Visit the Office of International Student Services, located in the Santa Barbara Building, for the following services:

International Admission and Counseling Assistance: Assist F-1 international students with the admission process, academic advisement, orientation, registration, and cultural adjustment to the United States, Cerritos College, and our surrounding communities.

Intensive English Program (IEP): Cerritos College welcomes international students to develop English skills while introducing them to the American experience and to the diverse cultures of Southern California. Students completing Cerritos College IEP will have the opportunity to continue their education by transferring into the academic program for completion of an Associate of Arts degree and/or to transfer to a university.

Questions may be directed to the Office of International Student Services by phone at (562) 860-2451, ext. 2133, or by email at: oiss@cerritos.edu. Please visit our website at www.cerritos.edu/oiss for additional information or on Facebook at Cerritos College Office of International Student Services.

APPLICATION REQUIREMENTS

The following documents are required for admission to Cerritos College:

- International Student Admission Application (your name must appear the same as in your passport)
- A \$50 processing fee payable to Cerritos College
- Notarized Statement of Support (must be completed by a financial sponsor)
- Bank Certification (verification on bank letterhead, signed by a bank official, showing at least \$22,000, or equivalent, is available to the student). Personal checks will not be accepted for payment of tuition and fees.
- Tuberculosis (TB) exam results
- Transcripts (proof of high school graduation)/High School Diploma
- TOEFL, STEP, iTEP, and/or equivalent Cerritos College Placement Test (not required for students applying for the Intensive English Program)
- Copies of Passport, Visa, and I-94
- Copies of ALL I-20s (both SEVIS and Non-SEVIS I-20s)
- Transfer Authorization (if transferring from U.S. college or language school)
- Purchase of Medical Insurance: Cerritos College international students are required to purchase college-approved coverage from the Student Insurance Company - more information can be found on our website at <https://www.cerritos.edu/international/medical-insurance-requirement-1.htm>.
- Dependents: Attach a copy of the passport, marriage certificate, and/or birth certificate for each dependent. All dependents are required to have health insurance. Add \$3,000 per dependent to the Bank Certification.
- SEVIS I-20 fee of \$200 (preferred payment by credit card on the internet at www.fmjfee.com).

Note: We will assist students with other non-immigrant visa status (i.e., B-2, F-2, J-1, etc.) to change to F-1 student status.

International Student Advisement: Assist F-1 international students to stay in compliance with the United States Citizenship and Immigration Services (USCIS) and other U.S. and foreign governmental agencies while enrolled in full-time status at Cerritos College.

Workshops and Programs: Provide academic and immigration workshops as well as programs and activities to enhance student academic, personal, and cultural experiences.

Global Studies Club: A club run by students for students. We welcome all students to join for development of social and cultural skills, educational and professional experiences, and most importantly: to make friends from all around the world!

F-1 INTERNATIONAL STUDENT REQUIREMENTS

MAINTAINING F-1 INTERNATIONAL STUDENT REQUIREMENTS

- Enroll in a minimum of **12 units (full-time)** for the Fall and Spring semester
- Maintain a minimum 2.0 grade point average (C grade or better) each semester
- Limit enrollment in online classes to a maximum of 3 units as part of the 12-unit requirement
- Meet with the International Counselor each semester and as needed
- Meet with the International Counselor prior to dropping classes, changing class schedule, or concurrent enrollment at another school
- Enroll for classes on registration appointment date and pay fees by semester deadlines
- Will not work on or off-campus without authorization
- Purchase health insurance from the college approved carrier each academic year
- Notify the OISS of any changes and updates within 10 days on the following personal and college application information: name change, home address, email address, phone numbers, major and field of study, financial support, and dependents information.
- Meet with a Designated School Official (DSO) prior to traveling outside the U.S. and present I-20 and passport.
- File Internal Revenue Form 8843 annually. Download form at: www.irs.gov/Forms-&Pubs.
- File state and/or federal income tax if participating in APPROVED on or off-campus employment.
- **Falsification, Plagiarism, and Cheating** are violations of academic dishonesty and such actions are causes for termination of F-1 status and I-20 at Cerritos College.

Beginning May 29, 2015, F-2 children and/or the spouse of an F-1 student in the United States may study part-time in any certified program at an SEVP-certified school, so long as the study does not amount to what regulations define as full-time for F-1 students. For further assistance, please contact the Office of International Student Services at (562) 860-2451, ext. 2133, or via email at oiss@cerritos.edu.

Class#	Time	Day	Instructor	Room	Class#	Time	Day	Instructor	Room
--------	------	-----	------------	------	--------	------	-----	------------	------

ADMINISTRATION OF JUSTICE

AJ 91 - 3.0 UNITS REPORT WRITING PROCEDURES

Not Transferable
 Recommendation: An English Placement score into ENGL 100 or ENGL 52 with a grade of "C" or higher or "Pass" and satisfactory completion of the Reading Placement Process or READ 54 with a grade of "C" or higher or "Pass".

20184	9:30-10:45AM	MW	Jimenez,F	SS220
29687	5:00-6:15PM	TTh	STAFF	SS220

AJ 101 - 3.0 UNITS INTRODUCTION TO ADMINISTRATION OF JUSTICE

Transferable to UC, CSU (CAN AJ 2)
 Recommendation: An English Placement score into ENGL 100 or ENGL 52 with a grade of "C" or higher or "Pass" and satisfactory completion of the Reading Placement Process or READ 54 with a grade of "C" or higher or "Pass".

20185	8:00-9:15AM	MW	Gomez,R	SS212
20186	3.0 HRS ARR	(OL)	Jimenez,F	ONLINE
Note: Orientation is MANDATORY: 8:00 – 9:00 am, Friday – January 17 in SS 212.				
20787	5:00-6:15PM	TTh	STAFF	SS212
23331	6:30-9:20PM	W	STAFF	SS212
21592	9:30-10:45AM	MW	Jimenez,F	SS212
24166	8:00-10:50AM	F	STAFF	SS212

AJ 102 - 3.0 UNITS CONCEPTS OF CRIMINAL LAW

Transferable to UC, CSU (CAN AJ 4)
 Recommendation: An English Placement score into ENGL 100 or ENGL 52 with a grade of "C" or higher or "Pass" and satisfactory completion of the Reading Placement Process or READ 54 with a grade of "C" or higher or "Pass".

20187	6:30-9:20PM	M	STAFF	SS212
20188	8:00-9:15AM	TTh	Jimenez,F	SS212

AJ 103 - 3.0 UNITS CRIMINAL PROCEDURES

Transferable to CSU
 Recommendation: An English Placement score into ENGL 100 or ENGL 52 with a grade of "C" or higher or "Pass" and satisfactory completion of the Reading Placement Process or READ 54 with a grade of "C" or higher or "Pass".

20189	9:30-10:45AM	TTh	STAFF	SS212
23704	6:30-9:20PM	T	STAFF	SS220

AJ 104 - 3.0 UNITS CRIMINAL EVIDENCE

Transferable to CSU (CAN AJ 6)
 Recommendation: An English Placement score into ENGL 100 or ENGL 52 with a grade of "C" or higher or "Pass" and satisfactory completion of the Reading Placement Process or READ 54 with a grade of "C" or higher or "Pass".

20190	12:30-1:45PM	MW	STAFF	SS220
20790	8:00-9:15AM	MW	STAFF	SS220

AJ 105 - 3.0 UNITS COMMUNITY RELATIONS AND CULTURAL AWARENESS

Transferable to UC, CSU
 Recommendation: Completion of ENGL 52, ENGL 72 or ESL 152 or equivalent with a grade of "C" or higher, or "Pass," or completion of the English Placement Process with eligibility for ENGL 100 and completion of READ 54 or READ 97 with a grade of "C" or higher, or "Pass," or completion of the Reading Placement Process with eligibility for a course above the level or READ 54.

20191	3.0 HRS ARR	(OL)	STAFF	ONLINE
Note: Orientation is MANDATORY: 9:00 – 10:00 am, Friday – January 17 in SS 212.				
23332	11:00-12:15PM	TTh	STAFF	SS212

AJ 107 - 3.0 UNITS INTRODUCTION TO CORRECTIONS, PROBATION AND PAROLE

Transferable to CSU
 Recommendation: An English Placement score into ENGL 100 or ENGL 52 with a grade of "C" or higher or "Pass" and satisfactory completion of the Reading Placement Process or READ 54 with a grade of "C" or higher or "Pass".

21942	11:00-12:15PM	MW	Gomez,R	SS220
-------	---------------	----	---------	-------

AJ 110 - 3.0 UNITS PATROL PROCEDURES AND ENFORCEMENT TACTICS

Transferable to CSU
 Recommendation: An English Placement score into ENGL 100 or ENGL 52 with a grade of "C" or higher or "Pass" and satisfactory completion of the Reading Placement Process or READ 54 with a grade of "C" or higher or "Pass".

21542	11:00-12:15PM	TTh	STAFF	SS220
28576	6:30-9:20PM	T	STAFF	SS212

AJ 173 - 3.0 UNITS ADMINISTRATION OF JUSTICE OCCUPATIONAL WORK EXPERIENCE

Transferable to CSU
 Recommendation: An English Placement score into ENGL 100 or ENGL 52 with a grade of "C" or higher or "Pass" and satisfactory completion of the Reading Placement Process or READ 54 with a grade of "C" or higher or "Pass".

28135	12:30-1:20PM	T	Gomez,R	SS 16
-------	--------------	---	---------	-------

AJ 202 - 3.0 UNITS SUBSTANTIVE LAW

Transferable to CSU
 Prerequisite: AJ 102 or equivalent with a grade of "C" or higher or "Pass".
 Recommendation: An English Placement score into ENGL 100 or ENGL 52 with a grade of "C" or higher or "Pass" and satisfactory completion of the Reading Placement Process or READ 54 with a grade of "C" or higher or "Pass".

23333	8:00-9:15AM	TTh	Gomez,R	SS220
29983	6:30-9:20PM	M	STAFF	SS220

AJ 208 - 3.0 UNITS SPECIAL ISSUES IN LAW ENFORCEMENT

Transferable to CSU
 Recommendation: Completion of ENGL 52, ENGL 72, or ESL 152 or equivalent with a grade of "C" or higher, or "Pass," or completion of the English Placement Process with eligibility for ENGL 100 and completion of READ 54 or READ 97 with a grade of "C" or higher, or "Pass," or completion of the Reading Placement Process with eligibility for a course above the level of READ 54.

26391	6:30-9:20PM	Th	STAFF	SS220
--------------	--------------------	-----------	--------------	--------------

AJ 220 - 3.0 UNITS CRIMINAL INVESTIGATION

Transferable to CSU (CAN AJ 8)
 Recommendation: An English Placement score into ENGL 100 or ENGL 52 with a grade of "C" or higher or "Pass" and satisfactory completion of the Reading Placement Process or READ 54 with a grade of "C" or higher or "Pass".

20193	9:30-10:45AM	TTh	Gomez,R	SS220
20791	6:30-9:20PM	W	STAFF	SS220

AJ 221 - 3.0 UNITS NARCOTICS AND VICE CONTROL

Transferable to CSU
 Recommendation: An English Placement score into ENGL 100 or ENGL 52 with a grade of "C" or higher or "Pass" and satisfactory completion of the Reading Placement Process or READ 54 with a grade of "C" or higher or "Pass".

21543	6:30-9:20PM	Th	STAFF	SS212
--------------	--------------------	-----------	--------------	--------------

AJ 222 - 3.0 UNITS JUVENILE PROCEDURES

Transferable to CSU
 Recommendation: An English Placement score into ENGL 100 or ENGL 52 with a grade of "C" or higher or "Pass" and satisfactory completion of the Reading Placement Process or READ 54 with a grade of "C" or higher or "Pass".

28100	3.0 HRS ARR	(OL)	STAFF	ONLINE
Note: Orientation: 12:00 - 1:00pm, Friday - January 17 in SS 212.				
29689	11:00-12:15PM	MW	Jimenez,F	SS212

AMERICAN SIGN LANGUAGE

ASL 110 - 4.0 UNITS AMERICAN SIGN LANGUAGE I

Transferable to UC, CSU
 Recommendation: Completion of ENGL 52, ENGL 72 or ESL 152 or equivalent with a grade of "C" or higher, or "Pass," or completion of the English Placement Process with eligibility for ENGL 100 and completion of READ 54 or READ 97 with a grade of "C" or higher, or "Pass," or completion of the Reading Placement Process with eligibility for a course above the level or READ 54.

25207	9:00-10:50AM	MW	Kelly,E	LA209
			+ 1.0 HRS ARR	Kelly,E
LAB IS ONE HOUR PER WEEK IN THE SUCCESS CENTER				
25209	9:00-10:50AM	TTh	Kelly,E	LC209
			+ 1.0 HRS ARR	Kelly,E
LAB IS ONE HOUR PER WEEK IN THE SUCCESS CENTER				
27100	11:00-12:50PM	MW	Hall,C	LC213
			+ 1.0 HRS ARR	Hall,C
LAB IS ONE HOUR PER WEEK IN THE SUCCESS CENTER				
25213	9:00-10:50AM	TTh	Hall,C	LC213
			+ 1.0 HRS ARR	Hall,C
LAB IS ONE HOUR PER WEEK IN THE SUCCESS CENTER				
25769	9:00-10:50AM	MW	Hall,C	LC134
			+ 1.0 HRS ARR	Hall,C
LAB IS ONE HOUR PER WEEK IN THE SUCCESS CENTER				
25217	3:00-4:50PM	TTh	Harper-Johnson,P	LC213
			+ 1.0 HRS ARR	Harper-Johnson,P
LAB IS ONE HOUR PER WEEK IN THE SUCCESS CENTER				
26474	1:00-2:50PM	MW	Hall,C	LA209
			+ 1.0 HRS ARR	Hall,C
LAB IS ONE HOUR PER WEEK IN THE SUCCESS CENTER				
27102	3:00-4:50PM	MW	Morford,V	LA209
			+ 1.0 HRS ARR	STAFF
LAB IS ONE HOUR PER WEEK IN THE SUCCESS CENTER				
25225	5:00-6:50PM	TTh	Harper-Johnson,P	LA211
			+ 1.0 HRS ARR	STAFF
LAB IS ONE HOUR PER WEEK IN THE SUCCESS CENTER				
27251	5:00-6:50PM	MW	Morford,V	LA209
			+ 1.0 HRS ARR	Morford,V
LAB IS ONE HOUR PER WEEK IN THE SUCCESS CENTER				

Class#	Time	Day	Instructor	Room	Class#	Time	Day	Instructor	Room
ASL 111 - 4.0 UNITS AMERICAN SIGN LANGUAGE II					29637	8:00-10:50AM	T	Covill,M	S 129
Transferable to UC, CSU					29986	8:00-10:50AM	Th	Covill,M	S 129
Prerequisite: SL 101 or ASL 110 or equivalent with a grade of "C" or higher or "Pass".					29647	5:00-6:15PM	MW	STAFF	S 201
25227	11:00-12:50PM	MW	Kelly,E	LC209	29648	7:00-9:50PM	M	STAFF	S 129
	+ 1.0 HRS ARR		Kelly,E	LC205	29649	7:00-9:50PM	W	STAFF	S 129
LAB IS ONE HOUR PER WEEK IN THE SUCCESS CENTER					20173	8:00-10:50AM	M	STAFF	S 129
25229	7:00-8:50PM	TTh	Michelotti,A	LA212	29984	6:00-8:50PM	F	STAFF	S 129
	+ 1.0 HRS ARR		Michelotti,A	LC205		2:00-3:15PM	MW	STAFF	S 202
LAB IS ONE HOUR PER WEEK IN THE SUCCESS CENTER					A&P 151 - 4.0 UNITS INTRODUCTION TO HUMAN PHYSIOLOGY				
28171	5:00-6:50PM	TTh	Michelotti,A	LC213	Transferable to UC, CSU				
	+ 1.0 HRS ARR		Michelotti,A	LC205	Prerequisite: A&P 150 or equivalent with a grade of "C" or higher or "Pass".				
LAB IS ONE HOUR PER WEEK IN THE SUCCESS CENTER					Recommendation: CHEM 100 or equivalent with a grade of "C" or higher or "Pass".				
ASL 210 - 4.0 UNITS AMERICAN SIGN LANGUAGE III					20176	12:30-1:45PM	TTh	Lepere,S	S 103
Transferable to UC, CSU					20177	8:00-10:50AM	T	Lepere,S	S 127
Prerequisite: SL 102 or ASL 111 or equivalent with a grade of "C" or higher or "Pass".					29989	8:00-10:50AM	Th	STAFF	S 127
25231	3:00-4:50PM	TTh	Kelly,E	LA209	20780	5:30-6:45PM	MW	STAFF	S 103
	+ 1.0 HRS ARR		Kelly,E	LC205	20781	7:00-9:50PM	M	STAFF	S 127
LAB IS ONE HOUR PER WEEK IN THE SUCCESS CENTER					20782	7:00-9:50PM	W	STAFF	S 127
ASL 211 - 4.0 UNITS AMERICAN SIGN LANGUAGE IV					29638	12:30-1:45PM	MW	Tydell,C	S 103
Transferable to UC, CSU					29639	8:00-10:50AM	M	STAFF	S 127
Prerequisite: SL 201 or ASL 210 or equivalent with a grade of "C" or higher or "Pass."					29987	8:00-10:50AM	W	STAFF	S 127
26242	12:30-2:20PM	TTh	Hall,C	LA211	20178	2:30-5:20PM	T	Babiar,R	S 129
	+ 1.0 HRS ARR		Hall,C	LC205	29990	4:00-6:50PM	W	STAFF	S 127
LAB IS ONE HOUR PER WEEK IN THE SUCCESS CENTER						2:00-3:15PM	MW	STAFF	S 103
ASL 215 - 3.0 UNITS BEGINNING INTERPRETING AND ETHICS 1					A&P 201 - 5.0 UNITS HUMAN PHYSIOLOGY				
Transferable to CSU					Transferable to UC, CSU (CAN BIOL 12)(CAN BIOL SEQ B)				
Prerequisite: Completion of ASL 210 with a grade of "Pass" or "C" or higher or equivalent.					Prerequisite: A&P 200 and CHEM 100 or equivalents with grades of "C" or higher or "Pass."				
29002	11:00-1:50PM	TTh	Gough,T	LC213	20179	9:00-10:15AM	MW	Lepere,S	S 103
Class# 29002 meets 01/14/2020-03/12/2020						11:00-1:50PM	MW	Lepere,S	S 129
ASL 216 - 3.0 UNITS BEGINNING INTERPRETING AND ETHICS 2					ANTHROPOLOGY				
Transferable to CSU					ANTH 100 - 3.0 UNITS CULTURAL ANTHROPOLOGY				
Prerequisite: ASL 211 or ASL 215 or equivalent with a grade of "C" or higher or "Pass."					Transferable to UC, CSU (CAN ANTH 4)				
29877	11:00-1:50PM	TTh	Gough,T	LC213	Prerequisite: Satisfactory completion of English & Reading Placement Process or ENGL 52, ENGL 72, or ESL 152, or equivalent with a grade of "C" or higher or "Pass" and READ 54 or READ 97 or equivalent with a grade of "C" or higher or "Pass".				
Class# 29877 meets 03/24/2020-05/21/2020					20195	8:00-9:15AM	MW	Rigby,J	SS139
ASL 220 - 3.0 UNITS DEAF CULTURE					20196	2:00-3:15PM	TTh	Rigby,J	SS139
Transferable to UC, CSU					20197	8:00-9:15AM	TTh	Rigby,J	SS139
29878	12:30-1:50PM	TTh	Kelly,E	LA209	22615	12:30-1:45PM	TTh	Bellas,M	SS139
					24167	7:00-10:20PM	W	Abbruzzese,M	SS139
					Class# 24167 meets 02/04/2020-05/19/2020				
ANATOMY AND PHYSIOLOGY					ANTH 115 - 3.0 UNITS PHYSICAL ANTHROPOLOGY				
A&P 120 - 4.0 UNITS INTRODUCTION TO HUMAN ANATOMY AND PHYSIOLOGY					Transferable to UC, CSU (CAN ANTH 2)				
Transferable to UC, CSU					22357	6:30-7:45AM	MW	Rigby,J	SS315
Prerequisite: ENGL 52 or ENGL 72 or ESL 152 or equivalent with a grade of "C" or higher or "Pass," or completion of the English placement process with a score eligible for ENGL 100.					20198	9:30-10:45AM	MW	Rigby,J	SS315
20168	9:30-10:45AM	MW	Tydell,C	S 201	20200	12:30-1:45PM	TTh	Rigby,J	SS315
20169	11:30-2:20PM	T	STAFF	S 129	20201	7:00-9:50PM	T	Abbruzzese,M	SS315
20170	2:00-4:50PM	W	STAFF	S 129	20792	7:00-9:50PM	Th	Garcia,S	SS315
20171	12:30-3:20PM	Th	Tydell,C	S 129	21953	11:00-12:15PM	MW	Abbruzzese,M	SS315
23603	12:00-2:50PM	F	STAFF	S 129	23335	11:00-12:15PM	TTh	Vechayiem,D	SS315
20778	7:00-9:50PM	T	STAFF	S 129	23336	5:30-8:20PM	W	Bellas,M	SS315
20779	7:00-9:50PM	Th	STAFF	S 129	25682	5:00-6:15PM	TTh	Bellas,M	SS315
	5:30-6:45PM	TTh	STAFF	S 103	20199	2:00-3:30PM	MW	Abbruzzese,M	SS315
					Class# 20199 meets 02/03/2020-05/20/2020				
					26392	6.0 HRS ARR	(OL)	Bellas,M	ONLINE
					Note: Orientation will take place through class website.				
					Class# 26392 meets 01/13/2020-03/13/2020				
					29690	6.0 HRS ARR	(OL)	Bellas,M	ONLINE
					Note: Orientation will take place through class website.				
					Class# 29690 meets 03/23/2020-05/22/2020				
					ANTH 115L - 1.0 UNIT INTRODUCTION TO PHYSICAL ANTHROPOLOGY LAB				
					Transferable to UC, CSU				
					Prerequisite: ANTH 115 with a grade of "C" or higher or "Pass" or concurrent enrollment.				
20172	11:00-12:15PM	MW	Babiar,R	S 202	21943	12:30-3:20PM	T	Abbruzzese,M	SS220
20174	2:00-4:50PM	M	Babiar,R	S 129	22734	1:00-3:50PM	Th	Little,L	SS220
20175	9:00-11:50AM	F	Babiar,R	S 129	22384	11:00-1:50PM	F	Garcia,S	SS220
20204	8:00-10:50AM	W	Babiar,R	S 129					
25662	12:00-2:50PM	F	STAFF	S 103					
	3:00- 5:50PM	F	STAFF	S 129					
29635	12:30-1:45PM	TTh	Covill,M	S 202					
29636	3:30-6:20PM	Th	STAFF	S 129					

Students not in attendance or late for the first class meeting are subject to drop.

Class#	Time	Day	Instructor	Room	Class#	Time	Day	Instructor	Room
24168	2:00-4:50PM	F	Little,L	SS220					
26393	2:00-4:50PM	W	Vechayiem,D	SS220					
ANTH 120 - 3.0 UNITS INTRODUCTION TO ARCHAEOLOGY Transferable to UC, CSU (CAN ANTH 6) Prerequisite: ENGL 100 or equivalent with a grade of "C" or higher or "Pass." 23337 7:00-9:50PM M Abbruzzese,M SS139					ART 100 - 3.0 UNITS INTRODUCTION TO WORLD ART Transferable to UC, CSU Recommendation: ENGL 52, or ENGL 72 or ESL 152 and READ 54 or READ 97 or equivalent with grades of Pass or "C" or higher. 21778 3.0 HRS ARR (OL) Goldsmith,M ONLINE 21839 12:30-3:20PM M Goldsmith,M FA133				
ANTH 202 - 3.0 UNITS THE MAYA, INCA AND AZTECS: ANCIENT CIVILIZATIONS OF THE AMER Transferable to UC, CSU 28087 9:30-10:45AM TTh Rigby,J SS139					ART 101 - 3.0 UNITS ART HISTORY I: PREHISTORY TO GOTHIC Transferable to UC, CSU (CAN ART 2) Recommendation: ENGL 52, or ENGL 72 or ESL 152 and READ 54 or READ 97 or equivalent with grades of Pass or "C" or higher. 20205 3.6 HRS ARR (OL) Vitela,L ONLINE Class# 20205 meets 01/13/2020-05/01/2020 28787 8:00-10:50AM TTh Robertson,C TBA Class# 28787 meets 01/14/2020-03/12/2020				
ANTH 203 - 3.0 UNITS THE ANTHROPOLOGY OF MAGIC, WITCHCRAFT, AND RELIGION Transferable to UC, CSU Recommendation: Satisfactory completion of the English Placement Process or ENGL 52 or equivalent with a grade of "C" or higher or "Pass" and satisfactory completion of the Reading Placement Process or READ 54 with a grade of "C" or higher or "Pass". 21664 9:30-10:45AM TTh Little,L SS141					ART 102 - 3.0 UNITS ART HISTORY II: RENAISSANCE TO ROCOCO Transferable to UC, CSU (CAN ART 4) Recommendation: ENGL 52, or ENGL 72 or ESL 152 and READ 54 or READ 97 or equivalent with grades of Pass or "C" or higher. 22879 8:00-10:50AM M Vitela,L FA133 22878 3.6 HRS ARR (OL) Vitela,L ONLINE Class# 22878 meets 01/13/2020-05/01/2020				
ANTH 205 - 3.0 UNITS THE ANTHROPOLOGY OF SEXUALITY AND GENDER Transferable to UC, CSU Recommendation: Completion of ENGL 52, or ENGL 72, or ESL 152 or equivalent with a grade of "C" or higher, or "Pass," or completion of the English Placement Process with eligibility for ENGL 100 and satisfactory completion of READ 54 or READ 97 with a grade of "C" or higher, or "Pass," or completion of the Reading Placement Process with a score of "Reading Exempt." 23338 12:30-1:45PM MW Abbruzzese,M (Women's Studies) SS139					ART 105B - 3.0 UNITS THE ARTS OF LATIN AMERICA AND THE CARIBBEAN: COLONIAL TO THE PRESENT Transferable to UC, CSU Recommendation: ENGL 52, or ENGL 72 or ESL 152 and READ 54 or READ 97 or equivalent with grades of Pass or "C" or higher. 29714 8:00-10:50AM TTh Robertson,C FA134 Class# 29714 meets 03/24/2020-05/21/2020				

ARCHITECTURE

ARCH 110 - 3.0 UNITS INTRODUCTION TO ARCHITECTURE AND ENVIRONMENTAL DESIGN Transferable to UC, CSU 23513 4:30-5:50PM TTh Van,H PST230 Please read the technical standards relevant to this department at https://www.cerritos.edu/technology/standards.htm . 30114 3.0 HRS ARR (OL) Greas,M ONLINE				
ARCH 111 - 3.0 UNITS ARCHITECTURAL DRAFTING AND DESIGN I Transferable to CSU 23088 8:00-9:00AM TTh Rother,E PST230 9:00-10:50AM TTh Rother,E PST230				
ARCH 112 - 3.0 UNITS HISTORY OF ARCHITECTURE Transferable to UC, CSU 20203 9:00-11:50AM T Paul,D PST236 20794 12:30-3:20PM T Paul,D PST236 27188 3:00-5:50PM Th Phinney,P PST236 30001 3.0 HRS ARR (OL) Greas,M ONLINE				
ARCH 122 - 2.0 UNITS ARCHITECTURAL DELINEATION Transferable to UC, CSU 22741 12:30-1:00PM TTh Van,H PST230 1:00-2:20PM TTh Van,H PST230				
ARCH 123 - 4.0 UNITS INTRODUCTION TO 2D COMPUTER AIDED DRAFTING Transferable to CSU 27914 11:00-12:30PM MW Rother,E PST227 12:30-1:50PM MW Rother,E PST227				
ARCH 213 - 4.0 UNITS INTRODUCTION TO 3-D COMPUTER AIDED DRAFTING Transferable to CSU 29582 8:00-9:00AM MW Rother,E PST224 29583 9:00-10:50AM MW Rother,E PST224				
ARCH 223 - 4.0 UNITS REVIT ARCHITECTURE Transferable to CSU 29579 7:00-8:30PM MW Morales,T PST230 8:30-9:50PM MW Morales,T PST230				

ART AND DESIGN									
ART 100 - 3.0 UNITS INTRODUCTION TO WORLD ART Transferable to UC, CSU Recommendation: ENGL 52, or ENGL 72 or ESL 152 and READ 54 or READ 97 or equivalent with grades of Pass or "C" or higher. 21778 3.0 HRS ARR (OL) Goldsmith,M ONLINE 21839 12:30-3:20PM M Goldsmith,M FA133					ART 101 - 3.0 UNITS ART HISTORY I: PREHISTORY TO GOTHIC Transferable to UC, CSU (CAN ART 2) Recommendation: ENGL 52, or ENGL 72 or ESL 152 and READ 54 or READ 97 or equivalent with grades of Pass or "C" or higher. 20205 3.6 HRS ARR (OL) Vitela,L ONLINE Class# 20205 meets 01/13/2020-05/01/2020 28787 8:00-10:50AM TTh Robertson,C TBA Class# 28787 meets 01/14/2020-03/12/2020				
ART 102 - 3.0 UNITS ART HISTORY II: RENAISSANCE TO ROCOCO Transferable to UC, CSU (CAN ART 4) Recommendation: ENGL 52, or ENGL 72 or ESL 152 and READ 54 or READ 97 or equivalent with grades of Pass or "C" or higher. 22879 8:00-10:50AM M Vitela,L FA133 22878 3.6 HRS ARR (OL) Vitela,L ONLINE Class# 22878 meets 01/13/2020-05/01/2020					ART 105B - 3.0 UNITS THE ARTS OF LATIN AMERICA AND THE CARIBBEAN: COLONIAL TO THE PRESENT Transferable to UC, CSU Recommendation: ENGL 52, or ENGL 72 or ESL 152 and READ 54 or READ 97 or equivalent with grades of Pass or "C" or higher. 29714 8:00-10:50AM TTh Robertson,C FA134 Class# 29714 meets 03/24/2020-05/21/2020				
ART 107 - 3.0 UNITS ASIAN ART HISTORY Transferable to UC, CSU Recommendation: ENGL 52, or ENGL 72 or ESL 152 and READ 54 or READ 97 or equivalent with grades of Pass or "C" or higher. 28725 3.6 HRS ARR (OL) Vitela,L ONLINE Class# 28725 meets 01/13/2020-05/01/2020					ART 108 - 3.0 UNITS BLACK IMAGES IN POPULAR CULTURE Transferable to UC, CSU Recommendation: ENGL 52 and READ 54 or equivalent with grades of Pass or "C" or higher is strongly recommended. 28181 3:30-6:20PM TTh Trager,J (Honors Section) FA134 Class# 28181 meets 01/14/2020-03/12/2020				
ART 109 - 3.0 UNITS GENDER AND SEXUALITY IN ART Transferable to UC, CSU Recommendation: ENGL 52 and READ 54 or equivalent with grades of Pass or "C" or higher is strongly recommended. 29715 2:30-5:20PM MW Trager,J FA134 Class# 29715 meets 01/13/2020-03/11/2020					ART 110 - 3.0 UNITS FREEHAND DRAWING Transferable to UC, CSU (CAN ART 8)				
20208 8:00-9:00AM TTh Tran,B FA227 9:00-10:50AM TTh Tran,B FA227 20209 9:00-10:00AM MW Bersaglieri,A FA227 10:00-11:50AM MW Bersaglieri,A FA227 20210 1:00-2:00PM MW Teran,S FA231 2:00-3:50PM MW Teran,S FA231 25672 6:00-7:00PM TTh Rolon,A FA231 7:00-8:50PM TTh Rolon,A FA231 20211 1:00-2:00PM TTh Graziano,A FA227 2:00-3:50PM TTh Graziano,A FA227 25674 9:00-11:00AM F Minear,S FA231 11:00-2:50PM F Minear,S FA231 20795 6:00-7:00PM MW Kuo,A FA231 7:00-8:50PM MW Kuo,A FA231 27205 6:00-7:00PM MW Acuna,R FA227 7:00-9:20PM MW Acuna,R FA227 28033 9:00-11:00AM F Phelps,J FA227 11:00-2:50PM F Phelps,J FA227 28788 1:00-2:00PM MW Bersaglieri,A FA227 2:00-3:50PM MW Bersaglieri,A FA227									

Students not in attendance or late for the first class meeting are subject to drop.

Class#	Time	Day	Instructor	Room	Class#	Time	Day	Instructor	Room
ART 112 - 3.0 UNITS LIFE DRAWING Transferable to UC, CSU (CAN ART 24) Prerequisite: ART 110 or equivalent with a grade of "C" or higher or "Pass".					ART 136 - 3.0 UNITS PAINTING FOR ART MAJORS Transferable to UC, CSU Prerequisite: ART 110 or equivalent with a grade of "C" or higher or "Pass". Recommendation: ART 120 or equivalent with a grade of "C" or higher or "Pass".				
20212	9:00-10:00AM	MW	Najarian,H	FA207					
	10:00-11:50AM	MW	Najarian,H	FA207					
20796	1:00-2:00PM	MW	Graziano,A	FA207	27885	8:00-9:00AM	TTh	Graziano,A	FA207
	2:00-3:50PM	MW	Graziano,A	FA207		9:00-10:50AM	TTh	Graziano,A	FA207
21833	6:00-7:00PM	MW	Martinez,E	FA207	20221	1:00-2:00PM	TTh	Najarian,H	FA207
	7:00-8:50PM	MW	Martinez,E	FA207		2:00-3:50PM	TTh	Najarian,H	FA207
ART 114 - 3.0 UNITS STORYBOARDING AND ANIMATION PRINCIPLES FOR FILM Transferable to CSU					ART 150 - 3.0 UNITS INTRODUCTION TO CERAMICS Transferable to UC, CSU (CAN ART 6)				
20213	2:00-3:00PM	TTh	Hirohama,S	FA136	23307	9:30-10:30AM	MW	Robinson,D	FA140
	3:00-4:50PM	TTh	Hirohama,S	FA136		10:30-12:20PM	MW	Robinson,D	FA141
ART 115L - 1.0 UNIT PRINTMAKING LAB Transferable to UC, CSU Corequisite: Concurrent enrollment in ART 116 or ART 117					20222 12:30-1:30PM TTh STAFF FA140 1:30-3:20PM TTh STAFF FA141 20801 6:30-7:30PM TTh Gonzalez,A FA140 7:30-9:20PM TTh Gonzalez,A FA141				
20797	5:30-6:50PM	MW	Teran,S	FA153	ART 151 - 3.0 UNITS CERAMICS-BEGINNING WHEELTHROWING Transferable to CSU Prerequisite: ART 150 or equivalent with a grade of "C" or higher or "Pass".				
ART 116 - 3.0 UNITS BEGINNING PRINTMAKING Transferable to UC, CSU (CAN ART 20)					20223 4:00-5:00PM MW Weiss,T FA140 5:00-6:50PM MW Weiss,T FA141				
20798	7:00-8:00PM	MW	Teran,S	FA113	ART 152 - 3.0 UNITS CERAMICS-BEGINNING HANDBUILDING Transferable to CSU Prerequisite: ART 150 or equivalent with a grade of "C" or higher or "Pass".				
	8:00-9:50PM	MW	Teran,S	FA113	20224	4:00-5:00PM	MW	Weiss,T	FA140
ART 117 - 3.0 UNITS INTERMEDIATE PRINTMAKING Transferable to UC, CSU Prerequisite: ART 116 or equivalent with a grade of "C" or higher or "Pass".					5:00-6:50PM MW Weiss,T FA141				
20799	7:00-8:00PM	MW	Teran,S	FA113	ART 153 - 3.0 UNITS CERAMICS-INTERMEDIATE WHEELTHROWING Transferable to CSU Prerequisite: ART 151 or equivalent with a grade of "C" or higher or "Pass".				
	8:00-9:50PM	MW	Teran,S	FA153	20225	4:00-5:00PM	MW	Weiss,T	FA140
ART 120 - 3.0 UNITS TWO-DIMENSIONAL DESIGN Transferable to UC, CSU (CAN ART 14)					5:00-6:50PM MW Weiss,T FA141				
20214	12:30-1:30PM	TTh	Teran,S	FA113	ART 154 - 3.0 UNITS CERAMIC-INTERMEDIATE HANDBUILDING Transferable to CSU Prerequisite: ART 152 or equivalent with a grade of "C" or higher or "Pass".				
	1:30-3:20PM	TTh	Teran,S	FA113	20226	4:00-5:00PM	MW	Weiss,T	FA140
20800	6:00-7:00PM	TTh	Lopez,R	FA113		5:00-6:50PM MW Weiss,T FA141			
	7:00-8:50PM	TTh	Lopez,R	FA113	ART 156L - 1.0 UNIT CERAMICS LAB Transferable to CSU Corequisite: One or more of the following courses: ART 150, ART 151, ART 152, ART 155, ART 252, ART 253 or ART 255.				
ART 121 - 3.0 UNITS THREE-DIMENSIONAL DESIGN Transferable to UC, CSU (CAN ART 16) Prerequisite: ART 120 or equivalent with a grade of "C" or higher or "Pass".					22567 9:30-1:40PM F Cramer,J FA141 Class# 22567 meets 02/07/2020-05/22/2020				
20215	12:30-1:30PM	MW	Weiss,T	FA149	21144	4:00-6:15PM	TTh	Gonzalez,A	FA141
	1:30-3:20PM	MW	Weiss,T	FA149	Class# 21144 meets 02/04/2020-05/21/2020				
ART 122 - 3.0 UNITS COLOR THEORY Transferable to UC, CSU Prerequisite: Completion of Art 110 or Art 120 or equivalent with a grade of "C" or higher or Pass.					ART 182A - 3.0 UNITS LETTERING AND TYPOGRAPHY Transferable to CSU				
27879	1:00-2:00PM	MW	Najarian,H	FA113	20227	12:30-1:30PM	TTh	Gill,S	FA239
	2:00-3:50PM	MW	Najarian,H	FA113		1:30-3:20PM	TTh	Gill,S	FA239
ART 125 - 3.0 UNITS INTRODUCTION TO VISUAL AND CULTURAL STUDIES Transferable to CSU Recommendation: ENGL 52 or ENGL 72 or ESL 152 or equivalent with a grade of "C" or higher or Pass or completion of the English placement process with a score eligible for ENGL 100 and READ 54 or READ 97 or equivalent with a grade of "C" or higher or Pass or completion of the Reading placement process with a score of "Reading Exempt.					ART 184 - 3.0 UNITS GRAPHIC DESIGN I Transferable to CSU Prerequisite: ART 182A or equivalent with a grade of "C" or higher or "Pass".				
29717	12:30-3:20PM	Th	Trager,J	FA134	29057	9:00-11:00AM	F	Jankowski,J	FA239
Class# 29717 meets 01/16/2020-03/12/2020					11:30-3:20PM F Jankowski,J FA239				
ART 130A - 3.0 UNITS FUNDAMENTALS OF PAINTING Transferable to UC, CSU (CAN ART 10) Prerequisite: ART 110 or equivalent with a grade of "C" or higher or Pass. Recommendation: ART 120 or equivalent with a grade of "C" or higher or Pass.					ART 186 - 3.0 UNITS COMPUTER GRAPHICS WITH ADOBE ILLUSTRATOR Transferable to CSU				
27881	8:00-9:00AM	TTh	Graziano,A	FA207	20228	12:30-1:30PM	MW	Barrett,B	FA235
	9:00-10:50AM	TTh	Graziano,A	FA207		1:30-3:20PM	MW	Barrett,B	FA235
20217	1:00-2:00PM	TTh	Najarian,H	FA207	ART 188 - 3.0 UNITS DESIGN FOR DIGITAL PUBLISHING Transferable to CSU				
	2:00-3:50PM	TTh	Najarian,H	FA207	22523	8:00-9:00AM	MW	Barrett,B	FA235
ART 130B - 3.0 UNITS FUNDAMENTALS OF PAINTING Transferable to UC, CSU Prerequisite: ART 130A or equivalent with a grade of Pass of "C" or higher.					9:00-10:50AM MW Barrett,B FA235				
27883	8:00-9:00AM	TTh	Graziano,A	FA207	ART 191A - 3.0 UNITS 3D COMPUTER ANIMATION Transferable to CSU				
	9:00-10:50AM	TTh	Graziano,A	FA207	20230	4:00-5:10PM	TTh	Wilson,C	FA234
20219	1:00-2:00PM	TTh	Najarian,H	FA207		5:10-7:20PM TTh	Wilson,C	FA234	
	2:00-3:50PM	TTh	Najarian,H	FA207	Class# 20230 meets 01/14/2020-05/07/2020				

Students not in attendance or late for the first class meeting are subject to drop.

Class#	Time	Day	Instructor	Room	Class#	Time	Day	Instructor	Room
ART 191B - 3.0 UNITS 3D COMPUTER ANIMATION PROJECT					ART 217L - 1.0 UNIT ADVANCED SCREENPRINTING/ADVANCED ETCHING LAB				
Transferable to CSU					Transferable to CSU				
Prerequisite: ART 191A or equivalent with a grade of "C" or higher or "Pass".					Corequisite: Concurrent enrollment in ART 218 or ART 219.				
26985	4:00-5:10PM	TTh	Wilson,C	FA234	20805	5:30-6:50PM	MW	Teran,S	FA153
	5:10-7:20PM	TTh	Wilson,C	FA234					
Class# 26985 meets 01/14/2020-05/07/2020									
ART 192 - 3.0 UNITS PHOTOSHOP/DIGITAL IMAGING					ART 218 - 3.0 UNITS SCREENPRINTING				
Transferable to CSU					Transferable to UC, CSU				
Prerequisite: ART 117 or equivalent with a grade of Pass of "C" or higher.					Prerequisite: ART 117 or equivalent with a grade of Pass of "C" or higher.				
20232	12:30-1:30PM	MW	Miller,K	FA234	20806	7:00-8:00PM	MW	Teran,S	FA113
	1:30-3:20PM	MW	Miller,K	FA234		8:00-9:50PM	MW	Teran,S	FA153
20234	2.0 HRS ARR	(OL)	Wilson,C	ONLINE					
	+ 4.0 HRS ARR	(OL)	Wilson,C	ONLINE					
26987	2.0 HRS ARR	(OL)	Wilson,C	ONLINE	ART 219 - 3.0 UNITS ADVANCED ETCHING				
	+ 4.0 HRS ARR	(OL)	Wilson,C	ONLINE	Transferable to UC, CSU				
27887	12:30-1:30PM	TTh	Miller,K	FA235	Prerequisite: ART 117 or equivalent with a grade of Pass of "C" or higher.				
	1:30-3:20PM	TTh	Miller,K	FA235	20807	7:00-8:00PM	MW	Teran,S	FA113
						8:00-9:50PM	MW	Teran,S	FA153
ART 192B - 3.0 UNITS ADVANCED PHOTOSHOP					ART 231 - 3.0 UNITS INTERMEDIATE PAINTING				
Transferable to CSU					Transferable to UC, CSU				
27889	12:30-1:30PM	TTh	Miller,K	FA235	Prerequisite: ART 130B or equivalent with a grade of "C" or higher or "Pass".				
	1:30-3:20PM	TTh	Miller,K	FA235	27891	8:00-9:00AM	TTh	Graziano,A	FA207
21781	12:30-1:30PM	MW	Miller,K	FA234		9:00-10:50AM	TTh	Graziano,A	FA207
	1:30-3:20PM	MW	Miller,K	FA234	21629	1:00-2:00PM	TTh	Najarian,H	FA207
						2:00-3:50PM	TTh	Najarian,H	FA207
ART 193 - 3.0 UNITS MOTION PICTURE EDITING					ART 298 - 1.0 UNIT DIRECTED STUDIES				
Transferable to CSU					Transferable to CSU				
23574	12:30-1:40PM	TTh	Wilson,C	FA234	29188	3.0 HRS ARR		Graziano,A	FA228
	1:40-3:50PM	TTh	Wilson,C	FA234	29189	3.0 HRS ARR		Robinson,D	FA143
Class# 23574 meets 01/14/2020-05/07/2020					29215	3.6 HRS ARR		Gonzalez,A	FA143
					Class# 29215 meets 02/03/2020-05/22/2020				
ART 194A - 3.0 UNITS ADVANCED FINAL CUT PRO					ART 299 - 2.0 UNITS DIRECTED STUDIES				
Transferable to CSU					Transferable to CSU				
26339	12:30-1:40PM	TTh	Wilson,C	FA234	29190	6.0 HRS ARR		Graziano,A	FA228
	1:40-3:50PM	TTh	Wilson,C	FA234					
Class# 26339 meets 01/14/2020-05/07/2020									
ART 195 - 3.0 UNITS 3D MODELING FOR ANIMATION					ASTRONOMY				
Transferable to CSU					ASTR 102 - 3.0 UNITS INTRODUCTORY ASTRONOMY: STARS AND THE UNIVERSE				
26989	9:00-10:00AM	MW	Miller,K	FA234	Transferable to UC, CSU				
	10:00-11:50AM	MW	Miller,K	FA234	22915	4:00-5:15PM	TTh	Szabo,T	S 104
					23873	7:00-9:50PM	W	Szabo,T	S 104
ART 195B - 3.0 UNITS ADVANCED 3D MODELING					29675	12:30-1:45PM	MW	Szabo,T	S 104
Transferable to CSU					23662	9:00-12:30PM	F	McElroy,D	S 101
Prerequisite: Completion of ART 195 or equivalent with a grade of "C" or higher or "Pass."					Class# 23662 meets 02/07/2020-05/22/2020				
29083	9:00-10:00AM	MW	Miller,K	FA234	29673	8:00-10:50AM	TTh	Hugenberger, S	S 104
	10:00-11:50AM	MW	Miller,K	FA234	Class# 29673 meets 01/14/2020-03/12/2020				
ART 196 - 3.0 UNITS WEB DESIGN WITH FLASH AND DREAMWEAVER					ASTR 103 - 3.0 UNITS INTRODUCTORY ASTRONOMY: THE SOLAR SYSTEM				
Transferable to CSU					Transferable to UC, CSU				
Recommendation: CIS 205 or equivalent with a grade of "C" or higher or "Pass".					Orientation: All class information will be available online via Canvas.				
20236	8:00-9:00AM	TTh	Miller,K	FA235	22205	3.0 HRS ARR	(OL)	McLarty-Schroeder,J	ONLINE
	9:00-10:50AM	TTh	Miller,K	FA235	Email address jmclarty@cerritos.edu				
ART 198 - 3.0 UNITS MOTION GRAPHIC					22427	3.0 HRS ARR	(OL)	McLarty-Schroeder,J	ONLINE
Transferable to CSU					Orientation: All class information will be available online via Canvas.				
29063	9:00-11:00AM	F	Mazaheri Nazarifar,S	FA235	Email address jmclarty@cerritos.edu				
	11:30-3:20PM	F	Mazaheri Nazarifar,S	FA235	22601	3.0 HRS ARR	(OL)	McLarty-Schroeder,J	ONLINE
					Orientation: All class information will be available online via Canvas.				
ART 213 - 3.0 UNITS INTERMEDIATE LIFE DRAWING					26127	9:30-10:45AM	MW	McLarty-Schroeder,J	PST124
Transferable to UC, CSU					20243	8:00-10:50AM	TTh	Hugenberger, S	S 104
Prerequisite: ART 112 or equivalent with a grade of "C" or higher or "Pass".					Class# 20243 meets 03/24/2020-05/21/2020				
20237	9:00-10:00AM	MW	Najarian,H	FA207	ASTR 104 - 3.0 UNITS LIFE IN THE UNIVERSE				
	10:00-11:50AM	MW	Najarian,H	FA207	Transferable to UC, CSU				
20803	1:00-2:00PM	MW	Graziano,A	FA207	20809	9:30-10:45AM	TTh	McLarty-Schroeder,J	PST124
	2:00-3:50PM	MW	Graziano,A	FA207	ASTR 105L - 1.0 UNIT OBSERVATIONAL ASTRONOMY				
21930	6:00-7:00PM	MW	Martinez,E	FA207	Transferable to UC, CSU				
	7:00-8:50PM	MW	Martinez,E	FA207	Prerequisite: ASTR 101 or ASTR 102 or ASTR 103 or ASTR 104 or ASTR 106 or equivalent with a grade of "C" or higher or "Pass" or concurrent enrollment.				
ART 214 - 3.0 UNITS SPECIAL STUDIES IN LIFE DRAWING					20810	7:00-9:50PM	Th	Szabo,T	PST124
Transferable to UC, CSU					22916	7:00-9:50PM	T	Szabo,T	PST124
Prerequisite: ART 213 or equivalent with a grade of "C" or higher or "Pass".									
20238	6:00-7:00PM	MW	Graziano,A	FA207					
	7:00-8:50PM	MW	Martinez,E	FA207					
20804	9:00-10:00AM	MW	Najarian,H	FA207					
	10:00-11:50AM	MW	Najarian,H	FA207					
21928	1:00-2:00PM	MW	Graziano,A	FA207					
	2:00-3:50PM	MW	Graziano,A	FA207					

Students not in attendance or late for the first class meeting are subject to drop.

Class#	Time	Day	Instructor	Room	Class#	Time	Day	Instructor	Room
ASTR 106 - 3.0 UNITS HISTORY OF ASTRONOMY Transferable to UC, CSU 29674 3.0 HRS ARR (OL) Szabo,T ONLINE Orientation: All class information will be available online via Canvas. Email address tszabo@cerritos.edu.					ATH 228L - 3.0 UNITS TRACK AND FIELD, WOMEN Transferable to UC, CSU 25141 10.0 HRS ARR Richardson,C STADT				
ATH 200L - 3.0 UNITS BASEBALL, MEN Transferable to UC, CSU 25123 10.0 HRS ARR STAFF BASBL					ATH 231LB - 2.0 UNITS VOLLEYBALL, WOMEN, OFF SEASON INTERCOLLEGIATE Transferable to UC, CSU 27247 6.0 HRS ARR Hemmerling,K GYM				
ATH 203LB - 2.0 UNITS BASKETBALL, MEN, OFF SEASON INTERCOLLEGIATE Transferable to UC, CSU 28799 12.0 HRS ARR May,R GYM Class# 28799 meets 01/13/2020-03/13/2020					ATH 233LB - 2.0 UNITS WATER POLO, MEN, OFF SEASON INTERCOLLEGIATE Transferable to UC, CSU 25143 6.0 HRS ARR Abing,J POOL				
ATH 204L - 1.5 UNITS BASKETBALL, WOMEN Transferable to UC, CSU 25126 10.0 HRS ARR Kozlowski,T GYM Class# 25126 meets 01/13/2020-03/13/2020					ATH 235LB - 2.0 UNITS WATER POLO, WOMEN, OFF SEASON INTERCOLLEGIATE Transferable to UC, CSU 25144 6.0 HRS ARR Macias,S POOL				
ATH 205LD - 0.5 UNIT BASKETBALL, WOMEN, OFF SEASON INTERCOLLEGIATE Transferable to UC, CSU 25127 3.0 HRS ARR Kozlowski,T GYM Class# 25127 meets 03/23/2020-05/20/2020					ATH 237LB - 2.0 UNITS WRESTLING, MEN, OFF SEASON INTERCOLLEGIATE Transferable to UC, CSU 25145 6.0 HRS ARR Garriott,D GYM				
ATH 207LB - 2.0 UNITS CROSS COUNTRY, MEN, OFF SEASON INTERCOLLEGIATE Transferable to UC, CSU 25128 6.0 HRS ARR STAFF K 108					ATH 240 - 2.0 UNITS CHEERLEADING Transferable to UC, CSU 30154 6.0 HRS ARR Haley Peaslee,D GYM				
ATH 209LB - 2.0 UNITS CROSS COUNTRY, WOMEN, OFF SEASON INTERCOLLEGIATE Transferable to UC, CSU 25129 6.0 HRS ARR STAFF K 108					ATH 241 - 2.0 UNITS CHEERLEADING, OFF-SEASON Transferable to UC, CSU 30155 6.0 HRS ARR Haley Peaslee,D GYM				
ATH 211LB - 2.0 UNITS FOOTBALL, MEN, OFF SEASON INTERCOLLEGIATE Transferable to UC, CSU 25130 6.0 HRS ARR Caines,T K 108 25131 6.0 HRS ARR Grosfeld,S K 108 25132 6.0 HRS ARR STAFF K 108					ATH 242 - 2.0 UNITS CHEERLEADING COMPETITION Transferable to UC, CSU 30156 6.0 HRS ARR Haley Peaslee,D GYM				
ATH 213LB - 2.0 UNITS SOCCER, MEN, OFF SEASON INTERCOLLEGIATE Transferable to UC, CSU 25133 6.0 HRS ARR Artiaga,B SOCR					<div style="background-color: #008080; color: white; padding: 10px; text-align: center; font-weight: bold; font-size: 1.2em;"> AUTOMOTIVE COLLISION REPAIR & REFINISHING/AUTOBODY </div> AB 51 - 4.5 UNITS NON-STRUCTURAL REPAIR Not Transferable 20181 8:00-9:30AM MW Ferre,C AT 55 9:30-11:50AM MW Ferre,C AT 60 Please read the technical standards relevant to this department at https://www.cerritos.edu/technology/standards.htm . 28641 6:00-7:30PM TTh Roehrs,K AT 55 7:30-9:50PM TTh Roehrs,K AT 60				
ATH 215LB - 2.0 UNITS SOCCER, WOMEN, OFF SEASON INTERCOLLEGIATE Transferable to UC, CSU 25134 6.0 HRS ARR Gonzalez,R SOCR									
ATH 216L - 3.0 UNITS SOFTBALL, WOMEN Transferable to UC, CSU 25135 10.0 HRS ARR Murray,K PE									
ATH 218L - 3.0 UNITS SWIMMING, MEN Transferable to UC, CSU 25136 10.0 HRS ARR Abing,J POOL									
ATH 220L - 3.0 UNITS SWIMMING, WOMEN Transferable to UC, CSU 25137 10.0 HRS ARR Macias,S POOL									
ATH 222L - 3.0 UNITS TENNIS, MEN Transferable to UC, CSU 25138 10.0 HRS ARR STAFF CTS									
ATH 224L - 3.0 UNITS TENNIS, WOMEN Transferable to UC, CSU 25139 10.0 HRS ARR STAFF CTS									
ATH 226L - 3.0 UNITS TRACK AND FIELD, MEN Transferable to UC, CSU 25140 10.0 HRS ARR Richardson,C STADT									
AB 52 - 4.5 UNITS STRUCTURAL DAMAGE REPAIR Not Transferable Recommendation: AB 51 or AB 57 or equivalent with a grade of "C" or higher or "Pass". 29998 7:00-8:30AM TTh Ferre,C AT 50 8:30-11:05AM TTh Ferre,C AT 55									
AB 54 - 4.5 UNITS ADVANCED-DESIGN PANEL REPAIR Not Transferable Recommendation: AB 51 or AB 56 or AB 57 or equivalent with a grade of "C" or higher or "Pass". 28644 6:00-7:30PM MW Chisum,A AT 55 7:30-9:50PM MW Chisum,A AT 50									
AB 57 - 2.0 UNITS STRUCTURAL AUTOMOTIVE WELDING Not Transferable Recommendation: AB 56 or equivalent with a grade of "C" or higher or "Pass" or concurrent enrollment. 29573 1:00-2:30PM TTh Chisum,A AT 50 2:30-4:50PM TTh Chisum,A AT 60 Class# 29573 meets 03/24/2020-05/21/2020									
AB 58L - 1.5 UNITS COLLISION REPAIR LAB Transferable to CSU Prerequisite: AB 51 or equivalent with a grade of "C" or higher or "Pass" or concurrent enrollment. 26939 7:30-9:50PM MW Chisum,A AT 55									

Students not in attendance or late for the first class meeting are subject to drop.

Class#	Time	Day	Instructor	Room	Class#	Time	Day	Instructor	Room
28647	7:30-9:50PM	TTh	Roehrs,K	AT 60	21093	7:00-9:50PM	T	Baron,T	AT 14
29570	9:30-11:50AM	MW	Ferre,C	AT 60	Class# 21093 meets 03/24/2020-05/19/2020				
30000	8:30-11:05AM	TTh	Ferre,C	AT 55	AUTO 100 - 4.0 UNITS AUTOMOTIVE MAINTENANCE AND OPERATION				
AB 62 - 4.5 UNITS OVERALL AND MULTI-COAT REFINISHING					Transferable to CSU				
Not Transferable					20245	8:00-9:30AM	MW	Vega,F	AT 11
Recommendation: AB 51 or AB 61 or equivalent with a grade of "C" or higher or "Pass".					20246	9:30-10:50AM	MW	Vega,F	AT 25
29576	6:00-7:30PM	TTh	Chisum,A	AP12A	20246	8:00-9:30AM	TTh	Vega,F	AT 11
	7:30-9:50PM	TTh	Chisum,A	AT 70		9:30-10:50AM	TTh	Vega,F	AT 25
AB 64 - 2.5 UNITS AUTOMOTIVE AIR BRUSH PAINTING					20811	7:00-8:30PM	MW	Tedtaotao,D	AT 11
Not Transferable						8:30-9:50PM	MW	Tedtaotao,D	AT 25
Recommendation: AB 61 or equivalent with a grade of "C" or higher or "Pass", or related work experience.					20812	7:00-8:30PM	TTh	Glick,L	AT 11
28753	9:00-9:50PM	MW	Ferre,C	AP12A		8:30-9:50PM	TTh	Glick,L	AT 25
	6:00-9:00PM	MW	Ferre,C	AT 70	29586	8:00-11:00AM	F	Treadwell,G	AT 11
Class# 28753 meets 03/23/2020-05/20/2020						11:00-2:00PM	F	Treadwell,G	AT 25
AB 65 - 2.0 UNITS MIX AND ADJUSTING COLOR					AUTO 101 - 4.0 UNITS AUTOMOTIVE SERVICE TOOLS AND EQUIPMENT				
Not Transferable					Transferable to CSU				
Recommendation: AB 61 or equivalent with a grade of "C" or higher or "Pass".					Recommendation: AUTO 100 or equivalent with a grade of "C" or higher or "Pass".				
28648	8:50-10:15PM	MW	Ferre,C	AT 70	27919	8:00-9:30AM	TTh	Gallagher,P	A21
	6:00-8:50PM	MW	Ferre,C	AT 70		9:30-10:50AM	TTh	Gallagher,P	A24
Class# 28648 meets 01/13/2020-03/11/2020					AUTO 107 - 3.0 UNITS DIESEL EXHAUST EMISSION CONTROL AND SERVICING				
AB 83A - 1.5 UNITS COMPUTERIZED DAMAGE ESTIMATING - AUDATEX					Transferable to CSU				
Not Transferable					Recommendation: AUTO 109 or equivalent with a grade of "C" or higher or "Pass".				
Recommendation: Proficient in MS Windows Software application.					29588	6:30-9:50PML	M	Chavez,P	AT 21
28650	6:00-9:00PM	Th	Corzo,R	AT 54	Class# 29588 meets 02/03/2020-05/18/2020				
	9:00-9:50PM	Th	Corzo,R	AT 54	AUTO 110 - 5.0 UNITS AUTOMOTIVE ENGINES				
Class# 28650 meets 03/26/2020-05/21/2020					Transferable to CSU				
AB 83P - 1.5 UNITS COMPUTERIZED DAMAGE ESTIMATING - PATHWAYS					Recommendation: AUTO 100 or equivalent with a grade of "C" or higher or "Pass".				
Not Transferable					20813	6:30-8:30PM	TTh	Vasilik,R	AT 21
Recommendation: Proficient in MS Windows Software application.						8:30-10:20PM	TTh	Vasilik,R	AT 25
27051	6:00-9:00PM	T	Corzo,R	AT 54	AUTO 120 - 5.0 UNITS AUTOMATIC TRANSMISSIONS AND TRANSAXLES				
	9:00-9:50PM	T	Corzo,R	AT 54	Transferable to CSU				
Class# 27051 meets 03/24/2020-05/19/2020					Recommendation: AUTO 100 or equivalent with a grade of "C" or higher or "Pass", or appropriate work experience.				
AB 88 - 3.0 UNITS ESTIMATING AND MANAGEMENT UPDATE					21761	6:30-8:30PM	TTh	Taylor,K	AT 10
Not Transferable						8:30-10:20PM	TTh	Taylor,K	AT 25
26180	6:00-8:30PM	M	Tabares,R	AT 54	AUTO 121 - 6.0 UNITS DRIVETRAIN TRANSMISSIONS AND AXLES				
	8:30-9:50PM	M	Tabares,R	AT 54	Transferable to CSU				
AB 182 - 3.0 UNITS STRUCTURAL DAMAGE ESTIMATING					Recommendation: AUTO 181 and AUTO 73/74 or equivalent with grades of Pass or "C" or higher.				
Transferable to CSU					21050	12:30-3:10PM	MTWTh	Taylor,K	AT 10
Recommendation: AB 181 or equivalent with a grade of "C" or higher or "Pass", or appropriate work experience.						3:10-5:40PM	MTWTh	Taylor,K	AT 25
26182	6:00-8:30PM	M	Tabares,R	AT 54	Class# 21050 meets 03/23/2020-05/21/2020				
	8:30-9:50PM	M	Tabares,R	AT 54	27977	12:30-3:10PM	MTWTh	Mulleary,J	AT 61
						3:10-5:40PM	MTWTh	Mulleary,J	AT 62
					Class# 27977 meets 03/23/2020-05/21/2020				
					AUTO 130 - 5.0 UNITS MANUAL DRIVETRAIN AND AXLES				
					Transferable to CSU				
					Recommendation: AUTO 100 or equivalent with a grade of "C" or higher or "Pass".				
					28600	8:00-10:00AM	TTh	Maine,R	AT 10
						10:00-11:50AM	TTh	Maine,R	AT 25
					AUTO 140 - 5.0 UNITS AUTOMOTIVE STEERING AND SUSPENSION				
					Transferable to CSU				
					Recommendation: AUTO 100 or equivalent with a grade of "C" or higher or "Pass", or appropriate work experience.				
29584	6:30-8:00PM	TTh	Gallagher,P	A26	25644	8:00-10:00AM	MW	Duque,J	AT 46
	8:00-9:30PM	TTh	Gallagher,P	A25		10:00-11:50AM	MW	Duque,J	AT 45
Please read the technical standards relevant to this department at https://www.cerritos.edu/technology/standards.htm .					AUTO 150 - 5.0 UNITS AUTOMOTIVE BRAKES				
AUTO 73 - 3.0 UNITS AUTOMOTIVE MECHANICAL REPAIR OCCUPATIONAL WORK EXPERIENCE					Transferable to CSU				
Not Transferable					Recommendation: AUTO 100 or equivalent with a grade of "C" or higher or "Pass", or appropriate work experience.				
22379	7:00-9:50PM	M	Taylor,K	AP12B	21763	6:30-8:30PM	MW	STAFF	AT 46
Class# 22379 meets 01/13/2020-03/09/2020						8:30-10:20PM	MW	STAFF	AT 45
21145	7:00-9:50PM	T	Bender,W	AP12B					
Class# 21145 meets 01/14/2020-03/10/2020									
27916	7:00-9:50PM	M	Glick,L	AP12B					
Class# 27916 meets 03/23/2020-05/18/2020									

AUTOMOTIVE MECHANICAL REPAIR TECHNOLOGY

Students not in attendance or late for the first class meeting are subject to drop.

Class#	Time	Day	Instructor	Room	Class#	Time	Day	Instructor	Room
AUTO 151 - 6.0 UNITS AUTOMOTIVE ALIGNMENT BRAKE AND SUSPENSION Transferable to CSU					AUTO 281 - 5.0 UNITS EMISSION CONTROL SYSTEMS -1997 STANDARDS Transferable to CSU Recommendation: AUTO 100 or equivalent with a grade of "C" or higher or "Pass".				
21048	12:30-3:00PM	MTWTh	Glick,L	AT 46					
	3:00-5:35PM	MTWTh	Glick,L	AT 45					
Class# 21048 meets 01/13/2020-03/12/2020					20814 6:30-8:30PM MW Baron,T AT 61 8:30-10:30PM MW Baron,T AT 62				
21110	12:30-3:13PM	MTWTh	Bender,W	AT 46					
	3:13-5:40PM	MTWTh	Bender,W	AT 45					
Class# 21110 meets 03/23/2020-05/21/2020									
AUTO 155 - 2.0 UNITS MEDIUM/HEAVY DUTY BRAKE SYSTEMS Transferable to CSU									
29589	6:00-7:36PM	F	STAFF	AT 26					
	7:36-9:10PM	F	STAFF	AT 26					
Class# 29589 meets 02/07/2020-05/22/2020									
AUTO 160 - 2.0 UNITS INTRO TO AUTOMOTIVE ELECTRICAL Transferable to CSU									
30220	6:30-8:30PM	TTh	Gonzalez,J	AT 61					
	8:30-10:20PM	TTh	Gonzalez,J	AT 62					
Class# 29589 meets 02/07/2020-05/22/2020									
AUTO 161 - 7.0 UNITS AUTOMOTIVE ELECTRICITY Transferable to CSU Recommendation: AUTO 100 or AUTO 151 and AUTO 73/74 or equivalent with grades of Pass or "C" or higher.									
29593	6:30-8:30PM	MWF	Jacobo,C	AT 10					
	8:30-9:35PM	MWF	Jacobo,C	AT 25					
21049	12:30-3:30PM	MTWTh	Mulleary,J	AT 61					
	3:30-5:35PM	MTWTh	Mulleary,J	AT 62					
Class# 21049 meets 01/13/2020-03/12/2020									
AUTO 170 - 4.0 UNITS AUTOMOTIVE AIR CONDITIONING Transferable to CSU Recommendation: AUTO 160 or equivalent with a grade of "C" or higher or "Pass", or appropriate work experience.									
29595	6:30-8:00PM	MW	Bender,W	AT 14					
	8:00-9:20PM	MW	Bender,W	AT 25					
AUTO 181 - 6.0 UNITS ELECTRONIC ENGINE MANAGEMENT SYSTEMS-CORPORATE Transferable to CSU Recommendation: AUTO 100 and AUTO 73/74 or equivalent with grades of Pass or "C" or higher.									
21486	12:30-3:00PM	MTWTh	Baron,T	AT 14					
	3:00-5:35PM	MTWTh	Baron,T	AT 25					
Class# 21486 meets 01/13/2020-03/12/2020									
AUTO 182 - 3.5 UNITS INTRODUCTION TO ALTERNATIVE FUEL Transferable to CSU									
29591	7:00-8:55PM	MW	Supple,M	AT 26					
	8:55-9:35PM	MW	Supple,M	AT 25					
Class# 29591 meets 01/13/2020-05/06/2020									
AUTO 195 - 3.0 UNITS AUTOMOTIVE CUSTOMER RELATIONS Transferable to CSU Recommendation: Employment in an automotive repair facility or full-time automotive student.									
29597	7:00-9:50PM	W	Vega,F	AP12B					
Class# 29597 meets 02/05/2020-05/20/2020									
AUTO 211 - 5.0 UNITS HIGH PERFORMANCE ENGINES Transferable to CSU Recommendation: Appropriate work experience.									
24229	6:30-10:20PM	W	Gonzalez,J	AT 21					
	6:30-10:20PM	F	Gonzalez,J	AT 24					
AUTO 212 - 1.0 UNIT ADVANCED HIGH PERFORMANCE ENGINES Transferable to CSU Prerequisite: AUTO 210, Automotive Machine Shop or AUTO 211, High Performance Engines or equivalent with a grade of "C" or higher or "Pass."									
28607	6:30-10:20PM	F	Gonzalez,J	AT 25					
AUTO 260 - 4.0 UNITS INTERMEDIATE AUTOMOTIVE ELECTRICAL Transferable to CSU Prerequisite: AUTO 160 or equivalent with a grade of "C" or higher, or "Pass," or appropriate work experience.									
30115	8:00-9:30AM	MW	Ibarra,B	AT 26					
	9:30-10:50AM	MW	Ibarra,B	AT 25					
					BIOLOGY				
					BIOL 105 - 3.0 UNITS HUMANS AND THE ENVIRONMENT Transferable to UC, CSU Recommendation: ENGL 52 or ENGL 72 or ESL 152 or equivalent with a grade of "C" or higher or "Pass" or completion of the English placement process with a score eligible for ENGL 100.				
	20254	11:00-12:15PM	MW	Valcarcel,A					S 103
	23634	9:30-10:45AM	TTh	Valcarcel,A					S 103
	26911	5:30-6:45PM	MW	STAFF					S 202
	29641	7:00-9:50PM	M	STAFF					S 103
	29642	9:00-11:50AM	F	STAFF					S 103
					BIOL 115 - 3.0 UNITS MARINE BIOLOGY Transferable to UC, CSU				
	26913	12:00-2:00PM	F	Reyes,J					S 127
		2:00-4:50PM	F	Reyes,J					S 127
					BIOL 120 - 4.0 UNITS INTRODUCTION TO BIOLOGICAL SCIENCE Transferable to UC, CSU (CAN BIOL 2) Prerequisite: ENGL 52 or ENGL 72 or ESL 152 or equivalent with a grade of "C" or higher or "Pass" or completion of the English placement process with a score eligible for ENGL 100.				
	20255	11:00-12:15PM	MW	STAFF					S 201
	20258	4:00-6:50PM	M	STAFF					S 121
	20260	3:30-6:20PM	T	STAFF					S 121
	20263	3:30-6:20PM	W	STAFF					S 121
	20256	9:30-10:45AM	MW	Valcarcel,A					S 202
	20262	12:30-3:20PM	W	STAFF					S 121
	20264	8:00-10:50AM	Th	Henderson,S					S 121
	23635	8:00-10:50AM	T	STAFF					S 121
	20820	5:30-6:45PM	TTh	STAFF					S 201
	20821	7:00-9:50PM	M	STAFF					S 121
	20822	7:00-9:50PM	T	STAFF					S 121
	20823	7:00-9:50PM	W	STAFF					S 121
	20824	7:00-9:50PM	Th	STAFF					S 121
	20259	12:30-3:20PM	T	Valcarcel,A					S 121
	20265	12:30-3:20PM	Th	STAFF					S 121
		9:30-10:45AM	TTh	STAFF					S 202
	20257	1:00-3:50PM	M	Valcarcel,A					S 121
	20266	3:30-6:20PM	Th	STAFF					S 121
		2:00-3:15PM	TTh	STAFF					S 202
	20261	8:00-10:50AM	W	STAFF					S 121
	27132	8:00-10:50AM	M	STAFF					S 121
		12:30-1:45PM	MW	STAFF					S 201
					BIOL 200 - 5.0 UNITS PRINCIPLES OF BIOLOGY Transferable to UC, CSU (CAN BIOL SEQ A) Prerequisite: CHEM 111 or equivalent with a grade of "C" or higher or "Pass" or concurrent enrollment and BIOL 120 or ZOOL 120 or BOT 120 or equivalent with a grade of "C" or higher or "Pass."				
	20267	11:00-12:15PM	MW	Schiefelbein,H					S 127
		1:00-3:50PM	MW	Schiefelbein,H					S 127
	29645	5:00-6:15PM	TTh	STAFF					S 127
		7:00-9:50PM	TTh	STAFF					S 127
					BIOL 201 - 5.0 UNITS PRINCIPLES OF BIOLOGY Transferable to UC, CSU (CAN BIOL SEQ A) Prerequisite: CHEM 111 or equivalent with a grade of "C" or higher or "Pass". BIOL 120 or ZOOL 120 or BOT 120 or equivalent with a grade of "C" or higher or "Pass."				
	20269	8:00-9:15AM	MW	Stieber,M					S 124
		9:30-12:20PM	MW	Stieber,M					S 124
	27783	12:30-1:45PM	TTh	Stieber,M					S 124
		2:00-4:50PM	TTh	Stieber,M					S 124

Students not in attendance or late for the first class meeting are subject to drop.

Class#	Time	Day	Instructor	Room	Class#	Time	Day	Instructor	Room
BIOL 202 - 4.0 UNITS MOLECULAR BIOLOGY/GENETICS					BA 104 - 3.0 UNITS MANAGING CULTURAL DIVERSITY				
Transferable to UC, CSU					Transferable to CSU				
Prerequisite: BIOL 201 and CHEM 211 or equivalents with grades of "C" or higher or "Pass."					21760 6.0 HRS ARR (OL) Hu,J ONLINE				
20825	2:00-3:50PM	TTh	McNulty,S	S 103	Note: For class and textbook information, go to www.cerritos.edu/business-administration .				

BOTANY

BOT 120 - 4.0 UNITS INTRODUCTION TO PLANT SCIENCE				
Transferable to UC, CSU				
Prerequisite: ENGL 52 or ENGL 72 or ESL 152 or equivalent with a grade of "C" or higher or "Pass" or completion of the English placement process with a score eligible for ENGL 100.				
29643	12:30-1:30PM	MW	Covill,M	S 124
29644	1:30-4:20PM	MW	Covill,M	S 124

BUSINESS ADMINISTRATION

BA 100 - 3.0 UNITS FUNDAMENTALS OF BUSINESS				
Transferable to UC, CSU				
20247	8:00-9:15AM	MW	STAFF	BE116
20248	12:30-1:45PM	MW	Ramos,G	SS312
20249	11:00-12:15PM	MW	Wright,W	BE119
21871	11:00-12:15PM	TTh	Grady,J	BE119
24200	2:00-3:15PM	TTh	STAFF	BE116
24201	6:30-9:20PM	M	Grady,J	BE116
22003	12:30-1:45PM	TTh	Ramos,G	SS312
28089	8:00-9:15AM	TTh	Daltro,M	BE119
24203	3.6 HRS ARR	(OL)	Moriarty,C	ONLINE

Note: The \$20 course materials fee includes the eTextbook. For class and textbook information, go to www.cerritos.edu/business-administration.

Class# 24203 meets 01/13/2020-05/01/2020

22004	3.6 HRS ARR	(OL)	Moriarty,C	ONLINE
-------	-------------	------	------------	--------

Note: The \$20 course materials fee includes the eTextbook. For class and textbook information, go to www.cerritos.edu/business-administration.

Class# 22004 meets 02/03/2020-05/22/2020

20815	6:30-9:50PM	Th	STAFF	SS312
Class# 20815 meets 02/06/2020-05/21/2020				
27262	6.0 HRS ARR	(OL)	STAFF	ONLINE

Note: The \$20 course materials fee includes the eTextbook. For class and textbook information, go to www.cerritos.edu/business-administration.

Class# 27262 meets 01/13/2020-03/13/2020

27263	6.0 HRS ARR	(OL)	Hu,J	ONLINE
-------	-------------	------	------	--------

Note: The \$20 course materials fee includes the eTextbook. For class and textbook information, go to www.cerritos.edu/business-administration.

Class# 27263 meets 01/13/2020-03/13/2020

23913	6.0 HRS ARR	(OL)	Hu,J	ONLINE
-------	-------------	------	------	--------

Note: The \$20 course materials fee includes the eTextbook. For class and textbook information, go to www.cerritos.edu/business-administration.

Class# 23913 meets 03/23/2020-05/22/2020

26855	6.0 HRS ARR	(OL)	Moriarty,C	ONLINE
-------	-------------	------	------------	--------

Note: The \$20 course materials fee includes the eTextbook. For class and textbook information, go to www.cerritos.edu/business-administration.

Class# 26855 meets 03/23/2020-05/22/2020

BA 101 - 3.0 UNITS INTERNATIONAL BUSINESS				
Transferable to CSU				
20250	9:30-10:45AM	TTh	Hu,J	(HYBRID) BE116
Class will meet on Tuesday and Thursday of the first week and the instructor will inform the students of future class meetings.				
22541	6.0 HRS ARR	(OL)	Grady,J	ONLINE
Note: For class and textbook information, go to www.cerritos.edu/business-administration .				
Class# 22541 meets 01/13/2020-03/13/2020				
20816	6.0 HRS ARR	(OL)	Gray,G	ONLINE
Note: For class and textbook information, go to www.cerritos.edu/business-administration .				
Class# 20816 meets 03/23/2020-05/22/2020				

21760	6.0 HRS ARR	(OL)	Hu,J	ONLINE
Note: For class and textbook information, go to www.cerritos.edu/business-administration .				
Class# 21760 meets 01/13/2020-03/13/2020				
27218	6.0 HRS ARR	(OL)	Hu,J	ONLINE
Note: For class and textbook information, go to www.cerritos.edu/business-administration .				
Class# 27218 meets 03/23/2020-05/22/2020				
29026	6.0 HRS ARR	(OL)	Hu,J	ONLINE
Note: For class and textbook information, go to www.cerritos.edu/business-administration .				
Class# 29026 meets 03/23/2020-05/22/2020				

BA 106 - 3.0 UNITS HUMAN RESOURCE MANAGEMENT				
Transferable to CSU				
22603	6.0 HRS ARR	(OL)	Van Dine,B	ONLINE
Note: The \$20 course materials fee includes the eTextbook. For class and textbook information, go to www.cerritos.edu/business-administration .				
Class# 22603 meets 01/13/2020-03/13/2020				
22364	6.0 HRS ARR	(OL)	Anaya,J	ONLINE
Note: The \$20 course materials fee includes the eTextbook. For class and textbook information, go to www.cerritos.edu/business-administration .				
Class# 22364 meets 01/13/2020-03/13/2020				
27314	6.0 HRS ARR	(OL)	Van Dine,B	ONLINE

Note: The \$20 course materials fee includes the eTextbook. For class and textbook information, go to www.cerritos.edu/business-administration.

Class# 27314 meets 01/13/2020-03/13/2020

23896	6.0 HRS ARR	(OL)	Earcosa,J	ONLINE
-------	-------------	------	-----------	--------

Note: The \$20 course materials fee includes the eTextbook. For class and textbook information, go to www.cerritos.edu/business-administration.

Class# 23896 meets 03/23/2020-05/22/2020

26159	6.0 HRS ARR	(OL)	Van Dine,B	ONLINE
-------	-------------	------	------------	--------

Note: The \$20 course materials fee includes the eTextbook. For class and textbook information, go to www.cerritos.edu/business-administration.

Class# 26159 meets 03/23/2020-05/22/2020

26708	6.0 HRS ARR	(OL)	Acheson,M	ONLINE
-------	-------------	------	-----------	--------

Note: The \$20 course materials fee includes the eTextbook. For class and textbook information, go to www.cerritos.edu/business-administration.

Class# 26708 meets 03/23/2020-05/22/2020

29159	6.0 HRS ARR	(OL)	Acheson,M	ONLINE
-------	-------------	------	-----------	--------

Note: The \$20 course materials fee includes the eTextbook. For class and textbook information, go to www.cerritos.edu/business-administration.

Class# 29159 meets 03/23/2020-05/22/2020

29213	6.0 HRS ARR	(OL)	Anaya,J	ONLINE
-------	-------------	------	---------	--------

Note: The \$20 course materials fee includes the eTextbook. For class and textbook information, go to www.cerritos.edu/business-administration.

Class# 29213 meets 03/23/2020-05/22/2020

29691	6.0 HRS ARR	(OL)	Paquette,R	ONLINE
-------	-------------	------	------------	--------

Note: The \$20 course materials fee includes the eTextbook. For class and textbook information, go to www.cerritos.edu/business-administration.

Class# 29691 meets 03/23/2020-05/22/2020

BA 107 - 3.0 UNITS HUMAN RELATIONS IN BUSINESS				
Transferable to CSU				
23033	6.0 HRS ARR	(OL)	Livingston,R	ONLINE
Note: The \$20 course materials fee includes the eTextbook. For class and textbook information, go to www.cerritos.edu/business-administration .				
Class# 23033 meets 01/13/2020-03/13/2020				
23777	6.0 HRS ARR	(OL)	Wright,W	ONLINE
Note: The \$20 course materials fee includes the eTextbook. For class and textbook information, go to www.cerritos.edu/business-administration .				
Class# 23777 meets 01/13/2020-03/13/2020				
26711	6.0 HRS ARR	(OL)	Wright,W	ONLINE

Note: The \$20 course materials fee includes the eTextbook. For class and textbook information, go to www.cerritos.edu/business-administration.

Class# 26711 meets 01/13/2020-03/13/2020

26857	6.0 HRS ARR	(OL)	Ciraulo,T	ONLINE
-------	-------------	------	-----------	--------

Note: The \$20 course materials fee includes the eTextbook. For class and textbook information, go to www.cerritos.edu/business-administration.

Class# 26857 meets 01/13/2020-03/13/2020

27316	6.0 HRS ARR	(OL)	Moriarty,C	ONLINE
-------	-------------	------	------------	--------

Note: The \$20 course materials fee includes the eTextbook. For class and textbook information, go to www.cerritos.edu/business-administration.

Class# 27316 meets 03/23/2020-05/22/2020

28497	6.0 HRS ARR	(OL)	Ciraulo,T	ONLINE
-------	-------------	------	-----------	--------

Note: The \$20 course materials fee includes the eTextbook. For class and textbook information, go to www.cerritos.edu/business-administration.

Class# 28497 meets 03/23/2020-05/22/2020

Students not in attendance or late for the first class meeting are subject to drop.

Class#	Time	Day	Instructor	Room	Class#	Time	Day	Instructor	Room
29184	6.0 HRS ARR	(OL)	Fantroy,S	ONLINE	23015	6.0 HRS ARR	(OL)	Baber,J	ONLINE
Note: The \$20 course materials fee includes the eTextbook. For class and textbook information, go to www.cerritos.edu/business-administration . Class# 29184 meets 03/23/2020-05/22/2020					Note: The \$20 course materials fee includes the eTextbook. For class and textbook information, go to www.cerritos.edu/business-administration . Class# 23015 meets 01/13/2020-03/13/2020				
BA 108 - 3.0 UNITS LABOR MANAGEMENT RELATIONS Transferable to CSU					26677	6.0 HRS ARR	(OL)	Dokter,D	ONLINE
28246	6.0 HRS ARR	(OL)	STAFF	ONLINE	Note: The \$20 course materials fee includes the eTextbook. For class and textbook information, go to www.cerritos.edu/business-administration . Class# 26677 meets 01/13/2020-03/13/2020				
Note: For class and textbook information, go to www.cerritos.edu/business-administration . Class# 28246 meets 01/13/2020-03/13/2020					27733	6.0 HRS ARR	(OL)	Acheson,M	ONLINE
29160	6.0 HRS ARR	(OL)	Titel,M	ONLINE	Note: The \$20 course materials fee includes the eTextbook. For class and textbook information, go to www.cerritos.edu/business-administration . Class# 27733 meets 01/13/2020-03/13/2020				
Note: For class and textbook information, go to www.cerritos.edu/business-administration . Class# 29160 meets 03/23/2020-05/22/2020					21996	6.0 HRS ARR	(OL)	Livingston,R	ONLINE
BA 109 - 3.0 UNITS HUMAN RESOURCE DEVELOPMENT Transferable to CSU					Note: The \$20 course materials fee includes the eTextbook. For class and textbook information, go to www.cerritos.edu/business-administration . Class# 21996 meets 03/23/2020-05/22/2020				
27264	6.0 HRS ARR	(OL)	Stevenson,K	ONLINE	26675	6.0 HRS ARR	(OL)	Livingston,R	ONLINE
Note: For class and textbook information, go to www.cerritos.edu/business-administration . Class# 27264 meets 01/13/2020-03/13/2020					Note: The \$20 course materials fee includes the eTextbook. For class and textbook information, go to www.cerritos.edu/business-administration . Class# 26675 meets 03/23/2020-05/22/2020				
29161	6.0 HRS ARR	(OL)	STAFF	ONLINE	26719	6.0 HRS ARR	(OL)	Titel,M	ONLINE
Note: For class and textbook information, go to www.cerritos.edu/business-administration . Class# 29161 meets 03/23/2020-05/22/2020					Note: The \$20 course materials fee includes the eTextbook. For class and textbook information, go to www.cerritos.edu/business-administration . Class# 26719 meets 03/23/2020-05/22/2020				
BA 110 - 3.0 UNITS ADVERTISING Transferable to CSU					29028	6.0 HRS ARR	(OL)	Titel,M	ONLINE
27004	6.0 HRS ARR	(OL)	Elam,C	ONLINE	Note: The \$20 course materials fee includes the eTextbook. For class and textbook information, go to www.cerritos.edu/business-administration . Class# 29028 meets 03/23/2020-05/22/2020				
Note: For class and textbook information, go to www.cerritos.edu/business-administration . Class# 27004 meets 01/13/2020-03/13/2020					BA 115 - 3.0 UNITS MANAGEMENT-BUSINESS Transferable to CSU				
27732	6.0 HRS ARR	(OL)	Jo,J	ONLINE	22007	3.6 HRS ARR	(OL)	Franks Sayed,D	ONLINE
Note: For class and textbook information, go to www.cerritos.edu/business-administration . Class# 27732 meets 03/23/2020-05/22/2020					Note: The \$20 course materials fee includes the eTextbook. For class and textbook information, go to www.cerritos.edu/business-administration . Class# 22007 meets 01/13/2020-05/01/2020				
BA 113 - 3.0 UNITS LEGAL ENVIRONMENT OF BUSINESS Transferable to UC, CSU					22001	11:00-12:30PM	TTh	Franks Sayed,D	SS312
20252	9:30-10:45AM	TTh	Ramos,G	SS312	Class# 22001 meets 02/04/2020-05/21/2020				
21758	9:30-10:45AM	MW	Ramos,G	SS312	20817	6.0 HRS ARR	(OL)	Celestine,M	ONLINE
21759	3.6 HRS ARR	(OL)	Vega III,W	ONLINE	Note: The \$20 course materials fee includes the eTextbook. For class and textbook information, go to www.cerritos.edu/business-administration . Class# 20817 meets 01/13/2020-03/13/2020				
Orientation: Midterm and Final exams to be taken on-campus or online. Further class information is available on www.cerritos.edu/business-administration . Class# 21759 meets 01/13/2020-05/01/2020					23036	6.0 HRS ARR	(OL)	Celestine,M	ONLINE
23914	3.6 HRS ARR	(OL)	Ramos,G	ONLINE	Note: The \$20 course materials fee includes the eTextbook. For class and textbook information, go to www.cerritos.edu/business-administration . Class# 23036 meets 03/23/2020-05/22/2020				
Orientation: Midterm and Final exams to be taken on-campus or online. Further class information is available on www.cerritos.edu/business-administration . Class# 23914 meets 01/13/2020-05/01/2020					26161	6.0 HRS ARR	(OL)	Celestine,M	ONLINE
22000	3.6 HRS ARR	(OL)	Paquette,R	ONLINE	Note: The \$20 course materials fee includes the eTextbook. For class and textbook information, go to www.cerritos.edu/business-administration . Class# 26161 meets 03/23/2020-05/22/2020				
Orientation: Midterm and Final exams to be taken on-campus or online. Further class information is available on www.cerritos.edu/business-administration . Class# 22000 meets 02/03/2020-05/22/2020					26325	6.0 HRS ARR	(OL)	Moriarty,C	ONLINE
27424	6.0 HRS ARR	(OL)	Daltro,M	ONLINE	Note: The \$20 course materials fee includes the eTextbook. For class and textbook information, go to www.cerritos.edu/business-administration . Class# 26325 meets 03/23/2020-05/22/2020				
Orientation: Midterm and Final exams to be taken on-campus or online. Further class information is available on www.cerritos.edu/business-administration . Class# 27424 meets 01/13/2020-03/13/2020					28090	6.0 HRS ARR	(OL)	Baber,J	ONLINE
27425	6.0 HRS ARR	(OL)	Daltro,M	ONLINE	Note: The \$20 course materials fee includes the eTextbook. For class and textbook information, go to www.cerritos.edu/business-administration . Class# 28090 meets 03/23/2020-05/22/2020				
Orientation: Midterm and Final exams to be taken on-campus or online. Further class information is available on www.cerritos.edu/business-administration . Class# 27425 meets 01/13/2020-03/13/2020					BA 117 - 3.0 UNITS INTRODUCTION TO SUPERVISION Transferable to CSU				
27456	6.0 HRS ARR	(OL)	Daltro,M	ONLINE	27318	6.0 HRS ARR	(OL)	STAFF	ONLINE
Orientation: Midterm and Final exams to be taken on-campus or online. Further class information is available on www.cerritos.edu/business-administration . Class# 27456 meets 03/23/2020-05/22/2020					Note: For class and textbook information, go to www.cerritos.edu/business-administration . Class# 27318 meets 03/23/2020-05/22/2020				
29027	6.0 HRS ARR	(OL)	Paquette,R	ONLINE	BA 118 - 3.0 UNITS RETAIL MANAGEMENT Transferable to CSU				
Orientation: Midterm and Final exams to be taken on-campus or online. Further class information is available on www.cerritos.edu/business-administration . Class# 29027 meets 03/23/2020-05/22/2020					23479	6.0 HRS ARR	(OL)	Keshishyan,P	ONLINE
BA 114 - 3.0 UNITS MARKETING Transferable to CSU					Note: The \$20 course materials fee includes the eTextbook. For class and textbook information, go to www.cerritos.edu/business-administration . Class# 23479 meets 01/13/2020-03/13/2020				
26676	11:00-12:15PM	MW	Ramos,G	SS312	28283	6.0 HRS ARR	(OL)	Ghidella,R	ONLINE
Note: The \$20 course materials fee includes the eTextbook. For class and textbook information, go to www.cerritos.edu/business-administration .					Note: The \$20 course materials fee includes the eTextbook. For class and textbook information, go to www.cerritos.edu/business-administration . Class# 28283 meets 01/13/2020-03/13/2020				
20253	6.0 HRS ARR	(OL)	Elam,C	ONLINE	23478	6.0 HRS ARR	(OL)	Livingston,R	ONLINE
Note: The \$20 course materials fee includes the eTextbook. For class and textbook information, go to www.cerritos.edu/business-administration . Class# 20253 meets 01/13/2020-03/13/2020					Note: The \$20 course materials fee includes the eTextbook. For class and textbook information, go to www.cerritos.edu/business-administration . Class# 23478 meets 03/23/2020-05/22/2020				

Students not in attendance or late for the first class meeting are subject to drop.

Class#	Time	Day	Instructor	Room	Class#	Time	Day	Instructor	Room
22865	6.0 HRS ARR	(OL)	Livingston,R	ONLINE	23024	6.0 HRS ARR	(OL)	Wright,W	ONLINE
Note: The \$20 course materials fee includes the eTextbook. For class and textbook information, go to www.cerritos.edu/business-administration. Class# 22865 meets 03/23/2020-05/22/2020					Note: The \$20 course materials fee includes the eTextbook. For class and textbook information, go to www.cerritos.edu/business-administration. Class# 23024 meets 03/23/2020-05/22/2020				
26690	6.0 HRS ARR	(OL)	Ciraulo,J	ONLINE	28094	6.0 HRS ARR	(OL)	Ciraulo,J	ONLINE
Note: The \$20 course materials fee includes the eTextbook. For class and textbook information, go to www.cerritos.edu/business-administration. Class# 26690 meets 03/23/2020-05/22/2020					Note: The \$20 course materials fee includes the eTextbook. For class and textbook information, go to www.cerritos.edu/business-administration. Class# 28094 meets 03/23/2020-05/22/2020				
27315	6.0 HRS ARR	(OL)	Moriarty,C	ONLINE	BA 152 - 3.0 UNITS FUNDAMENTALS OF IMPORTING AND EXPORTING				
Note: The \$20 course materials fee includes the eTextbook. For class and textbook information, go to www.cerritos.edu/business-administration. Class# 27315 meets 03/23/2020-05/22/2020					Transferable to CSU 21525 6.0 HRS ARR (OL) STAFF ONLINE Note: For class and textbook information, go to www.cerritos.edu/business-administration. Class# 21525 meets 03/23/2020-05/22/2020				
BA 120 - 3.0 UNITS MANAGEMENT-ACCOUNTING AND INTERNAL CONTROL					BA 153 - 3.0 UNITS SMALL BUSINESS MANAGEMENT				
Transferable to CSU					Transferable to CSU				
26679	6.0 HRS ARR	(OL)	Ghidella,R	ONLINE	22006	3.6 HRS ARR	(OL)	Jo,J	ONLINE
Note: The \$20 course materials fee includes the eTextbook. For class and textbook information, go to www.cerritos.edu/business-administration. Class# 26679 meets 01/13/2020-03/13/2020					Note: For class and textbook information, go to www.cerritos.edu/business-administration. Class# 22006 meets 02/03/2020-05/22/2020				
26722	6.0 HRS ARR	(OL)	Livingston,R	ONLINE	28095	6.0 HRS ARR	(OL)	Dokter,D	ONLINE
Note: The \$20 course materials fee includes the eTextbook. For class and textbook information, go to www.cerritos.edu/business-administration. Class# 26722 meets 01/13/2020-03/13/2020					Note: For class and textbook information, go to www.cerritos.edu/business-administration. Class# 28095 meets 01/13/2020-03/13/2020				
24205	6.0 HRS ARR	(OL)	Livingston,R	ONLINE	27320	6.0 HRS ARR	(OL)	STAFF	ONLINE
Note: The \$20 course materials fee includes the eTextbook. For class and textbook information, go to www.cerritos.edu/business-administration. Class# 24205 meets 01/13/2020-03/13/2020					Note: For class and textbook information, go to www.cerritos.edu/business-administration. Class# 27320 meets 03/23/2020-05/22/2020				
28093	6.0 HRS ARR	(OL)	Keshishyan,P	ONLINE	BA 155 - 3.0 UNITS INTRODUCTION TO GLOBAL LOGISTICS				
Note: The \$20 course materials fee includes the eTextbook. For class and textbook information, go to www.cerritos.edu/business-administration. Class# 28093 meets 03/23/2020-05/22/2020					Transferable to CSU Recommendation: BA 101 or equivalent with a grade of "C" or higher or "Pass". 23770 3.6 HRS ARR (OL) Brown,S ONLINE Note: For class and textbook information, go to www.cerritos.edu/business-administration. Class# 23770 meets 02/03/2020-05/22/2020				
28578	6.0 HRS ARR	(OL)	Elarcosa,J	ONLINE	BA 156 - 3.0 UNITS MOTIVATIONAL PRESENTATION SKILLS FOR MANAGERS				
Note: The \$20 course materials fee includes the eTextbook. For class and textbook information, go to www.cerritos.edu/business-administration. Class# 28578 meets 03/23/2020-05/22/2020					Transferable to CSU 26729 9:30-10:45AM MW STAFF BE116 23026 3.6 HRS ARR (OL) STAFF ONLINE Note: The \$20 course materials fee includes the eTextbook. For class and textbook information, go to www.cerritos.edu/business-administration. Class# 23026 meets 01/13/2020-05/01/2020				
28579	6.0 HRS ARR	(OL)	Keshishyan,P	ONLINE	25784	6.0 HRS ARR	(OL)	Elarcosa,J	ONLINE
Note: The \$20 course materials fee includes the eTextbook. For class and textbook information, go to www.cerritos.edu/business-administration. Class# 28579 meets 03/23/2020-05/22/2020					Note: The \$20 course materials fee includes the eTextbook. For class and textbook information, go to www.cerritos.edu/business-administration. Class# 25784 meets 01/13/2020-03/13/2020				
BA 121 - 3.0 UNITS SALES					22864 6.0 HRS ARR (OL) Fantroy,S ONLINE				
Transferable to CSU					Note: The \$20 course materials fee includes the eTextbook. For class and textbook information, go to www.cerritos.edu/business-administration. Class# 22864 meets 01/13/2020-03/13/2020				
27734	6.0 HRS ARR	(OL)	Ramos,G	ONLINE	27736	6.0 HRS ARR	(OL)	Fantroy,S	ONLINE
Note: For class and textbook information, go to www.cerritos.edu/business-administration. Class# 27734 meets 01/13/2020-03/13/2020					Note: The \$20 course materials fee includes the eTextbook. For class and textbook information, go to www.cerritos.edu/business-administration. Class# 27736 meets 01/13/2020-03/13/2020				
26828	6.0 HRS ARR	(OL)	STAFF	ONLINE	26728	6.0 HRS ARR	(OL)	Garza,J	ONLINE
Note: For class and textbook information, go to www.cerritos.edu/business-administration. Class# 26828 meets 03/23/2020-05/22/2020					Note: The \$20 course materials fee includes the eTextbook. For class and textbook information, go to www.cerritos.edu/business-administration. Class# 26728 meets 01/13/2020-03/13/2020				
BA 126 - 3.0 UNITS E-LEARNING					27737 6.0 HRS ARR (OL) Garza,J ONLINE				
Transferable to CSU					Note: The \$20 course materials fee includes the eTextbook. For class and textbook information, go to www.cerritos.edu/business-administration. Class# 27737 meets 03/23/2020-05/22/2020				
28580	3.6 HRS ARR	(OL)	Garza,J	ONLINE	29693	6.0 HRS ARR	(OL)	STAFF	ONLINE
Note: For class and textbook information, go to www.cerritos.edu/business-administration. Class# 28580 meets 01/13/2020-05/01/2020					Note: The \$20 course materials fee includes the eTextbook. For class and textbook information, go to www.cerritos.edu/business-administration. Class# 29693 meets 03/23/2020-05/22/2020				
BA 132 - 3.0 UNITS COMPUTER APPLICATIONS FOR MANAGERS					BA 157 - 3.0 UNITS PRINCIPLES OF PUBLIC RELATIONS				
Transferable to CSU					Transferable to CSU				
22265	6.0 HRS ARR	(OL)	Ciraulo,T	ONLINE	26730	6.0 HRS ARR	(OL)	Munoz,D	ONLINE
Note: The \$20 course materials fee includes the eTextbook. For class and textbook information, go to www.cerritos.edu/business-administration. Class# 22265 meets 01/13/2020-03/13/2020					Note: For class and textbook information, go to www.cerritos.edu/business-administration. Class# 26730 meets 01/13/2020-03/13/2020				
27012	6.0 HRS ARR	(OL)	Moriarty,C	ONLINE					
Note: The \$20 course materials fee includes the eTextbook. For class and textbook information, go to www.cerritos.edu/business-administration. Class# 27012 meets 01/13/2020-03/13/2020									
29692	6.0 HRS ARR	(OL)	Ciraulo,J	ONLINE					
Note: The \$20 course materials fee includes the eTextbook. For class and textbook information, go to www.cerritos.edu/business-administration. Class# 29692 meets 01/13/2020-03/13/2020									
27007	6.0 HRS ARR	(OL)	STAFF	ONLINE					
Note: The \$20 course materials fee includes the eTextbook. For class and textbook information, go to www.cerritos.edu/business-administration. Class# 27007 meets 03/23/2020-05/22/2020									
25870	6.0 HRS ARR	(OL)	Wright,W	ONLINE					
Note: The \$20 course materials fee includes the eTextbook. For class and textbook information, go to www.cerritos.edu/business-administration. Class# 25870 meets 03/23/2020-05/22/2020									

Students not in attendance or late for the first class meeting are subject to drop.

Class#	Time	Day	Instructor	Room	Class#	Time	Day	Instructor	Room
28096	6.0 HRS ARR		STAFF	ONLINE					
<p>Note: For class and textbook information, go to www.cerritos.edu/business-administration. Class# 28096 meets 03/23/2020-05/22/2020</p>									
BA 204 - 3.0 UNITS PROJECT MANAGEMENT									
Transferable to CSU									
27322	6.0 HRS ARR	(OL)	Brown,S	ONLINE					
<p>Note: For class and textbook information, go to www.cerritos.edu/business-administration. Class# 27322 meets 03/23/2020-05/22/2020</p>									
BA 205 - 3.0 UNITS ORGANIZATIONAL LEADERSHIP									
Transferable to CSU									
23771	3.6 HRS ARR	(OL)	Akini,P	ONLINE					
<p>Note: For class and textbook information, go to www.cerritos.edu/business-administration. Class# 23771 meets 01/13/2020-05/01/2020</p>									
29162	6.0 HRS ARR	(OL)	Stevenson,K	ONLINE					
<p>Note: For class and textbook information, go to www.cerritos.edu/business-administration. Class# 29162 meets 03/23/2020-05/22/2020</p>									
BA 208 - 3.0 UNITS LEADERSHIP FOR WOMEN IN BUSINESS									
Transferable to UC, CSU									
25732	6.0 HRS ARR	(OL)	Livingston,B (Women's Studies)	ONLINE					
<p>Note: For class and textbook information, go to www.cerritos.edu/business-administration. Class# 25732 meets 03/23/2020-05/22/2020</p>									
24206	6.0 HRS ARR	(OL)	Livingston,B (Women's Studies)	ONLINE					
<p>Note: For class and textbook information, go to www.cerritos.edu/business-administration. Class# 24206 meets 01/13/2020-03/13/2020</p>									
29029	6.0 HRS ARR	(OL)	Livingston,B (Women's Studies)	ONLINE					
<p>Note: For class and textbook information, go to www.cerritos.edu/business-administration. Class# 29029 meets 03/23/2020-05/22/2020</p>									
BUSINESS COMMUNICATIONS OFFICE TECHNOLOGY									
BCOT 46 - 3.0 UNITS BUSINESS COMMUNICATIONS									
Not Transferable									
28774	3.0 HRS ARR	(OL)	Sharp,M	ONLINE					
<p>Orientation: All class information will be available in Canvas. Class is offered only in the Spring semester.</p>									
BCOT 62 - 1.0 UNIT COMPUTER KEYBOARDING									
Not Transferable									
21051	2.0 HRS ARR	(OL)	Sharp,M	ONLINE					
	+ 1.0 HRS ARR	(OL)	Sharp,M	ONLINE					
<p>Orientation: All class information will be available in Canvas. Class# 21051 meets 01/13/2020-03/13/2020</p>									
BCOT 63 - 1.0 UNIT KEYBOARDING SPEED/CONTROL BUILDING									
Not Transferable									
Recommendation: Knowledge of keyboard and key strokes.									
21112	2.0 HRS ARR	(OL)	Lopez,L	ONLINE					
	+ 1.0 HRS ARR	(OL)	Lopez,L	ONLINE					
<p>Orientation: All class information will be available in Canvas Class# 21112 meets 03/23/2020-05/22/2020</p>									
BCOT 96 - 1.5 UNITS MICROSOFT POWERPOINT									
Not Transferable									
29166	3.0 HRS ARR	(OL)	Wyszpolski,J	ONLINE					
	+ 2.0 HRS ARR	(OL)	Wyszpolski,J	ONLINE					
<p>Orientation: All class information will be available in Canvas. Class# 29166 meets 03/23/2020-05/22/2020</p>									
BCOT 97 - 1.5 UNITS MICROSOFT OUTLOOK									
Not Transferable									
21517	3.0 HRS ARR	(OL)	Doucette,E	ONLINE					
	+ 2.0 HRS ARR	(OL)	Doucette,E	ONLINE					
<p>Orientation: All class information will be available in Canvas. Class# 21517 meets 03/23/2020-05/22/2020</p>									
BCOT 112 - 3.5 UNITS MICROSOFT WORD									
Transferable to CSU									
Recommendation: Ability to type 30 wpm.									
21519	3.0 HRS ARR	(OL)	Sharp,M	ONLINE					
	+ 2.0 HRS ARR	(OL)	Sharp,M	ONLINE					
<p>Orientation: All class information will be available in Canvas.</p>									
BCOT 113 - 3.5 UNITS MICROSOFT EXCEL									
Transferable to CSU									
21998	3.0 HRS ARR	(OL)	Doucette,E	ONLINE					
	+ 2.0 HRS ARR	(OL)	Doucette,E	ONLINE					
<p>Orientation: All class information will be available in Canvas.</p>									
24207	3.0 HRS ARR	(OL)	Doucette, E	ONLINE					
	+2.0 HRS ARR	(OL)	Doucette, E	ONLINE					
<p>Orientation: All class information will be available in Canvas.</p>									
BCOT 114 - 3.5 UNITS INTRODUCTION TO MICROSOFT OFFICE									
Transferable to CSU									
Recommendation: Ability to type 30 wpm.									
21521	3.0 HRS ARR	(OL)	Soden,B	ONLINE					
	+ 2.0 HRS ARR	(OL)	Soden,B	ONLINE					
<p>Orientation: All class information will be available in Canvas.</p>									
BCOT 118 - 1.5 UNITS MICROSOFT ACCESS FOR OFFICE TECHNOLOGY									
Transferable to CSU									
22140	3.0 HRS ARR	(OL)	Wyszpolski,J	ONLINE					
	+ 2.0 HRS ARR	(OL)	Wyszpolski,J	ONLINE					
<p>Orientation: All class information will be available in Canvas. Class# 22140 meets 03/23/2020-05/22/2020</p>									
BCOT 147 - 3.0 UNITS BUSINESS COMMUNICATIONS									
Transferable to CSU									
Prerequisite: BCOT 46 or equivalent with a grade of "C" or higher or "Pass"									
29705	8:00-9:15AM	MW	Doucette,E (HYBRID)	BE121					
<p>Class will meet on Monday and Wednesday during the first week. The instructor will inform students of subsequent class meetings. All class information will also be available in Canvas. This class is offered only in the Spring semester.</p>									
BCOT 148 - 3.0 UNITS EFFECTIVE BUSINESS PRESENTATIONS									
Transferable to CSU									
Recommendation: Completion of BCOT 96 and BCOT 147 or equivalent with a grade of "C" or higher, or "Pass".									
30007	3.0 HRS ARR	(OL)	Doucette,E	ONLINE					
<p>Orientation: All class information will be available in Canvas.</p>									
BCOT 150 - 3.0 UNITS INTERNATIONAL BUSINESS COMMUNICATION									
Transferable to CSU									
Recommendation: BCOT 147 or ENGL 100 or equivalent with a grade of "C" or higher or "Pass".									
29706	6.0 HRS ARR		STAFF	ONLINE					
<p>Orientation: All class information will be available in Canvas. Class# 29706 meets 03/23/2020-05/22/2020</p>									
BCOT 155 - 4.0 UNITS ADMINISTRATIVE SECRETARIAL PROCEDURES									
Transferable to CSU									
Recommendation: BCOT 131 or equivalent with a grade of "C" or higher or "Pass".									
26165	3.6 HRS ARR	(OL)	Wyszpolski,J	ONLINE					
	+ 2.4 HRS ARR	(OL)	Wyszpolski,J	ONLINE					
<p>Orientation: All class information will be available in Canvas. Class is offered only in the Spring semester. Class# 26165 meets 02/03/2020-05/22/2020</p>									
BCOT 161 - 1.0 UNIT PRINCIPLES OF FILING									
Transferable to CSU									
25737	2.0 HRS ARR	(OL)	Lopez,L	ONLINE					
	+ 1.0 HRS ARR	(OL)	Lopez,L	ONLINE					
<p>Orientation: All class information will be available in Canvas. Class is offered only in the Spring semester. Class# 25737 meets 03/23/2020-05/22/2020</p>									

Students not in attendance or late for the first class meeting are subject to drop.

Class#	Time	Day	Instructor	Room	Class#	Time	Day	Instructor	Room
BCOT 247 - 3.0 UNITS MANAGERIAL BUSINESS COMMUNICATIONS					CHEM 110 - 4.0 UNITS ELEMENTARY CHEMISTRY				
Transferable to CSU					Transferable to UC, CSU				
Prerequisite: ENGL 100 or equivalent with a grade of "C" or higher or "Pass"					Prerequisite: MATH 80 or MATH 80B or equivalent with a grade of "C" or higher				
24212	10:00-11:15AM	MW	Sharp,M	BE120	(HYBRID)				
Class will meet on Monday and Wednesday during the first week. The instructor will inform students of subsequent class meetings. All class information will also be available in Canvas. This class is offered only in the Spring semester.					MATH courses numbered 100 level or higher.				
27014	3.0 HRS ARR	(OL)	Sharp,M	ONLINE	Recommendation: Meet the prerequisite within four years prior to the date of enrollment in CHEM 110.				
Orientation: All class information will be available in Canvas.					20292	1:00-2:15PM	MW	Mathur,R	MCIS207
29180	3.0 HRS ARR	(OL)	Sharp,M	ONLINE	20295	2:30-5:20PM	W	Mathur,R	S 219
Orientation: All class information will be available in Canvas.					20293	11:00-12:15PM	MW	STAFF	MCIS207
					22725	8:00-10:50AM	W	STAFF	S 219
					20294	11:00-12:20PM	TTh	Rajeckas,A	S 219
					20297	8:00-10:50AM	T	Rajeckas,A	S 219
					20296	12:30-1:45PM	TTh	STAFF	S 219
					22900	8:00-10:50AM	Th	Rajeckas,A	S 219
					20839	2:00-3:15PM	TTh	Bonness Jr.,N	S 102
					20840	11:00-1:50PM	W	Bradbury,J	S 219
					23871	5:30-6:45PM	TTh	Nguyen,H	S 219
					23872	7:00-9:50PM	T	Nguyen,H	S 219
					29651	8:00-9:30AM	MW	STAFF	S 102
					29652	8:00-10:50AM	F	STAFF	S 219
					29659	5:30-6:45PM	MW	STAFF	S 219
					29660	7:00-9:50PM	W	STAFF	S 219

CHEMISTRY

CHEMISTRY DEPARTMENT COURSE SEQUENCE

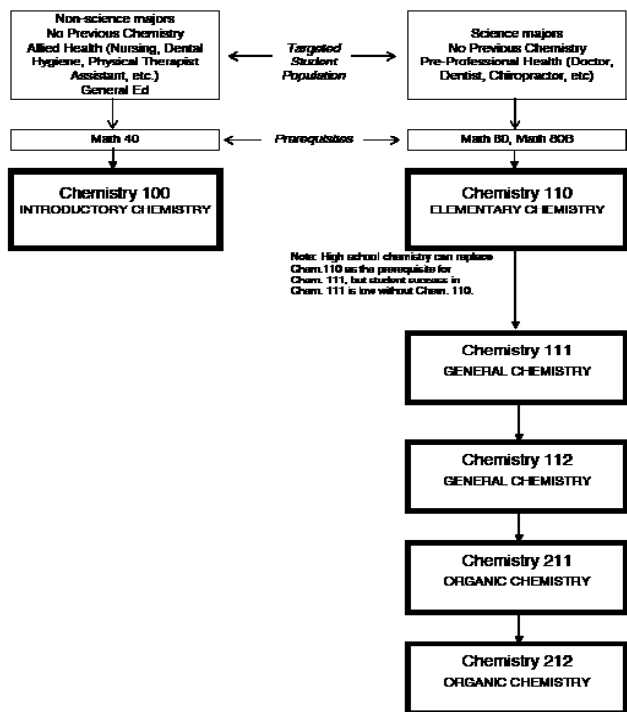

CHEM 100 - 4.0 UNITS INTRODUCTORY CHEMISTRY

Transferable to UC, CSU (CAN CHEM 6)
Prerequisite: MATH 40 or equivalent with a grade of "C" or higher or "Pass" or completion of the math placement process with a score eligible for MATH 60.
Recommendation: Meet the prerequisite within four years prior to the date of enrollment in CHEM 100.

20286	8:00-9:15AM	MW	Waldman,L	S 201
20291	9:30-12:20PM	W	Waldman,L	S 215
29650	8:00-10:50AM	F	STAFF	S 215
20287	12:30-1:45PM	TTh	Waldman,L	S 201
20288	8:00-10:50AM	T	Khodaghlian,S	S 215
20289	8:00-10:50AM	Th	Khodaghlian,S	S 215
20838	11:00-1:50PM	T	STAFF	S 215
23605	11:00-1:50PM	Th	STAFF	S 215
	9:30-10:45AM	TTh	Waldman,L	S 102
28224	5:30-6:45PM	MW	STAFF	S 215
28225	7:00-9:50PM	W	STAFF	S 215
21926	5:00-6:15PM	TTh	Dukhovny,O	S 215
21927	7:00-9:50PM	Th	Nguyen,H	S 215

CHEM 111 - 5.0 UNITS GENERAL CHEMISTRY

Transferable to UC, CSU (CAN CHEM 2)(CAN CHEM SEQ A)
Prerequisite: CHEM 110 or equivalent with a grade of "C" or higher or "Pass" and MATH 80 or MATH 80B or equivalent with a grade of "C" or higher or "Pass" or completion of the math placement process with a score eligible for MATH courses numbered 100 level or higher.
Recommendation: Meet the prerequisite within four years prior to the date of enrollment in CHEM 111.

20298	12:30-1:45PM	TTh	Bradbury,J	MCIS211
20299	2:00-4:50PM	TTh	Bradbury,J	S 222
27168	5:30-6:45PM	MW	Bonness Jr.,N	S 224
27169	2:00-4:50PM	MW	Bonness Jr.,N	S 224
20841	5:30-6:45PM	MW	Ho,T	S 102
20842	7:00-9:50PM	MW	Ho,T	S 222
22901	11:00-12:15PM	MW	Moskun,A	S 102
22902	8:00-10:50AM	MW	Moskun,A	S 222
29655	2:00-3:15PM	TTh	STAFF	MCIS207
29656	11:00-1:50PM	TTh	STAFF	S 224
29657	5:30-6:45PM	TTh	STAFF	S 224
29658	7:00-9:50PM	TTh	STAFF	S 224

CHEM 112 - 5.0 UNITS GENERAL CHEMISTRY

Transferable to UC, CSU (CAN CHEM 4)(CAN CHEM SEQ A)
Prerequisite: CHEM 111 or equivalent with a grade of "C" or higher or "Pass."
Recommendation: It is strongly recommended that the preceding prerequisite be completed within four years prior to the date of enrollment in CHEM 112.

20302	9:30-10:45AM	TTh	Shimazu,C	S 201
20303	11:00-1:50PM	TTh	Shimazu,C	S 222
20844	5:30-6:45PM	MW	Bradbury,J	S 222
20845	2:00-4:50PM	MW	Bradbury,J	S 222
27785	12:30-1:45PM	TTh	Moskun,A	S 102
27786	8:00-10:50AM	TTh	Moskun,A	S 222
29653	5:30-6:45PM	TTh	Bonness Jr.,N	S 102
29654	7:00-9:50PM	TTh	Bonness Jr.,N	S 222

CHEM 211 - 5.0 UNITS ORGANIC CHEMISTRY

Transferable to UC, CSU
Prerequisite: CHEM 112 or equivalent with a grade of "C" or higher or "Pass."
Recommendation: It is strongly recommended that the preceding prerequisite be completed within four years prior to the date of enrollment in CHEM 211.

26112	9:30-10:45AM	MW	Dahl Jr.,M	S 102
26113	11:00-1:50PM	MW	STAFF	S 224
27340	8:30-2:20PM	F	Dahl Jr.,M	S 224

CHEM 212 - 5.0 UNITS ORGANIC CHEMISTRY

Transferable to UC, CSU
Prerequisite: CHEM 211 or equivalent with a grade of "C" or higher or "Pass."
Recommendation: It is strongly recommended that the preceding prerequisite be completed within four years prior to the date of enrollment in CHEM 212.

20307	12:30-1:45PM	TTh	Lou,R	MCIS207
20309	8:00-10:50AM	MW	Lou,R	S 224
26114	8:00-10:50AM	TTh	Lou,R	S 224

CHEM 250L - 1.0 UNIT SPECIAL TOPICS IN CHEMISTRY

Transfer CSU, UC determined after admission
Prerequisite: CHEM 111 or equivalent with a grade of "C" or higher or "Pass."
21540 3.0 HRS ARR Waldman,L

Students not in attendance or late for the first class meeting are subject to drop.

Class#	Time	Day	Instructor	Room	Class#	Time	Day	Instructor	Room
--------	------	-----	------------	------	--------	------	-----	------------	------

CHILD DEVELOPMENT

**Earn a Bachelor's Degree with the
University of La Verne**

Camden College and La Verne have created a partnership to provide students an opportunity to earn a Bachelor's degree in child development. Students may take La Verne upper division courses while completing Camden CE courses. This program has been accredited by both institutions.



HS Child Development
For more information contact
Christine Camacho
(909) 993-3110, Ext. 5436

Note: Earn a Bachelor's Degree in Child Development from the University of LaVerne. For information call (909) 593-3511, extension 5436.

CD 110 - 3.0 UNITS CHILD DEVELOPMENT

Transferable to UC, CSU (CAN HEC 14)

22545	11:00-1:50PM	W	Andrade,O	HS101
Note: Targeted for Future Teachers but Open to all Students				
22392	8:00-10:50AM	W	Beck,A	HS101
Note: Targeted for Future Teachers but Open to all Students				
20277	2:00-4:50PM	M	Gradin,S	HS101
Note: Targeted for Future Teachers but Open to all Students				
23274	8:00-10:50AM	Th	Andrade,O	SL107
Note: Targeted for Future Teachers but Open to all Students				
20830	2:00-4:50PM	T	Beck,A	HS101
Note: Targeted for Future Teachers but Open to all Students				
21485	3.0 HRS ARR	(OL)	Beck,A	ONLINE
Mandatory orientation: 9:00 a.m. - 12:00 p.m., Friday, January 17, 2020 in SL 109.				
25158	7:00-9:50PM	T	Gibson,D	HS104
Note: Targeted for Future Teachers but Open to all Students				
26899	11:00-1:50PM	F	Gradin,S	HS101
29553	11:00-1:50PM	M	Pullman,S	HS101
30122	7:00-9:50PM	M	Banh,M	HS102
27283	9:00-12:10PM	Sat	Roque,G	HS101
Class# 27283 meets 01/18/2020-05/16/2020				

CD 124 - 3.0 UNITS TEACHING IN A DIVERSE SOCIETY

Transferable to CSU

22501	7:00-9:50PM	W	Palma,J	HS104
22224	2:00-4:50PM	Th	Palma,J	SL107

CD 139 - 3.0 UNITS OBSERVATION, ASSESSMENT, AND POSITIVE GUIDANCE OF CHILDHOOD

Transferable to CSU

Recommendation: CDEC 111 and CD 110 or equivalent with grades of Pass or "C" or higher.

23275	2:00-4:50PM	W	Gibson,D	HS101
21873	7:00-9:50PM	Th	Gibson,D	HS101

CDEC 112 - 3.0 UNITS INTRODUCTION TO CURRICULUM

Transferable to CSU

23279	8:00-10:50AM	T	Tharuvai,S	HS101
21889	7:00-9:50PM	M	Andrade,O	HS101
25657	2:00-4:50PM	Th	Black,K	HS101

CDEC 113 - 3.0 UNITS THE CHILD, FAMILY, AND COMMUNITY

Transferable to CSU

23280	8:00-10:50AM	Th	Beck,A	HS101
20283	7:00-9:50PM	M	Palma,J	HS103
20834	11:00-1:50PM	M	Palma,J	SL107

CDEC 133 - 3.0 UNITS EARLY CHILDHOOD EXPERIENCES IN MATHEMATICS AND SCIENCE

Transferable to CSU

Prerequisite: CDEC 112 or equivalent with a grade of "C" or higher or "Pass".

23281	7:00-9:50PM	MW	Gibson,D	SL107
(HYBRID)				
Class# 23281 meets 01/13/2020-03/11/2020				

CDEC 161 - 3.0 UNITS HEALTH, SAFETY, AND NUTRITION

Transferable to CSU

22503	3.0 HRS ARR	(OL)	Beck,A	ONLINE
23282	7:00-9:50PM	W	Sandoval,Y	HS101

CDEC 164 - 3.0 UNITS PRACTICUM FIELD EXPERIENCE

Transferable to CSU

Prerequisite: CD 110, CDEC 111, CDEC 112, and CDEC 113 or equivalent with grades of Pass or "C" or higher.

Recommendation: CD 124, CD 139, and CDEC 161.

20835	6:00-7:50PM	W	Ward,D	SL108
+ 3.0 HRS ARR				
21890	7:00-8:50PM	M	Ward,D	HS104
+ 3.0 HRS ARR				

CDEC 167 - 3.0 UNITS ADMINISTRATION II: PERSONNEL AND LEADERSHIP IN EARLY CHILDH

Transferable to CSU

Prerequisite: CDEC 66 or CDEC 166 or equivalent with a grade of "C" or higher or "Pass."

Recommendation: Teaching experience.

26903	7:00-9:50PM	Th	Gradin,S	SL107
-------	-------------	----	----------	-------

CHILD DEVELOPMENT/INFANT TODDLER

CDIT 151 - 3.0 UNITS INFANT AND TODDLER DEVELOPMENT

Transferable to CSU

Recommendation: CD 110 or equivalent with a grade of "C" or higher or "Pass".

23283	2:00-4:50PM	W	Gradin,S	SL107
-------	-------------	---	----------	-------

CDIT 152 - 3.0 UNITS CARE AND EDUCATION FOR INFANTS AND TODDLERS

Transferable to CSU

Recommendation: CD 110 and CDIT 151 or equivalent with grades of Pass or "C" or higher.

20284	7:00-9:50PM	T	Gradin,S	HS101
-------	-------------	---	----------	-------

CHILD DEVELOPMENT/EARLY CHILDHOOD

CDEC 63 - 3.0 UNITS EARLY CHILDHOOD EXPERIENCES IN LANGUAGE ARTS AND SOCIAL SCIE

Not Transferable

Prerequisite: CDEC 112 or equivalent with a grade of "C" or higher or "Pass".

26923	7:00-9:50PM	MW	O'Neill,C	SL107
Class# 26923 meets 03/23/2020-05/20/2020				

CDEC 111 - 3.0 UNITS PRINCIPLES AND PRACTICES IN EARLY CHILDHOOD EDUCATION

Transferable to CSU

20278	8:00-10:50AM	M	Ramirez,M	HS101
20279	7:00-9:50PM	T	Andrade,O	SL107
20280	11:00-1:50PM	F	Palma,J	SL107

CHILD DEVELOPMENT/SPECIAL EDUCATION

CDSE 152 - 3.0 UNITS CURRICULUM AND STRATEGIES FOR CHILDREN WITH SPECIAL NEEDS

Transferable to CSU

26905	7:00-9:50PM	M	Roberts,R	SL108
-------	-------------	---	-----------	-------

Students not in attendance or late for the first class meeting are subject to drop.

Class#	Time	Day	Instructor	Room	Class#	Time	Day	Instructor	Room
CHINESE									
CHIN 101 - 5.0 UNITS ELEMENTARY CHINESE I									
Transferable to UC, CSU									
22817	12:30-2:45PM	MW	Zhou,Y	(HYBRID) LA211	29931	9:30-10:45AM	MW	Hanniff,B	SS207
	+ 1.0 HRS ARR		Zhou,Y	LC205	29934	11:00-12:15PM	MW	STAFF	SS225
LAB IS ONE HOUR PER WEEK IN THE SUCCESS CENTER;*A PORTION OF THE HOURS FOR THIS CLASS WILL BE ONLINE					29936	3:30-4:45PM	TTh	STAFF	SS224
22819	12:30-2:45PM	TTh	Zhou,Y	(HYBRID) LA103	29926	3.6 HRS ARR	(OL)	STAFF	ONLINE
	+ 1.0 HRS ARR		Zhou,Y	LC205	ENROLLED STUDENTS WILL BE CONTACTED BY THE INSTRUCTOR BEFORE THE FIRST DAY OF CLASS.				
LAB IS ONE HOUR PER WEEK IN THE SUCCESS CENTER;*A PORTION OF THE HOURS FOR THIS CLASS WILL BE ONLINE					Class# 29926 meets 02/03/2020-05/22/2020				
CHIN 102 - 5.0 UNITS ELEMENTARY CHINESE II									
Transferable to UC, CSU									
Prerequisite: CHIN 101 or equivalent with a grade of "C" or higher or "Pass".									
22889	3:30-5:45PM	W	Zhou,Y	(HYBRID) LA211	29928	6:30-9:50PM	Th	STAFF	SS225
	+ 1.0 HRS ARR		Zhou,Y	LC205	Class# 29928 meets 02/06/2020-05/21/2020				
LAB IS ONE HOUR PER WEEK IN THE SUCCESS CENTER;*A PORTION OF THE HOURS FOR THIS CLASS WILL BE ONLINE					30083	2:00-3:30PM	MW	STAFF	SS214
					29930	9:30-12:35PM	Sat	STAFF	SS211
					Class# 29930 meets 01/18/2020-05/16/2020				
					29937	6.0 HRS ARR	(OL)	Rosenfeld,K	ONLINE
					ENROLLED STUDENTS WILL BE CONTACTED BY THE INSTRUCTOR BEFORE THE FIRST DAY OF CLASS.				
					Class# 29937 meets 01/13/2020-03/13/2020				
					30082	6.0 HRS ARR	(OL)	STAFF	ONLINE
					ENROLLED STUDENTS WILL BE CONTACTED BY THE INSTRUCTOR BEFORE THE FIRST DAY OF CLASS.				
					Class# 30082 meets 03/23/2020-05/22/2020				
CHIN 260 - 3.0 UNITS CHINESE CULTURE AND SOCIETY					COMM 103 - 3.0 UNITS ARGUMENTATION, PERSUASION, AND CRITICAL THINKING				
Transferable to CSU					Transferable to UC, CSU (CAN SPCH 6)				
Recommendation: ENGL 52 or ENGL 72 or ESL 152 or equivalent with a grade of "C" or higher or "Pass" or completion of the English placement process with a score eligible for ENGL 100.					Prerequisite: Completion of ENGL 100 or equivalent with a grade of "C" or higher or "Pass".				
27766	3.0 HRS ARR	(OL)	Zhou,Y	ONLINE	29977	9:30-10:45AM	TTh	STAFF	SS224
MANDATORY ORIENTATION: INSTRUCTOR WILL CONTACT ENROLLED STUDENTS BEFORE THE START OF THE SEMESTER					29978	12:30-1:45PM	TTh	Mathews,N	SS224
					29979	2:00-3:15PM	TTh	STAFF	SS225
					29980	9:30-10:50AM	MW	STAFF	SS225
					29981	8:00-9:30AM	MW	STAFF	SS225
					Class# 29981 meets 02/03/2020-05/20/2020				
					29982	5:30-7:00PM	MW	STAFF	SS225
					Class# 29982 meets 02/03/2020-05/20/2020				
COMM 60 - 3.0 UNITS BASICS OF SPEECH COMMUNICATION					COMM 110 - 3.0 UNITS INTERCULTURAL COMMUNICATION				
Not Transferable					Transferable to UC, CSU				
29903	7:00-9:50PM	M	STAFF	SS224	Prerequisite: Completion of at least one of these courses with a grade of "C" or higher or "Pass" or an equivalent course: SPCH 60, ENGL 52, ESL 152, READ 54, READ 97, or completion of the English or Reading placement process.				
COMM 100 - 3.0 UNITS INTRODUCTION TO COMMUNICATIONS STUDIES					29938	11:00-12:15PM	TTh	STAFF	SS225
Transferable to UC, CSU (CAN SPCH 2)					29939	12:30-1:45PM	MW	Hoppe-Nagao,A	SS207
Prerequisite: Completion of at least one of these courses with a grade of "C" or higher or "Pass" or an equivalent course: SPCH 60,ENGL 52, ENGL 72, ESL 152, READ 54, READ 97, or completion of the English or Reading Placement process.					29940	6.0 HRS ARR	(OL)	Hoppe-Nagao,A (Honors Section)	ONLINE
29904	8:00-9:15AM	MW	STAFF	SS207	ENROLLED STUDENTS WILL BE CONTACTED BY THE INSTRUCTOR BEFORE THE FIRST DAY OF CLASS.				
29905	4:00-5:15PM	MW	STAFF	SS225	Class# 29940 meets 01/13/2020-03/13/2020				
29906	2:30-3:45PM	MW	STAFF	SS211	29941	6.0 HRS ARR	(OL)	Hoppe-Nagao,A (Honors Section)	ONLINE
29907	7:00-9:50PM	W	STAFF	SS225	ENROLLED STUDENTS WILL BE CONTACTED BY THE INSTRUCTOR BEFORE THE FIRST DAY OF CLASS.				
29908	3:30-4:45PM	MW	STAFF	SS224	Class# 29941 meets 03/23/2020-05/22/2020				
29909	9:30-10:45AM	TTh	Hanniff,B	SS211	COMM 115 - 3.0 UNITS GENDER, COMMUNICATION, AND THE DIGITAL REVOLUTION				
29910	2:00-3:15PM	TTh	STAFF	SS207	Transferable to CSU				
29911	5:30-6:45PM	TTh	STAFF	SS224	Prerequisite: Completion of at least one of these courses with a grade of "C" or higher or "Pass" or an equivalent course: COMM 60,ENGL 52,ENGL72,ESL 152,READ 54,READ 97 or completion of the English or Reading placement/assessment process with eligibility for ENGL 100.				
29912	8:00-9:15AM	TTh	STAFF	SS207	29942	9:30-11:00AM	TTh	Rosenfeld,K	SS225
29913	11:00-12:15PM	TTh	STAFF	SS207	Class# 29942 meets 02/04/2020-05/21/2020				
29914	2:00-3:15PM	MW	STAFF	SS224	29943	6.0 HRS ARR	(OL)	Rosenfeld,K	ONLINE
29915	8:00-9:30AM	TTh	STAFF	LM20*	ENROLLED STUDENTS WILL BE CONTACTED BY THE INSTRUCTOR BEFORE THE FIRST DAY OF CLASS.				
Class# 29915 meets 02/04/2020-05/21/2020					Class# 29943 meets 01/13/2020-03/13/2020				
This class is being held at our satellite campus. La Mirada Center, 15310 Alondra Blvd., La Mirada, 90638 in classroom #20.					29944	6.0 HRS ARR	(OL)	Rosenfeld,K	ONLINE
29916	10:00-11:30AM	TTh	STAFF	LM20*	ENROLLED STUDENTS WILL BE CONTACTED BY THE INSTRUCTOR BEFORE THE FIRST DAY OF CLASS.				
Class# 29916 meets 03/04/2020-05/21/2020					Class# 29944 meets 03/23/2020-05/22/2020				
This class is being held at our satellite campus. La Mirada Center, 15310 Alondra Blvd., La Mirada, 90638 in classroom #20.					COMM 120 - 3.0 UNITS INTERPERSONAL COMMUNICATION				
29917	4:00-6:50PM	Th	STAFF	SS207	Transferable to CSU				
29918	1:00-3:50PM	F	STAFF	SS211	Prerequisite: Completion of at least one of these courses with a grade of "C" or higher or "Pass" or an equivalent course: COMM60,ENGL 52,ENGL72,ESL 152,READ 54,READ 97 or completion of the English or Reading placement/assessment process with eligibility for ENGL 100.				
29919	7:00-9:50PM	T	STAFF	SS225	29945	11:00-12:15PM	TTh	STAFF	SS224
29920	3.0 HRS ARR	(OL)	Hanniff,B	ONLINE	29946	3:30-4:45PM	TTh	STAFF	SS211
ENROLLED STUDENTS WILL BE CONTACTED BY THE INSTRUCTOR BEFORE THE FIRST DAY OF CLASS.					29947	8:00-9:15AM	MW	Hanniff,B	SS211
29922	3.0 HRS ARR	(OL)	STAFF	ONLINE	29948	4:00-5:15PM	MW	STAFF	SS207
ENROLLED STUDENTS WILL BE CONTACTED BY THE INSTRUCTOR BEFORE THE FIRST DAY OF CLASS.					29949	11:00-12:15PM	MW	Hoppe-Nagao,A	SS207
29923	3.0 HRS ARR	(OL)	STAFF	ONLINE	Enrolled students will be contact by the instructors before the first day of class.				
29924	2:00-3:15PM	TTh	STAFF	SS224					
29925	12:30-1:45PM	MW	Hanniff,B	SS224					
29929	12:30-1:45PM	TTh	Hanniff,B	SS225					

Students not in attendance or late for the first class meeting are subject to drop.

Class#	Time	Day	Instructor	Room	Class#	Time	Day	Instructor	Room
29950	9:30-12:20PM	F	STAFF	SS224					
29951	8:00-9:15AM	TTh	STAFF	SS225					
30084	12:30-1:50PM	MW	STAFF	SS225					
29952	7:00-10:20PM	T	STAFF	SS211					
Class# 29952 meets 02/04/2020-05/19/2020									
COMM 125 - 3.0 UNITS ORGANIZATIONAL COMMUNICATION									
Transferable to CSU									
Recommendation: Suggested completion of at least one of these courses with a grade of "C" or higher or "Pass" or an equivalent course: ENGL 72, or ESL 152, or READ 54, or READ 97, or completion of the English, r ESL or Reading placement/assessment process with eligibility for ENGL 100.									
29971	11:00-12:15PM	TTh	STAFF	SS211					
29972	11:00-12:15PM	MW	STAFF	SS211					
Class# 29972 meets 03/23/2020-05/18/2020									
COMM 130 - 3.0 UNITS PUBLIC SPEAKING									
Transferable to UC, CSU (CAN SPCH 4)									
Prerequisite: Completion of at least one of these courses with a grade of "C" or higher or "Pass" or an equivalent course: COMM 60,ENGL 52,ENGL72,ESL 152,READ 54,READ 97 or completion of the English or Reading placement/assessment process with eligibility for ENGL 100.									
29953	2:00-3:15PM	TTh	Mathews,N	SS211					
29954	12:30-1:45PM	TTh	Rosenfeld,K	SS207					
29955	5:30-6:50PM	MW	STAFF	SS207					
29959	8:00-9:15AM	TTh	STAFF	SS211					
29960	7:00-9:50PM	Th	STAFF	SS211					
29961	9:30-11:00AM	TTh	Hoppe-Nagao,A	SS207					
Class# 29961 meets 02/04/2020-05/21/2020									
29962	4:00-5:15PM	MW	STAFF	SS211					
29963	9:30-12:30PM	W	Mathews,N	SS224					
Class# 29963 meets 02/05/2020-05/20/2020									
29964	9:00-12:30PM	F	STAFF	SS211					
Class# 29964 meets 02/07/2020-05/22/2020									
29966	9:30-12:35PM	Sat	STAFF	SS225					
Class# 29966 meets 01/18/2020-05/16/2020									
29958	9:30-12:30PM	M	STAFF	SS224			(HYBRID)		
Note: +2.75 hrs will be held online									
Class# 29958 meets 03/23/2020-05/18/2020									
COMM 132 - 3.0 UNITS SMALL GROUP COMMUNICATION									
Transferable to UC, CSU (CAN SPCH 10)									
Prerequisite: Completion of at least one of these courses with a grade of "C" or higher or "Pass" or an equivalent course: COMM 60,ENGL 52,ENGL72,ESL 152,READ 54,READ 97 or completion of the English or Reading placement/assessment process with eligibility for ENGL 100.									
29967	8:00-9:15AM	TTh	STAFF	SS224					
29968	7:00-10:20PM	W	STAFF	SS224					
Class# 29968 meets 02/05/2020-05/20/2020									
COMM 140 - 3.0 UNITS ORAL INTERPRETATION OF LITERATURE									
Transferable to UC, CSU									
Prerequisite: Completion of at least one of these courses with a grade of "C" or higher or "Pass" or an equivalent course: COMM 60,ENGL 52,ENGL72,ESL 152,READ 54,READ 97 or completion of the English or Reading placement/assessment process with eligibility for ENGL 100.									
29969	12:30-2:00PM	TTh	STAFF	SS211					
Class# 29969 meets 02/04/2020-05/21/2020									
COMM 145 - 3.0 UNITS STORYTELLING									
Transferable to CSU									
29970	9:30-11:00AM	MW	STAFF	SS211					
Class# 29970 meets 02/03/2020-05/20/2020									
COMM 200 - 3.0 UNITS CONTEMPORARY COMMUNICATION TOPICS									
Transferable to CSU									
Recommendation: Suggested completion of at least one of these courses with a grade of "C" or higher or "Pass" or an equivalent course ENGL 72, or ESL 152, or READ 54, or READ 97, or completion of the English, or ESL or Reading assessment/assessment process with eligibility for ENGL 100.									
29973	6.0 HRS ARR	(OL)	Rosenfeld,K	ONLINE					
ENROLLED STUDENTS WILL BE CONTACTED BY THE INSTRUCTOR BEFORE THE FIRST DAY OF CLASS.									
Class# 29973 meets 03/23/2020-05/22/2020									
COMM 231 - 1.0 UNIT FORENSICS ACTIVITY 1 (COMPETITIVE SPEECH AND DEBATE)									
Transferable to CSU									
29974	1.0 HRS ARR		Mathews,N	SS225					
This class meets on Tuesday and Thursday from 4:00-5:30 in SS225.									
Class# 29974 meets 01/13/2020-05/22/2020									

COMM 232 - 2.0 UNITS FORENSICS ACTIVITY 2 (COMPETITIVE SPEECH AND DEBATE)									
Transferable to CSU									
29975	2.0 HRS ARR		Mathews,N	SS225					
This class meets on Tuesday and Thursday from 4:00-5:30 in SS225.									
Class# 29975 meets 01/13/2020-05/22/2020									
COMM 233 - 3.0 UNITS FORENSICS ACTIVITY 3 (COMPETITIVE SPEECH AND DEBATE)									
Transferable to CSU									
29976	3.0 HRS ARR		STAFF	SS225					
This class meets on Tuesday and Thursday from 4:00-5:30 in SS224.									
Class# 29976 meets 01/13/2020-05/22/2020									

COMPUTER AND INFORMATION SCIENCES

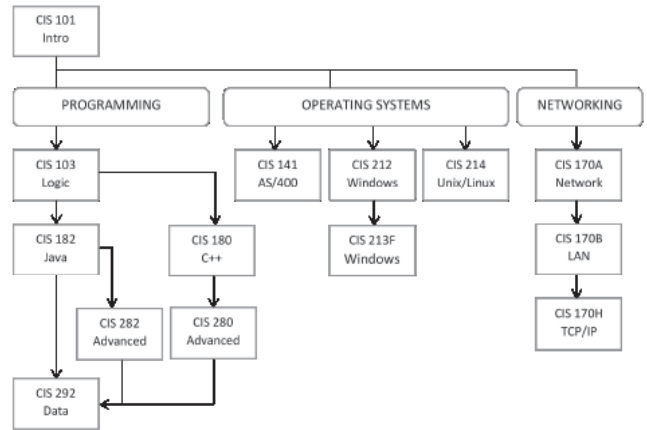

CIS 58A - 3.5 UNITS PC OPERATING SYSTEM A+ CERTIFICATION
 Not Transferable
 Recommendation: CIS 101 or CIS 102 or equivalent with a grade of "C" or higher or "Pass" or appropriate work experience.

To Prepare for the CompTIA A+ Certification
 Take the following courses:
 CIS 102 Intro Microworld Hardware
 CIS 58A PC Operating System A+ Certification
 CIS 58B PC Core Hardware A+ Certification
 For more information, contact:
 Kenny Lou at klou@cerritos.edu or
 Gene LaZor at glazor@cerritos.edu

25772	6.0 HRS ARR	(OL)	STAFF	ONLINE
	+ 4.0 HRS ARR	(OL)	STAFF	ONLINE
Note: An on-campus orientation is required for this course. Orientation will meet: 8:00-10:00 a.m., Saturday - January 18 in MCIS 205 at Cerritos College				
Class# 25772 meets 01/13/2020-03/13/2020				

CIS 58B - 3.5 UNITS PC CORE HARDWARE A+ CERTIFICATION				
Not Transferable				
Recommendation: CIS 101 or CIS 102 or equivalent with a grade of "C" or higher or "Pass" or appropriate work experience.				
20310	1:00-2:30PM	MTWTh	Lazor,C	(HYBRID) MCIS205
	2:30-3:30PM	MTWTh	Lazor,C	(HYBRID) MCIS205
Note: A portion of this class will be online.				
Class# 20310 meets 03/23/2020-05/22/2020				
26106	6.0 HRS ARR	(OL)	Lazor,C	ONLINE
	+ 4.0 HRS ARR	(OL)	Lazor,C	ONLINE
Note: An on-campus orientation is required for this course. Orientation will meet: 1:00-3:50 p.m., Tuesday - March 24 in MCIS 205 at Cerritos College				
Class# 26106 meets 03/23/2020-05/22/2020				

Students not in attendance or late for the first class meeting are subject to drop.

Class#	Time	Day	Instructor	Room	Class#	Time	Day	Instructor	Room
CIS 101 - 3.0 UNITS INTRODUCTION TO COMPUTER INFORMATION SYSTEMS					30131 5:00-7:50PM M STAFF (HYBRID) MCIS209				
Transferable to UC, CSU (CAN BUS 6)					8:00- 9:50PM M STAFF (HYBRID) MCIS209				
CIS 101 meets important Computer Literacy Requirements for ALL majors and transfers as a Computer Course Requirement to most 4-year universities in the area.					Note: A portion of this class will be online.				
20314	11:00-12:15PM	MW	STAFF	MCIS211	26851	3.6 HRS ARR	(OL)	STAFF	ONLINE
	10:00-10:50AM	W	STAFF	MCIS213		+ 2.4 HRS ARR	(OL)	STAFF	ONLINE
20315	1:00-2:15PM	MW	STAFF	(HYBRID) MCIS211	Note: An on-campus orientation is required for this course. Orientation will meet: 5:00-7:00 p.m., Friday - February 7 in MCIS 208 at Cerritos College.				
	3:00-4:00PM	W	STAFF	(HYBRID) MCIS213	Class# 26851 meets 02/03/2020-05/22/2020				
Note: A portion of this class will be online.					28285 6:30-10:00PM W STAFF (HYBRID) MCIS208				
20317	9:30-10:45AM	TTh	STAFF	MCIS209	4:00- 6:20PM W STAFF (HYBRID) MCIS208				
	11:00-11:50AM	T	STAFF	MCIS213	Note: A portion of this class will be online.				
20320	9:00-11:50AM	F	STAFF	MCIS209	Class# 28285 meets 02/05/2020-05/20/2020				
	12:00-12:50PM	F	STAFF	MCIS213	CIS 155 - 3.0 UNITS MICROSOFT ACCESS				
20846	7:00-9:50PM	W	STAFF	(HYBRID) MCIS211	Transferable to CSU				
	6:00-6:50PM	W	STAFF	(HYBRID) MCIS206	Recommendation: CIS 102 or equivalent with a grade of "C" or higher or "Pass".				
Note: A portion of this class will be online.					20852 3.0 HRS ARR (OL) STAFF ONLINE				
20847	3.0 HRS ARR	(OL)	STAFF	ONLINE	+ 2.0 HRS ARR (OL) STAFF ONLINE				
	+ 1.0 HRS ARR	(OL)	STAFF	ONLINE	Note: An on-campus orientation is required for this course. Orientation will meet: 5:00-7:00 p.m., Friday - January 17 in MCIS 210 at Cerritos College.				
Note: An on-campus orientation is required for this course. Orientation will meet: 11:00-1:00 p.m., Saturday - January 18 in MCIS 207 at Cerritos College.					CIS 160 - 3.5 UNITS WEB PAGE DEVELOPMENT				
20849	3.0 HRS ARR	(OL)	Lazor,C	ONLINE	Transferable to CSU				
	+ 1.0 HRS ARR	(OL)	Lazor,C	ONLINE	This course involves web page development with interactive graphics, animation, and sound using HTML, DSS, Dreamweaver, and Flash for personal and commercial use.				
Note: An on-campus orientation is required for this course. Orientation will meet: 11:00-1:00 p.m., Saturday - January 18 in MCIS 205 at Cerritos College.					For more information contact: Phuong Nguyen, email: pnguyen@cerritos.edu				
20850	6:00-8:50PM T		Lazor,C	(HYBRID) MCIS207	21810	5:00-7:50PM T		STAFF	(HYBRID) MCIS211
	5:00-5:50PM T		Lazor,C	(HYBRID) MCIS206		8:00-9:50PM T		STAFF	(HYBRID) MCIS211
Note: A portion of this class will be online.					Note: A portion of this class will be online.				
28783	3.0 HRS ARR	(OL)	Nance,W	ONLINE	27305	3.0 HRS ARR	(OL)	STAFF	ONLINE
	+ 1.0 HRS ARR	(OL)	Nance,W	ONLINE	+ 2.0 HRS ARR (OL) STAFF ONLINE				
Mandatory Orientation: See website http://www.cerritos.edu/nance for orientation document and quiz due 1/13/20					Note: An on-campus orientation is required for this course. Orientation will meet: 5:00-7:00 p.m., Tuesday - January 14 in MCIS 211 at Cerritos College.				
21114	3.6 HRS ARR	(OL)	STAFF	ONLINE	CIS 162 - 3.5 UNITS HTML AND CSS				
	+ 1.2 HRS ARR	(OL)	STAFF	ONLINE	Transferable to CSU				
Note: An on-campus orientation is required for this course. Orientation will meet: 7:00-9:00 p.m., Friday - February 7 in MCIS 209 at Cerritos College.					Recommendation: CIS 101 or CIS 102 or equivalent with a grade of "C" or higher or "Pass."				
	Class# 21114 meets 02/03/2020-05/22/2020				23638	3.0 HRS ARR	(OL)	Lazor,C	ONLINE
28678	6.0 HRS ARR	(OL)	STAFF	ONLINE	+ 2.0 HRS ARR (OL) Lazor,C ONLINE				
	+ 2.0 HRS ARR	(OL)	STAFF	ONLINE	Note: An on-campus orientation is required for this course. Orientation will meet: 9:00-11:00 a.m., Saturday - January 18 in MCIS 205 at Cerritos College.				
Note: An on-campus orientation is required for this course. Orientation will meet: 11:00-1:00 p.m., Saturday - January 18 in MCIS 211 at Cerritos College.					24137 5:00-7:50PM T Lazor,C (HYBRID) MCIS205				
	Class# 28678 meets 01/13/2020-03/13/2020				8:00-9:50PM T Lazor,C (HYBRID) MCIS205				
27793	6.0 HRS ARR	(OL)	STAFF	ONLINE	Note: A portion of this class will be online.				
	+ 2.0 HRS ARR	(OL)	STAFF	ONLINE	CIS 164 - 3.5 UNITS JAVASCRIPT PROGRAMMING				
Note: An on-campus orientation is required for this course. Orientation will meet: 9:00-11:00 a.m., Saturday - March 28 in MCIS 207 at Cerritos College.					Transferable to CSU				
	Class# 27793 meets 03/23/2020-05/22/2020				Prerequisite: CIS 103 and CIS 162 or equivalents with grades of "C" or higher or "Pass."				
CIS 102 - 3.0 UNITS INTRODUCTION TO MICROCOMPUTER HARDWARE AND APPLICATIONS SOFT					29663 5:00-7:50PM M STAFF (HYBRID) MCIS207				
Transferable to UC, CSU					8:00-9:50PM M STAFF (HYBRID) MCIS206				
21802	3.0 HRS ARR	(OL)	Nance,W	ONLINE	Note: A portion of this class will be online.				
	+ 2.0 HRS ARR	(OL)	Nance,W	ONLINE	CIS 170A - 3.5 UNITS NETWORKING FUNDAMENTALS				
Mandatory Orientation: See website http://www.cerritos.edu/nance for orientation document and quiz due 1/13/20					Transferable to CSU				
CIS 103 - 3.5 UNITS COMPUTER PROGRAMMING LOGIC					Cisco Networking Academy at Cerritos College				
Transferable to UC, CSU					Cisco Course Cerritos Course				
Recommendation: Concurrent enrollment in or completion of CIS 101 or CIS 102 or equivalent with a grade of "C" or higher or "Pass. CIS 103 meet the Computer Logic requirements for students in a wide selection of majors including Computer Science, Math, Engineering, Business, and many of the Social Sciences.					CCNA 1 Networking Fundamentals CIS 170A				
20322	3.0 HRS ARR	(OL)	Nguyen,P	ONLINE	CCNA 2 Router Configuration CIS 170E				
	+ 2.0 HRS ARR	(OL)	Nguyen,P	ONLINE	CCNA 3 Advanced Switching & Routing CIS 170F				
Note: An on-campus orientation is required for this course. Orientation will meet: 5:00-6:30 p.m., Friday - January 17 in MCIS 211 at Cerritos College.					CCNA 4 Wide Area Networks CIS 170G				
20323	1:00-3:50PM	T	STAFF	(HYBRID) MCIS209	Other courses for the Networking Certification at Cerritos College				
	1:00- 2:50PM	Th	STAFF	(HYBRID) MCIS208	CIS 170B Local Area Networks				
Note: A portion of this class will be online.					CIS 170H Introduction to TCP/IP				
20324	5:00-7:50PM Th		Nguyen,P	(HYBRID) MCIS211	Preparation for the Cisco CCNA and CCNP, the Network +, and the Microsoft MCSE certifications involves the fundamental knowledge of networks learned in CIS 170A				
	8:00- 9:50PM Th		Nguyen,P	(HYBRID) MCIS213	24122 8:00-10:50AM T STAFF (HYBRID) MCIS205				
Note: A portion of this class will be online.					8:00-9:50AM Th STAFF (HYBRID) MCIS205				
23729	3.0 HRS ARR	(OL)	Nguyen,P	ONLINE	Note: A portion of this class will be online.				
	+ 2.0 HRS ARR	(OL)	Nguyen,P	ONLINE	24147	6.0 HRS ARR	(OL)	Lou,Z	ONLINE
Note: An on-campus orientation is required for this course. Orientation will meet: 6:30-8:00 p.m., Friday - January 17 in MCIS 211 at Cerritos College.					+ 4.0 HRS ARR (OL) Lou,Z ONLINE				
					Mandatory Orientation - See website http://www.cerritos.edu/klou for orientation instructions				
					Class# 24147 meets 01/13/2020-03/13/2020				

Students not in attendance or late for the first class meeting are subject to drop.

Class#	Time	Day	Instructor	Room	Class#	Time	Day	Instructor	Room
CIS 170B - 3.5 UNITS NETWORK + CERTIFICATION									
Transferable to CSU									
24149	6.0 HRS ARR	(OL)	Lou,Z	ONLINE					
	+ 4.0 HRS ARR	(OL)	Lou,Z	ONLINE					
Mandatory Orientation - See website http://www.cerritos.edu/klou for orientation instructions									
Class# 24149 meets 03/23/2019-05/24/2019									
CIS 170E - 3.5 UNITS ROUTER CONFIGURATIONS AND PROTOCOL									
Transferable to CSU									
Prerequisite: CIS 170A (formerly CIS 70A) or equivalent with a grade of "C" or higher or "Pass" or appropriate work experience.									
23640	5:00-8:00PM	W	Lazor,C	(HYBRID) MCIS205					
	8:00-9:50PM	W	Lazor,C	(HYBRID) MCIS205					
Note: A portion of this class will be online.									
CIS 170F - 3.5 UNITS ADVANCED SWITCHING AND ROUTING									
Transferable to CSU									
Prerequisite: CIS 170E (formerly CIS 70E) or equivalent with a grade of "C" or higher or "Pass" or appropriate work experience.									
24139	3.0 HRS ARR	(OL)	Lazor,C	ONLINE					
	+ 2.0 HRS ARR	(OL)	Lazor,C	ONLINE					
Note: An on-campus orientation is required for this course. Orientation will meet: 5:00-7:00 p.m., Wednesday - January 15 in MCIS 205 at Cerritos College.									
CIS 170G - 3.5 UNITS WIDE AREA NETWORKS									
Transferable to CSU									
Prerequisite: CIS 170E (formerly CIS 70E) or equivalent with a grade of "C" or higher or "Pass" or appropriate work experience.									
24141	3.0 HRS ARR	(OL)	Lazor,C	ONLINE					
	+ 2.0 HRS ARR	(OL)	Lazor,C	ONLINE					
Note: An on-campus orientation is required for this course. Orientation will meet: 5:00-7:00 p.m., Wednesday - January 15 in MCIS 205 at Cerritos College.									
CIS 170H - 3.0 UNITS TCP/IP FUNDAMENTALS									
Transferable to CSU									
Recommendation: A knowledge of Web browser and e-mail applications.									
26866	6.0 HRS ARR	(OL)	Lou,Z	ONLINE					
Mandatory Orientation - See website http://www.cerritos.edu/klou for orientation instructions									
Class# 26866 meets 03/23/2019-05/24/2019									
CIS 170K - 3.0 UNITS INTRODUCTION TO WIRELESS NETWORKING									
Transferable to CSU									
30133	3.0 HRS ARR	(OL)	STAFF	ONLINE					
Note: An on-campus orientation is required for this course. Orientation will meet: 9:00-11:00 a.m., Saturday - January 18 in MCIS 202 at Cerritos College.									
CIS 170P - 3.5 UNITS INTRODUCTION TO ETHICAL HACKING									
Transferable to CSU									
Recommendation: CIS 170A with a grade of "C" or higher or "Pass" or a knowledge of networking concepts or related work experience.									
26108	5:00-8:00PM	Th	Lou,Z	MCIS202					
	8:00-9:50PM	Th	Lou,Z	MCIS202					
26110	3.0 HRS ARR	(OL)	Lou,Z	ONLINE					
	+ 2.0 HRS ARR	(OL)	Lou,Z	ONLINE					
Mandatory Orientation - See website http://www.cerritos.edu/klou for orientation instructions									
CIS 170R - 3.5 UNITS COMPUTER AND DIGITAL FORENSICS									
Transferable to CSU									
Recommendation: CIS 58A with a grade of "C" or higher or "Pass" or a knowledge of computer operating systems or related work experience.									
27795	3.0 HRS ARR	(OL)	Lou,Z	ONLINE					
	+ 2.0 HRS ARR	(OL)	Lou,Z	ONLINE					
Mandatory Orientation - See website http://www.cerritos.edu/klou for orientation instructions									
CIS 180 - 3.0 UNITS PROGRAMMING IN C/C++									
Transferable to UC, CSU									
Prerequisite: CIS 103 or equivalent with a grade of "C" or higher or "Pass." CIS 180 is important for most Computer Science majors and is required for many Math majors for transfer to Universities. C++ is still the programming language of choice for many large corporations.									
27787	5:00-7:50PM	T	Nguyen,P	(HYBRID) MCIS202					
	8:00- 9:50PM	T	Nguyen,P	(HYBRID) MCIS213					
Note: A portion of this class will be online.									
30134	3.6 HRS ARR	(OL)	STAFF	ONLINE					
Class# 30134 meets 02/03/2020-05/22/2020									
30135	3.6 HRS ARR	(OL)	STAFF	ONLINE					
Note: An on-campus orientation is required for this course. Orientation will meet: 6:00-8:00 p.m., Friday - February 7 in MCIS 210 at Cerritos College. Class# 30135 meets 02/03/2020-05/22/2020									
CIS 183 - 3.0 UNITS JAVA PROGRAMMING									
Transferable to CSU									
Prerequisite: CIS 103 or equivalent with a grade of "C" or higher or "Pass." CIS 183 is required for all Computer Science majors for transfer to Universities.									
26096	8:00-10:50AM	T	STAFF	(HYBRID) MCIS204					
	8:00-9:50AM	Th	STAFF	(HYBRID) MCIS204					
Note: A portion of this class will be online. Class meetings most weeks are on campus for lecture.									
26098	3.0 HRS ARR	(OL)	STAFF	ONLINE					
	+ 2.0 HRS ARR	(OL)	STAFF	ONLINE					
Note: An on-campus orientation is required for this course. Orientation will meet: 9:00-11:00 a.m., Saturday - January 18 in MCIS 210 at Cerritos College.									
26100	5:00-7:50PM	T	Mellas,D	(HYBRID) MCIS209					
	8:00-9:50PM	T	Mellas,D	(HYBRID) MCIS208					
Note: A portion of this class will be online. .									
28781	3.0 HRS ARR	(OL)	STAFF	ONLINE					
	+ 2.0 HRS ARR	(OL)	STAFF	ONLINE					
Note: An on-campus orientation is required for this course. Orientation will meet: 5:00-7:00 p.m., Friday - January 17 in MCIS 208 at Cerritos College.									
CIS 185 - 3.0 UNITS DISCRETE STRUCTURES									
Transferable to UC, CSU									
Prerequisite: CIS 183 or equivalent with a grade of "C" or higher or "Pass."									
28156	5:00-8:00PM	F	Nguyen,P	(HYBRID) MCIS207					
	8:00-8:50PM	F	Nguyen,P	(HYBRID) MCIS208					
Note: A portion of this class will be online.									
CIS 189C - 3.0 UNITS SPECIAL TOPICS IN SOFTWARE DEVELOPMENT									
Transfer CSU, UC determined after admission									
29049	3.6 HRS ARR	(OL)	STAFF	ONLINE					
Note: An on-campus orientation is required for this course. Orientation will meet: 5:00-7:00 p.m., Friday - February 7 in MCIS 206 at Cerritos College. Class# 29049 meets 02/03/2020-05/22/2020									
CIS 200A - 3.5 UNITS APPLE MAC OS SUPPORT ESSENTIALS									
Transferable to CSU									
Recommendation: A knowledge of computer operating systems or appropriate work experience.									
26682	5:00-7:50PM	M	Lou,Z	(HYBRID) MCIS202					
	8:00- 9:50PM	M	Lou,Z	(HYBRID) MCIS204					
Note: An on-campus orientation is required for this course. Orientation will meet: 9:00-11:00 a.m., Saturday - February 8 in MCIS 207 at Cerritos College.									
CIS 202A - 3.5 UNITS PROJECT MANAGEMENT FOR INFORMATION TECHNOLOGY									
Transferable to CSU									
Recommendation: CIS 102 and CIS 105 or equivalents with grades of "C" or higher or "Pass" or appropriate work experience.									
21919	3.6 HRS ARR	(OL)	STAFF	ONLINE					
	+ 2.4 HRS ARR	(OL)	STAFF	ONLINE					
Note: An on-campus orientation is required for this course. Orientation will meet: 9:00-11:00 a.m., Saturday - February 8 in MCIS 210 at Cerritos College. Class# 21919 meets 02/03/2020-05/22/2020									
CIS 202B - 3.5 UNITS MICROSOFT PROJECT									
Transferable to CSU									
Recommendation: CIS 102 or equivalent with a grade of "C" or higher or "Pass" or appropriate work experience.									
30136	3.0 HRS ARR	(OL)	STAFF	ONLINE					
	+ 2.0 HRS ARR	(OL)	STAFF	ONLINE					
Note: An on-campus orientation is required for this course. Orientation will meet: 9:00-11:00 a.m., Saturday - January 18 in MCIS 208 at Cerritos College.									
CIS 207 - 3.5 UNITS DATABASE DESIGN AND SQL									
Transferable to CSU									
Recommendation: CIS 155 or equivalent with a grade of "C" or higher or "Pass."									
26102	3.0 HRS ARR	(OL)	STAFF	ONLINE					
	+ 2.0 HRS ARR	(OL)	STAFF	ONLINE					
Note: An on-campus orientation is required for this course. Orientation will meet: 9:00-11:00 a.m., Saturday - January 18 in MCIS 206 at Cerritos College.									

Students not in attendance or late for the first class meeting are subject to drop.

Class#	Time	Day	Instructor	Room	Class#	Time	Day	Instructor	Room
CIS 208A - 3.5 UNITS ORACLE SQL AND PL/SQL Transferable to CSU Recommendation: CIS 103 and CIS 155 or equivalent with grades of Pass or "C" or higher or appropriate work experience.					CIS 292 - 3.0 UNITS DATA STRUCTURES Transferable to UC, CSU Prerequisite: CIS 183 or CIS 280X or equivalent of either course with a grade of "C" or higher or "Pass" or appropriate work experience.				
26684	3.0 HRS ARR	(OL)	STAFF	ONLINE	21923	5:00-7:50PM	W	Mellas,D	MCIS209
	+ 2.0 HRS ARR	(OL)	STAFF	ONLINE					
Note: An on-campus orientation is required for this course. Orientation will meet: 9:00-11:00 a.m., Saturday - January 18 in MCIS 206 at Cerritos College.									
CIS 212 - 3.5 UNITS INTRODUCTION TO MICROSOFT WINDOWS ADMINISTRATION Transferable to CSU Recommendation: CIS 58A or equivalent with a grade of "C" or higher or "Pass.									
23646	3.0 HRS ARR	(OL)	STAFF	ONLINE					
	+ 2.0 HRS ARR	(OL)	STAFF	ONLINE					
Note: An on-campus orientation is required for this course. Orientation will meet: 11:00-1:00 p.m., Saturday - January 18 in MCIS 210 at Cerritos College.									
CIS 213F - 3.5 UNITS MICROSOFT WINDOWS SERVER ADMINISTRATION Transferable to CSU Microsoft IT Academy at Cerritos College The CIS program offers courses on the two Microsoft certifications: Microsoft Certified Systems Administrator (MCSA), Microsoft Certified Systems Engineer (MCSE). For Microsoft certification requirements and matching courses, please visit: http://www.cerritos.edu/klou/ . For more information, please contact: Kenny Lou, e-mail: klou@cerritos.edu									
21921	3.0 HRS ARR	(OL)	STAFF	ONLINE					
	+ 2.0 HRS ARR	(OL)	STAFF	ONLINE					
Note: An on-campus orientation is required for this course. Orientation will meet: 11:00-1:00 p.m., Saturday - January 18 in MCIS 210 at Cerritos College.									
CIS 214 - 3.0 UNITS UNIX AND LINUX OPERATING SYSTEMS Transferable to CSU Recommendation: Knowledge of one operating system. CIS 214 now includes all of the material for Linux operating system studies. Students will learn to use the powerful utilities and applications of UNIX and the free, open source Linux operating system. For more information contact: Dean Mellas, email: dmellas@cerritos.edu									
20854	5:00-7:50PM	Th	Mellas,D	(HYBRID) MCIS209					
	8:00-9:50PM	Th	Mellas,D	(HYBRID) MCIS208					
Note: A portion of this class will be online.									
CIS 231 - 3.5 UNITS COMPUTER ORGANIZATION AND ASSEMBLY LANGUAGE PROGRAMMING Transferable to UC, CSU Prerequisite: CIS 180 or CIS 182 or CIS 183 or equivalent with a grade of "C" or higher or "Pass."									
25668	5:00-7:50PM	M	STAFF	MCIS211					
	8:00-9:50PM	M	STAFF	MCIS213					
CIS 280X - 3.5 UNITS OBJECT-ORIENTED PROGRAMMING IN C++ Transferable to CSU Recommendation: Strongly recommend CIS 180 or equivalent with a grade of "C" or higher or "Pass".									
22904	5:00-7:50PM	Th	STAFF	(HYBRID) MCIS204					
	8:00-9:50PM	Th	STAFF	(HYBRID) MCIS206					
Note: A portion of this class will be online.									
CIS 285A - 3.5 UNITS ASP.NET PROGRAMMING Transferable to CSU Recommendation: CIS 162 and CIS 286 or equivalents with grades of "C" or higher or "Pass.									
29667	3.0 HRS ARR	(OL)	STAFF	ONLINE					
	+ 2.0 HRS ARR	(OL)	STAFF	ONLINE					
Note: An on-campus orientation is required for this course. Orientation will meet: 5:00-7:00 p.m., Friday - January 17 in MCIS 206 at Cerritos College.									
CIS 286 - 3.5 UNITS SOFTWARE DEVELOPMENT WITH C# Transferable to CSU Recommendation: Knowledge of one object-oriented programming language.									
29991	2.0 HRS ARR	(OL)	STAFF	ONLINE					
Note: An on-campus orientation is required for this course. Orientation will meet: 5:00-7:00 p.m., Tuesday - January 14 in MCIS 206 at Cerritos College.									
29992	3.0 HRS ARR	(OL)	STAFF	ONLINE					
Note: An on-campus orientation is required for this course. Orientation will meet: 5:00-7:00 p.m., Tuesday - January 14 in MCIS 206 at Cerritos College.									
30138	5:00-7:50PM	T	Nguyen,P	(HYBRID) MCIS210					
	8:00-9:50PM	T	Nguyen,P	(HYBRID) MCIS210					
Note: A portion of this class will be online.									

COSMETOLOGY

COS 53 - 6.5 UNITS ADVANCED COSMETOLOGY MANIPULATION Not Transferable Prerequisite: COS 52C or COS 62B or 70C or COS 73B with a grade of "C" or higher or "Pass". All cosmetology students must purchase the approved equipment kit (Cosmetology approx. \$1350/Esthetician approx. \$625). Students enrolled in an introductory class will be assessed a materials fee for the student kit upon registration. The materials fee must be paid with your enrollment fees through the Office of Admissions and Records. These kits are MANDATORY. Contact the program office for more information at ext. 2950.;Please read the technical standards relevant to this department at http://www.cerritos.edu/technology/standards.htm				
22344	8:00-10:05AM	WThF	Petrova,R	HS205
	10:05-4:50PM	WThF		HS205
Class# 22344 meets 01/13/2020-03/13/2020				
COS 54 - 11.0 UNITS INTRODUCTORY ESTHETICIAN Not Transferable Prerequisite: ENGL 100 or ENGL 100S or equivalent with a grade of "C" or higher or "Pass" and READ 54 or READ 97 or equivalent with a grade of "C" or higher or "Pass" or completion of the Reading placement process with eligibility for "Reading Exempt."				
27198	8:00-10:30AM	MTW	Petrova,R	HS201
	10:30-4:20PM	MTW	Petrova,R	HS201
Class# 27198 meets 03/23/2020-05/22/2020				
COS 54A - 11.0 UNITS ADVANCED ESTHETICIAN Not Transferable Prerequisite: COS 54 or equivalent with a grade of "C" or higher or "Pass".				
27196	8:00-10:30AM	WThF	Ramirez-Han,J	HS203
	10:30-4:20PM	WThF	Ramirez-Han,J	HS203
Class# 27196 meets 01/15/2020-04/20/2020				
COS 55 - 6.5 UNITS ESTHETICS CROSSOVER Not Transferable Prerequisite: ENGL 100 or ENGL 100S or equivalent; and COS 61B; and READ 54 or READ 97 or equivalent with a grade of "C" or higher or "Pass" or a cosmetology license or proof of completion of a cosmetology program. NOTE: a material fee of \$600.00 is required for COS 55				
30117	8:00-10:05AM	MTW	Petrova,R	HS205
	10:05-4:35PM	MTW	Petrova,R	HS205
Class# 30117 meets 03/23/2020-05/22/2020				
COS 60A - 10.0 UNITS INTRODUCTORY COSMETOLOGY I Not Transferable Prerequisite: ENGL 100 or ENGL 100S or equivalent with a grade of "C" or higher or "Pass" and READ 54 or READ 97 or equivalent with a grade of "C" or higher or "Pass" or completion of the Reading placement process with eligibility for "Reading Exempt."				
22288	8:00-10:00AM	MTWThF	Smith,F	HS205
	10:00-4:20PM	MTWThF	Smith,F	HS205
Class# 22288 meets 01/13/2020-03/13/2020				
COS 60B - 10.0 UNITS INTRODUCTORY COSMETOLOGY II Not Transferable Prerequisite: COS 60A or COS 71A with a grade of "C" or higher or "Pass".				
22290	8:00-10:00AM	MTWThF	Smith,F	HS205
	10:00-3:50PM	MTWThF	Smith,F	HS205
Class# 22290 meets 03/23/2019-05/24/2019				
COS 61A - 10.0 UNITS INTERMEDIATE COSMETOLOGY I Not Transferable Prerequisite: COS 50C or 60B or 70A or 71B with a grade of "C" or higher or "Pass".				
22292	8:00-10:00AM	MTWThF	Motruk,N	HS204
	10:00-4:20PM	MTWThF	Motruk,N	HS204
Class# 22292 meets 01/13/2020-03/13/2020				

Students not in attendance or late for the first class meeting are subject to drop.

Class#	Time	Day	Instructor	Room	Class#	Time	Day	Instructor	Room
COS 61B - 10.0 UNITS INTERMEDIATE COSMETOLOGY II					COUN 200 - 3.0 UNITS SUCCESS IN COLLEGE AND CAREER				
Not Transferable					Transferable to UC, CSU				
Prerequisite: COS 61A or COS 72A with a grade of "C" or higher or "Pass".					Recommendation: Completion of ENGL 20 or equivalent with a grade of "C" or higher or "Pass" or completion of the English Placement Process with eligibility for ENGL 52, ENGL 72, and ESL 152.				
22294	8:00-10:00AM	MTWThF	Motruk,N	HS204	27093	9:30-10:45AM	TTh	Fisher,C	MP205
	10:00-3:50PM	MTWThF	Motruk,N	HS204	22271	5:00-7:50PM	T	Quilizapa,C	MP205
Class# 22294 meets 03/23/2019-05/24/2019					27866	9:30-10:45AM	MW	Aguayo,R	SL107
COS 62A - 10.0 UNITS ADVANCED COSMETOLOGY I					27095	1:00-2:15PM	TTh	Aslanyan,K EOPS	BE119
Not Transferable					22277	9:00-11:50AM	F	Walsh,M	MP205
Prerequisite: COS 51C or COS 61B or COS 70B or COS 72B with a grade of "C" or higher or "Pass".					27019	11:00-12:15PM	MW	Mahoney,M	MP205
22296	8:00-10:00AM	MTWThF	Motruk,N	HS204	22279	9:30-10:45AM	MW	Castro,R	MP205
	10:00-4:20PM	MTWThF	Motruk,N	HS204	25715	5:00-7:50PM	M	Bello,F	MP205
Class# 22296 meets 01/13/2020-03/13/2020					26147	2:00-4:50PM	M	Gallardo,B	MP205
COS 62B - 10.0 UNITS ADVANCED COSMETOLOGY II					28779	1:00-3:50PM	F	Carrillo,R	MP205
Not Transferable					29569	12:30-1:45PM	TTh	Wang,L	SS211
Prerequisite: COS 62A or COS 73A with a grade of "C" or higher or "Pass".					30119	3.0 HRS ARR	(OL)	Hurtado,H	ONLINE
22298	8:00-10:00AM	MTWThF	Motruk,N	HS204	30120	8:30-9:45AM	MW	STAFF	MC103
	10:00-3:50PM	MTWThF	Motruk,N	HS204	30121	8:30-9:45AM	TTh	STAFF	MCIS207
Class# 22298 meets 03/23/2019-05/24/2019					22276	12:00-1:35PM	TTh	Chew,H	LA104
COS 98 - 1.0 UNIT DIRECTED STUDIES					Class# 22276 meets 02/04/2020-05/21/2020				
Not Transferable					23156	6.0 HRS ARR	(OL)	Hoyle,S	ONLINE
29133	6.0 HRS ARR		Motruk,N	HS204	Class# 23156 meets 01/13/2020-03/13/2020				
Class# 29133 meets 01/13/2020-03/13/2020					29568	6.0 HRS ARR	(OL)	Gallardo,B	ONLINE
COS 99 - 2.0 UNITS DIRECTED STUDIES					Class# 29568 meets 01/13/2020-03/13/2020				
Not Transferable					29997	6.0 HRS ARR	(OL)	Hoyle,S	ONLINE
26803	12.0 HRS ARR		Motruk,N	HS204	Class# 29997 meets 03/23/2020-05/22/2020				
Class# 26803 meets 01/13/2020-03/13/2020					CULINARY ARTS				
29134	12.0 HRS ARR		Petrova,R	HS204	CA 55 - 1.0 UNIT FUNDAMENTALS OF RESPONSIBLE ALCOHOL SERVICE				
Class# 29134 meets 03/23/2019-05/24/2019					Not Transferable				

COUNSELING

COUN 10 - 1.0 UNIT CAREER PLANNING				
Not Transferable				
27348	1:00-2:50PM	M	Quilizapa,C	MC103
Class# 27348 meets 03/23/2020-05/18/2020				
26660	2:00-3:50PM	T	Lee,R	MP205
Class# 26660 meets 03/24/2020-05/19/2020				
COUN 101A - 0.5 UNIT ORIENTATION TO COLLEGE				
Transferable to CSU				
29566	9:30-10:45AM	W	Hernandez-Garcia,N	MC102
Class# 29566 meets 04/15/2020-05/20/2020				
COUN 101B - 0.5 UNIT EDUCATIONAL PLANNING				
Transferable to CSU				
29567	11:00-12:15PM	T	Valenzuela,R	EOPS AD117
Class# 29567 meets 01/14/2020-02/18/2020				
28745	11:00-12:15PM	T	Valenzuela,R	EOPS AD117
Class# 28745 meets 02/25/2020-04/07/2020				
25238	5:00-6:15PM	Th	Wang,L	MP205
Class# 25238 meets 02/27/2020-04/09/2020				
25237	11:00-12:15PM	T	Valenzuela,R	EOPS AD117
Class# 25237 meets 04/14/2020-05/19/2020				
COUN 101C - 1.0 UNIT NAVIGATING THE TRANSFER PROCESS				
Transferable to CSU				
29996	1:00-2:50PM	T	Franco Jr.,R	FA134
Class# 29996 meets 01/14/2020-03/10/2020				
27022	1:00-2:50PM	Th	Lundeen,B	MP103
Class# 27022 meets 03/26/2020-05/21/2020				
COUN 150 - 3.0 UNITS DYNAMICS OF LEADERSHIP				
Transferable to CSU				
Recommendation: Satisfactory completion of the English Placement Process or ENGL 52 or equivalent with a grade of "C" or higher or "Pass" and participation in a college or community-based organization or club.				
23158	12:30-1:45PM	TTh	Romero,G (PUENTE)	BC 47
26377	12:30-1:45PM	TTh	Hill,S	LA203

CA 55 - 1.0 UNIT FUNDAMENTALS OF RESPONSIBLE ALCOHOL SERVICE				
Not Transferable				
26379	2:00-3:50PM	T	Aiton,A	CB102
Class# 26379 meets 01/14/2020-03/10/2020				
CA 98 - 1.0 UNIT DIRECTED STUDIES				
Not Transferable				
29994	3.0 HRS ARR		Lopez,J	
CA 101 - 1.0 UNIT INTRODUCTION TO FOOD SERVICE, SAFETY, AND SANITATION				
Transferable to CSU				
21095	2:00-3:50PM	T	Yu,J	CB104
Class# 21095 meets 01/14/2020-03/10/2020				
21113	2:00-3:50PM	T	Yu,J	CB104
Class# 21113 meets 03/24/2020-05/19/2020				
CA 120 - 3.0 UNITS INTRODUCTION TO THE HOSPITALITY INDUSTRY				
Transferable to CSU				
25149	3:00-5:50PM	M	Lew,E	CB102
CA 180 - 4.0 UNITS INTRODUCTION TO BAKING SKILLS				
Transferable to CSU				
Corequisite: CA 101 or equivalent with a grade of "C" or higher or "Pass" or prior completion.				
20827	2:00-3:50PM	Th	Yu,J	CB104
PLEASE ENROLL IN LAB SECTION OF YOUR CHOICE. THE LECTURE SECTION #20827 WILL BE AUTOMATICALLY ADDED.				
21366	4:00-9:50PM	Th	Yu,J	CB104
25748	4:00-9:50PM	Th	Nicolas,E	CB103
CA 181 - 5.0 UNITS PROFESSIONAL BAKING AND PASTRY PRODUCTION I				
Transferable to CSU				
Prerequisite: CA 101 and CA 180 or equivalent with grades of "C" or higher or "Pass."				
20828	4:00-5:30PM	MW	Lopez,J	CB104
PLEASE ENROLL IN LAB SECTION OF YOUR CHOICE. THE LECTURE SECTION #20828 WILL BE AUTOMATICALLY ADDED.				
21367	5:30-8:45PM	MW	Lopez,J	CB104
26380	5:30-8:45PM	MW	Nicolas,E	CB103

Students not in attendance or late for the first class meeting are subject to drop.

Class#	Time	Day	Instructor	Room	Class#	Time	Day	Instructor	Room
CA 182 - 5.0 UNITS PROFESSIONAL BAKING AND PASTRY PRODUCTION II					22147 6.0 HRS ARR (OL) Hathaway,R ONLINE				
Transferable to CSU					Note: Online registered students must go to the Canvas class webpage for mandatory online orientation information.				
Prerequisite: CA 181 or equivalent with a grade of "C" or higher or "Pass."					Class# 22147 meets 01/13/2020-03/13/2020				
20829	4:00-5:30PM	MW	Aiton,A	CB101	28111	6.0 HRS ARR (OL)		Gregory,C	ONLINE
	5:30-8:45PM	MW	Aiton,A	CB101	Note: Online registered students must go to the Canvas class webpage for mandatory online orientation information.				
Class# 28111 meets 01/13/2020-03/13/2020					28112 6.0 HRS ARR (OL) Gregory,C ONLINE				
CA 230 - 3.0 UNITS PROFESSIONAL HEALTHY COOKING					Note: Online registered students must go to the Canvas class webpage for mandatory online orientation information.				
Transferable to CSU					Class# 28112 meets 01/13/2020-03/13/2020				
25156	2:00-4:50PM	T	Pierini,M	CB101	22831 6.0 HRS ARR (OL) Hathaway,R ONLINE				
CA 240 - 3.0 UNITS HUMAN RELATIONS IN HOSPITALITY					Note: Online registered students must go to the Canvas class webpage for mandatory online orientation information.				
Transferable to CSU					Class# 22831 meets 03/23/2020-05/22/2020				
Prerequisite: CA 120 or equivalent with a grade of "C" or higher or "Pass."					28259 6.0 HRS ARR (OL) Gregory,C ONLINE				
29995	5:00-7:50PM	T	STAFF	CB101	Note: Online registered students must go to the Canvas class webpage for mandatory online orientation information.				
CA 250 - 7.0 UNITS PROFESSIONAL COOKING I					Class# 28259 meets 03/23/2020-05/22/2020				
Transferable to CSU					28295 6.0 HRS ARR (OL) Gregory,C ONLINE				
Corequisite: CA 101 or prior completion or equivalent with a grade of "C" or higher or "Pass."					Note: Online registered students must go to the Canvas class webpage for mandatory online orientation information.				
Recommendation: Completion of ENGL 52, or ENGL 72, or ESL 152, or equivalent with a grade of "C" or higher or "Pass" or completion of the placement process with eligibility for ENGL 100.					Class# 28295 meets 03/23/2020-05/22/2020				
25150	10:00-12:00PM	TW	Lopez,J	CB104	29216 6.0 HRS ARR (OL) Hathaway,R ONLINE				
	12:00-1:50PM	M	Lopez,J	CB104	Note: Online registered students must go to the Canvas class webpage for mandatory online orientation information.				
	12:00-1:50PM	TW	Lopez,J	CB104	Class# 29216 meets 03/23/2020-05/22/2020				
CA 251 - 8.0 UNITS PROFESSIONAL COOKING II					DANC 101 - 3.0 UNITS HISTORY OF DANCE				
Transferable to CSU					Transferable to UC, CSU				
Prerequisite: CA 152 or CA 250 or equivalent with a grade of "C" or higher or "Pass" and CA 101 or equivalent with a grade of "C" or higher or "Pass."					22149 9:00-11:50AM F Hendrix,J K 201				
Recommendation: CA 230 or equivalent with a grade of "C" or higher or "Pass."					28150 3.0 HRS ARR (OL) Berney,D ONLINE				
25152	9:00-9:50AM	TWTh	Lew,E	CB102	30111 3:00-4:15PM TTh Wicks,K K202				
	9:00-1:15PM	M	Lew,E	CB102	DANC 102 - 2.0 UNITS INTRODUCTION TO ADAPTIVE DANCE				
	10:00-1:15PM	TWTh	Lew,E	CB102	Transferable to UC, CSU				
CA 252 - 8.0 UNITS PROFESSIONAL COOKING III					30112 12:30-2:20PM TTh Horner,B DS102				
Transferable to CSU					1:00-2:20PM TTh Horner,B DS102				
Prerequisite: CA 153 or CA 251 or equivalent with a grade of "C" or higher or "Pass."					DANC 105 - 3.0 UNITS INTRODUCTION TO DANCE MOVEMENT				
Recommendation: CA 230 or equivalent with a grade of "C" or higher or "Pass" and completion of ENGL 52, or ENGL 72, or ESL 152, or equivalent with a grade of "C" or higher or "Pass" or completion of the placement process with eligibility for ENGL 100.					Transferable to UC, CSU				
25154	9:00-9:50AM	TWTh	Pierini,M	CB101	22150 9:00-9:30AM TTh Ibarguen Allpas,V DS101				
	9:00-1:15PM	M	Pierini,M	CB101	9:30-11:20AM TTh Ibarguen Allpas,V DS101				
	10:00-1:15PM	TWTh	Pierini,M	CB101	DANC 106A - 2.0 UNITS BEGINNING BALLET				
CA 260 - 3.0 UNITS FOODS PURCHASE AND CONTROL					Transferable to UC, CSU				
Transferable to CSU					26131 6:30-7:00PM TTh Cole,P DS101				
20826	4:00-6:50PM	T	Lew,E	CB102	7:00-8:20PM TTh Cole,P DS101				
DANCE					28836 2:00-2:30PM MW Berney,D DS101				
DANC 50 - 1.0 UNIT INDIVIDUALIZED DANCE DEVELOPMENT					2:30-3:50PM MW Berney,D DS101				
Not Transferable					26657 10:00-11:10AM Sat Cole,P DS101				
28118	2:00-6:00PM	F	Gregory,C	DS101	11:10-2:40PM Sat Cole,P DS101				
DANC 100 - 3.0 UNITS DANCE APPRECIATION					Class# 26657 meets 01/18/2020-05/16/2020				
Transferable to UC, CSU					DANC 106B - 2.0 UNITS INTERMEDIATE BALLET				
DANCE CONCERT AUDITIONS					Transferable to UC, CSU				
Saturday, JANUARY 18th @ 10:30 a.m. in the Dance Studio Building (DS 101).					27023 2:00-2:30PM MW Berney,D DS101				
Dance Concert participants are required to enroll in DANC 150/151					2:30-3:50PM MW Berney,D DS101				
Concert Dates: To be announced					29069 6:30-7:00PM TTh Cole,P DS101				
(For more information contact Rebekah Hathaway, Ext.2846 or Email instructor at rathaway@cerritos.edu).					7:00-8:20PM TTh Cole,P DS101				
22227	12:30-1:45PM	TTh	Hathaway,R	K 201	22158 10:00-11:10AM Sat Cole,P DS101				
27221	3.0 HRS ARR (OL)		Berney,D	ONLINE	11:10-2:40PM Sat Cole,P DS101				
27266	10:00-11:15AM	MW	Roman-Rodriguez,D	K 201	Class# 22158 meets 01/18/2020-05/16/2020				
29254	9:30-10:45AM	TTh	Hendrix,J	K 201	DANC 107 - 2.0 UNITS BALLET VARIATIONS				
22148	6.0 HRS ARR (OL)		Hathaway,R	ONLINE	Transferable to UC, CSU				
Note: Online registered students must go to the Canvas class webpage for mandatory online orientation information.					28838 6:30-7:00PM TTh Cole,P DS101				
Class# 22148 meets 01/13/2020-03/13/2020					7:00-8:20PM TTh Cole,P DS101				
					29071 2:00-2:30PM MW Berney,D DS101				
					2:30-3:50PM MW Berney,D DS101				
					22160 10:00-11:10AM Sat Cole,P DS101				
					11:10-2:40PM Sat Cole,P DS101				
					Class# 22160 meets 01/18/2020-05/16/2020				
					DANC 108A - 2.0 UNITS DANCE, MODERN, BEGINNING				
					Transferable to UC, CSU				
22162	12:30-1:00PM	TTh	Wicks,K	DS101	22162 12:30-1:00PM TTh Wicks,K DS101				
	1:30-2:20PM	TTh	Wicks,K	DS101	28800 12:00-12:30PM MW Roman-Rodriguez,D DS101				
	12:00-12:30PM	MW	Roman-Rodriguez,D	DS101	12:30-1:50PM MW Roman-Rodriguez,D DS101				
	12:30-1:50PM	MW	Roman-Rodriguez,D	DS101					

Students not in attendance or late for the first class meeting are subject to drop.

Class#	Time	Day	Instructor	Room	Class#	Time	Day	Instructor	Room
DANC 108B - 2.0 UNITS DANCE, MODERN, INTERMEDIATE					DANC 136 - 2.0 UNITS DANCE REPERTORY				
Transferable to UC, CSU					Transferable to UC, CSU				
22166	12:30-1:00PM	TTh	Wicks,K	DS101	27947	4.0 HRS ARR		STAFF	
	1:30-2:20PM	TTh	Wicks,K	DS101		2:00- 4:00PM	F	Gregory,C	DS101
28802	12:00-12:30PM	MW	Roman-Rodriguez,D	DS101	DANC 140 - 2.0 UNITS BEGINNING JAZZ DANCE				
	12:30-1:50PM	MW	Roman-Rodriguez,D	DS101	Transferable to UC, CSU				
DANC 110 - 2.0 UNITS COMMERCIAL DANCE FOUNDATIONS					22183	10:00-10:30AM	MW	Cabag,V	DS101
Transferable to UC, CSU						10:30-11:50AM	MW	Cabag,V	DS101
22168	10:00-11:00AM	F	Cabag,V	DS101	DANC 141 - 2.0 UNITS INTERMEDIATE JAZZ DANCE				
	11:00-1:50PM	F	Cabag,V	DS101	Transferable to UC, CSU				
22216	9:00-9:30AM	TTh	Ibarguen Allpas,V	DS101	Prerequisite: TH 140 or DANC 140 or equivalent with a grade of "C" or higher or "Pass".				
	9:30-10:50AM	TTh	Ibarguen Allpas,V	DS101	22185	10:00-10:30AM	MW	Cabag,V	DS101
29719	4:00-4:30PM	MW	Jones,M	DS101		10:30-11:50AM	MW	Cabag,V	DS101
	4:30-5:50PM	MW	Jones,M	DS101	DANC 150 - 2.0 UNITS REHEARSAL FOR FORMAL DANCE CONCERTS				
DANC 112 - 2.0 UNITS CONTEMPORARY DANCE					Transferable to UC, CSU				
Transferable to UC, CSU					23171	1.0 HRS ARR		Gregory,C	DS101
28840	10:00-10:30AM	MW	Cabag,V	DS101		+ 3.0 HRS ARR		Gregory,C	DS101
	10:30-11:50AM	MW	Cabag,V	DS101	Mandatory first class meeting/audition on Saturday, JANUARY 18, at 10:30 in DS 101				
29721	4:00-4:30PM	MW	Jones,M	DS101	DANC 151 - 2.0 UNITS REHEARSAL FOR INFORMAL DANCE SHOWCASES				
	4:30-5:50PM	MW	Jones,M	DS101	Transferable to UC, CSU				
DANC 120 - 2.0 UNITS PARTNERING FOR DANCE					23173	1.0 HRS ARR		Hathaway,R	DS101
Transferable to UC, CSU						+ 3.0 HRS ARR		Hathaway,R	DS101
29723	4:30-5:00PM	TTh	Rosa,S	DS102	Mandatory first class meeting/audition on Saturday, JANUARY 18, at 10:30 in DS 101				
	5:00-6:20PM	TTh	Rosa,S	DS102	DANC 151 - 2.0 UNITS REHEARSAL FOR INFORMAL DANCE SHOWCASES				
DANC 121 - 2.0 UNITS LATIN SOCIAL DANCE					Transferable to UC, CSU				
Transferable to UC, CSU					23173	1.0 HRS ARR		Hathaway,R	DS101
22172	4:30-5:00PM	TTh	Rosa,S	DS101		+ 3.0 HRS ARR		Hathaway,R	DS101
	5:00-6:20PM	TTh	Rosa,S	DS101	Mandatory first class meeting/audition on Saturday, JANUARY 18, at 10:30 in DS 101				
27858	6:00-7:00PM	F	Cole,P	DS101	DANC 151 - 2.0 UNITS REHEARSAL FOR INFORMAL DANCE SHOWCASES				
	7:00-9:50PM	F	Cole,P	DS101	Transferable to UC, CSU				
DANC 122 - 2.0 UNITS MIDDLE EASTERN DANCE					23173	1.0 HRS ARR		Hathaway,R	DS101
Transferable to UC, CSU						+ 3.0 HRS ARR		Hathaway,R	DS101
30113	2:30-4:20PM	TTh	Rosa,S	DS102	Mandatory first class meeting/audition on Saturday, JANUARY 18, at 10:30 in DS 101				
DANC 123 - 2.0 UNITS AFRICAN DANCE					DANC 151 - 2.0 UNITS REHEARSAL FOR INFORMAL DANCE SHOWCASES				
Transferable to UC, CSU					Transferable to UC, CSU				
27088	6:00-6:30PM	MW	Jones,M	DS101	23173	1.0 HRS ARR		Hathaway,R	DS101
	6:30-7:50PM	MW	Jones,M	DS101		+ 3.0 HRS ARR		Hathaway,R	DS101
DANC 124 - 2.0 UNITS HIP HOP DANCE I					Mandatory first class meeting/audition on Saturday, JANUARY 18, at 10:30 in DS 101				
Transferable to UC, CSU					DANC 151 - 2.0 UNITS REHEARSAL FOR INFORMAL DANCE SHOWCASES				
22178	12:00-12:30PM	MW	Cabag,V	DS101	Transferable to UC, CSU				
	12:30-1:50PM	MW	Cabag,V	DS101	23173	1.0 HRS ARR		Hathaway,R	DS101
25321	10:00-11:00AM	F	Cabag,V	DS101		+ 3.0 HRS ARR		Hathaway,R	DS101
	11:00-1:50PM	F	Cabag,V	DS101	Mandatory first class meeting/audition on Saturday, JANUARY 18, at 10:30 in DS 101				
29725	4:30-5:00PM	TTh	Robertson,J	DS102	DANC 151 - 2.0 UNITS REHEARSAL FOR INFORMAL DANCE SHOWCASES				
	5:00-6:20PM	TTh	Robertson,J	DS102	Transferable to UC, CSU				
DANC 125 - 2.0 UNITS INTRODUCTION TO BALLROOM DANCE					23173	1.0 HRS ARR		Hathaway,R	DS101
Transferable to UC, CSU						+ 3.0 HRS ARR		Hathaway,R	DS101
29729	6:00-7:00PM	F	Cole,P	DS102	Mandatory first class meeting/audition on Saturday, JANUARY 18, at 10:30 in DS 101				
	7:00-8:50PM	F	Cole,P	DS102	DANC 151 - 2.0 UNITS REHEARSAL FOR INFORMAL DANCE SHOWCASES				
DANC 126 - 2.0 UNITS HIP HOP DANCE II					Transferable to UC, CSU				
Transferable to UC, CSU					23173	1.0 HRS ARR		Hathaway,R	DS101
27253	12:00-12:30PM	MW	Cabag,V	DS101		+ 3.0 HRS ARR		Hathaway,R	DS101
	12:30-1:50PM	MW	Cabag,V	DS101	Mandatory first class meeting/audition on Saturday, JANUARY 18, at 10:30 in DS 101				
29727	4:30-5:00PM	TTh	Robertson,J	DS101	DANC 151 - 2.0 UNITS REHEARSAL FOR INFORMAL DANCE SHOWCASES				
	5:00-6:20PM	TTh	Robertson,J	DS101	Transferable to UC, CSU				
DANC 130A - 2.0 UNITS BEGINNING CHOREOGRAPHY					23173	1.0 HRS ARR		Hathaway,R	DS101
Transferable to UC, CSU						+ 3.0 HRS ARR		Hathaway,R	DS101
28806	2:30-3:00PM	TTh	Robertson,J	DS101	Mandatory first class meeting/audition on Saturday, JANUARY 18, at 10:30 in DS 101				
	+ 3.0 HRS ARR		Gregory,C		DANC 151 - 2.0 UNITS REHEARSAL FOR INFORMAL DANCE SHOWCASES				
	3:00- 4:00PM	TTh	Robertson,J	DS101	Transferable to UC, CSU				
DANC 130B - 2.0 UNITS INTERMEDIATE CHOREOGRAPHY					23173	1.0 HRS ARR		Hathaway,R	DS101
Transferable to UC, CSU						+ 3.0 HRS ARR		Hathaway,R	DS101
28808	2:30-3:00PM	TTh	Robertson,J	DS101	Mandatory first class meeting/audition on Saturday, JANUARY 18, at 10:30 in DS 101				
	+ 3.0 HRS ARR		Gregory,C		DANC 151 - 2.0 UNITS REHEARSAL FOR INFORMAL DANCE SHOWCASES				
	3:00-4:00PM	TTh	Robertson,J	DS101	Transferable to UC, CSU				
DANC 135 - 2.0 UNITS DANCE WORKSHOP					23173	1.0 HRS ARR		Hathaway,R	DS101
Transferable to UC, CSU						+ 3.0 HRS ARR		Hathaway,R	DS101
27269	4.0 HRS ARR		Hathaway,R	DS101	Mandatory first class meeting/audition on Saturday, JANUARY 18, at 10:30 in DS 101				

DENTAL ASSISTING

Applications for Fall 2020 admission to the Dental Assisting Program are due in the Health Occupations Division Office no later than May 15, 2020. Students must be accepted into the Dental Assisting Program prior to enrolling in any class. For more information call (562) 860-2451, ext. 2550.

DA 61 - 3.0 UNITS APPLIED DENTAL SCIENCE II									
Not Transferable									
Prerequisite: DA 51 or equivalent with a grade of "C" or higher or "Pass".									
Corequisite: DA 63.									
20327	12:30-2:20PM	T	STAFF	HS305	PLEASE ENROLL IN LAB SECTION AS ASSIGNED. THE LECTURE SECTION #20327 WILL BE AUTOMATICALLY ADDED.				
20328	8:00-10:50AM	T	STAFF	LAB A	HS307				
20329	2:30-5:20PM	T	STAFF	LAB B	HS307				
28717	3:00-5:50PM	M	STAFF	LAB C	HS307				
DA 62 - 2.0 UNITS DENTAL RADIOGRAPHY II									
Not Transferable									
Prerequisite: DA 52 or equivalent with a grade of "C" or higher or "Pass".									
20330	11:00-11:50AM	F	Cosio,L	HS305	PLEASE ENROLL IN LAB SECTION AS ASSIGNED. THE LECTURE SECTION #20330 WILL BE AUTOMATICALLY ADDED.				
20331	8:00-10:50AM	Th	Cosio,L	LAB A	HS308				
20332	1:00-3:50PM	Th	Cosio,L	LAB B	HS308				
28718	2:30-5:20PM	T	Cosio,L	LAB C	HS308				
DA 63 - 4.0 UNITS ADVANCED CHAIRSIDE ASSISTING									
Not Transferable									
Prerequisite: DA 53 and DA 54 or equivalent with grades of Pass or "C" or higher. Corequisite: DA 65.									
20333	1:00-2:50PM	M	STAFF	HS305	PLEASE ENROLL IN LAB SECTION OF YOUR CHOICE. THE LECTURE SECTION #20333 WILL BE AUTOMATICALLY ADDED.				
20334	8:00-10:50AM	ThF	STAFF	LAB B	HS307				
20335	1:30-4:20PM	ThF	STAFF	LAB A	HS307				
DA 64 - 2.0 UNITS DENTAL OFFICE MANAGEMENT									
Not Transferable									
Prerequisite: DA 51 or equivalent with a grade of "C" or higher or "Pass".									
20336	8:00-9:00AM	M	STAFF	SL110					
	9:00-11:50AM	M	STAFF	SL110					

Students not in attendance or late for the first class meeting are subject to drop.

Class#	Time	Day	Instructor	Room	Class#	Time	Day	Instructor	Room
DA 65 - 3.0 UNITS CLINICAL I DENTAL SCHOOLS Not Transferable Prerequisite: DA 53, DA 54 or equivalent with grades of Pass or "C" or higher. Corequisite: DA 61, 62, and 63.									
20338	12:00-12:50PM 8:00-2:50PM	F W	Cosio,L Cosio,L	HS307 USC *					
DENTAL HYGIENE									
Applications for Fall 2020 admission to the Dental Hygiene Program are due in the Health Occupations Division Office no later than April 1, 2020. Students must be accepted into the Dental Hygiene Program prior to enrolling in any class. For more information call (562) 860-2451, ext. 2550. Clearance of a criminal background check and/or drugs of abuse testing may be required prior to clinical field experience.									
DH 120 - 2.0 UNITS PREVENTIVE DENTISTRY II Transferable to CSU Prerequisite: DH 114 or equivalent with a grade of "C" or higher or "Pass". Corequisite: DH 125C. Recommendation: DH 110 or equivalent with a grade of "C" or higher or "Pass".									
20339	1:00-2:50PM	Th	Brabender,M	HS104					
DH 125 - 2.0 UNITS DENTAL HYGIENE CLINICAL SCIENCES II Transferable to CSU Prerequisite: DH 114 and DH 115C or equivalent with a grade of "C" or higher or "Pass". Corequisite: DH 125C.									
20340	8:00-10:00AM 10:00-10:50AM	T T	Loera,D Loera,D	HS303 HS303					
DH 125C - 3.0 UNITS CLINICAL DENTAL HYGIENE II Transferable to CSU Prerequisite: DH 115C or equivalent with a grade of "C" or higher or "Pass". Corequisite: DH 125.									
20341	8:30-11:20AM 8:30-11:20AM 1:00-3:50PM	F M F	Grammatica,A Nguyen,A Grammatica,A	LAB A	HDSN* RYBL* HDSN*				
20342	8:30-11:20AM 1:00-3:50PM 1:00-3:50PM	F F M	DiPietro-Fife,D DiPietro-Fife,D Nguyen,A	LAB B	LBVA* LBVA* RYBL*				
20343	8:30-11:20AM 8:30-11:20AM 1:00-3:50PM	M F M	DiPietro-Fife,D Loera,D DiPietro-Fife,D	LAB C	ELMT* LBVA* ELMT*				
20344	8:30-11:20AM 1:00-3:50PM 1:00-3:50PM	M M F	Grammatica,A Grammatica,A Loera,D	LAB D	HDSN* HDSN* LBVA*				
23288	8:30-11:20AM 8:30-11:20AM 1:00-3:50PM	M F M	Loera,D Loera,D Segovia,E Loera,D	LAB E	LBVA* LBVA* RYBL* LBVA*				
DH 126 - 2.0 UNITS GENERAL AND ORAL PATHOLOGY Transferable to CSU Prerequisite: DH 112, DH 116, and DH 119 or equivalent with grades of Pass or "C" or higher. Corequisite: DH 125C.									
20345	1:00-2:00PM 2:00-3:50PM	T T	Shore,M Shore,M	HS103 HS103					
DH 127 - 2.0 UNITS PHARMACOLOGY Transferable to CSU Prerequisite: DH 115C, DH 116, and DH 119 or equivalent with grades of Pass or "C" or higher. Corequisite: DH 125C and DH 128.									
20346	8:00-9:50AM	Th	Rozak,T	SL106					
DH 128 - 2.0 UNITS MANAGEMENT OF PAIN Transferable to CSU Prerequisite: DH 116 with a grade of "C" or higher or "Pass". Corequisite: DH 125 and DH 127.									
20347	8:00-8:50AM	W	Carroll,D	LBVA*					
PLEASE ENROLL IN LAB SECTION OF YOUR CHOICE. THE LECTURE SECTION #20347 WILL BE AUTOMATICALLY ADDED.									
20348	9:00-11:50AM	W	Krayer,A	LBVA*					
20349	1:00-3:50PM	W	Krayer,A	LBVA*					
DH 129 - 2.0 UNITS APPLIED PERIODONTICS Transferable to CSU Prerequisite: DH 114 or equivalent with a grade of "C" or higher or "Pass". Corequisite: DH 125C.									
20350	10:00-11:50AM	Th	Rozak,T	SL106					
DH 244 - 2.0 UNITS ETHICAL ISSUES IN DENTAL HYGIENE Transferable to CSU Prerequisite: DH 235C or equivalent with a grade of "C" or higher or "Pass". Corequisite: DH 245C.									
20351	3:00-4:50PM	T	Krayer,A	HS104					
DH 245 - 2.0 UNITS DENTAL HYGIENE CLINICAL SCIENCES IV Transferable to CSU Prerequisite: DH 235C or equivalent with a grade of "C" or higher or "Pass". Corequisite: DH 245C.									
20352	8:00-8:50AM 2:00-2:50PM 1:00-1:50PM	T T T	Carroll,D Loera,D Loera,D	SL106 HS303 HS303					
DH 245C - 4.0 UNITS CLINICAL DENTAL HYGIENE IV Transferable to CSU Prerequisite: DH 235C or equivalent with a grade of "C" or higher or "Pass". Corequisite: DH 245.									
20353	8:30-11:20AM 8:30-11:20AM 1:00-3:50PM 1:00-3:50PM	F M F M	Shore,M Krayer,A Shore,M Krayer,A	LAB A	CDCL* RYBL* CDCL* RYBL*				
20354	8:30-11:20AM 8:30-11:20AM 1:00-3:50PM 1:00-3:50PM	W F W F	Loera,D Carroll,D Loera,D Carroll,D	LAB B	MLK* RYBL* MLK* RYBL*				
20355	8:30-11:20AM 8:30-11:20AM 1:00-3:50PM 1:00-3:50PM	M W M W	Carroll,D Shore,M Carroll,D Shore,M	LAB C	LBHC* RYBL* LBHC* RYBL*				
20356	8:30-11:20AM 8:30-11:20AM 1:00-3:50PM 1:00-3:50PM	W M W M	Nguyen,A Shore,M Nguyen,A Shore,M	LAB D	HDSN* USC* HDSN* USC*				
23289	8:30-11:20AM 8:30-11:20AM 1:00-3:50PM 1:00-3:50PM	W M W M	Benson,M Benson,M Benson,M Benson,M		ELMT* HMPH* ELMT* HMPH*				
DH 248 - 1.0 UNIT COMMUNITY OUTREACH II Transferable to CSU Prerequisite: DH 238 or equivalent with a grade of "C" or higher or "Pass".									
21893	9:00-10:00AM 10:00-10:50AM	Th Th	Brabender,M Brabender,M	HS104 HS104					
21895	3:00-4:00PM 4:00-4:50PM	Th Th	Brabender,M Brabender,M	HS104 HS104					
DH 249 - 2.0 UNITS PRINCIPLES OF COMMUNITY ORAL HEALTH Transferable to CSU									
20357	9:00-10:50AM	T	Carroll,D	SL106					
EARTH SCIENCE									
ESCI 104 - 3.0 UNITS OCEANOGRAPHY Transferable to UC, CSU Recommendation: ENGL 52 or ENGL 72 or ESL 152 or equivalent with a grade of "C" or higher or "Pass" or completion of the English placement process with a score eligible for ENGL 100, and MATH 40 or equivalent with a grade of "C" or higher or "Pass" or completion of the math placement process with a score eligible for MATH 60.									
20404	12:30-3:20PM	T	DeKraker,D(Honors Section)	PST137					
20875	3.0 HRS ARR	(OL)	DeKraker,D	ONLINE					
Orientation: All class information will be available online via Canvas. Email address: ddekraker@cerritos.edu									
28253	3.0 HRS ARR	(OL)	DeKraker,D	ONLINE					
Orientation: All class information will be available online via Canvas. Email address: ddekraker@cerritos.edu									
28716	8:00-9:15AM	MW	Iwaz,N	PST143					

Students not in attendance or late for the first class meeting are subject to drop.

Class#	Time	Day	Instructor	Room	Class#	Time	Day	Instructor	Room
ESCI 104L - 1.0 UNIT OCEANOGRAPHY LABORATORY					23709 6:00-9:00PM M Namala,S SS306				
Transferable to UC, CSU					9:00-9:50PM M Namala,S SS306				
Prerequisite: ESCI 104 or equivalent with a grade of "C" or higher or "Pass" or concurrent enrollment.					27299 3.0 HRS ARR (OL) STAFF ONLINE				
Recommendation: ENGL 52 or ENGL 72 or ESL 152 or equivalent with a grade of "C" or higher or "Pass" or completion of the English placement process with a score eligible for ENGL 100, and MATH 40 or equivalent with a grade of "C" or higher or "Pass" or completion of the math placement process with a score eligible for MATH 60.					+ 1.0 HRS ARR (OL) STAFF ONLINE				
22202	12:30-3:20PM	Th	DeKraker,D	PST137	23339	3:00-4:30PM TTh	STAFF		SS306
ESCI 106 - 3.0 UNITS WEATHER AND CLIMATE					4:30- 5:20PM TTh STAFF SS306				
Transferable to UC, CSU					Class# 23339 meets 01/14/2020-05/07/2020				
Recommendation: ENGL 52 or ENGL 72 or ESL 152 or equivalent with a grade of "C" or higher or "Pass" or completion of the English placement process with a score eligible for ENGL 100, and MATH 40 or equivalent with a grade of "C" or higher or "Pass" or completion of the math placement process with a score eligible for MATH 60.					27309 11:00-2:00PM MW Namala,S SS306				
29669	3.0 HRS ARR (OL)		DeKraker,D	ONLINE	2:00-2:55PM MW Namala,S SS306				
Orientation: All class information will be available online via Canvas. Email address: ddekraker@cerritos.edu					Class# 27309 meets 01/13/2020-03/11/2020				
ESCI 110 - 4.0 UNITS INTRODUCTION TO EARTH SCIENCE					ECON 201M - 3.0 UNITS PRINCIPLES OF MACROECONOMICS				
Transferable to UC, CSU					Transferable to UC, CSU				
Recommendation: ENGL 52 or ENGL 72 or ESL 152 or equivalent with a grade of "C" or higher or "Pass" or completion of the English placement process with a score eligible for ENGL 100, and MATH 40 or equivalent with a grade of "C" or higher or "Pass" or completion of the math placement process with a score eligible for MATH 60.					Prerequisite: MATH 60 or equivalent with a grade of "C" or higher or "Pass" or completion of the assessment/placement process with eligibility for MATH 80 or MATH 80A or higher.				
20405	9:30-11:00AM MW		DeKraker,D	PST137	Recommendation: ENGL 100 or equivalent with a grade of "C" or higher or "Pass."				
	11:00-12:15PM MW		DeKraker,D	PST137	22443	11:00-12:30PM TTh	STAFF		SS306
20407	12:30-2:00PM MW		Okbamichael,M	PST137		12:30-12:50PM TTh	STAFF		SS306
	2:00-3:15PM MW		Okbamichael,M	PST137	22577	8:00-9:30AM TTh	STAFF		SS307
22510	4:00-5:30PM MW		Berekian,B	PST143		9:30-9:50AM TTh	STAFF		SS307
23652	5:30-6:45PM MW		Berekian,B	PST143	22871	6:00-9:00PM M	Namala,S		SS306
	7:00-8:30PM TTh		Clifford,H	PST137		9:00-9:50PM M	Namala,S		SS306
	8:30-9:45PM TTh		Clifford,H	PST137	23567	3.0 HRS ARR (OL)	STAFF		ONLINE
ESCI 180 - 1.0 UNIT EARTH SCIENCE MATERIALS AND PREPARATIONS					+ 1.0 HRS ARR (OL) STAFF ONLINE				
Transferable to CSU					28041 3.0 HRS ARR (OL) STAFF ONLINE				
Prerequisite: ESCI 110, or GEOL 101, or GEOG 101, or GEOG 101L with a grade of "C" or higher or "Pass."					+ 1.0 HRS ARR (OL) STAFF ONLINE				
22573	3.0 HRS ARR		DeKraker,D		27301	3.0 HRS ARR (OL)	STAFF		ONLINE
27071	3.0 HRS ARR		Lo Vetere,C		+ 1.0 HRS ARR (OL)	STAFF			ONLINE
ECONOMICS					23341 3:00-4:30PM TTh STAFF SS306				
ECON 101 - 3.0 UNITS ECONOMIC ISSUES AND POLICY					4:30-5:20PM TTh STAFF SS306				
Transferable to UC, CSU					Class# 23341 meets 01/14/2020-05/07/2020				
25685	3.0 HRS ARR (OL)		STAFF	ONLINE	22587	11:00-2:00PM MW	Namala,S		SS306
Online orientation via Canvas is to be completed during the first week of the course. Four on campus visits required.					2:00-2:40PM MW Namala,S SS306				
22300	9:00-10:35AM MW		Namala,S	SS306	Class# 22587 meets 01/13/2020-03/11/2020				
					Orientation will be conducted online. Instructor will email instructions to enrolled students the first day of class.				
27292	7:00-10:20PM W		STAFF	SS306	23569	6:00-9:00PM M	STAFF		SS307
						9:00-9:50PM M	STAFF		SS307
26394	9:30-11:00AM Th		STAFF	SS138	27334	6:00-9:00PM Th	STAFF		SS306
						9:00-9:50PM Th	STAFF		SS306
Class# 26394 meets 02/06/2020-05/21/2020					28589 3.0 HRS ARR (OL) STAFF ONLINE				
ECON 201 - 3.0 UNITS PRINCIPLES OF MACROECONOMICS					+ 1.0 HRS ARR (OL) STAFF ONLINE				
Transferable to UC, CSU (CAN ECON 2)					Orientation will be conducted online. Instructor will email instructions to enrolled students the first day of class.				
Prerequisite: MATH 40 or equivalent with a grade of "C" or higher or "Pass" or completion of the Math Placement Process with a score eligible for MATH 60.					27729 11:00-2:00PM MW Namala,S SS306				
Recommendation: ENGL 100 or equivalent with a grade of "C" or higher or "Pass".					2:00-2:40PM MW Namala,S SS306				
22130	11:00-12:30PM TTh		STAFF	SS306	Class# 27729 meets 03/23/2020-05/20/2020				
	12:30-12:50PM TTh		STAFF	SS306	ECON 202 - 3.0 UNITS PRINCIPLES OF MICROECONOMICS				
22131	8:00-9:30AM TTh		STAFF	SS307	Transferable to UC, CSU				
	9:30-9:50AM TTh		STAFF	SS307	Prerequisite: MATH 40 or equivalent with a grade of "C" or higher or "Pass" or completion of the assessment/placement process with eligibility for MATH 80 or MATH 80A or higher.				
28039	3.0 HRS ARR (OL)		STAFF	ONLINE	Recommendation: ENGL 100 or equivalent with a grade of "C" or higher or "Pass".				
	+ 1.0 HRS ARR (OL)		STAFF	ONLINE	22445	9:00-10:30AM MW	STAFF		SS137
Orientation will be conducted online. Instructor will email instructions to enrolled students the first day of class.					22446	10:30-10:50AM MW	STAFF		SS137
23565	3.0 HRS ARR (OL)		STAFF	ONLINE	22937	2:30-2:50PM TTh	STAFF		SS306
	+ 1.0 HRS ARR (OL)		STAFF	ONLINE	22447	1:00-2:30PM TTh	STAFF		SS306
Orientation will be conducted online. Instructor will email instructions to enrolled students the first day of class.					3.0 HRS ARR (OL) STAFF ONLINE				
					+ 1.0 HRS ARR (OL) STAFF ONLINE				
					Orientation will be conducted online. Instructor will email instructions to enrolled students the first day of class.				

Students not in attendance or late for the first class meeting are subject to drop.

Class#	Time	Day	Instructor	Room	Class#	Time	Day	Instructor	Room
ENGR 240 - 3.0 UNITS DYNAMICS Transferable to UC, CSU Prerequisite: ENGR 235 or equivalent with a grade of "C" or higher or "Pass".									
29682	7:00-9:50PM	T	STAFF	S 104					
ENGR 245 - 3.0 UNITS STRENGTH OF MATERIALS Transferable to UC, CSU Prerequisite: ENGR 235 or equivalent with a grade of "C" or higher or "Pass".									
29993	7:00-9:50PM	Th	STAFF	S 104					

ENGINEERING DESIGN TECHNOLOGY

ENGT 103 - 3.0 UNITS INTRODUCTION TO ENGINEERING DESIGN USING INVENTOR Transferable to CSU Please read the technical standards relevant to this department at https://www.cerritos.edu/technology/standards.htm .				
26299	4:00-5:00PM	MW	Jamka,A	PST230
	5:00-6:20PM	MW	Jamka,A	PST230

ENGT 116 - 2.0 UNITS BLUEPRINT READING Transferable to CSU Recommendation: ENGT 131 or equivalent with a grade of "C" or higher or "Pass".				
28961	6:00-7:30PM	F	Li,D	PST227
	7:30-8:50PM	F	Li,D	PST227
28963	1.5 HRS ARR	(OL)	Li,D	ONLINE
	+ 1.5 HRS ARR	(OL)	Li,D	ONLINE

ENGT 117 - 2.0 UNITS GEOMETRICAL DIMENSIONING AND TOLERANCING Transferable to CSU Corequisite: ENGT 116 or equivalent with a grade of "C" or higher or "Pass" or prior completion.				
27926	4.0 HRS ARR	(OL)	Real,Y	ONLINE
Class# 27926 meets 01/13/2020-03/13/2020				

ENGT 131 - 3.0 UNITS DESIGN FUNDAMENTALS INCLUDING 3D MODELING Transferable to CSU Recommendation: ENGT 116 or equivalent with a grade of "C" or higher, or "Pass".				
20403	8:00-9:00AM	MW	Li,D	PST227
	9:00-10:50AM	MW	Li,D	PST227

ENGT 137 - 4.0 UNITS INDUSTRIAL DESIGN AND 3D MODELLING IN FUSION360 Transferable to CSU				
30002	6:00-7:30PM	TTh	Micic,M	PST224
	7:30-8:50PM	TTh	Micic,M	PST224

ENGT 237 - 3.0 UNITS STATICS AND STRENGTH OF MATERIALS USING SIMULATION Transferable to CSU				
28756	2.0 HRS ARR	(OL)	Micic,M	ONLINE
	+ 4.0 HRS ARR	(OL)	Micic,M	ONLINE

ENGT 259 - 4.0 UNITS SOLIDWORKS INTRODUCTION Transferable to CSU				
26955	3.0 HRS ARR	(OL)	Micic,M	ONLINE
	+ 3.0 HRS ARR	(OL)	Micic,M	ONLINE

ENGT 263 - 4.0 UNITS SOLIDWORKS FOR INDUSTRIAL MOLD TOOLS DESIGN Transferable to CSU Prerequisite: ENGT 259 or equivalent with a grade of "C" or higher, or "Pass."				
29604	8:00-11:22AM	Sat	Li,D	PST227
	11:52-3:00PM	Sat	Li,D	PST227
Class# 29604 meets 01/18/2020-05/16/2020				

ENGINEERING TECHNOLOGY

ET 101 - 3.0 UNITS PRINCIPLES OF ENGINEERING TECHNOLOGY Transferable to CSU Please read the technical standards relevant to this department at https://www.cerritos.edu/technology/standards.htm .				
22926	8:00-10:15AM	Sat	Jamka,A	ME 2
	10:15-1:20PM	Sat	Jamka,A	ME 2
Class# 22926 meets 01/18/2020-05/16/2020				
ET 105 - 2.0 UNITS INDUSTRIAL MOTOR CONTROL Transferable to CSU				
29606	5:30-8:20PM	W	Real,Y	ME 2
Class# 29606 meets 01/15/2020-04/08/2020				

ENGLISH

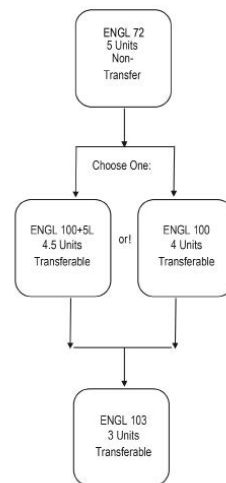

English 100, Freshman Composition, is required for transfer and for A.A. degrees. The English writing classes above help you to achieve those goals.

If you previously placed in English 20, English 72 is now the place to start. Students who were placed in English 52 or who passed English 20 with a C or better may take English 100+5L. This class adds a lab component to the Freshman Composition class to provide extra support for students as they complete their transfer requirement.

Both English 100+5L and English 100 complete the transfer and A.A. degree requirement; students need only take one of those courses. Students whose transfer goals require a critical thinking class may take English 103 after they pass Freshman Composition successfully.

ENGL 100 - 4.0 UNITS FRESHMAN COMPOSITION Transferable to UC, CSU (CAN ENGL 2)				
20365	7:00-8:50AM	MW	Juntilla,T	(Honors Section) LA104
20366	8:00-9:50AM	MW	STAFF	LA213
20368	8:00-9:50AM	MW	STAFF	LA211
28216	9:00-10:50AM	MW	Quaas-Berryman,F	LA205
20370	9:00-10:50AM	MW	Fagundes,M	SS141
20371	11:00-12:50PM	MW	Sartin,N	LA203
23386	1:00-2:50PM	MW	STAFF	LA210
22605	1:00-2:50PM	MW	STAFF	LC218
20373	11:00-12:50PM	TTh	STAFF	LA201
20374	11:00-12:50PM	MW	Quaas-Berryman,F	LA209
20375	4.0 HRS ARR	(OL)	Gaik,F	ONLINE
Mandatory Orientation: Will be held on Canvas which must be completed no later than 11:55 pm on 01/13/20 to remain enrolled in the class.				
20376	9:00-10:50AM	TTh	Gaik,F	LA204
20377	3:00-4:50PM	MW	STAFF	LA201
22628	9:00-12:50PM	F	STAFF	LA106
22606	11:00-12:50PM	MW	Shah,N	LA105
20378	4.0 HRS ARR	(OL)	STAFF	ONLINE
Mandatory Orientation: Will be held on Canvas which must be completed no later than 11:55 pm on 01/13/20 to remain enrolled in the class.				

Students not in attendance or late for the first class meeting are subject to drop.

Class#	Time	Day	Instructor	Room	Class#	Time	Day	Instructor	Room
20379	7:00-8:50PM	MW	STAFF	LA109	30146	7:00-8:50PM	TTh	STAFF	LC217
25813	4.0 HRS ARR	(OL)	Gaik,F	ONLINE	20390	4.8 HRS ARR	(OL)	STAFF	ONLINE
Mandatory Orientation: Will be held on Canvas which must be completed no later than 11:55 pm on 01/13/20 to remain enrolled in the class.					Mandatory orientation on FRIDAY 1/31/2020 from 10:00AM-12:00PM in LA103. Class# 20390 meets 02/03/2020-05/22/2020				
22630	3:00-4:50PM	TTh	STAFF	LA202	23746	4.8 HRS ARR	(OL)	STAFF	ONLINE
20380	4.0 HRS ARR	(OL)	Quaas-Berryman,F	ONLINE	Mandatory Orientation: The orientation for this class will be online. The instructor will contact students prior to the start of the semester with instructions.				
Mandatory Orientation: Will be held on Canvas which must be completed no later than 11:55 pm on 01/13/20 to remain enrolled in the class.					Class# 23746 meets 02/03/2020-05/22/2020				
20381	11:00-12:50PM	W	Gardner,D (HYBRID)	LA106	29208	4.8 HRS ARR	(OL)	STAFF	ONLINE
*A PORTION OF THE HOURS FOR THIS CLASS WILL BE ONLINE					Mandatory Orientation: The instructor will email enrolled students before the start of the semester.				
20382	9:00-12:50PM	F	STAFF	LA201	Class# 29208 meets 02/03/2020-05/22/2020				
26462	7:00-8:50AM	TTh	Sartin,N	LA203	29209	4.8 HRS ARR	(OL)	STAFF	ONLINE
20383	1:00-2:50PM	TTh	Olague,M	LA109	Mandatory Orientation: Instructor will email enrolled students before the start of the semester.				
20386	8.0 HRS ARR	(OL)	Gonzales,J	ONLINE	Class# 29209 meets 02/03/2020-05/22/2020				
Class# 20386 meets 01/13/2020-03/13/2020					26735	9:00-1:15PM	Sat	STAFF	LA202
Mandatory Orientation: Will be held on Canvas which must be completed no later than 11:55 pm on 01/13/20 to remain enrolled in the class.					Class# 26735 meets 01/18/2020-05/16/2020				
23798	8.0 HRS ARR	(OL)	Gonzales,J	ONLINE	28997	9:00-1:15PM	Sat	STAFF	LA201
Class# 23798 meets 03/23/2020-05/22/2020					Class# 28997 meets 01/18/2020-05/16/2020				
Mandatory Orientation: You must complete the online orientation that is located on Canvas to remain enrolled in this course.					20369	8.0 HRS ARR	(OL)	Kait,K	ONLINE
20387	4.0 HRS ARR	(OL)	Shah,N	ONLINE	Mandatory Orientation: Instructor will contact students prior to the start of the class with orientation Instructions.				
Mandatory Orientation: You must complete the online orientation that is located on Canvas to remain enrolled in this course.					Class# 20369 meets 01/13/2020-03/13/2020				
20388	4.0 HRS ARR	(OL)	Shah,N	ONLINE	29119	8.0 HRS ARR	(OL)	STAFF	ONLINE
Mandatory Orientation: Enrolled students will be contact by the instructors before the first day of class.					Mandatory Orientation: Instructor will contact students prior to the start of the class with orientation Instructions.				
23799	7:00-8:50PM	MW	STAFF	LA106	Class# 29119 meets 01/13/2020-03/13/2020				
26464	5:00-6:50PM	MW	STAFF	LA203	28280	8.0 HRS ARR	(OL)	Kait,K	ONLINE
25831	9:00-10:50AM	MW	Juntilla,T (Honors Section)	LA104	Class# 28280 meets 03/23/2019-05/24/2019				
23800	4:00-5:50PM	TTh	STAFF	LA205	Mandatory Orientation: Instructor will contact students prior the start of the class with orientation Instructions.				
20863	9:00-12:50PM	F	STAFF	LA202	28885	7:00-10:50AM	MW	Cheatham,T	LA203
20864	11:00-12:50PM	M	Gardner,D (HYBRID)	LA106	Class# 28885 meets 01/13/2020-03/11/2020				
*A PORTION OF THE HOURS FOR THIS CLASS WILL BE ONLINE					22569	7:00-10:50AM	TTh	Cheatham,T	LA211
20866	7:00-8:50PM	TTh	STAFF	LA106	Class# 22569 meets 01/14/2020-03/12/2020				
22933	7:00-8:50PM	TTh	STAFF	LA209	28996	7:00-10:50AM	MW	Cheatham,T	LA203
23740	4.0 HRS ARR	(OL)	Kayser,L	ONLINE	Class# 28996 meets 03/23/2020-05/20/2020				
Mandatory Orientation: Enrolled students will be contact by the instructors before the first day of class.					ENGL 100S - 4.5 UNITS ENHANCED FRESHMAN COMPOSITION				
25762	1:00-2:50PM	TTh	Fagundes,M	LA105	Transferable to UC, CSU				
23741	4.0 HRS ARR	(OL)	Kayser,L	ONLINE	Prerequisite: ENGL 52 or ENGL 72 or ESL 152 or equivalent with a grade of "C" or higher or "Pass" or completion of the current English placement process with eligibility for ENGL 52 or ENGL72.				
Mandatory Orientation: Enrolled students will be contact by the instructors before the first day of class.					29778	11:00-12:50PM	M	Lovejoy-Robold,N	(HYBRID) LA201
22454	4.0 HRS ARR	(OL)	Cole,E	ONLINE	Note: A portion of this class will be online.				
Mandatory Orientation: Will be held on Canvas which must be completed no later than 11:55 pm on 01/13/20 to remain enrolled in the class.					29780	11:00-12:50PM	W	Lovejoy-Robold,N	(HYBRID) LA201
21910	4.0 HRS ARR	(OL)	Cole,E	ONLINE	Note: A portion of this class will be online.				
Mandatory Orientation: Enrolled students will be contact by the instructors before the first day of class.					29786	1:00-2:50PM	M	STAFF	(HYBRID) LA202
22231	4.0 HRS ARR	(OL)	Mitchell-Lambert,J	ONLINE	Note: A portion of this class will be online.				
Mandatory Orientation: Will be held on Canvas which must be completed no later than 11:55 pm on 01/13/20 to remain enrolled in the class.					29788	3:00-3:50PM	M	STAFF	(HYBRID) LA202
22332	3:00-4:35PM	TThF	STAFF	WARR*	Note: A portion of this class will be online.				
This class will be held at Warren High School 8141 De Palma St. Downey 90241.					29788	1:00-2:50PM	W	STAFF	(HYBRID) LA202
22360	7:00-8:50AM	TTh	Gaik,F	LA202	Note: A portion of this class will be online.				
28058	9:00-10:50AM	MW	STAFF	LM20*	29794	1:00-2:50PM	T	Clifford,S	(HYBRID) LA202
This class is being held at our satellite campus. La Mirada Center, 15310 Alondra Blvd., La Mirada, 90638 in classroom #20.					3:00-3:50PM T Clifford,S (HYBRID) LA104				
22810	4.0 HRS ARR	(OL)	Mitchell-Lambert,J	ONLINE	Note: A portion of this class will be online.				
Mandatory Orientation: Enrolled students will be contact by the instructors before the first day of class.					29796	1:00-2:50PM	Th	Clifford,S	(HYBRID) LA202
28019	9:00-10:50AM	TTh	Fagundes,M	LA205	Note: A portion of this class will be online.				
26795	9:00-10:50AM	TTh	Sartin,N	LA110	29797	3:00-3:50PM	Th	Clifford,S	(HYBRID) LA104
28146	1:00-2:50PM	MW	Shah,N	LC213	29802	8:00-9:50AM	MW	Alvarez,L	LA201
28886	2:00-3:50PM	TTh	STAFF	LA203	29803	10:00-10:50AM	MW	Alvarez,L	LA201
28887	4.0 HRS ARR	(OL)	Cagnolatti,D	ONLINE	29804	8:00-9:50AM	MW	STAFF	LA202
Mandatory Orientation: Enrolled students will be contact by the instructors before the first day of class.					10:00-10:50AM MW STAFF LA202				
28888	5:00-6:50PM	MW	STAFF	LA204	29812	11:00-12:50PM	MW	Alvarez,L	MC102
28889	7:00-8:50PM	MW	STAFF	LA211	1:00-1:50PM MW Alvarez,L MC102				
28995	11:00-12:50PM	TTh	STAFF	LA106	29814	11:00-12:50PM	MW	Olague,M	MCIS209
29204	7:00-8:50AM	TTh	Gardner,D	LA204	1:00-1:50PM MW Olague,M MCIS209				
29210	9:00-10:50AM	MW	STAFF	SS213	29816	11:00-12:50PM	MW	Danielo,J	PST236
30142	9:00-10:50AM	MW	STAFF	SS316	1:00-1:50PM MW Danielo,J PST236				
30143	8:00-9:50AM	TTh	STAFF	SS316	29818	1:00-2:50PM	MW	Cagnolatti,D	SS308
30144	9:00-10:50AM	TTh	STAFF	LA105	3:00-3:50PM MW Cagnolatti,D SS308				
30145	9:00-10:50AM	TTh	STAFF	LA103	29822	5:00-6:50PM	MW	STAFF	LA201
					7:00-7:50PM MW STAFF LA201				
					29824 4:00-5:50PM MW STAFF LA202				
					6:00-6:50PM MW STAFF LA202				

Students not in attendance or late for the first class meeting are subject to drop.

Class#	Time	Day	Instructor	Room	Class#	Time	Day	Instructor	Room
29826	7:00-8:50PM	MW	STAFF	LA202	30148	8:00-9:15AM	MW	STAFF	SS138
	9:00-9:50PM	MW	STAFF	LA202	20868	8:00-9:15AM	MW	Gardner,D (Honors Section)	LC218
29828	7:00-8:50PM	MW	STAFF	LA203	23389	3:00-4:15PM	MW	STAFF	LA204
29829	9:00-9:50PM	MW	STAFF	LA203	26466	7:00-9:50PM	Th	STAFF	LA205
29830	7:00-8:50PM	MW	STAFF	LA204	23390	5:00-6:15PM	MW	STAFF	LA205
	9:00-9:50PM	MW	STAFF	LA204	21528	7:00-9:50PM	T	STAFF	LA205
29834	8:00-9:50AM	TTh	Alvarez,L	LA201	23391	7:00-9:50PM	T	STAFF	LA213
	10:00-10:50AM	TTh	Alvarez,L	LA201	23392	7:00-9:50PM	Th	STAFF	LA213
29846	1:00-2:50PM	TTh	STAFF	LA205	30149	9:00-10:15AM	MW	STAFF	LA105
	3:00-3:50PM	TTh	STAFF	LA205	21667	1:00-2:15PM	MW	STAFF	LA105
29848	1:00-2:50PM	TTh	Cole,E	MC104	30150	3:00-4:15PM	MW	STAFF	LA213
	3:00-3:50PM	TTh	Cole,E	MC104	27346	3.0 HRS ARR	(OL)	STAFF	ONLINE
29850	4:00-5:50PM	TTh	STAFF	LA203	Mandatory Orientation: Enrolled students will be contact by the instructors before the first day of class.				
	6:00-6:50PM	TTh	STAFF	LA203	23900	7:00-9:50PM	W	STAFF	LA205
29852	4:00-5:50PM	TTh	STAFF	LA201	26775	3.0 HRS ARR	(OL)	STAFF	ONLINE
	6:00-6:50PM	TTh	STAFF	LA201	Mandatory Orientation: Enrolled students will be contact by the instructors before the first day of class.				
29854	5:00-6:50PM	TTh	STAFF	LA202	26797	9:00-11:50AM	F	STAFF	LA203
	7:00-7:50PM	TTh	STAFF	LA202	22225	9:00-11:50AM	F	STAFF	LA204
29856	7:00-8:50PM	TTh	STAFF	LA201	26798	9:00-11:50AM	F	STAFF	LA205
	9:00-9:50PM	TTh	STAFF	LA201	30151	7:00-8:15PM	MW	STAFF	LA212
29858	7:00-8:50PM	TTh	STAFF	LA203	26805	7:00-9:50PM	W	STAFF	LA213
	9:00-9:50PM	TTh	STAFF	LA203	30152	10:00-11:15AM	TTh	STAFF	SS307
29860	7:00-8:50PM	TTh	STAFF	LA204	27427	7:00-9:50PM	M	STAFF	LA205
	9:00-9:50PM	TTh	STAFF	LA204	27428	9:30-10:45AM	TTh	STAFF	MC103
29782	11:00-12:50PM	M	Hua,L (HYBRID)	LA205	27429	7:00-8:15PM	TTh	STAFF	LA211
	1:00-1:50PM	M	Hua,L (HYBRID)	LA205	27431	1:00-2:15PM	MW	STAFF	MP209
Note: A portion of this class will be online.					27432	11:00-12:15PM	TTh	STAFF	LA202
Class# 29782 meets 02/03/2020-05/18/2020					28018	9:00-10:15AM	MW	Mitchell-Lambert,J	BE106
29790	8:00-9:50AM	T	Serwin,L (HYBRID)	LA106	30153	11:00-12:15PM	TTh	STAFF	LA110
	10:00-10:50AM	T	Serwin,L (HYBRID)	LA106	28173	3.0 HRS ARR	(OL)	STAFF	ONLINE
Note: A portion of this class will be online.					Mandatory Orientation: Enrolled students will be contact by the instructors before the first day of class.				
Class# 29790 meets 02/04/2020-05/19/2020					28555	3.0 HRS ARR	(OL)	STAFF	ONLINE
29798	1:00-2:50PM	T	Hua,L (HYBRID)	LA201	Mandatory Orientation: Enrolled students will be contact by the instructors before the first day of class.				
	3:00-3:50PM	T	Hua,L (HYBRID)	LA201	28556	3.0 HRS ARR	(OL)	STAFF	ONLINE
Note: A portion of this class will be online.					Mandatory Orientation: Enrolled students will be contact by the instructors before the first day of class.				
Class# 29798 meets 02/04/2020-05/19/2020					29009	8:00-9:15AM	TTh	STAFF	LA210
29784	11:00-12:50PM	W	Serwin,L (HYBRID)	LA205	29010	11:00-12:15PM	TTh	STAFF	LA205
	1:00-1:50PM	W	Serwin,L (HYBRID)	LA205	29011	9:00-10:15AM	TTh	Quaas-Berryman,F (PUENTE)	MCIS211
Note: A portion of this class will be online.					29012	11:00-12:15PM	TTh	STAFF	LA204
Class# 29784 meets 02/05/2020-05/20/2020					29013	9:00-10:15AM	MW	STAFF	BE110
29792	8:00-9:50AM	Th	Serwin,L (HYBRID)	LA106	29014	10:30-11:45AM	MW	Mitchell-Lambert,J	BE106
	10:00-10:50AM	Th	Serwin,L (HYBRID)	LA106	29016	12:30-1:45PM	MW	STAFF	BE105
Note: A portion of this class will be online.					29018	12:30-1:45PM	MW	STAFF	BE119
Class# 29792 meets 02/06/2020-05/21/2020					29020	1:00-2:15PM	MW	STAFF	LM34*
29800	1:00-2:50PM	Th	Hua,L (HYBRID)	LA201	This class is being held at our satellite campus. La Mirada Center, 15310 Alondra Blvd., La Mirada, 90638 in classroom #34.				
	3:00-3:50PM	Th	Hua,L (HYBRID)	LA201	29021	3:00-4:15PM	TTh	STAFF	LA204
Note: A portion of this class will be online.					29022	4:30-5:45PM	TTh	STAFF	LA204
Class# 29800 meets 02/06/2020-05/21/2020					29864	7:00-9:50PM	M	STAFF	LA213
ENGL 102 - 3.0 UNITS INTRODUCTION TO LITERATURE					25308	3.6 HRS ARR	(OL)	STAFF	ONLINE
Transferable to UC, CSU (CAN ENGL 4)					Mandatory Orientation: Enrolled students will be contact by the instructors before the first day of class.				
Prerequisite: ENGL 100 or equivalent with a grade of "C" or higher or "Pass."					Class# 25308 meets 01/13/2020-05/01/2020				
20391	9:30-10:45AM	TTh	Mitchell-Lambert,J	LA209	28260	3.6 HRS ARR	(OL)	STAFF	ONLINE
20392	9:30-10:45AM	MW	Kalt,K	MP209	Mandatory Orientation: Enrolled students will be contact by the instructors before the first day of class.				
20867	11:00-12:15PM	MW	Kalt,K	LA211	Class# 28260 meets 02/03/2020-05/22/2020				
21527	1:00-2:15PM	MW	Mitchell-Lambert,J	LC217	28261	3.6 HRS ARR	(OL)	STAFF	ONLINE
30147	9:30-11:00AM	TTh	Kayser,L	MP211	Mandatory Orientation: Enrolled students will be contact by the instructors before the first day of class.				
Class# 30147 meets 02/04/2020-05/21/2020					Class# 28261 meets 02/03/2020-05/22/2020				
ENGL 103 - 3.0 UNITS CRITICAL AND ARGUMENTATIVE WRITING					28890	3.6 HRS ARR	(OL)	STAFF	ONLINE
Transferable to UC, CSU					Mandatory Orientation: Enrolled students will be contact by the instructors before the first day of class.				
Prerequisite: ENGL 100 or equivalent with a grade of "C" or higher or "Pass" or satisfactory completion of the Advanced Placement English Examination of the College Entrance Examination Board.					Class# 28890 meets 02/03/2020-05/22/2020				
21530	3.0 HRS ARR	(OL)	Cagnolatti,D	ONLINE	21650	9:30-11:00AM	TTh	STAFF	LA210
Mandatory Orientation: Enrolled students will be contact by the instructors before the first day of class.					Class# 21650 meets 02/04/2020-05/21/2020				
20395	11:00-12:15PM	TTh	STAFF	LA203	20398	9:00-12:05PM	Sat	STAFF	LA204
20396	11:00-12:15PM	MW	STAFF	SS316	Class# 20398 meets 01/18/2020-05/16/2020				
26773	3.0 HRS ARR	Cagnolatti,D(OL)	ONLINE	Mandatory Orientation: Enrolled students will be contact by the instructors before the first day of class.					
Mandatory Orientation: Enrolled students will be contact by the instructors before the first day of class.					29005	9:00-12:05PM	Sat	STAFF	LA205
23393	11:00-12:15PM	MW	STAFF	LC134	Class# 29005 meets 01/18/2020-05/16/2020				
23394	9:30-10:45AM	TTh	Lovejoy-Robold,N	BE117	29205	7:00-9:50PM	MW	STAFF	LA210
26774	1:00-2:15PM	TTh	STAFF	LA106	Class# 29205 meets 03/23/2020-05/20/2020				
23803	1:00-2:15PM	TTh	Quaas-Berryman,F	MP209	29865	7:00-9:50AM	TTh	Cheatham,T	LA211
28063	7:00-8:15PM	TTh	STAFF	LA210	Class# 29865 meets 03/24/2020-05/21/2020				
23804	3.0 HRS ARR	(OL)	STAFF	ONLINE					
Enrolled students will be contact by the instructors before the first day of class.									
23805	2:00-3:15PM	MW	STAFF	LA205					

Students not in attendance or late for the first class meeting are subject to drop.

Class#	Time	Day	Instructor	Room	Class#	Time	Day	Instructor	Room
ENGL 106 - 3.0 UNITS INTRODUCTION TO LINGUISTICS Transferable to UC, CSU 28557 9:30-10:45AM TTh Greene,C LA202					ENGL 246B - 3.0 UNITS SURVEY OF ENGLISH LITERATURE B: ROMANTICS TO THE PRESENT Transferable to UC, CSU (CAN ENGL 10) Prerequisite: Completion of English 100 or equivalent with a grade of "C" or "Pass," or completion of the English Placement Process. 20402 11:00-12:30PM MW Clifford,S LA202 Class# 20402 meets 02/03/2020-05/20/2020				
ENGL 110 - 4.0 UNITS CRITICAL THINKING THROUGH LITERATURE Transferable to UC, CSU Prerequisite: Completion of ENGL 100 or equivalent with a grade of "C" or higher or "Pass." 29866 9:00-10:50AM MW Gonzales,J LA204 29867 11:00-12:50PM MW Gonzales,J LA204 29868 1:00-2:50PM MW Clifford,S LA204 29869 4.8 HRS ARR (OL) Lovejoy-Robold,N ONLINE Class# 29869 meets 02/03/2020-05/22/2020					ENGL 248B - 3.0 UNITS MASTERPIECES OF WORLD LITERATURE Transferable to UC, CSU Prerequisite: Completion of ENGL 52, or ENGL 72 or ESL 152 or equivalent with a grade of "C" or higher, or "Pass," or completion of the English Placement Process with eligibility for ENGL 100. 28562 3:00-4:15PM MW Olague,M LA110				
ENGL 223 - 3.0 UNITS CHICANA/CHICANO LITERATURE Transferable to UC, CSU Prerequisite: Completion of ENGL 52, or ENGL 72 or ESL 152 or equivalent with a grade of "C" or higher, or "Pass," or completion of the English Placement Process with eligibility for ENGL 100. 28558 12:30-1:45PM TTh Alvarez,L LA204					ENGL 250 - 3.0 UNITS ADVANCED CREATIVE PORTFOLIO Transferable to CSU Prerequisite: ENGL 240, ENGL 241 OR FILM 241 with a grade of "C" or higher or of "Pass". 27099 1:00-2:15PM MW Danielo,J LA203				
ENGL 226 - 3.0 UNITS AFRICAN-AMERICAN LITERATURE Transferable to UC, CSU Prerequisite: Completion of ENGL 52, or ENGL 72 or ESL 152 or equivalent with a grade of "C" or higher, or "Pass," or completion of the English Placement Process with eligibility for ENGL 100. 28559 1:00-2:30PM MW Sartin,N LA106 Class# 28559 meets 02/03/2020-05/20/2020					<div style="background-color: #008080; color: white; text-align: center; padding: 5px;">ENGLISH AS A SECOND LANGUAGE</div> <p style="text-align: center;">CREDIT ESL COURSE SEQUENCE</p> <pre> graph TD E100[ENGLISH 100: Freshman Composition] --> E152[ESL 152: (5 Units) Introduction to College Composition for Non-Native English Speakers] E152 --> E120[ESL 120: (5 Units) Preparation for College Writing for Non-Native English Speakers] E120 --> E5[ESL 5: (formerly ESL 200) (4 Units) ESL Grammar, Reading, Writing 5] E5 --> E4[ESL 4: (formerly ESL 100) (4 Units) ESL Grammar, Reading, Writing 4] E4 --> E3[ESL 3: (5 Units) ESL Grammar, Reading, Writing 3] </pre> <p style="font-size: small;">ESL CORE COURSES ESL core classes emphasize grammar, reading, and writing. Our core courses prepare non-native English students who plan to get a certificate, AA degree, or take college-level courses. Students need to take the ESL Accuplacer test in the Assessment Center. Placement in a core course is based on the score of the assessment test. The Accuplacer test for native speakers of English may NOT be substituted for placement in ESL core courses.</p>				
ENGL 227 - 3.0 UNITS MODERN AND CONTEMPORARY LITERATURE Transferable to UC, CSU Prerequisite: Completion of ENGL 52, or ENGL 72, or ESL 152, or equivalent with a grade of "C" or higher, or "Pass," or completion of the English Placement Process with eligibility for ENGL 100. 28560 3.0 HRS ARR (OL) Gardner,D ONLINE Mandatory Orientation: Enrolled students will be contact by the instructors before the first day of class.									
ENGL 230B - 3.0 UNITS INTRODUCTION TO AMERICAN LITERATURE Transferable to UC, CSU (CAN ENGL 16) Prerequisite: Completion of ENGL 52, or ENGL 72 or ESL 152 or equivalent with a grade of "C" or higher, or "Pass," or completion of the English Placement Process with eligibility for ENGL 100. 28561 9:30-10:45AM TTh Kalt,K LA203									
ENGL 232 - 3.0 UNITS READINGS IN POETRY Transferable to UC, CSU (CAN ENGL 20) Prerequisite: Completion of ENGL 52, or ENGL 72 or ESL 152 or equivalent with a grade of "C" or higher, or "Pass," or completion of the English Placement Process with eligibility for ENGL 100. 27760 4:00-5:15PM TTh Olague,M LA106									
ENGL 235 - 3.0 UNITS READINGS IN THE DRAMA Transferable to UC, CSU (CAN ENGL 22) Prerequisite: Completion of ENGL 52, or ENGL 72 or ESL 152 or equivalent with a grade of "C" or higher, or "Pass," or completion of the English Placement Process with eligibility for ENGL 100. 21665 3:00-4:30PM MW Cole,E LA106 Class# 21665 meets 02/03/2020-05/20/2020									
ENGL 239 - 3.0 UNITS LITERATURE OF INDIA Transferable to UC, CSU Prerequisite: Completion of ENGL 52, ENGL 72, ESL 152 or equivalent with a grade of "C" or higher or "Pass," or completion of the English Placement Process with eligibility for ENGL 100. 29870 3.6 HRS ARR (OL) STAFF ONLINE Mandatory Orientation: Enrolled students will be contact by the instructors before the first day of class. Class# 29870 meets 02/03/2020-05/22/2020									
ENGL 240 - 3.0 UNITS CREATIVE WRITING Transferable to UC, CSU (CAN ENGL 6) Prerequisite: ENGL 52 or ENGL 72 or ESL 152 or equivalent with a grade of "C" or higher, or of "Pass," or completion of the English placement process with eligibility for ENGL 100. 27098 2:30-3:45PM TTh Greene,C LA106									
ENGL 242 - 3.0 UNITS WRITING POETRY Transferable to UC, CSU Prerequisite: ENGL 240 or equivalent with a grade of 'C' or higher, or 'Pass'. 29871 5:00-6:15PM MW Danielo,J LA106									

Students not in attendance or late for the first class meeting are subject to drop.

Class#	Time	Day	Instructor	Room	Class#	Time	Day	Instructor	Room
ESL 5 - 4.0 UNITS ESL GRAMMAR, READING, AND WRITING 5 Not Transferable Prerequisite: ESL 4 with a grade of "C" or higher or "Pass" or equivalent or AED 42.18 or equivalent (non-credit Adult Ed. ESL) with a grade of "Pass" or satisfactory completion of the assessment/placement process with eligibility for ESL 5.					25875 7:00-9:50PM TTh Mcllroy,L (HYBRID) LA110 + 1.2 HRS ARR Mcllroy,L LC205 LAB IS 1.2 HOURS PER WEEK IN THE SUCCESS CENTER, A PORTION OF THE HOURS FOR THIS CLASS WILL BE ONLINE. Class# 25875 meets 02/04/2020-05/21/2020				
29137	6:00-8:00PM	MW	Sugihara-Cheetham,J	DAS *	27289	11:00-2:05PM	MWF	Mcllroy,L	LA110
	8:00-8:30PM	MW	Sugihara-Cheetham,J	DAS *				Mcllroy,L	LC205
Note: This class will be held at the Downey Adult School: 12340 Woodruff Ave. Downey, 90241.					LAB IS 2.0 HOURS PER WEEK IN THE SUCCESS CENTER Class# 27289 meets 03/23/2020-05/22/2020				
23407	11:00-12:50PM	TTh	STAFF	LA109					
	+ 1.2 HRS ARR		STAFF	LC205					
LAB IS 1.2 HOURS PER WEEK IN THE SUCCESS CENTER Class# 23407 meets 02/04/2020-05/21/2020					FILM 101 - 3.0 UNITS MOTION PICTURE PRODUCTION Transferable to CSU				
ESL 10 - 3.0 UNITS ESL SPEAKING AND LISTENING 1 Not Transferable					22529 12:00-2:00PM M Hirohama,S (HYBRID) FA136 2:00-3:50PM M Hirohama,S (HYBRID) FA139				
29875	6:00-9:30PM	F	STAFF	LA109	30123	5:00-7:00PM	W	Turowski,K	FA136
Class# 29875 meets 02/07/2020-05/22/2020						7:00-10:50PM	W	Turowski,K	FA139
ESL 11 - 1.5 UNITS ESL READING 1 Not Transferable					27893 10:00-12:00PM W Turowski,K FA136 12:00-4:00PM W Turowski,K FA139				
26891	3.0 HRS ARR	(OL)	Berry,P	ONLINE	FILM 102 - 3.0 UNITS TELEVISION PRODUCTION Transferable to CSU				
All class information will be available online via Canvas. Class# 26891 meets 01/13/2020-03/13/2020					29080 10:00-12:00PM F Karshmer,A FA6 12:00-3:50PM F Karshmer,A FA9				
ESL 20 - 3.0 UNITS ESL SPEAKING AND LISTENING 2 Not Transferable					FILM 103 - 3.0 UNITS TELEVISION COMMERCIAL AND PUBLIC SERVICE ANNOUNCEMENT PRODUCE Transferable to CSU				
29876	6:00-9:30PM	F	STAFF	LA109	Prerequisite: FILM 101 or FILM 102 or equivalent with a grade of "C" or higher or "Pass"				
Class# 29876 meets 02/07/2020-05/22/2020					28726 10:00-12:00PM F Karshmer,A FA6 12:00-3:50PM F Karshmer,A FA9				
28563	12:30-2:00PM	MW	Sugihara-Cheetham,J	LA109	28791 5:00-7:00PM M Hirohama,S FA136 7:00-10:50PM M Hirohama,S FA139				
Class# 28563 meets 02/03/2020-05/20/2020					FILM 104 - 3.0 UNITS MOTION PICTURE AND DIGITAL CINEMATOGRAPHY Transferable to CSU				
ESL 21A - 3.0 UNITS ESL INTERMEDIATE VOCABULARY Not Transferable					Prerequisite: FILM 101 or equivalent with a grade of "C" or higher or "Pass"				
30074	3.6 HRS ARR	(OL)	Berry,P	ONLINE	27341	6:00-7:00PM	TTh	Hirohama,S	FA136
All class information will be available online via Canvas. Class# 30074 meets 02/03/2020-05/22/2020						7:00-8:50PM	TTh	Hirohama,S	FA139
ESL 31 - 1.5 UNITS ESL READING 2 Not Transferable					27895 10:00-12:00PM Sat Parrish,D FA136 12:00-4:45PM Sat Parrish,D FA139				
26757	3.0 HRS ARR	(OL)	Berry,P	ONLINE	Class# 27895 meets 01/18/2020-05/16/2020				
All class information will be available online via Canvas. Class# 26757 meets 03/23/2019-05/24/2019					FILM 160 - 3.0 UNITS GREAT FILM DIRECTORS Transferable to UC, CSU				
ESL 57 - 3.0 UNITS TOEFL PREPARATION COURSE Not Transferable					22535 6:00-9:20PM W Campolo,R FA133 9:20-10:20PM W Campolo,R FA134				
25844	3.6 HRS ARR	(OL)	Berry,P	ONLINE	Class# 22535 meets 02/05/2020-05/20/2020				
All class information will be available online via Canvas. Class# 25844 meets 02/03/2020-05/22/2020					FILM 241 - 3.0 UNITS SCREENWRITING Transferable to UC, CSU				
ESL 120 - 5.0 UNITS PREPARATION FOR COLLEGE WRITING FOR NON-NATIVE ENGLISH SPEAK Transferable to UC, CSU					Prerequisite: Completion of ENGL 52, ENGL 72, ESL 152 or equivalent with a grade of "C" or higher or "Pass", or completion of the English Placement Process with eligibility for ENGL 100.				
23419	8:00-10:50AM	TTh	STAFF	LA109	22537 3:00-5:50PM F Campolo,R (HYBRID) BC 47 Class# 22537 meets 02/07/2020-05/22/2020				
	+ 1.0 HRS ARR		STAFF	LC205	FILM 256 - 3.0 UNITS DOCUMENTARY FILM AND REALITY TELEVISION PRODUCTION Transferable to CSU				
LAB IS ONE HOUR PER WEEK IN THE SUCCESS CENTER					Prerequisite: FILM 101 and FILM 102 or equivalent with grades of Pass or "C" or higher.				
23421	7:00-9:50PM	TTh	STAFF	LA109	30125 9:00-10:00AM TTh Karshmer,A FA6 10:00-12:00PM TTh Karshmer,A FA9				
	+ 1.2 HRS ARR		STAFF	LC205	FILM 271 - 3.0 UNITS MUSIC VIDEO PRODUCTION Transferable to CSU				
LAB IS 1.2 HOURS PER WEEK IN THE SUCCESS CENTER Class# 23421 meets 02/04/2020-05/21/2020					Prerequisite: FILM 101, FILM 107, and FILM 102 or ART 114 courses or equivalents must be completed with grades of "C" or higher or "Pass". Recommendation: Adequate hearing and vision to produce and edit music videos.				
27287	11:00-2:25PM	MWF	Mcllroy,L	LA110	28793 5:00-7:00PM M Hirohama,S FA136 7:00-10:50PM M Hirohama,S FA139				
	+ 2.0 HRS ARR		Mcllroy,L	LC205					
LAB IS 2.0 HOURS PER WEEK IN THE SUCCESS CENTER Class# 27287 meets 01/13/2020-03/13/2020									
ESL 152 - 5.0 UNITS INTRODUCTION TO COLLEGE COMPOSITION FOR NON-NATIVE ENGLISH S Transferable to UC, CSU									
Prerequisite: Completion of the English as a Second Language placement process with a qualifying score for ESL 152 or completion of ESL 120 or equivalent with a grade of "C" or higher or "Pass".									
23423	12:30-3:00PM	TTh	Mcllroy,L	LA110					
	+ 1.0 HRS ARR		Mcllroy,L	LC205					
LAB IS ONE HOUR PER WEEK IN THE SUCCESS CENTER									

Students not in attendance or late for the first class meeting are subject to drop.

Class#	Time	Day	Instructor	Room	Class#	Time	Day	Instructor	Room
FILM 294 - 3.0 UNITS ADVANCED MOTION PICTURE PRODUCTION Transferable to CSU Prerequisite: FILM 101, FILM 104, and FILM 107 or equivalents with a grade of "C" or higher or "Pass"					FREN 202 - 4.0 UNITS INTERMEDIATE FRENCH Transferable to UC, CSU (CAN FREN 10) Prerequisite: FREN 201 or equivalent with a grade of "C" or higher or "Pass".				
27899	6:00-7:00PM	TTh	Hirohama,S	FA136	20414	11:00-12:50PM	MW	Florescu,M	LA213
	7:00-8:50PM	TTh	Hirohama,S	FA139	FREN 203 - 4.0 UNITS INTERMEDIATE FRENCH ADVANCED LEVEL I Transferable to UC, CSU Prerequisite: FREN 202 or equivalent with a grade of "C" or higher or "Pass".				

FINANCE

FIN 51 - 1.5 UNITS RETIREMENT PLANNING AND INVESTING Not Transferable				
22062	7:00-9:50PM	T	Wang,C	(HYBRID) BE122
Note: Class will meet the first day and the instructor will inform the students of future class meetings. Class# 22062 meets 01/14/2020-03/10/2020				
FIN 125 - 3.0 UNITS PERSONAL FINANCE Transferable to CSU				
22059	3.0 HRS ARR	(OL)	Moloney,P	ONLINE
Note: Orientation and all class work done online. Email instructor at pmoloney@cerritos.edu				
23470	3.0 HRS ARR	(OL)	Moloney,P	ONLINE
Note: Orientation and all class work done online. Email instructor at pmoloney@cerritos.edu				
22060	3.6 HRS ARR	(OL)	Aeryn,T	ONLINE
Note: Orientation and all class work done online. Email instructor at talenikov@cerritos.edu Class# 22060 meets 02/03/2020-05/22/2020				
28084	3.6 HRS ARR	(OL)	Farina,M	ONLINE
Note: All class information will be available at www.cerritos.edu/mfarina Class# 28084 meets 02/03/2020-05/22/2020				
23471	3.6 HRS ARR	(OL)	Korniakov,A	ONLINE
For class information and orientation, visit the Canvas website Class# 23471 meets 02/03/2020-05/18/2020				
FIN 126 - 3.0 UNITS INTRODUCTION TO STOCK MARKET AND INVESTMENTS Transferable to CSU				
22061	7:00-9:50PM	W	Wang,C	SS140

FRENCH

FREN 101 - 5.0 UNITS ELEMENTARY FRENCH Transferable to UC, CSU (CAN FREN 2)				
20411	8:30-10:45AM	MW	Florescu,M	LC213
+ 1.0 HRS ARR Florescu,M LC205 LAB IS ONE HOUR PER WEEK IN THE SUCCESS CENTER				
20879	12:30-2:45PM	TTh	Florescu,M	LA213
+ 1.0 HRS ARR Florescu,M LC205 LAB IS ONE HOUR PER WEEK IN THE SUCCESS CENTER				
28571	6:00-8:15PM	MW	Nicolas,J	LC213
+ 1.0 HRS ARR Nicolas,J LC205 LAB IS ONE HOUR PER WEEK IN THE SUCCESS CENTER				
29879	7:00-9:15PM	TTh	Nicolas,J	LC213
+ 1.0 HRS ARR Nicolas,J LC205 LAB IS ONE HOUR PER WEEK IN THE SUCCESS CENTER				
FREN 102 - 5.0 UNITS ELEMENTARY FRENCH Transferable to UC, CSU (CAN FREN 4) Prerequisite: FREN 101 or equivalent with a grade of "C" or higher or "Pass".				
20412	8:30-10:45AM	TTh	Florescu,M	LA213
+ 1.0 HRS ARR Florescu,M LC205 LAB IS ONE HOUR PER WEEK IN THE SUCCESS CENTER				
FREN 201 - 5.0 UNITS INTERMEDIATE FRENCH Transferable to UC, CSU (CAN FREN 8) Prerequisite: FREN 102 or equivalent with a grade of "C" or higher or "Pass".				
20413	11:00-1:15PM	MW	Florescu,M	LA213
+ 1.0 HRS ARR Florescu,M LC205 LAB IS ONE HOUR PER WEEK IN THE SUCCESS CENTER				

GEOGRAPHY

GEOG 101 - 3.0 UNITS PHYSICAL GEOGRAPHY Transferable to UC, CSU (CAN GEOG 2)				
26341	8:00-9:15AM	MW	Surfas,L	S 101
20417	9:30-10:45AM	MW	Surfas,L	S 101
20880	7:00-9:50PM	F	Conley,J	S 101
20882	11:00-12:15PM	TTh	Barajas,D	S 101
27130	4:00-6:50PM	W	Lo Vetere,C	S01
21546	12:30-1:45PM	TTh	Lo Vetere,C	S01
26924	2:00-3:15PM	TTh	Lo Vetere,C	S01
28708	6:00-9:30PM	M	Conley,J	S 101
Class# 28708 meets 02/03/2020-05/18/2020				
GEOG 101L - 1.0 UNIT PHYSICAL GEOGRAPHY LABORATORY Transferable to UC, CSU Prerequisite: GEOG 101 or equivalent with a grade of "C" or higher or "Pass" or concurrent enrollment.				
21826	10:00-12:50PM	F	Lo Vetere,C	S01
One Friday through Sunday camping field trip and up to two Saturday or Sunday field trips are a required part of this course. The dates of the field trips will be announced at the first class meeting.				
21827	1:00-3:50PM	F	Lo Vetere,C	S01
One Friday through Sunday camping field trip and up to two Saturday or Sunday field trips are a required part of this course. The dates of the field trips will be announced at the first class meeting.				
27801	4:00-6:50PM	T	Lo Vetere,C	S01
Note: Up to two Saturday or Sunday Field trips are a required of this course. Dates will be announced at the first class meeting.				
GEOG 102 - 3.0 UNITS CULTURAL GEOGRAPHY Transferable to UC, CSU (CAN GEOG 4)				
27802	2:00-3:15PM	MW	Goode,R	S 101
28712	6.0 HRS ARR	(OL)	Goode,R	ONLINE
Orientation: All class information will be available online via Canvas. Email address: rgoode@cerritos.edu Class# 28712 meets 01/13/2020-03/13/2020				
GEOG 103 - 3.0 UNITS ENVIRONMENTAL GEOGRAPHY Transferable to UC, CSU				
26925	2:00-3:15PM	TTh	Barajas,D	S 201
GEOG 105 - 3.0 UNITS WORLD REGIONAL GEOGRAPHY Transferable to UC, CSU				
20418	11:00-12:15PM	MW	Goode,R	S 101
23651	9:30-10:45AM	TTh	Goode,R	S 101
28226	6.0 HRS ARR	(OL)	Goode,R	ONLINE
Orientation: All class information will be available online via Canvas. Email address: rgoode@cerritos.edu Class# 28226 meets 03/23/2019-05/24/2019				
GEOG 298 - 1.0 UNIT DIRECTED STUDIES Transferable to CSU				
26842	3.0 HRS ARR		Lo Vetere,C	
29192	3.6 HRS ARR		Goode,R	
Class# 29192 meets 02/03/2020-05/22/2020				

Class#	Time	Day	Instructor	Room	Class#	Time	Day	Instructor	Room
--------	------	-----	------------	------	--------	------	-----	------------	------

GEOLOGY

GEOL 101 - 4.0 UNITS PHYSICAL GEOLOGY

Transferable to UC, CSU (CAN GEOL 2)
Prerequisite: ENGL 52 or ENGL 72 or ESL 152 or equivalent with a grade of "C" or higher or "Pass" or completion of the English placement process with a score eligible for ENGL 100.

Recommendation: MATH 40 or equivalent with a grade of "C" or higher or "Pass," or completion of the math placement process with a score eligible for MATH 60.

23012 1:00-2:30PM TTh Lacy,T PST143
2:30-3:45PM TTh Lacy,T PST143

Three one day Friday or Saturday or Sunday field trips (8:00am-5:00pm) are a required part of this course. Dates will be given the first day of class.

22238 12:30-2:00PM MW Lacy,T PST143
2:00-3:15PM MW Lacy,T PST143

Three one day Friday or Saturday or Sunday field trips (8:00am-5:00pm) are a required part of this course. Dates will be given the first day of class.

29670 9:30-11:00AM MW lwaz,N PST143
11:00-12:15PM MW lwaz,N PST143

Three one day Friday or Saturday or Sunday field trips (8:00am-5:00pm) are a required part of this course. Dates will be given the first day of class.

GEOL 102 - 3.0 UNITS PHYSICAL GEOLOGY LECTURE

Transferable to UC, CSU
Recommendation: ENGL 52 or ENGL 72 or ESL 152 or equivalent with a grade of "C" or higher or "Pass," or completion of the English placement tests with a score eligible for ENGL 100; and MATH 40 with a grade of "C" or higher or "Pass," or completion of the Math placement test with a score eligible for Math 60.

28709 7:00-9:50PM M Amin,J PST143

GEOL 102L - 1.0 UNIT PHYSICAL GEOLOGY LABORATORY

Transferable to UC, CSU
Prerequisite: GEOL 102 or equivalent with a grade of "C" or higher or "Pass" or concurrent enrollment.

Recommendation: ENGL 52 or ENGL 72 or ESL 152 or equivalent with a grade of "C" or higher or "Pass" or completion of the English placement process with a score eligible for ENGL 100; and MATH 40 or equivalent with a grade of "C" or higher or "Pass" or completion of the math placement process with a score eligible for MATH 60.

28710 7:00-9:50PM W Amin,J PST143

GEOL 103 - 3.0 UNITS ENVIRONMENTAL GEOLOGY LECTURE

Transferable to UC, CSU
Recommendation: ENGL 100 or equivalent with a grade of "C" or higher or "Pass" and MATH 40 or equivalent with a grade of "C" or higher or "Pass" or completion of the math placement process with a score eligible for MATH 60.

28713 8:00-10:50AM T lwaz,N PST137

GEOL 103L - 1.0 UNIT ENVIRONMENTAL GEOLOGY LABORATORY

Transferable to UC, CSU
Prerequisite: GEOL 103 or equivalent with a grade of "C" or higher or "Pass" or concurrent enrollment.

28714 8:00-10:50AM Th lwaz,N PST137

GEOL 105L - 1.0 UNIT FIELD METHODS OF THE EARTH SCIENCES

Transferable to CSU
Prerequisite: GEOL 101 or a combination of GEOL 102 and GEOL 102L or equivalent with a grade of "C" or higher or "Pass."

29672 9:30-10:45AM TTh Lacy,T PST143

GEOL 201 - 4.0 UNITS EARTH HISTORY

Transferable to UC, CSU (CAN GEOL 4)
Recommendation: ENGL 52 or ENGL 72 or ESL 152 or equivalent with a grade of "C" or higher or "Pass" or completion of the English placement process with a score eligible for ENGL 100, and MATH 40 or equivalent with a grade of "C" or higher or "Pass" or completion of the math placement process with a score eligible for MATH 60.

23654 6:00-7:30PM TTh STAFF PST143
7:30-8:45PM TTh STAFF PST143

GEOL 208 - 3.0 UNITS THE AGE OF THE DINOSAURS

Transferable to UC, CSU
Recommendation: ENGL 52 or ENGL 72 or ESL 152 or equivalent with a grade of "C" or higher or "Pass," or completion of the English placement process with a score eligible for ENGL 100.

28711 6:00-8:45PM W STAFF PST137

Two one day Saturday or Sunday field trips (8:00am-5:00pm) are a required part of this course. Dates will be given the first day of class.

GERMAN

GERM 101 - 5.0 UNITS ELEMENTARY GERMAN

Transferable to UC, CSU (CAN GERM 2)
29882 4:30-6:45PM TTh STAFF LC134
+ 1.0 HRS ARR STAFF LC205
LAB IS ONE HOUR PER WEEK IN THE SUCCESS CENTER
22611 4:30-6:45PM MW STAFF LC134
+ 1.0 HRS ARR STAFF LC205
LAB IS ONE HOUR PER WEEK IN THE SUCCESS CENTER

GERM 102 - 5.0 UNITS ELEMENTARY GERMAN

Transferable to UC, CSU (CAN GERM 4)
Prerequisite: GERM 101 or equivalent with a grade of "C" or higher or "Pass".
29884 7:00-9:15PM TTh STAFF LC134
+ 1.0 HRS ARR STAFF LC205
LAB IS ONE HOUR PER WEEK IN THE SUCCESS CENTER

HEALTH EDUCATION

HED 100 - 3.0 UNITS CONTEMPORARY HEALTH PROBLEMS

Transferable to UC, CSU
21054 9:30-10:45AM TTh Richardson,C MC102
22391 9:30-10:45AM TTh May,R K 203
20423 9:30-10:45AM MW Grosfeld,S K 203
20425 11:00-12:15PM MW Hemmerling,K K 202
20426 11:00-12:15PM MW Richardson,C K 203
20430 8:00-9:15AM TTh Hemmerling,K CB104
20432 12:30-1:45PM TTh May,R K 202
20434 8:00-10:50AM F Artiaga,B K 202
20889 12:30-1:45PM MW Hemmerling,K K 202
26445 3.0 HRS ARR (OL) Kozlowski,T ONLINE
20890 3.0 HRS ARR (OL) Gonzalez,R ONLINE
21567 3.0 HRS ARR (OL) Gonzalez,R ONLINE
21573 3.0 HRS ARR (OL) Gonzalez,R ONLINE
26446 11:00-12:15PM TTh STAFF K 202
28810 9:30-10:45AM MW Hemmerling,K K 202
29731 9:30-12:20PM F Grosfeld,S K 203
21656 6.0 HRS ARR (OL) Murray,K ONLINE
Class# 21656 meets 01/13/2020-03/13/2020
21117 6.0 HRS ARR (OL) Bueno,N ONLINE
Class# 21117 meets 01/13/2020-03/13/2020
21572 6.0 HRS ARR (OL) Bueno,N ONLINE
Class# 21572 meets 03/23/2020-05/22/2020
22604 6.0 HRS ARR (OL) Murray,K ONLINE
Class# 22604 meets 03/23/2020-05/22/2020
26835 6.0 HRS ARR (OL) Murray,K ONLINE
Class# 26835 meets 03/23/2020-05/22/2020
29222 6.0 HRS ARR (OL) STAFF ONLINE
Class# 29222 meets 03/23/2020-05/22/2020
29732 8:00-10:50AM MW STAFF MC104
Class# 29732 meets 03/23/2020-05/20/2020
20422 11:00-1:50PM TTh STAFF MC102
Class# 20422 meets 03/24/2020-05/21/2020
23267 6:00-8:50PM TTh STAFF K 204
Class# 23267 meets 03/24/2020-05/21/2020

HED 101 - 3.0 UNITS STRESS MANAGEMENT

Transferable to CSU
20891 1:00-2:15PM MW STAFF K 203
30088 6.0 HRS ARR (OL) Jensen,D ONLINE
Class# 30088 meets 01/13/2020-03/13/2020
30089 6.0 HRS ARR (OL) Jensen,D ONLINE
Class# 30089 meets 01/13/2020-03/13/2020
30090 6.0 HRS ARR (OL) Jensen,D ONLINE
Class# 30090 meets 03/23/2020-05/22/2020
30091 6.0 HRS ARR (OL) Jensen,D ONLINE
Class# 30091 meets 03/23/2020-05/22/2020

HED 103 - 3.0 UNITS WOMEN, THEIR BODIES AND HEALTH

Transferable to CSU
23266 9:30-10:45AM MW STAFF (Women's Studies) SS138
20435 6:30-9:20PM TTh STAFF (Women's Studies) SS307
Class# 20435 meets 03/24/2020-05/21/2020

Students not in attendance or late for the first class meeting are subject to drop.

Class#	Time	Day	Instructor	Room	Class#	Time	Day	Instructor	Room
--------	------	-----	------------	------	--------	------	-----	------------	------

HED 104 - 3.0 UNITS INTRODUCTION TO HEALTH AND SOCIETY

Transferable to CSU

29733	3.0 HRS ARR	(OL)	STAFF	ONLINE
-------	-------------	------	-------	--------

HED 105 - 3.0 UNITS MIND, BODY, AND HEALTH

Transferable to CSU

Prerequisite: Completion of HED 100 or equivalent with a grade of "C" or higher, or "Pass".

28972	3.0 HRS ARR	(OL)	STAFF	ONLINE
-------	-------------	------	-------	--------

HED 110 - 3.0 UNITS COMMUNITY FIRST AID AND CPR

Transferable to CSU

21571	9:30-10:45AM	MW	STAFF	K 205
26419	7:00-9:50PM	T	STAFF	K 205
20436	8:00-10:50AM	F	STAFF	K 205
29734	12:30-1:45PM	TTh	STAFF	K 205

HED 200 - 3.0 UNITS NUTRITION FOR HEALTH, FITNESS, AND PHYSICAL ACTIVITY

Transferable to UC, CSU

21570	9:30-10:45AM	MW	Bueno,N	K 204
-------	--------------	----	---------	-------

HED 202 - 3.0 UNITS HEALTH SYSTEMS AND PERSPECTIVES

Transferable to CSU

Prerequisite: Completion of HED 100 or equivalent with a grade of "C" or higher, or "Pass".
 Recommendation: Completion of ENGL 100 or equivalent with a grade of "C" or higher, or "Pass".

28973	6.0 HRS ARR	(OL)	Bueno,N	ONLINE
-------	-------------	------	---------	--------

Class# 28973 meets 01/13/2020-03/13/2020

HEALTH OCCUPATIONS

HO 53 - 1.0 UNIT ELECTROCARDIOGRAPHY

Not Transferable

27072	9:00-11:00AM	Th	STAFF	SL105
	11:00-1:50PM	Th	STAFF	SL105

Class# 27072 meets 01/16/2020-02/20/2020

HO 54 - 1.0 UNIT MEDICAL LABORATORY SKILLS

Not Transferable

27076	9:00-11:00AM	Th	STAFF	SL105
	11:00-1:50PM	Th	STAFF	SL105

Class# 27076 meets 02/27/2020-04/09/2020

HO 55 - 1.5 UNITS PHLEBOTOMY PROCEDURES

Not Transferable

Recommendation: MA 161 or equivalent with a grade of "C" or higher or "Pass".

27078	9:00-11:00AM	T	STAFF	SL105
	11:00-1:50PM	T	STAFF	SL105

Class# 27078 meets 01/14/2020-03/10/2020

HO 56 - 1.0 UNIT MEDICATION CALCULATIONS

Not Transferable

Prerequisite: MATH 40 or equivalent with a grade of "C" or higher or "Pass" or satisfactory completion of the Math Placement Process.

22393	9:00-10:50AM	W	Makarem,N	SL108
-------	--------------	---	-----------	-------

Class# 22393 meets 01/15/2020-03/11/2020

28721	11:00-12:50PM	F	Gonzalez,K	SL106
-------	---------------	---	------------	-------

Class# 28721 meets 03/27/2020-05/22/2020

HO 152 - 3.0 UNITS NORMAL AND THERAPEUTIC NUTRITION

Transferable to UC, CSU (CAN FCS 2)

Recommendation: A&P 150 and A&P 151 or equivalent with grades of Pass or "C" or higher.

20448	4:00-6:50PM	Th	Caminiti,C	SL109
-------	-------------	----	------------	-------

HISTORY

HIST 102 - 3.0 UNITS POLITICAL AND SOCIAL HISTORY OF THE UNITED STATES: 1500S TO

Transferable to UC, CSU (CAN HIST 8)(CAN HIST SEQ B)

Prerequisite: Satisfactory completion of English Placement Process or ENGL 52, ENGL 72, or ESL 152 or equivalent with a grade of "C" or higher or "Pass".
 Recommendation: Satisfactory completion of the Reading Placement Process or READ 54 with a grade of "C" or higher or "Pass".

20442	11:00-12:15PM	MW	Haas,J	SS309
-------	---------------	----	--------	-------

Note: Targeted for Future Teachers but Open to all Students

22555	2:00-3:15PM	TTh	Fernandez,W	SS311
20443	8:00-9:15AM	MW	Davis,J	SS311

Note: Targeted for Future Teachers but Open to all Students

20893	8:00-9:15AM	TTh	Haas,J	SS309
-------	-------------	-----	--------	-------

Note: Targeted for Future Teachers but Open to all Students

22625	5:30-6:45PM	TTh	Macias,J	SS310
23343	2:00-3:15PM	MW	Fernandez,W	SS311
23344	5:30-6:45PM	MW	Fernandez,W	SS311
23813	8:00-9:15AM	TTh	Read,R	SS310
27276	3.0 HRS ARR	(OL)	Heeren,J	ONLINE

Online orientation will be available in Canvas.

21945	9:30-10:45AM	MW	Davis,J	SS311
22209	11:00-12:15PM	TTh	Read,R	SS310
26328	6:30-7:45AM	MW	Hall,D	SS310
26399	7:00-9:50PM	Th	Heerin,J	SS310
26686	12:30-1:45PM	MW	Staff	SS311
27277	3:30-4:45PM	TTh	Waszak,L	SS309
28050	3.0 HRS ARR	(OL)	Swendson,P	ONLINE

Online orientation via Canvas for History 102 is to be completed during the first week of class.

28051	3.0 HRS ARR	(OL)	Swendson,P	ONLIN
-------	-------------	------	------------	-------

Online orientation via Canvas for History 102 is to be completed during the first week of class.

28243	9:30-11:00AM	TTh	Read,R	HS103
-------	--------------	-----	--------	-------

Class# 28243 meets 02/04/2020-05/21/2020

21687	7:00-10:05PM	MW	Hawkins,M	SS311
--------------	---------------------	-----------	-----------	-------

Class# 21687 meets 01/13/2020-03/11/2020

24178	7:00-9:50PM	MW	Hawkins,M	SS311
--------------	--------------------	-----------	-----------	-------

Class# 24178 meets 03/23/2020-05/20/2020

HIST 103 - 3.0 UNITS POLITICAL AND SOCIAL HISTORY OF THE UNITED STATES: 1877 TO P

Transferable to UC, CSU (CAN HIST 10)(CAN HIST SEQ B)

Prerequisite: Satisfactory completion of English Placement Process or ENGL 52, ENGL 72, or ESL 152 or equivalent with a grade of "C" or higher or "Pass".
 Recommendation: Satisfactory completion of the Reading Placement Process or READ 54 with a grade of "C" or higher or "Pass".

20444	11:00-12:15PM	TTh	STAFF	SS309
26329	8:00-9:15AM	MW	Hall,D	SS310
22556	8:00-9:15AM	TTh	Davis,J	SS311
22557	9:30-11:00AM	TTh	Jarrett,G	SS310
21946	5:30-6:45PM	MW	Macias,J	SS310

Note: Emphasis on the Mexican American/Latino(a) experience.

21688	9:30-10:45AM	MW	Hall,D	SS310
21689	11:00-12:15PM	MW	Latson,J	SS310
22558	12:30-1:45PM	TTh	Macias,J	SS310

Note: Emphasis on the Mexican American/Latino(a) experience.

22622	7:00-9:50PM	T	Hawkins,M	SS310
--------------	--------------------	----------	-----------	-------

23766	12:30-1:45PM	TTh	Jarrett,G	SS309
24179	9:00-11:50AM	F	Hunt,R	SS310
24180	2:00-3:15PM	MW	Macias,J	SS310

Note: Emphasis on the Mexican American/Latino(a) experience.

26997	9:30-10:45AM	TTh	Davis,J	SS311
27278	3.0 HRS ARR	(OL)	Heeren,J	ONLINE

Orientation will be available in Canvas.

28052	3.6 HRS ARR	(OL)	Hunt,R	ONLINE
-------	-------------	------	--------	--------

Online orientation via Canvas for History 103 is to be completed during the first week of class.

Class# 28052 meets 01/13/2020-05/01/2020

22385	7:00-9:50PM	TTh	Mishler,K	SL109
--------------	--------------------	------------	-----------	-------

Class# 22385 meets 01/14/2020-03/12/2020

Note: Emphasis on transportation in U.S. History. Targeted for AUTO, but open to all students.

Class#	Time	Day	Instructor	Room	Class#	Time	Day	Instructor	Room
HIST 110 - 3.0 UNITS AFRICAN/AMERICAN HISTORY Transferable to UC, CSU Recommendation: Completion of ENGL 52, or ENGL 72, or ESL 152, or equivalent with a grade of "C" or higher or "Pass" or completion of the placement process with eligibility for ENGL 100 and satisfactory completion of the Reading Placement Process or READ 43 or READ 49 with a grade of "C" or higher or "Pass" This course is a survey of the political, legal, economic, and social position and role of African-Americans in the history of the United States.					HIST 255 - 3.0 UNITS HISTORY OF RUSSIA AND THE SOVIET UNION Transferable to UC, CSU Recommendation: Satisfactory completion of the English Placement Process or ENGL 52 or equivalent with a grade of "C" or higher or "Pass" and satisfactory completion of the Reading Placement Process or READ 54 with a grade of "C" or higher or "Pass".				
24181	12:30-2:00PM	TTh	Melton,J	SS308	29707	11:00-12:30PM	TTh	Waszak,L	SS138
Class# 24181 meets 02/04/2020-05/21/2020					Class# 29707 meets 02/04/2020-05/21/2020				
HIST 120 - 3.0 UNITS HISTORY OF CALIFORNIA Transferable to UC, CSU Recommendation: Satisfactory completion of the English Placement Process or ENGL 20 or equivalent with a grade of "C" or higher or "Pass" and satisfactory completion of the Reading Placement Process or READ 43 and READ 49 with a grade of "C" or higher or "Pass".					HIST 275 - 3.0 UNITS GLOBAL STUDIES Transferable to UC, CSU Recommendation: ENGL 52 or equivalent with a grade of "C" or higher or "Pass".				
20441	2:00-3:15PM	TTh	Macias,J	SS310	22386	2:00-3:30PM	MW	Haas,J	SS309
Class# 20441 meets 02/03/2020-05/20/2020					Class# 22386 meets 02/03/2020-05/20/2020				
HIST 210 - 3.0 UNITS HISTORY OF THE UNITED STATES IN THE POST WORLD WAR II ERA Transferable to UC, CSU Recommendation: Satisfactory completion of the Reading Placement Process or READ 54 or equivalent with a grade of "C" or higher or "Pass" and satisfactory completion of the English Placement Process or ENGL 52 or equivalent with a grade of "C" or higher or "Pass".					HUM 100 - 3.0 UNITS THE ART OF BEING HUMAN Transferable to UC, CSU Recommendation: ENGL 52, ENGL 72 or ESL 152 AND READ 54 or READ 97 or equivalent with grades of Pass or "C" or higher.				
20445	12:30-1:45PM	MW	Jarrett,G	SS310	20449	6.0 HRS ARR	(OL)	Trager,J	ONLINE
Class# 20445 meets 03/23/2020-05/22/2020					Class# 20449 meets 03/23/2020-05/22/2020				
HIST 230 - 3.0 UNITS HISTORY OF MEXICO Transferable to UC, CSU Recommendation: Satisfactory completion of the English Placement Process or ENGL 20 or equivalent with a grade of "C" or higher or "Pass" and satisfactory completion of the Reading Placement Process or READ 43 or READ 49 with a grade of "C" or higher or "Pass".					23309 8:00-10:50AM TTh Trager,J FA134 Class# 23309 meets 01/14/2020-03/12/2020				
20895	5:30-6:45PM	TTh	Fernandez,W	SS311	HUM 107 - 3.0 UNITS MEN AND MASCULINITIES: CONSTRUCTING MANHOOD IN AMERICA Transferable to UC, CSU Prerequisite: Completion of ENGL 52, or ENGL 72, or ESL 152 or equivalent with a grade of "C" or higher, or "Pass," or completion of the English Placement Process with eligibility for ENGL 100.				
21644	12:30-1:45PM	TTh	Fernandez,W	SS311	Recommendation: Completion of READ 54 or READ 97 with a grade of "C" or higher, or "Pass," or completion of the Reading Placement Process with a score of "Reading Exempt."				
HIST 235 - 3.0 UNITS HISTORY OF LATIN AMERICA Transferable to UC, CSU Recommendation: Satisfactory completion of the English Placement Process or ENGL 52 or equivalent with a grade of "C" or higher or "Pass" and satisfactory completion of the Reading Placement Process or READ 54 with a grade of "C" or higher or "Pass".					29718 11:00-1:50PM MW Trager,J (Honors Section) FA134 Class# 29718 meets 01/13/2020-03/11/2020				
20896	11:00-12:15PM	MW	Fernandez,W	SS311	HUM 108 - 3.0 UNITS BLACK IMAGES IN POPULAR CULTURE Transferable to UC, CSU Recommendation: ENGL 52 and READ 54 or equivalent with grades of Pass or "C" or higher is strongly recommended.				
HIST 242 - 3.0 UNITS WESTERN CIVILIZATION Transferable to UC, CSU (CAN HIST 4)(CAN HIST SEQ A) Prerequisite: Completion of ENGL 52, or ENGL 72 or ESL 152 or equivalent with a grade of "C" or higher, or "Pass," or completion of the English Placement Process with eligibility for ENGL 100.					28182 3:30-6:20PM TTh Trager,J (Honors Section) FA134 Class# 28182 meets 01/14/2020-03/12/2020				
22363	2:00-3:15PM	TTh	Waszak,L	SS309	HUM 109 - 3.0 UNITS GENDER AND SEXUALITY IN ART Transferable to UC, CSU Recommendation: ENGL 52 and READ 54 or equivalent with grades of Pass or "C" or higher is strongly recommended.				
HIST 245 - 3.0 UNITS WORLD CIVILIZATION FROM ANTIQUITY TO 1500 Transferable to UC, CSU Recommendation: READ 54 and ENGL 52 or equivalent with grades of Pass or "C" or higher.					29716 2:30-5:20PM MW Trager,J FA134 Class# 29716 meets 01/13/2020-03/11/2020				
20446	9:30-10:45AM	MW	Haas,J	SS309	HUM 125 - 3.0 UNITS INTRODUCTION TO VISUAL AND CULTURAL STUDIES Transferable to CSU Recommendation: ENGL 52 or ENGL 72 or ESL 152 or equivalent with a grade of "C" or higher or Pass or completion of the English placement process with a score eligible for ENGL 100 and READ 54 or READ 97 or equivalent with a grade of "C" or higher or Pass or completion of the Reading placement process with a score of "Reading Exempt."				
22559	5:30-6:45PM	MW	Haas,J	SS309	30127 12:30-3:20PM Th Vitela,L (HYBRID) FA133 Class# 30127 meets 01/16/2020-03/12/2020				
HIST 246 - 3.0 UNITS WORLD CIVILIZATION FROM 1500 TO PRESENT Transferable to UC, CSU Recommendation: READ 54 and ENGL 52 or equivalent with grades of Pass or "C" or higher.									
23870	3:30-4:45PM	MW	Latson,J	SS310					
HIST 250 - 3.0 UNITS HISTORY OF ENGLAND, GREAT BRITAIN AND THE COMMONWEALTH Transferable to UC, CSU Recommendation: Satisfactory completion of the English Placement Process or ENGL 52 or equivalent with a grade of "C" or higher or "Pass" and satisfactory completion of the Reading Placement Process or READ 54 with a grade of "C" or higher or "Pass".									
20447	9:30-11:00AM	TTh	Haas,J	SS309					
Class# 20447 meets 02/04/2020-05/21/2020									

HUMANITIES

Students not in attendance or late for the first class meeting are subject to drop.

Class#	Time	Day	Instructor	Room	Class#	Time	Day	Instructor	Room
--------	------	-----	------------	------	--------	------	-----	------------	------

INTERDISCIPLINARY STUDIES

INST 151 - 3.0 UNITS PRINCIPLES OF RECOVERY AND PSYCHOSOCIAL REHABILITATION

Transferable to CSU

21947 6:30-9:20PM T Costello,C BE119

INST 152 - 3.0 UNITS HELPING RELATIONSHIPS

Transferable to CSU

Prerequisite: INST 151 with a grade of "C" or higher or "Pass".

21860 6:30-9:20PM Th Martins,M BE116

INST 272 - 3.0 UNITS SPECIAL POPULATIONS

Transferable to CSU

28101 6:30-9:20PM W Martins,M BE105

JAPANESE

JAPN 101 - 5.0 UNITS ELEMENTARY JAPANESE

Transferable to UC, CSU

21865 2:00-4:15PM TTh Mochizuki,S LC134
+ 1.0 HRS ARR Mochizuki,S LC205

LAB IS ONE HOUR PER WEEK IN THE SUCCESS CENTER

21869 10:00-12:15PM MW Larsen,T LA103
+ 1.0 HRS ARR Larsen,T LC205

LAB IS ONE HOUR PER WEEK IN THE SUCCESS CENTER

28892 12:30-2:45PM MW Larsen,T LC134
+ 1.0 HRS ARR Larsen,T LC205

LAB IS ONE HOUR PER WEEK IN THE SUCCESS CENTER

29886 4:30-6:45PM TTh Mochizuki,S SS214
+ 1.0 HRS ARR Mochizuki,S LC205

LAB IS ONE HOUR PER WEEK IN THE SUCCESS CENTER

29888 7:00-9:15PM MW STAFF LC134
+ 1.0 HRS ARR STAFF LC205

LAB IS ONE HOUR PER WEEK IN THE SUCCESS CENTER

JOURNALISM

JOUR 100 - 3.0 UNITS MASS COMMUNICATIONS AND SOCIETY

Transferable to UC, CSU (CAN JOUR 4)

20452 9:30-10:50AM MW Brown,C FA134
28134 3.0 HRS ARR (OL) STAFF ONLINE

JOUR 101 - 3.0 UNITS BEGINNING NEWSWRITING AND REPORTING

Transferable to UC, CSU (CAN JOUR 2)

Prerequisite: Completion of ENGL 52, or ENGL 72 or ESL 152 or equivalent with a grade of "C" or higher, or "Pass," or completion of the English Placement Process with eligibility for ENGL 100.

20453 9:30-10:50AM TTh Brown,C FA245

JOUR 107A - 3.0 UNITS COLLEGE NEWSPAPER

Transferable to CSU

Recommendation: JOUR 101 or JOUR 121 or equivalents with a grade of "C" or higher or "Pass".

23310 12:30-1:30PM MW Brown,C FA245
1:30-2:50PM MW Brown,C FA245

JOUR 107B - 3.0 UNITS INTERMEDIATE COLLEGE NEWSPAPER

Transferable to CSU

Prerequisite: JOUR 107A or equivalent with a grade of Pass or "C" or better.

23312 12:30-1:30PM MW Brown,C FA245
1:30-2:50PM MW Brown,C FA245

JOUR 107C - 3.0 UNITS INTERMEDIATE ADVANCED COLLEGE NEWSPAPER

Transferable to CSU

Prerequisite: JOUR 107B or equivalent with a grade of Pass or "C" or better.

23314 12:30-1:30PM MW Brown,C FA245
1:30-2:50PM MW Brown,C FA245

JOUR 107D - 3.0 UNITS ADVANCED COLLEGE NEWSPAPER

Transferable to CSU

Prerequisite: JOUR 107C or equivalent with a grade of Pass or "C" or better.

23316 12:30-1:30PM MW Brown,C FA245
1:30-2:50PM MW Brown,C FA245

JOUR 121 - 3.0 UNITS MULTIMEDIA REPORTING

Transferable to CSU

Recommendation: JOUR 101 or equivalent with a grade of "C" or higher or "Pass".

22886 3:00-4:00PM MW Edquist,A FA245
4:00-5:15PM MW Edquist,A FA245

KINESIOLOGY

KIN 100 - 3.0 UNITS INTRODUCTION TO KINESIOLOGY

Transferable to UC, CSU

25146 9:30-10:45AM MW STAFF K 206
25147 9:30-10:45AM TTh STAFF K 206

26420 6:00-7:15PM MW STAFF K 206
26741 11:00-12:15PM TTh STAFF K 206

27860 3.0 HRS ARR (OL) Edwards,C ONLINE
28140 3.0 HRS ARR (OL) STAFF ONLINE

28842 11:00-12:15PM MW Macias,S K 206
29735 12:30-1:45PM TTh STAFF K 206

29736 3:00-4:15PM MW STAFF K 206
28141 6.0 HRS ARR (OL) STAFF ONLINE

Class# 28141 meets 03/23/2020-05/22/2020
28843 6.0 HRS ARR (OL) STAFF ONLINE

Class# 28843 meets 03/23/2020-05/22/2020
29193 6.0 HRS ARR (OL) STAFF ONLINE

Class# 29193 meets 03/23/2020-05/22/2020
29221 6.0 HRS ARR (OL) STAFF ONLINE

Class# 29221 meets 03/23/2020-05/22/2020
28115 11:00-1:50PM MW STAFF MC104

Class# 28115 meets 03/23/2020-05/20/2020

KIN 102 - 3.0 UNITS INTRODUCTION TO ATHLETIC TRAINING

Transferable to UC, CSU

25148 8:00-9:15AM MW STAFF K 206

KIN 104 - 3.0 UNITS FITNESS AND WELLNESS

Transferable to UC, CSU

25323 1:00-1:50PM MW STAFF CB103

NOTE: Students must select one (1) lecture and one (1) lab.

When registering enter the class # for lecture FIRST. When pop-up box

appears asking for the accompanying section, enter the lab class number #.

LECTURE OPTIONS APPEAR BELOW

25324 8:30-9:20AM TTh Kozlowski,T K 202
25326 2.0 HRS ARR (OL) Edwards,C ONLINE

25327 9:30-10:45AM MW Kozlowski,T K 129

NOTE: LAB OPTIONS APPEAR BELOW. Select one (1) lab section to

accompany your lecture selection. Lecture sections and registration

instructions appear above.

25328 11:00-12:15PM MW Edwards,C K 129
25329 2:00-3:15PM MW STAFF K 129

25330 9:30-10:45AM TTh Kozlowski,T K 129
29737 6:00-7:15PM TTh STAFF K 129

KIN 108 - 3.0 UNITS WOMEN IN SPORTS

Transferable to CSU

25335 3.0 HRS ARR Kozlowski,T (Women's Studies) ONLINE
27222 6.0 HRS ARR (OL) Kozlowski,T ONLINE

Class# 27222 meets 03/23/2019-05/24/2019

KIN 110 - 3.0 UNITS COMMUNITY FIRST AID AND CPR

Transferable to CSU

29032 9:30-10:45AM MW STAFF K 205
29033 8:00-10:50AM F STAFF K 205

29034 7:00-9:50PM T STAFF K 205
29738 12:30-1:45PM TTh STAFF K 205

KIN 123 - 1.0 UNIT SPORTS OFFICIATING FOR MEN'S AND WOMEN'S TRACK AND FIELD

Transferable to UC, CSU

26450 8:30-10:45AM Sat STAFF K 206
Class# 26450 meets 01/18/2020-03/14/2020

Students not in attendance or late for the first class meeting are subject to drop.

Class#	Time	Day	Instructor	Room	Class#	Time	Day	Instructor	Room
KIN 131 - 2.0 UNITS THEORY OF COACHING BASEBALL Transferable to UC, CSU					LAW 101 - 3.0 UNITS INTRODUCTION TO LAW Transferable to CSU				
29023	9:00-10:50AM	F	STAFF	K 206	22082	7:00-9:50PM	Th	Filer,A	SS137
KIN 200 - 3.0 UNITS SPORTS PSYCHOLOGY Transferable to CSU					22105	11:00-12:15PM	TTh	Sauber,D	SS136
29739	8:00-9:15AM	TTh	Richardson,C	K 203	26669	11:00-12:15PM	MW	Binning,M	SS138
29740	3.0 HRS ARR	(OL)	Gonzalez,R	ONLINE	29135	7:05-8:40AM	MF	Tchulluiian,L	BELF*
KIN 203 - 3.0 UNITS PROGRAMS AND PRINCIPLES OF CONDITIONING Transferable to UC, CSU					Class# 29135 meets 02/03/2020-05/22/2020				
25338	11:00-12:15PM	MW	Bueno,N	K 205	LAW 102 - 3.0 UNITS ADVANCED CALIFORNIA CIVIL PROCEDURES Transferable to CSU Prerequisite: LAW 100 with a grade of "C" or higher or "Pass". Recommendation: LAW 56 with a grade of "C" or higher or "Pass".				
KIN 205 - 3.0 UNITS ANATOMICAL MOVEMENT ANALYSIS Transferable to UC, CSU					22083	7:00-9:50PM	T	Noyes,N	BE117
28982	12:30-1:45PM	MW	Castro,M	K 205	28661	12:30-1:45PM	MW	Noyes,N	BE120
KIN 206B - 2.0 UNITS UPPER EXTREMITY INJURY ASSESSMENT AND RECONDITIONING Transferable to UC, CSU					LAW 103 - 3.0 UNITS LEGAL RESEARCH Transferable to CSU Recommendation: LAW 101 and LAW 56 or equivalent with grades of Pass or "C" or higher.				
28844	8:00-8:30AM	TTh	Castro,M	K 205	22084	9:30-10:45AM	TTh	Greenberg,B	LC 22
	8:30-9:50AM	TTh	Castro,M	K 205	22085	6:00-8:50PM	T	Greenberg,B	LC 22
KIN 207 - 1.0 UNIT ATHLETIC INJURY TAPING, BANDAGING AND IMMOBILIZATION Transferable to CSU					LAW 104 - 3.0 UNITS ADVANCED LEGAL RESEARCH Transferable to CSU Prerequisite: LAW 103 or equivalent with a grade of "C" or higher or "Pass". Recommendation: LAW 56 or equivalent with a grade of "C" or higher or "Pass".				
25341	10:00-10:15AM	TTh	Castro,M	K 205	22570	7:00-9:50PM	F	Maline,R	BE119
	10:15-10:50AM	TTh	Castro,M	K 205	LAW 106 - 3.0 UNITS BANKRUPTCY LAW Transferable to CSU Recommendation: LAW 56 with a grade of "C" or higher or "Pass".				
KIN 211 - 3.0 UNITS SPORT MANAGEMENT Transferable to CSU					23703	7:00-9:50PM	W	Binning,M	BE117
28113	11:00-12:15PM	MW	STAFF	K 204	LAW 108 - 3.0 UNITS FAMILY LAW PROCEDURES Transferable to CSU Recommendation: LAW 56 with a grade of "C" or higher or "Pass".				
29741	6:00-8:50PM	M	STAFF	K 204	22499	7:00-9:50PM	M	Filer,A	BE117
KIN 271A - 1.0 UNIT OCCUPATIONAL WORK EXPERIENCE ATHLETIC TRAINING Transferable to CSU					LAW 110 - 3.0 UNITS BUSINESS LAW Transferable to UC, CSU 3.0 HRS ARR Binning,M (OL) Orientation: 7:00 - 7:50 pm, Friday - January 17 in BE 116.				
25343	1.0 HRS ARR	STAFF		K 205	28662	6:30-10:00PM	M	Kim,R	SS136
KIN 271B - 1.0 UNIT OCCUPATIONAL WORK EXPERIENCE IN FITNESS Transferable to CSU					Class# 28662 meets 02/03/2020-05/18/2020				
25344	1.0 HRS ARR	STAFF		K 205	LAW 111 - 3.0 UNITS BUSINESS LAW Transferable to UC, CSU (CAN BUS 8)				
KIN 298 - 1.0 UNIT DIRECTED STUDIES Transferable to CSU					22087	11:00-12:15PM	MW	Noyes,N	BE116
25345	2.0 HRS ARR		Grosfeld,S	K 129	22090	6:30-9:50PM	Th	Brown Jr.,W	SS138
Note: Must have instructor approval before registering Class# 25345 meets 01/13/2020-03/13/2020					Class# 22090 meets 02/06/2020-05/21/2020				
25346	2.0 HRS ARR		Grosfeld,S	K 129	27260	3.0 HRS ARR	(OL)	Noyes,N	ONLINE
Note: Must have instructor approval before registering Class# 25346 meets 03/23/2020-05/22/2020					Orientation: 6:00 - 6:50 pm, Friday - January 17 in BE 116.				
KIN 299 - 2.0 UNITS DIRECTED STUDIES Transferable to CSU					LAW 112 - 3.0 UNITS ESTATE PLANNING FOR THE PARALEGAL Transferable to CSU Recommendation: LAW 56 with a grade of "C" or higher or "Pass".				
25348	1.2 HRS ARR		Grosfeld,S	K 129	28047	7:00-9:50PM	Th	Binning,M	LC 22
Note: Must have instructor approval before registering Class# 25348 meets 02/03/2020-05/22/2020					LAW 113 - 3.0 UNITS FUNDAMENTALS OF ALTERNATE DISPUTE RESOLUTIONS Transferable to CSU Recommendation: LAW 56 with a grade of "C" or higher or "Pass".				
LAW									
LAW 56 - 3.0 UNITS INTRODUCTION TO COMPUTERIZED LEGAL SOFTWARE Not Transferable					LAW 116 - 3.0 UNITS CRIMINAL LAW Transferable to CSU				
22412	9:30-10:45AM	MW	Noyes,N	BE117	22542	7:00-9:50PM	M	Maline,R	BE110
22133	7:00-9:50PM	F	Noyes,N	BE117	LAW 120 - 3.0 UNITS LEGAL ETHICS Transferable to CSU				
LAW 65 - 3.0 UNITS ADVANCED LEGAL TECHNOLOGY Not Transferable					22095	12:30-1:45PM	TTh	Sauber,D	BE106
Recommendation: LAW 56 or equivalent with a grade of "C" or higher or "Pass".					22096	7:00-9:50PM	W	Sauber,D	BE106
28660	5:30-6:45PM	MW	Binning,M	BE117	LAW 160 - 3.0 UNITS CALIFORNIA WORKERS' COMPENSATION LAW Transferable to CSU Recommendation: Completion of ENGL 52, ENGL 72, or ESL 152 or equivalent with a grade of "C" or higher, or "Pass," or completion of the English Placement Process with eligibility for ENGL 100.				
LAW 100 - 3.0 UNITS INTRODUCTION TO CALIFORNIA CIVIL PROCEDURES Transferable to CSU					27279	7:00-9:50PM	W	Tchulluiian,L	LC 22
Recommendation: LAW 56 with a grade of "C" or higher or "Pass".									
22079	8:00-9:15AM	TTh	Greenberg,B	LC 22					
22080	7:00-9:50PM	M	Binning,M	LC 22					

Students not in attendance or late for the first class meeting are subject to drop.

Class#	Time	Day	Instructor	Room	Class#	Time	Day	Instructor	Room
LAW 171 - 1.0 UNIT LEGAL OCCUPATIONAL WORK EXPERIENCE Transferable to CSU					MTT 68 - 2.0 UNITS COMPUTER-ASSISTED INSPECTION USING VERISURF Not Transferable				
22097	1:00-1:50PM	W	Greenberg,B	LC 22	26195	8:00-12:15PM	Sat	Husted,C	ME 2J
22101	6:00-6:50PM	W	Greenberg,B	LC 22	Class# 26195 meets 01/18/2020-03/14/2020				
LAW 172 - 2.0 UNITS LEGAL OCCUPATIONAL WORK EXPERIENCE Transferable to CSU					MTT 78 - 1.0 UNIT TOOL BUILDING USING VERISURF Not Transferable				
22098	1:00-1:50PM	W	Greenberg,B	LC 22	Prerequisite: MTT 68 or equivalent with a grade of "C" or higher or "Pass."				
22102	6:00-6:50PM	W	Greenberg,B	LC 22	Recommendation: ENGT 117 and MTT 56.				
LAW 173 - 3.0 UNITS LEGAL OCCUPATIONAL WORK EXPERIENCE Transferable to CSU					27817	8:00-10:15AM	Sat	Husted,C	ME 2J
22099	1:00-1:50PM	W	Greenberg,B	LC 22		10:45-11:45AM	Sat	Husted,C	ME 2J
22103	6:00-6:50PM	W	Greenberg,B	LC 22	Class# 27817 meets 03/28/2020-05/16/2020				
LAW 174 - 4.0 UNITS LEGAL OCCUPATIONAL WORK EXPERIENCE Transferable to CSU					MTT 91L - 1.0 UNIT CNC MILL MACHINING LABORATORY Not Transferable				
22100	1:00-1:50PM	W	Greenberg,B	LC 22	Prerequisite: MTT 51 and MTT 52 with a grade of "C" or higher or "Pass."				
22104	6:00-6:50PM	W	Greenberg,B	LC 22	22307	5:30-8:20PM	F	Vo,C	ME 3H
LAW 290 - 1.0 UNIT CAPSTONE COURSE-PARALEGAL PROGRAM Transferable to CSU					MTT 92L - 1.0 UNIT MASTERCAM LABORATORY Not Transferable				
Recommendation: To be taken in the final semester of course work for certificate students, and to be taken in the final semester prior to graduation for Paralegal A.					Prerequisite: MTT 51 or MTT 57 or equivalent with a grade of "C" or higher or "Pass" or appropriate work experience.				
22326	6:00-6:50PM	W	Kim,R	BE106	24245	5:30-8:20PM	Th	Barnes,J	ME 3H
23912	6:00-6:50PM	Th	Kim,R	BE105	MTT 94L - 1.0 UNIT MANUAL MACHINING LAB Not Transferable				

LIBRARY

LIBR 100 - 1.0 UNIT INTRODUCTION TO LIBRARY RESEARCH Transferable to UC, CSU				
28747	9:00-10:50AM	M	Taibjee,S	(HYBRID) LC 62
+ 2.0 HRS ARR Taibjee,S (HYBRID)				
Class# 28747 meets 01/13/2020-03/09/2020				
28749	6:00-7:50PM	Th	Daugherty,H	(HYBRID) LC 62
+ 2.0 HRS ARR Daugherty,H (HYBRID)				
Class# 28749 meets 01/16/2020-03/12/2020				

MACHINE TOOL TECHNOLOGY

MTT 51 - 3.5 UNITS MASTERCAM MILLING Not Transferable Please read the technical standards relevant to this department at https://www.cerritos.edu/technology/standards.htm .				
20941	5:30-8:30PM	M	Vo,C	ME 3H
	8:30-9:45PM	M	Vo,C	ME 3H
MTT 52 - 2.5 UNITS SETUP AND OPERATION OF CNC MILLING MACHINES Not Transferable				
20942	5:30-7:30PM	T	Vo,C	ME 2J
	7:30-8:45PM	T	Vo,C	ME 2J
MTT 57 - 2.5 UNITS SETUP AND OPERATION OF CNC LATHES Not Transferable				
21767	5:30-7:30PM	F	Vo,C	ME 3H
	7:30-8:45PM	F	Vo,C	ME 3H
MTT 59 - 2.5 UNITS MASTERCAM TURNING Not Transferable				
27123	5:30-7:30PM	T	Barnes,J	ME 3H
	7:30-8:45PM	T	Barnes,J	ME 3H
MTT 62 - 2.0 UNITS FIXTURE TOOLING Not Transferable Corequisite: MTT 52 or MTT 57 or MTT 68 or MTT 100 or ENGT 116 or ENGT 117 or ENGT 259 or equivalent or prior completion, with a grade of "C" or higher, or "Pass."				
26961	4.0 HRS ARR	(OL)	Real,Y	ONLINE
Class# 26961 meets 01/13/2020-03/13/2020				

MTT 68 - 2.0 UNITS COMPUTER-ASSISTED INSPECTION USING VERISURF Not Transferable				
26195	8:00-12:15PM	Sat	Husted,C	ME 2J
Class# 26195 meets 01/18/2020-03/14/2020				
MTT 78 - 1.0 UNIT TOOL BUILDING USING VERISURF Not Transferable				
Prerequisite: MTT 68 or equivalent with a grade of "C" or higher or "Pass."				
Recommendation: ENGT 117 and MTT 56.				
27817	8:00-10:15AM	Sat	Husted,C	ME 2J
	10:45-11:45AM	Sat	Husted,C	ME 2J
Class# 27817 meets 03/28/2020-05/16/2020				
MTT 91L - 1.0 UNIT CNC MILL MACHINING LABORATORY Not Transferable				
Prerequisite: MTT 51 and MTT 52 with a grade of "C" or higher or "Pass."				
22307	5:30-8:20PM	F	Vo,C	ME 3H
MTT 92L - 1.0 UNIT MASTERCAM LABORATORY Not Transferable				
Prerequisite: MTT 51 or MTT 57 or equivalent with a grade of "C" or higher or "Pass" or appropriate work experience.				
24245	5:30-8:20PM	Th	Barnes,J	ME 3H
MTT 94L - 1.0 UNIT MANUAL MACHINING LAB Not Transferable				
Prerequisite: MTT 56 and MTT 100 or equivalent with grades of Pass or "C" or higher.				
22306	5:30-8:20PM	W	Vo,C	ME 3H
MTT 95L - 1.0 UNIT CNC LATHE MACHINING LABORATORY Not Transferable				
Prerequisite: MTT 57 and MTT 59 with grades of "C" or higher or "Pass."				
22309	5:30-8:20PM	M	Vo,C	ME 3H
MTT 100 - 2.0 UNITS MACHINE TOOL INTRODUCTION Transferable to CSU				
28654	5:30-6:30PM	Th	Vo,C	ME 2J
	6:30-9:20PM	Th	Vo,C	ME 2J
26306	8:00-9:07AM	Sat	Arias,R	ME 3H
	9:07-12:20PM	Sat	Arias,R	ME 3H
Class# 26306 meets 01/18/2020-05/16/2020				
MTT 180 - 3.0 UNITS ROBOTICS FOR COMPUTER NUMERICALLY CONTROLLED MACHINES Transferable to CSU				
25647	4:00-6:00PM	W	Vo,C	ME 3H
	6:00-8:50PM	W	Vo,C	ME 3H
MTT 278 - 3.5 UNITS MASTERCAM ADVANCED Transferable to CSU				
Prerequisite: MTT 51 or equivalent with a grade of "C" or higher or "Pass", or appropriate work experience.				
26962	5:30-8:30PM	Th	Barnes,J	ME 3H
	8:30-9:45PM	Th	Barnes,J	ME 3H

Students not in attendance or late for the first class meeting are subject to drop.

MATHEMATICS

Cerritos College Mathematics Department Sequence of Courses

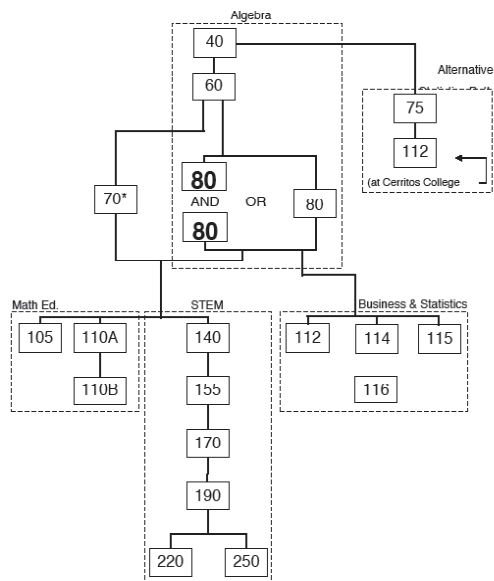

**Although MATH 70 is not a prerequisite for MATH 115 or MATH 116, it is recommended.*

MATH 5 - 1.0 UNIT MATHEMATICS LEARNING STRATEGIES

Not Transferable

29077	8:30-9:20PM	M	Tran,L	MCIS105
Students enrolled in this class must also enroll in Math 112 (20517)				
29078	4:00-4:50PM	T	Yi,P	MCIS105
Students enrolled in this class must also enroll in Math 112 (20516)				
29079	12:30-1:20PM	M	Lewandowski,T	MCIS105
Students enrolled in this class must also enroll in Math 140 (22576)				
30022	10:00-10:50AM	T	McCance,I	MCIS105
Students enrolled in this class must also enroll in Math 140 (27809)				
30023	8:00-8:50PM	M	O'Neil,S	PST234
Students enrolled in this class must also enroll in Math 112 (29683)				
30024	9:00-9:50AM	T	Bonakdar,M	MCIS109
Students enrolled in this class must also enroll in Math 140 (20533)				
30025	8:30-9:20PM	T	STAFF	MCIS109
Students enrolled in this class must also enroll in Math 140 (20536)				
30026	9:00-9:50AM	M	STAFF	MCIS113
Students enrolled in this class must also enroll in Math 140 (20930)				
30027	8:00-8:50PM	T	Cedeno,J	PST237
Students enrolled in this class must also enroll in Math 140 (27385)				
30028	5:00-5:50PM	M	Tran,L	MCIS110
Students enrolled in this class must also enroll in Math 112 (24161)				
30029	3:00-3:50PM	T	O'Neil,S	MCIS113
Students enrolled in this class must also enroll in Math 112 (28702)				
30030	10:00-10:50AM	T	Cortez,D	PST233
Students enrolled in this class must also enroll in Math 112 (28703)				
30031	1:00-1:50PM	M	Mariani,I	PST233
Students enrolled in this class must also enroll in Math 112 (28223)				
30032	4:00-4:50PM	M	Conley,A	MCIS208
Students enrolled in this class must also enroll in Math 112 (29052)				
30033	9:00-9:50AM	M	Calisher,J	PST233
Students enrolled in this class must also enroll in Math 114 (22987)				
30034	1:00-1:50PM	T	Ortiz,L	PST233
Students enrolled in this class must also enroll in Math 114 (20526)				
30036	7:00-7:50PM	M	Takeuchi,K	PST233
Students enrolled in this class must also enroll in Math 114 (29684)				
30037	7:00-7:50PM	T	Ortiz,L	PST233
Students enrolled in this class must also enroll in Math 114 (30053)				
30038	10:00-10:50AM	M	Cortez,D	PST234
Students enrolled in this class must also enroll in Math 112 (29056)				
30039	10:00-10:50AM	T	Morales,M	PST234
Students enrolled in this class must also enroll in Math 112 (28130)				

30040	3:00-3:50PM	M	O'Neil,S	PST234
Students enrolled in this class must also enroll in Math 112 (28131)				
30041	3:00-3:50PM	T	Flores,W	PST234
Students enrolled in this class must also enroll in Math 112 (27420)				
30042	8:00-8:50PM	T	Niu,K	PST234
Students enrolled in this class must also enroll in Math 112 (30055)				
30043	10:00-10:50AM	M	Nikdel,M	PST235
Students enrolled in this class must also enroll in Math 112 (30066)				
30045	7:00-7:50PM	M	Ojose,B	PST235
Students enrolled in this class must also enroll in Math 112 (30068)				
30046	7:00-7:50PM	T	Tran,T	PST235
Students enrolled in this class must also enroll in Math 112 (30069)				
30021	2:30-3:20PM	TTh	McCance,I	PST237
Students enrolled in this class must also enroll in Math 140 (30010)				
Class# 30021 meets 01/13/2020-03/12/2020				

MATH 40 - 4.0 UNITS PREALGEBRA

Not Transferable

Prerequisite: MATH 20 or equivalent with a grade of "C" or higher or "Pass" or completion of the math placement process with a score eligible for MATH 40.

26262	12:30-2:20PM	TTh	Worrel,D	LC209
*(SEMI-INDEP SECT - LC209)				
This math 40 course is a semi-independent course. For more information, please visit www.cerritos.edu/MLC				
26263	6:00-7:50PM	TTh	Campeau,L	LC209
*(SEMI-INDEP SECT - LC209)				
This math 40 course is a semi-independent course. For more information, please visit www.cerritos.edu/MLC				
26264	6:00-7:50PM	MW	Worrel,D	LC209
*(SEMI-INDEP SECT - LC209)				
This math 40 course is a semi-independent course. For more information, please visit www.cerritos.edu/MLC				
26265	10:00-11:50AM	MW	Campeau,L	LC209
*(SEMI-INDEP SECT - LC209)				
This math 40 course is a semi-independent course. For more information, please visit www.cerritos.edu/MLC				
20461	12:00-1:50PM	MW	Campeau,L	LC209
*(SEMI-INDEP SECT - LC209)				
This math 40 course is a semi-independent course. For more information, please visit www.cerritos.edu/MLC				
20465	7:00-8:50AM	MW	Beyene,A	MCIS110
20466	8:00-9:50PM	TTh	Daige,M	MCIS113
22221	9:00-10:50AM	MTWTh	Lewandowski,T	MCIS104
Students enrolled in this class will have the opportunity to enroll in Math 60 (22913) during the second 9-week session				
Class# 22221 meets 01/13/2020-03/12/2020				
22261	6:00-7:50PM	MTWTh	Gonzales,A	MCIS107
Students enrolled in this class will have the opportunity to enroll in Math 60 (26270) during the second 9-week session				
Class# 22261 meets 01/13/2020-03/12/2020				
MATH 60 - 4.0 UNITS ELEMENTARY ALGEBRA				
Not Transferable				
Prerequisite: MATH 40 or equivalent with a grade of "C" or higher or "Pass" or completion of the math placement process with a score eligible for MATH 60.				
Recommendation: Meet the prerequisite within two years prior to the date of enrollment in MATH 60.				
28195	7:00-8:50AM	TTh	Budarin,D	MCIS106
20473	8:00-9:50PM	MW	STAFF	MCIS113
27838	9:00-10:50AM	TTh	Worrel,D	LC209
*(SEMI-INDEP SECT - LC209)				
This math 60 course is a semi-independent course. For more information, please visit www.cerritos.edu/MLC .				
27839	12:30-2:20PM	TTh	Worrel,D	LC209
*(SEMI-INDEP SECT - LC209)				
This math 60 course is a semi-independent course. For more information, please visit www.cerritos.edu/MLC .				
27840	10:00-11:50AM	MW	Campeau,L	LC209
*(SEMI-INDEP SECT - LC209)				
This math 60 course is a semi-independent course. For more information, please visit www.cerritos.edu/MLC .				
27841	6:00-7:50PM	MW	Worrel,D	LC209
*(SEMI-INDEP SECT - LC209)				
This math 60 course is a semi-independent course. For more information, please visit www.cerritos.edu/MLC .				
27842	6:00-7:50PM	TTh	Campeau,L	LC209
*(SEMI-INDEP SECT - LC209)				
This math 60 course is a semi-independent course. For more information, please visit www.cerritos.edu/MLC .				

Class#	Time	Day	Instructor	Room	Class#	Time	Day	Instructor	Room
27843	12:00-1:50PM	MW	Campeau,L	LC209	27844	10:00-11:50AM	MW	Campeau,L	LC209
	*(SEMI-INDEP SECT - LC209) This math 60 course is a semi-independent course. For more information, please visit www.cerritos.edu/MLC .					*(SEMI-INDEP SECT - LC209) This math 80 course is a semi-independent course. For more information, please visit www.cerritos.edu/MLC .			
22575	11:00-12:50PM	MTWTh	STAFF	MCIS106	27845	12:00-1:50PM	MW	Campeau,L	LC209
	Students enrolled in this class will have the opportunity to enroll in Math 80 (20501) during the second 9-week session Class# 22575 meets 01/13/2020-03/12/2020					*(SEMI-INDEP SECT - LC209) This math 80 course is a semi-independent course. For more information, please visit www.cerritos.edu/MLC .			
26270	6:00-7:50PM	MTWTh	STAFF	MCIS107	27846	9:00-10:50AM	TTh	Worrel,D	LC209
	Class# 26270 meets 03/23/2020-05/21/2020					*(SEMI-INDEP SECT - LC209) This math 80 course is a semi-independent course. For more information, please visit www.cerritos.edu/MLC .			
22913	9:00-10:50AM	MTWTh	Lewandowsky,T	MCIS104	27847	12:30-2:20PM	TTh	Worrel,D	LC209
	Class# 22913 meets 03/23/2020-05/21/2020					*(SEMI-INDEP SECT - LC209) This math 80 course is a semi-independent course. For more information, please visit www.cerritos.edu/MLC .			
MATH 70 - 4.0 UNITS PLANE GEOMETRY					27848 6:00-7:50PM TTh Campeau,L LC209				
Not Transferable					*(SEMI-INDEP SECT - LC209) This math 80 course is a semi-independent course. For more information, please visit www.cerritos.edu/MLC .				
Prerequisite: MATH 60 or equivalent with a grade of "C" or higher or "Pass" or completion of the math placement process with a score eligible for MATH 70.					27849 6:00-7:50PM MW Worrel,D LC209				
20489	11:00-12:50PM	MW	STAFF	PST235	*(SEMI-INDEP SECT - LC209) This math 80 course is a semi-independent course. For more information, please visit www.cerritos.edu/MLC .				
20910	7:00-8:50PM	TTh	STAFF	MCIS105	26272 9:00-10:50AM MTWTh STAFF MCIS106				
22220	1:00-2:50PM	MTWTh	STAFF	MCIS106	Students enrolled in this class will have the opportunity to enroll in Math 140 (30008) during the second 9-week session Class# 26272 meets 01/13/2020-03/12/2020				
Students enrolled in this class will have the opportunity to enroll in Math 140 (29685) during the second 9-week session Class# 22220 meets 01/13/2020-03/12/2020					20500 2:00-3:50PM MTWTh Beyene,A MCIS107				
27807	5:00-6:50PM	MTWTh	STAFF	MCIS106	Students enrolled in this class will have the opportunity to enroll in Math 140 (30009) during the second 9-week session Class# 20500 meets 01/13/2020-03/12/2020				
Students enrolled in this class will have the opportunity to enroll in Math 80 (28698) during the second 9-week session Class# 27807 meets 01/13/2020-03/12/2020					26812 12:00-1:50PM MTWTh STAFF MCIS107				
MATH 75 - 6.0 UNITS MATHEMATICAL LITERACY FOR COLLEGE STUDENTS					Students enrolled in this class will have the opportunity to enroll in Math 112 (29226) during the second 9-week session Class# 26812 meets 01/13/2020-03/12/2020				
Not Transferable					25810 4:00-5:50PM MTWTh STAFF MCIS107				
Prerequisite: MATH 40 or equivalent with a grade of "C" or higher or "Pass" or completion of the math placement process with a score eligible for MATH 60.					Students enrolled in this class will have the opportunity to enroll in Math 114 (30140) during the second 9-week session Class# 25810 meets 01/13/2020-03/12/2020				
Recommendation: MATH 40 with a grade of "C" or higher or "Pass" within two years prior to enrollment in MATH 75.					20501 11:00-12:50PM MTWTh STAFF MCIS104				
26121	11:00-1:50PM	TTh	Ngo,H	MCIS105	Class# 20501 meets 03/23/2020-05/21/2020				
26122	1:30-4:20PM	MW	STAFF	MCIS105	28698 5:00-6:50PM MTWTh STAFF MCIS106				
30071	7:00-9:50PM	MW	STAFF	PST237	Class# 28698 meets 03/23/2020-05/21/2020				
26931	4:00-6:50PM	TTh	Mariani,I	MCIS111	MATH 80A - 3.0 UNITS INTERMEDIATE ALGEBRA I				
27219	8:00-10:50AM	MW	STAFF	PST237	Not Transferable				
					Prerequisite: MATH 60 or equivalent with a grade of "C" or higher or "Pass" or completion of the math placement process with a score eligible for MATH 80A. Recommendation: Meet the prerequisite within two years prior to the date of enrollment in MATH 80A.				
					26278 10:00-11:15AM MW Campeau,L LC209				
					*(SEMI-INDEP SECT - LC209) This math 80A course is a semi-independent course. For more information, please visit www.cerritos.edu/MLC .				
					26279 12:00-1:15PM MW Campeau,L LC209				
					*(SEMI-INDEP SECT - LC209) This math 80A course is a semi-independent course. For more information, please visit www.cerritos.edu/MLC .				
					26280 9:00-10:15AM TTh Worrel,D LC209				
					*(SEMI-INDEP SECT - LC209) This math 80A course is a semi-independent course. For more information, please visit www.cerritos.edu/MLC .				
					26281 12:30-1:45PM TTh Worrel,D LC209				
					*(SEMI-INDEP SECT - LC209) This math 80A course is a semi-independent course. For more information, please visit www.cerritos.edu/MLC .				
					26282 6:00-7:15PM MW Worrel,D LC209				
					*(SEMI-INDEP SECT - LC209) This math 80A course is a semi-independent course. For more information, please visit www.cerritos.edu/MLC .				
					30072 6:00-7:15PM TTh Campeau,L LC209				
					*(SEMI-INDEP SECT - LC209)				
MATH 80 - 4.0 UNITS INTERMEDIATE ALGEBRA									
Not Transferable									
Prerequisite: MATH 60 or equivalent with a grade of "C" or higher or "Pass" or completion of the math placement process with a score eligible for MATH 80.									
Recommendation: Meet the prerequisite within two years prior to the date of enrollment in MATH 80.									
20493	4:30-6:20PM	MW	Pallwitz,K	MCIS105					
20494	5:00-6:50PM	TTh	Trinh,T	MCIS110					
20496	10:00-11:50AM	MW	STAFF	MCIS107					
28704	8:00-9:50PM	MW	Beyene,A	MCIS107					
22979	11:00-12:50PM	TTh	Murugugh,Y	MCIS108					
28194	3:00-4:50PM	MW	Worrel,D	MCIS108					
28705	3:00-4:50PM	TTh	Trihn,T	MCIS108					
20912	8:00-9:50PM	MW	Ojose,B	MCIS110					



**CERRITOS COLLEGE
SUCCESS CENTER**

Walk-In Math Tutoring

Monday – Thursday: 9 am – 9 pm
Friday: 10 am – 2 pm
Saturday: 10 am – 3 pm

Math Tutoring Appointments now available!
Visit the Success Center Reception Desk to schedule yours today!

All students should have a Cerritos College ID Card with the current semester sticker.

Hours and staffing may be subject to change, call the Math Success Center at (562) 653-7891 for more information.

Students not in attendance or late for the first class meeting are subject to drop.

Class#	Time	Day	Instructor	Room	Class#	Time	Day	Instructor	Room
MATH 80B - 3.0 UNITS INTERMEDIATE ALGEBRA II									
Not Transferable									
Prerequisite: MATH 80A or equivalent with a grade of "C" or higher or "Pass."									
26287	12:30-1:45PM	TTh	Worrel,D	LC209	29056	8:00-9:50AM	MW	Cortez,D	PST234
*(SEMI-INDEP SECT - LC209)					Students enrolled in this class must also enroll in Math 5 (30038)				
This math 80B course is a semi-independent course. For more information, please visit www.cerritos.edu/MLC.									
26283	10:00-11:15AM	MW	Campeau,L	LC209	29683	6:00-7:50PM	MW	O'Neil,S	PST234
*(SEMI-INDEP SECT - LC209)					Students enrolled in this class must also enroll in Math 5 (30023)				
This math 80B course is a semi-independent course. For more information, please visit www.cerritos.edu/MLC.									
26284	12:00-1:15PM	MW	Campeau,L	LC209	30055	6:00-7:50PM	TTh	Nui,K	PST234
*(SEMI-INDEP SECT - LC209)					Students enrolled in this class must also enroll in Math 5 (30042)				
This math 80B course is a semi-independent course. For more information, please visit www.cerritos.edu/MLC.									
26285	9:00-10:15AM	TTh	Worrel,D	LC209	30056	11:00-12:50PM	MW	Conley,A	MCIS208
*(SEMI-INDEP SECT - LC209)					30057	11:00-12:50PM	TTh	Sarvi,K	PST234
This math 80B course is a semi-independent course. For more information, please visit www.cerritos.edu/MLC.					30058	9:00-10:50PM	MW	STAFF	MCIS105
26286	6:00-7:15PM	TTh	Campeau,L	LC209	30059	11:00-12:50PM	TTh	STAFF	PST235
*(SEMI-INDEP SECT - LC209)					30060	1:00-2:50PM	MW	Chalmers,G	PST235
This math 80B course is a semi-independent course. For more information, please visit www.cerritos.edu/MLC.					30061	12:00-2:20PM	TTh	STAFF	MCIS109
30073	6:00-7:15PM	MW	Worrel,D	LC209	30062	3:00-4:50PM	MW	Aguilar-Bastida,R	PST235
*(SEMI-INDEP SECT - LC209)					30063	3:00-4:50PM	TTh	Valentine,M	PST235
MATH 110B - 3.0 UNITS MATHEMATICS FOR ELEMENTARY TEACHERS					30064	8:00-9:50PM	MW	Igolnikov,M	PST235
Transferable to UC, CSU					30065	8:00-9:50PM	TTh	Tran,T	PST235
Prerequisite: MATH 110A or equivalent with a grade of "C" or higher or "Pass."					30066	8:00-9:50AM	MW	Nikdel,M	PST235
A graphing calculator is required for this course. A Texas Instruments 84, or 84+, is strongly recommended.					Students enrolled in this class must also enroll in Math 5 (30043)				
30019	4:00-5:30PM	MW	Perez,L	PST234	30067	8:00-9:50AM	TTh	Ninh,J	MCIS107
	5:30-5:50PM	MW	Perez,L	PST234	30068	5:00-6:50PM	MW	STAFF	PST235
MATH 112 - 4.0 UNITS ELEMENTARY STATISTICS					Students enrolled in this class must also enroll in Math 5 (30045)				
Transferable to UC, CSU (CAN STAT 2)									
Prerequisite: Math 80 or Math 80B or Math 75 or equivalent with a grade of "C" or "Pass" or higher or satisfactory completion of the math assessment/ placement process with eligibility for Math 112.									
A graphing calculator is required for this course. A Texas Instruments 84, or 84+, is strongly recommended.									
20516	2:00-3:50PM	TTh	Yi,P	MCIS105	30069	5:00-6:50PM	TTh	Tran,T	PST235
Students enrolled in this class must also enroll in Math 5 (29078)					Students enrolled in this class must also enroll in Math 5 (30046)				
20517	6:30-8:20PM	MW	Tran,L	MCIS105	29226	12:00-1:50PM	MTWTh	STAFF	MCIS107
Students enrolled in this class must also enroll in Math 5 (29077)					Class# 29226 meets 03/23/2020-05/21/2020				
22984	5:00-6:50PM	TTh	Yi,P	MCIS105	MATH 114 - 4.0 UNITS COLLEGE ALGEBRA				
20519	10:00-11:50AM	TTh	Ninh,J	MCIS107	Transferable to UC, CSU				
20520	8:00-9:50PM	TTh	Conley,A	MCIS107	Prerequisite: MATH 80 or MATH 80B or equivalent with a grade of "C" or higher or "Pass" or completion of the math placement process with a score eligible for MATH courses 100 level or higher.				
20521	7:00-8:50AM	MW	Budarin,D	MCIS106	A graphing calculator is required for this course. A Texas Instruments 84, or 84+, is strongly recommended.				
27808	9:00-10:50AM	TTh	Pham,M	MCIS108	20522	1:00-2:50PM	TTh	Torres,M	MCIS108
20923	11:00-12:50PM	MW	Morales,M	MCIS108	Students enrolled in this class must also enroll in Math 5 (30035)				
20924	2:00-3:50PM	TTh	Sarvi,K	MCIS108	26288	12:00-1:50PM	MW	Campeau,L	LC209
22219	1:00-2:50PM	MW	Nguimdjou,E	MCIS108	*(SEMI-INDEP SECT - LC209)				
28700	5:00-6:50PM	TTh	Bateman,M	MCIS108	This math 114 course is a semi-independent course. For more information, please visit www.cerritos.edu/MLC.				
24160	7:00-8:50PM	MW	Huang,F	MCIS108	26289	6:00-7:50PM	TTh	Campeau,L	LC209
24161	3:00-4:50PM	MW	Tran,L	MCIS110	*(SEMI-INDEP SECT - LC209)				
Students enrolled in this class must also enroll in Math 5 (30028)					This math 114 course is a semi-independent course. For more information, please visit www.cerritos.edu/MLC				
24163	7:00-8:50AM	TTh	Nikdel,M	MCIS113	26290	6:00-7:50PM	MW	Worrel,D	LC209
26123	12:00-1:50PM	MW	STAFF	MCIS113	*(SEMI-INDEP SECT - LC209)				
26124	4:00-5:50PM	MW	O'Neil,S	MCIS113	This math 114 course is a semi-independent course. For more information, please visit www.cerritos.edu/MLC				
27420	1:00-2:50PM	TTh	Flores,W	PST234	20526	11:00-12:50PM	TTh	Ortiz,L	PST233
Students enrolled in this class must also enroll in Math 5 (30041)					Students enrolled in this class must also enroll in Math 5 (30034)				
28079	4.0 HRS ARR	(OL)	Nikdel,M	ONLINE	20527	7:00-8:50AM	TTh	Calisher,J	MCIS108
28130	8:00-9:50AM	TTh	Morales,M	PST234	26291	9:00-10:50AM	TTh	Worrel,D	LC209
Students enrolled in this class must also enroll in Math 5 (30039)					*(SEMI-INDEP SECT - LC209)				
28131	1:00-2:50PM	MW	O'Neil,S	PST234	This math 114 course is a semi-independent course. For more information, please visit www.cerritos.edu/MLC.				
Students enrolled in this class must also enroll in Math 5 (30040)					22986	9:00-10:50AM	MW	Torrez,M	MCIS108
28223	11:00-12:50PM	MW	STAFF	PST233	20927	5:00-6:50PM	MW	Byun,E	MCIS108
Students enrolled in this class must also enroll in Math 5 (30031)					21970	7:00-8:50PM	TTh	Bateman,M	MCIS108
28701	4:00-5:50PM	TTh	Nui,K	MCIS113	22456	1:00-2:50PM	MW	STAFF	MCIS110
28702	1:00-2:50PM	TTh	O'Neil,S	MCIS113	27246	3:00-4:50PM	TTh	Byun,E	MCIS110
Students enrolled in this class must also enroll in Math 5 (30029)					22987	7:00-8:50AM	MW	Calisher,J	PST233
28703	8:00-9:50AM	TTh	Cortez,D	PST233	Students enrolled in this class must also enroll in Math 5 (30033)				
Students enrolled in this class must also enroll in Math 5 (30030)					29050	4.0 HRS ARR	(OL)	Byun,E	ONLINE
29025	4.0 HRS ARR	(OL)	Conley,A	ONLINE	29684	5:00-6:50PM	MW	Takeuchi,K	PST233
29045	4.0 HRS ARR	(OL)	Mariani,I	ONLINE	Students enrolled in this class must also enroll in Math 5 (30036)				
29052	2:00-3:50PM	MW	STAFF	MCIS208	30053	5:00-6:50PM	TTh	Ortiz,L	PST233
Students enrolled in this class must also enroll in Math 5 (30032)					Students enrolled in this class must also enroll in Math 5 (30037)				
					27084	4.0 HRS ARR	(OL)	Beyene,A	ONLINE
					Class# 27084 meets 02/03/2020-05/22/2020				
					29024	4.0 HRS ARR	(OL)	Calisher,J	ONLINE
					Class# 29024 meets 02/03/2020-05/22/2020				
					21561	3:00-4:50PM	MTWTh	STAFF	MCIS106
					Students enrolled in this class will have the opportunity to enroll in Math 116 (30054) during the second 9-week session				
					Class# 21561 meets 01/13/2020-03/12/2020				
					30140	4:00-5:50PM	MTWTh	STAFF	MCIS107
					Class# 30140 meets 03/23/2020-05/21/2020				

Students not in attendance or late for the first class meeting are subject to drop.

Class#	Time	Day	Instructor	Room	Class#	Time	Day	Instructor	Room
MATH 116 - 4.0 UNITS CALCULUS FOR MANAGERIAL, BIOLOGICAL AND SOCIAL SCIENCES Transferable to UC, CSU (CAN MATH 34) Prerequisite: MATH 114 or equivalent with a grade of "C" or higher or "Pass" or completion of the math placement process with a score eligible for MATH 116. 20529 11:00-12:50PM TTh STAFF MCIS110 A graphing calculator is required for this course. A Texas Instruments 84, or 84+, is strongly recommended.					27190 8:00-10:15AM MW STAFF MCIS109 27191 7:00-9:15PM MW Byun,E MCIS109 27192 10:00-12:15PM TTh Flores,W MCIS109 27193 4:30-6:45PM TTh George,P MCIS109 27220 8:00-10:15AM MW Cho,A MCIS111 27810 8:00-10:15AM TTh Cho,A MCIS111 30048 1:30-3:45PM MW Cortez,D MCIS111 30047 1:00-3:15PM MTWTh McCance,I PST237 Class# 30047 meets 03/23/2020-05/21/2020				
20928 10:00-11:50AM MW Calisher,J MCIS113 22988 2:00-3:50PM MW Takeuchi,K MCIS113 30051 6:00-7:50PM TTh Daigle,M MCIS113 30054 3:00-4:50PM MTWTh STAFF MCIS106 Class# 30054 meets 03/23/2020-05/21/2020					MATH 170 - 4.0 UNITS ANALYTIC GEOMETRY AND CALCULUS I Transferable to UC, CSU (CAN MATH 18)(CAN MATH SEQ C) Prerequisite: MATH 150 or MATH 155 or equivalent with a grade of "C" or higher or "Pass" or completion of the math placement process with a score eligible for MATH 170. A graphing calculator is required for this course. A Texas Instruments 84, or 84+, is strongly recommended.				
MATH 140 - 3.0 UNITS TRIGONOMETRY Transferable to CSU (CAN MATH 8) Prerequisite: MATH 80 or MATH 80B or equivalent with a grade of "C" or higher or "Pass" or completion of the math placement process with a score eligible for MATH courses numbered 100 level or higher and MATH 70 or equivalent with a grade of "C" or higher or "Pass." A graphing calculator is required for this course. A Texas Instruments 84, or 84+, is strongly recommended.					20539 3:00-4:50PM MW George,P MCIS109 22990 9:00-10:50AM TTh Nikdel,M MCIS110 20933 11:00-12:50PM MW Byun,E MCIS110 20934 1:00-2:50PM TTh George,P MCIS110 21575 7:00-8:50PM TTh Trinh,T MCIS110 30052 6:00-7:50PM MW Aguilar-Bastida,R MCIS113 22461 4:00-5:50PM MTWTh Lopez,M PST237 Students enrolled in this class will have the opportunity to enroll in Math 190 (30049) during the second 9-week session Class# 22461 meets 01/13/2020-03/12/2020				
22576 11:00-12:15PM MW Lewandowski,T MCIS105 Students enrolled in this class must also enroll in Math 5 (29079)					MATH 190 - 4.0 UNITS ANALYTIC GEOMETRY AND CALCULUS II Transferable to UC, CSU (CAN MATH 20)(CAN MATH SEQ C) Prerequisite: MATH 170 or equivalent with a grade of "C" or higher or "Pass." A graphing calculator is required for this course. A Texas Instruments 84, or 84+, is strongly recommended.				
27809 8:30-9:45AM TTh McCance,I MCIS105 Students enrolled in this class must also enroll in Math 5 (30022)					22991 9:00-10:50AM MW Morales,M MCIS110 20540 6:00-7:50PM MW Igolnikov,M MCIS110 20935 9:00-10:50AM TTh Lewandowski,P PST235 22431 2:30-4:20PM TTh Leon,R MCIS109 30141 5:00-6:50PM MW STAFF MCIS109 30049 4:00-5:50PM MTWTh Lopez,M PST237 Class# 30049 meets 03/23/2020-05/21/2020				
20533 7:30-8:45AM TTh Banahdar,M MCIS109 Students enrolled in this class must also enroll in Math 5 (30024)					MATH 225 - 5.0 UNITS CALCULUS III Transferable to UC, CSU Prerequisite: MATH 190 or equivalent with a grade of "C" or higher or "Pass." A graphing calculator is required for this course. A Texas Instruments 84, or 84+, is strongly recommended.				
26292 10:00-11:15AM MW Campeau,L LC209 *(SEMI-INDEP SECT - LC209) This math 140 course is a semi-independent course. For more information, please visit www.cerritos.edu/MLC.					27877 1:30-3:45PM TTh Conley,A MCIS111 27878 7:00-9:15PM MW Leon,R MCIS111 30070 8:00-10:15AM TTh Hultman,J PST237				
26293 9:00-10:15AM TTh Worrel,D LC209 *(SEMI-INDEP SECT - LC209) This math 140 course is a semi-independent course. For more information, please visit www.cerritos.edu/MLC.					MATH 250 - 5.0 UNITS LINEAR ALGEBRA AND DIFFERENTIAL EQUATIONS Transferable to UC, CSU Prerequisite: MATH 190 or equivalent with a grade of "C" or higher or "Pass." Recommendation: MATH 220 or MATH 225 or equivalent with a grade of "C" or higher or "Pass." A graphing calculator is required for this course. A Texas Instruments 84, or 84+, is strongly recommended.				
20536 7:00-8:15PM TTh STAFF MCIS109 Students enrolled in this class must also enroll in Math 5 (30025)					24162 10:30-12:45PM MW Chalmers,G MCIS109 30050 7:00-9:15PM TTh Leon,R MCIS111				
26294 12:30-1:45PM TTh Worrel,D LC209 *(SEMI-INDEP SECT - LC209) This math 140 course is a semi-independent course. For more information, please visit www.cerritos.edu/MLC.					MATH 60 - 2.0 UNITS INTRODUCTION TO MEDICAL ASSISTING Not Transferable 27080 12:00-1:50PM M STAFF SL105				
20930 7:30-8:45AM MW STAFF MCIS113 Students enrolled in this class must also enroll in Math 5 (30026)					MATH 63 - 3.0 UNITS HEALTH INSURANCE CODING AND BILLING Not Transferable Recommendation: MA 161 or equivalent with a grade of "C" or higher or "Pass." 29554 9:00-11:50AM F STAFF SL105				
26295 6:00-7:15PM MW Worrel,D LC209 *(SEMI-INDEP SECT - LC209) This math 140 course is a semi-independent course. For more information, please visit www.cerritos.edu/MLC.									
26296 6:00-7:15PM TTh Campeau,L LC209 *(SEMI-INDEP SECT - LC209) This math 140 course is a semi-independent course. For more information, please visit www.cerritos.edu/MLC.									
27385 6:30-7:45PM TTh STAFF PST237 Students enrolled in this class must also enroll in Math 5 (30027)									
30011 1:00-2:15PM MW STAFF MCIS109									
30012 1:00-2:15PM TTh Lewandowski,P PST235									
30013 10:30-11:45AM MW Cho,A MCIS111									
30014 12:00-1:15PM MW Cho,A MCIS111									
30015 10:30-11:45AM TTh Pham,A MCIS111									
30016 12:00-1:15PM TTh Pham,A MCIS111									
30017 4:00-5:15PM MW Leon,R MCIS111									
30018 5:30-6:45PM MW Morales,M MCIS111									
30009 2:00-3:15PM MTWTh STAFF MCIS107 Class# 30009 meets 03/23/2020-05/21/2020									
30010 1:00-2:15PM MTWTh McCance,I PST237 Students enrolled in this class must also enroll in Math 5 (30021). Students enrolled in this class will have the opportunity to enroll in Math 155 (30047) during the second 9-week session Class# 30010 meets 01/13/2020-03/12/2020									
29685 1:00-2:15PM MTWTh STAFF MCIS106 Class# 29685 meets 03/23/2020-05/21/2020									
30008 9:00-10:15AM MTWTh Budarin,D MCIS106 Class# 30008 meets 03/23/2020-05/21/2020									
MATH 155 - 5.0 UNITS PRECALCULUS Transferable to CSU Prerequisite: MATH 140 or equivalent with a grade of "C" or higher or "Pass" or completion of the math placement process with a score eligible for MATH 155. A graphing calculator is required for this course. A Texas Instruments 84, or 84+, is strongly recommended.									

MEDICAL ASSISTANT

Additional MEDICAL ASSISTING DEPARTMENT courses are listed under Health Occupations (HO 53, HO 54, and HO 55).
Clearance of a criminal background check and/or drug abuse testing may be required prior to clinical field experience.

Students not in attendance or late for the first class meeting are subject to drop.

Class#	Time	Day	Instructor	Room	Class#	Time	Day	Instructor	Room
MA 64 - 3.0 UNITS MEDICAL OFFICE ASSISTING									
Not Transferable									
27082	9:00-11:00AM	W	STAFF	SL105					
	11:00-1:50PM	W	STAFF	SL105					
MA 66 - 3.0 UNITS MEDICATIONS AND SPECIALTIES									
Not Transferable									
20900	5:00-7:00PM	Th	STAFF	SL105					
	7:00-9:50PM	Th	STAFF	SL105					
MA 67 - 3.0 UNITS MEDICAL OFFICE ADMINISTRATION									
Not Transferable									
Prerequisite: MA 60.									
Recommendation: BCOT 62 and BCOT 3T or equivalent with grades of Pass or "C" or higher.									
20454	5:00-7:50PM	T	STAFF	SL105					
MA 68 - 4.0 UNITS MEDICAL ASSISTING INTERNSHIP EXPERIENCE									
Not Transferable									
Prerequisite: MA 60, MA 62A and MA 62B or MA 63, and MA 64, MA 161, HO 53, HO 54, HO 55 or equivalent with grades of "C" or higher or "Pass."									
Corequisite: MA 66 and MA 67 or prior completion with a grade of "Pass" or "C" or higher.									
20455	4:00-4:50PM	Th	STAFF	SL105					
	+10.0 HRS ARR		STAFF						
MA 73 - 3.0 UNITS MEDICAL ASSISTANT OCCUPATIONAL WORK EXPERIENCE									
Not Transferable									
Prerequisite: MA 60, MA 62A and MA 62B or MA 63, and MA 64, MA 161, HO 53, HO 54, HO 55 or equivalent with grades of "C" or higher or "Pass."									
Corequisite: MA 66 and MA 67 or prior completion with a grade of "Pass" or "C" or higher.									
29555	4:00- 4:50PM	Th	STAFF	SL105					
MA 74 - 4.0 UNITS MEDICAL ASSISTANT OCCUPATIONAL WORK EXPERIENCE									
Not Transferable									
Prerequisite: MA 60, MA 62A and MA 62B or MA 63, and MA 64, MA 161, HO 53, HO 54, HO 55 or equivalent with grades of "C" or higher or "Pass."									
Corequisite: MA 66 and MA 67 or prior completion with a grade of "Pass" or "C" or higher.									
29556	4:00- 4:50PM	Th	STAFF	SL105					
MA 161 - 3.0 UNITS MEDICAL TERMINOLOGY									
Transferable to CSU									
20456	9:00-11:50AM	M	STAFF	SL109					
20902	7:00-9:50PM	W	STAFF	HS305					
23290	3.0 HRS ARR	(OL)	STAFF	ONLINE					
21055	3.0 HRS ARR	(OL)	STAFF	ONLINE					

MUSIC									
MUS 100 - 3.0 UNITS MUSIC APPRECIATION									
Transferable to UC, CSU									
22250	9:30-12:20PM	F	Lee,S						BC 53
23579	11:00-12:20PM	TTh	Dimond,T						BC 53
27851	3.0 HRS ARR	(OL)	Pacier,P						ONLINE
MUS 101 - 3.0 UNITS INTRODUCTION TO WORLD MUSIC									
Transferable to UC, CSU									
20544	3.0 HRS ARR		Pacier,P			(OL)			ONLINE
MUS 104B - 3.0 UNITS HISTORY OF ROCK MUSIC									
Transferable to UC, CSU									
20545	7:00-9:50PM	Th	Carroll II,D						FA133,FA134
21593	3.0 HRS ARR	(OL)	Simmons,J						ONLINE
22880	6.0 HRS ARR	(OL)	Simmons,J						ONLINE
Class# 22880 meets 03/23/2020-05/20/2020									
MUS 105 - 3.0 UNITS MUSIC FUNDAMENTALS									
Transferable to UC, CSU									
22243	11:00-12:20PM	MW	DeMichele,A						BC 68
22244	2:00-3:20PM	MW	Tsai,S						BC 68
22246	8:00-9:20AM	TTh	Tsai,S						BC 51
22248	2:00-3:20PM	TTh	Da Silva,P						BC 68
29225	3.0 HRS ARR	(OL)	Betancourt,D						ONLINE
30279	3.0 HRS ARR	(OL)	Betancourt,D						ONLINE
MUS 112 - 2.0 UNITS ELEMENTARY PIANO I									
Transferable to UC, CSU (CAN MUS 22)									
20547	11:00-11:50AM	TTh	Lee,S						BC 68
	11:50-12:20PM	TTh	Lee,S						BC 68
25792	9:30-10:30AM	TTh	Lopez,C						BC 68
	10:30-10:50AM	TTh	Lopez,C						BC 68
21594	6:30-8:30PM	Th	Chen,J						BC 68
	8:30-9:20PM	Th	Chen,J						BC 68
21793	12:30-1:30PM	MW	Lopez,C						BC 68
	1:30-1:50PM	MW	Lopez,C						BC 68
MUS 113 - 2.0 UNITS ELEMENTARY PIANO II									
Transferable to UC, CSU (CAN MUS 24)									
Prerequisite: MUS 112 or equivalent with a grade of "C" or higher or "Pass".									
21596	6:30-8:30PM	Th	Chen,J						BC 68
	8:30-9:20PM	Th	Chen,J						BC 68
21600	9:30-10:30AM	MW	Lopez,C						BC 68
	10:30-10:50AM	MW	Lopez,C						BC 68
29088	9:30-10:30AM	TTh	Lopez,C						BC 68
	10:30-10:50AM	TTh	Lopez,C						BC 68
MUS 114 - 2.0 UNITS INTERMEDIATE PIANO I									
Transferable to UC, CSU									
Prerequisite: MUS 113 or equivalent with a grade of "C" or higher or "Pass".									
21602	9:30-10:30AM	MW	Lopez,C						BC 68
	10:30-10:50AM	MW	Lopez,C						BC 68
21932	6:30-8:30PM	Th	Chen,J						BC 68
	8:30-9:20PM	Th	Chen,J						BC 68
29090	9:30-10:30AM	TTh	Lopez,C						BC 68
	10:30-10:50AM	TTh	Lopez,C						BC 68
MUS 115 - 2.0 UNITS INTERMEDIATE PIANO II									
Transferable to UC, CSU									
Prerequisite: MUS 114 or equivalent with a grade of "C" or higher or "Pass".									
21598	6:30-8:30PM	Th	Chen,J						BC 68
	8:30-9:20PM	Th	Chen,J						BC 68
21604	9:30-10:30AM	MW	Lopez,C						BC 68
	10:30-10:50AM	MW	Lopez,C						BC 68
MUS 116 - 2.0 UNITS VOICE I									
Transferable to UC, CSU									
20548	12:30-1:30PM	MW	DeMichele,A						BC 51
	1:30-1:50PM	MW	DeMichele,A						BC 51
20549	9:30-10:30AM	TTh	DeMichele,A						BC 51
	10:30-10:50AM	TTh	DeMichele,A						BC 51
MUS 117 - 2.0 UNITS VOICE II									
Transferable to UC, CSU									
Prerequisite: MUS 116 or equivalent with a grade of "C" or higher or "Pass".									
20552	9:30-10:30AM	TTh	DeMichele,A						BC 51
	10:30-10:50AM	TTh	DeMichele,A						BC 51
22193	12:30-1:30PM	MW	DeMichele,A						BC 51
	1:30-1:50PM	MW	DeMichele,A						BC 51

MICROBIOLOGY									
MICR 200 - 5.0 UNITS PRINCIPLES AND APPLICATIONS OF MICROBIOLOGY									
Transferable to UC, CSU (CAN BIOL 14)									
Prerequisite: CHEM 100 or BIOL 120 or ZOOL 120 or equivalent with a grade of "C" or higher or "Pass."									
20541	12:30-1:45PM	MW	Rojas,S	S 202					
20542	9:00-11:50AM	MW	Rojas,S	S 117					
20543	2:00-4:50PM	MW	STAFF	S 117					
21799	1:30-4:20PM	TTh	Rojas,S	S 117					
20938	5:30-6:45PM	TTh	Rojas,S	S 202					
20939	7:00-9:50PM	MW	STAFF	S 117					
20940	7:00-9:50PM	TTh	STAFF	S 117					

Students not in attendance or late for the first class meeting are subject to drop.

Class#	Time	Day	Instructor	Room	Class#	Time	Day	Instructor	Room
MUS 118 - 2.0 UNITS VOICE III					MUS 149 - 1.0 UNIT PRIVATE STUDY/MUSICAL PREPARATION				
Transferable to UC, CSU					Transferable to UC, CSU				
Prerequisite: MUS 117 or equivalent with a grade of "C" or higher or "Pass".					Prerequisite: Audition Required or MUS 148 with a grade of "C" or higher.				
20555	9:30-10:30AM	TTh	DeMichele,A	BC 51	Corequisite: Enrollment in a music ensemble: MUS 200E - MUS 208E, MUS 210E - MUS 213E, MUS 217E, or MUS 219E AND Enrollment in music theory: MUS 180, MUS 181, MUS 280, or MUS 281.				
	10:30-10:50AM	TTh	DeMichele,A	BC 51	20560	11:00-12:00PM	W	Lopez,C	BC 51
22191	12:30-1:30PM	MW	DeMichele,A	BC 51		+ 6.0 HRS ARR		Lopez,C	BC 51
	1:30-1:50PM	MW	DeMichele,A	BC 51	MUS 150 - 1.0 UNIT PRIVATE STUDY/PERFORMANCE PRACTICE				
MUS 119 - 2.0 UNITS VOICE IV					Transferable to UC, CSU				
Prerequisite: MUS 118 or equivalent with a grade of "C" or higher or "Pass".					Prerequisite: Audition Required or MUS 149 with a grade of "C" or higher.				
20554	12:30-1:00PM	MW	DeMichele,A	BC 51	Corequisite: Enrollment in a music ensemble: MUS 200E - MUS 208E, MUS 210E - MUS 213E, MUS 217E, or MUS 219E AND Enrollment in music theory: MUS 180, MUS 181, MUS 280, or MUS 281.				
	1:30-1:50PM	MW	DeMichele,A	BC 51	20561	11:00-12:00PM	W	Lopez,C	BC 51
21606	9:30-10:30AM	TTh	DeMichele,A	BC 51		+ 6.0 HRS ARR		Lopez,C	BC 51
	10:30-10:50AM	TTh	DeMichele,A	BC 51	MUS 151 - 1.0 UNIT PRIVATE STUDY/RECITAL PREPARATION				
MUS 120 - 2.0 UNITS ELEMENTARY GUITAR I					Transferable to UC, CSU				
Prerequisite: MUS 120 or equivalent with a grade of "C" or higher or "Pass".					Prerequisite: Audition Required or MUS 150 with a grade of "C" or higher.				
23580	2:00-4:00PM	M	Torres,M	BC 51	Corequisite: Enrollment in a music ensemble: MUS 200E - MUS 208E, MUS 210E - MUS 213E, MUS 217E, or MUS 219E AND Enrollment in music theory: MUS 180, MUS 181, MUS 280, or MUS 281.				
	4:00-4:50PM	M	Torres,M	BC 51	20562	11:00-12:00PM	W	Lopez,C	BC 51
MUS 121 - 2.0 UNITS ELEMENTARY GUITAR II					+ 6.0 HRS ARR				
Transferable to UC, CSU					Lopez,C				
Prerequisite: MUS 120 or equivalent with a grade of "C" or higher or "Pass".					MUS 153 - 2.0 UNITS THE ART OF TEACHING INTERMEDIATE PIANO				
23582	2:00-4:00PM	M	Torres,M	BC 51	Transferable to CSU				
	4:00-4:50PM	M	Torres,M	BC 51	Prerequisite: MUS 152 or equivalent with a grade of "C" or higher or "Pass".				
MUS 122 - 2.0 UNITS INTERMEDIATE GUITAR I					29202				
Transferable to UC, CSU					12:30-1:50PM				
Prerequisite: MUS 121 or equivalent with a grade of "C" or higher or "Pass".					MW				
23584	2:00-4:00PM	M	Torres,M	BC 51	Lopez,C				
	4:00-4:50PM	M	Torres,M	BC 51	MUS 155 - 3.0 UNITS MUSIC ENTREPRENEURSHIP				
MUS 123 - 2.0 UNITS INTERMEDIATE GUITAR II					Transferable to CSU				
Transferable to UC, CSU					Prerequisite: Completion of MUS 135 or equivalent with a grade of "C" or higher or "Pass."				
Prerequisite: MUS 122 or equivalent with a grade of "C" or higher or "Pass".					Recommendation: Completion of ENGL 52 or ENGL 72 or ESL 152 or equivalent with a grade of "C" or higher or "Pass" or completion of the English Placement Process with a score eligible for ENGL 100.				
23586	2:00-4:00PM	M	Torres,M	BC 51	B30128	6:00-8:50PM	M	Schultz,R	BC61A
	4:00-4:50PM	M	Torres,M	BC 51	MUS 181 - 4.0 UNITS MUSIC THEORY/MUSICIANSHIP II				
MUS 144A - 2.0 UNITS SYNTHESIZER TECHNIQUES					Transferable to UC, CSU				
Transferable to CSU					Prerequisite: MUS 106 or MUS 180 or equivalent with a grade of "Pass" or "C" or higher.				
Prerequisite: MUS 110 or equivalent with a grade of "C" or higher or "Pass".					25240				
Recommendation: Completion of ENGL 52 or ENGL 72 or ESL 152 or equivalent with a grade of "C" or higher or "Pass" or completion of the English Placement Process with a score eligible for ENGL 100.					2:00-4:00PM				
25242	2:00-4:00PM	Th	Maz,A	BC61A		4:00-4:30PM	MW	Lopez,C	BC 53
	4:00-5:50PM	Th	Maz,A	BC61A				Lopez,C	BC 53
MUS 146A - 2.0 UNITS RECORDING TECHNIQUES					MUS 202E - 1.0 UNIT COMMUNITY SYMPHONIC BAND				
Transferable to CSU					Transferable to CSU				
Prerequisite: MUS 110 or equivalent with a grade of "C" or higher or "Pass".					25248				
Recommendation: Completion of ENGL 52 or ENGL 72 or ESL 152 or equivalent with a grade of "C" or higher or "Pass" or completion of the English Placement Process with a score eligible for ENGL 100.					7:00-9:00PM				
25246	2:00-4:00PM	T	Maz,A	BC61B		9:00-10:50PM	T	Betancourt,D	BC 53
	4:00-5:50PM	T	Maz,A	BC61B				Betancourt,D	BC 53
MUS 147 - 1.0 UNIT BASIC APPLIED MUSIC					MUS 203E - 1.0 UNIT COMMUNITY BAND				
Transferable to UC, CSU					Transferable to CSU				
Corequisite: Enrollment in a music performance course related to the student's private study: MUS 200E, or 201E, or 202E, or 203E, or 204E, or 205E, or 206E, or 207E, or 208E, or 209E, or 210E, or 211E, or 213E, or 216E, or 217E, or 218E, or 219E.					25250				
20558	11:00-12:00PM	W	Lopez,C	BC 51		7:00-9:00PM	T	Betancourt,D	BC 53
	+ 6.0 HRS ARR		Lopez,C	BC 51		9:00-10:50PM	T	Betancourt,D	BC 53
MUS 148 - 1.0 UNIT PRIVATE STUDY/TECHNIQUE					MUS 204E - 1.0 UNIT ORCHESTRA				
Transferable to UC, CSU					Transferable to CSU				
Prerequisite: Audition Required or MUS 147 with a grade of "C" or higher.					25252				
Corequisite: Enrollment in a music ensemble: MUS 200E - MUS 208E, MUS 210E - MUS 213E, MUS 217E, or MUS 219E AND Enrollment in music theory: MUS 180, MUS 181, MUS 280, or MUS 281.					6:00-8:00PM				
20559	11:00-12:00PM	W	Lopez,C	BC 51		8:00-9:50PM	M	Hallback,A	BC 53
	+ 6.0 HRS ARR		Lopez,C	BC 51				Hallback,A	BC 53
MUS 206E - 1.0 UNIT STAGE BAND					Transferable to CSU				
Transferable to UC, CSU					25256				
Prerequisite: Audition Required or MUS 147 with a grade of "C" or higher.					7:00-9:00PM				
Corequisite: Enrollment in a music ensemble: MUS 200E - MUS 208E, MUS 210E - MUS 213E, MUS 217E, or MUS 219E AND Enrollment in music theory: MUS 180, MUS 181, MUS 280, or MUS 281.					9:00-10:50PM				
20559	11:00-12:00PM	W	Lopez,C	BC 51			W	Betancourt,D	BC 53
	+ 6.0 HRS ARR		Lopez,C	BC 51			W	Betancourt,D	BC 53
MUS 207E - 1.0 UNIT JAZZ ENSEMBLE					Transferable to CSU				
Transferable to UC, CSU					25258				
Prerequisite: Audition Required or MUS 147 with a grade of "C" or higher.					7:00-9:00PM				
Corequisite: Enrollment in a music ensemble: MUS 200E - MUS 208E, MUS 210E - MUS 213E, MUS 217E, or MUS 219E AND Enrollment in music theory: MUS 180, MUS 181, MUS 280, or MUS 281.					9:00-10:50PM				
20559	11:00-12:00PM	W	Lopez,C	BC 51			W	Betancourt,D	BC 53
	+ 6.0 HRS ARR		Lopez,C	BC 51			W	Betancourt,D	BC 53

Students not in attendance or late for the first class meeting are subject to drop.

Class#	Time	Day	Instructor	Room	Class#	Time	Day	Instructor	Room
MUS 208E - 1.0 UNIT POP/ROCK LATIN ENSEMBLE Transferable to UC, CSU 25260 7:00-11:00PM Th Betancourt,D BC 53 + 4.0 HRS ARR Betancourt,D Class# 25260 meets 03/26/2020-05/21/2020					NRSNG 57LA - 1.0 UNIT BEGINNING NURSING SKILLS LAB Not Transferable Corequisite: NRSNG 210 or NRSNG 212 25630 9:00-9:50AM M Natividad,R HS102 9:00-10:50AM F Veloz-Rendon,L SL121				
MUS 210E - 1.0 UNIT STRING ENSEMBLE Transferable to CSU 25262 12:30-1:30PM TTh Lopez,C BC 68 1:30-1:50PM TTh Lopez,C BC 68					NRSNG 57LB - 1.0 UNIT INTERMEDIATE NURSING SKILLS LAB Not Transferable Corequisite: NRSNG 220 or NRSNG 222 25631 10:00-10:50AM M Natividad,R HS102 11:00-12:50PM F Veloz-Rendon,L SL121				
MUS 216E - 1.0 UNIT PIANO ENSEMBLE Transferable to CSU Prerequisite: MUS 112 or equivalent with a grade of "C" or higher or "Pass." 25264 12:30-1:30PM TTh Lopez,C BC 68 1:30-1:50PM TTh Lopez,C BC 68					NRSNG 57LC - 1.0 UNIT ADVANCED INTERMEDIATE NURSING SKILLS LAB Not Transferable Corequisite: NRSNG 230 or NRSNG 232 25632 9:00-9:50AM Th Gonzalez,K HS102 3:45-5:35PM Th Moreno,J SL121				
MUS 218E - 1.0 UNIT COMMUNITY CHORUS Transferable to CSU 25266 6:30-8:30PM T DeMichele,A BC 51 8:30-10:20PM T DeMichele,A BC 51 25268 12:30-1:30PM TTh DeMichele,A BC 51 1:30-2:20PM TTh DeMichele,A BC 51					NRSNG 57LD - 1.0 UNIT ADVANCED NURSING SKILLS LAB Not Transferable Corequisite: NRSNG 240 or NRSNG 242 25633 10:00-10:50AM Th Gonzalez,K HS102 5:35-7:25PM Th Moreno,J SL121				
MUS 219E - 1.0 UNIT COLLEGIATE CHORALE Transferable to CSU 25270 6:30-8:00PM T DeMichele,A BC 51 8:00-10:20PM T DeMichele,A BC 51 25272 12:30-1:30PM TTh DeMichele,A BC 51 1:30-2:20PM TTh DeMichele,A BC 51					NRSNG 210 - 5.0 UNITS FUNDAMENTALS OF NURSING Transferable to CSU Corequisite: NRSNG 211 21059 12:30-3:40PM MTh Natividad,R SL109 Class# 21059 meets 01/13/2020-03/02/2020 PLEASE ENROLL IN LAB SECTION AS ASSIGNED. THE LECTURE SECTION #21059 WILL BE AUTOMATICALLY ADDED.				
MUS 244A - 2.5 UNITS AUDIO FOR FILM, TV, AND GAMES Transferable to CSU Prerequisite: Completion of MUS 144B or MUS 145 AND MUS 146B or equivalent with a grade of "C" or higher or "Pass." Recommendation: Completion of ENGL 52 or ENGL 72 or ESL 152 or equivalent with a grade of "C" or higher or "Pass" or completion of the English Placement Process with a score eligible for ENGL 100. 30129 12:00-1:50PM M Maz,A BC61A + 2.0 HRS ARR Maz,A BC61A					21060 7:00-12:50PM TW Brown Farr,N LAB A ACH* Class# 21060 meets 01/13/2020-03/02/2020 21061 7:00-12:50PM TW Montez-Ochoa,V LAB B AGMC* Class# 21061 meets 01/13/2020-03/02/2020 21062 7:00-12:50PM TW Gemmill,O LAB C VECH* Class# 21062 meets 01/13/2020-03/02/2020 21063 7:00-12:50PM TW Cooke,M LAB E CPH* Class# 21063 meets 01/13/2020-03/02/2020 22726 7:00-12:50PM TW Alcalá,S LAB D RLA* Class# 22726 meets 01/13/2020-03/02/2020				
MUS 281 - 4.0 UNITS MUSIC THEORY/MUSICIANSHIP IV Transferable to UC, CSU Prerequisite: MUS 108 or MUS 280 or equivalent with a grade of "Pass" or "C" or higher. 26260 8:00-10:00AM MW Da Silva,P BC 53 10:00-10:20AM MW Da Silva,P BC 53					NRSNG 211 - 1.0 UNIT INTRODUCTION TO THEORETICAL FRAMEWORK Transferable to CSU 21119 9:00-10:50AM Th Cooke,M SL109 Class# 21119 meets 01/16/2020-03/12/2020				
NURSING									
Applications for Fall 2020 and Spring 2021 admission into the Nursing Program will be accepted in the Health Occupations Division Office January 6 through March 16, 2020 only. Applications are accepted once a year. Selection criteria have been updated and can be accessed at the Cerritos College Nursing Program website: www.cerritos.edu/registered-nurse . For more information call (562) 860-2451, ext. 2550. Clearance of a criminal background check and drug testing are required prior to clinical field experience.					NRSNG 212 - 5.0 UNITS MEDICAL-SURGICAL NURSING I Transferable to CSU Prerequisite: NRSNG 210 or equivalent with a grade of "C" or higher or "Pass". For Option B students: Possession of an active Licensed Psychiatric Technician license and admission to the Nursing Program Corequisite: NRSNG 211 may be taken prior to admission or concurrent Recommendation: NRSNG 200 or NRSNG 213A or equivalent with a grade of "C" or higher or "Pass". 21120 12:30-2:45PM MTh Gonzalez,K SL109 Class# 21120 meets 03/23/2020-05/21/2020 PLEASE ENROLL IN LAB SECTION AS ASSIGNED. THE LECTURE SECTION #21120 WILL BE AUTOMATICALLY ADDED.				
NRSNG 3 - 2.0 UNITS PREPARING FOR NURSING Not Transferable 22396 9:00-10:50AM Th Robbins II,H SL108					21121 7:00-2:15PM TW Veloz-Rendon,L LAB A PIHD* Class# 21121 meets 03/23/2020-05/21/2020 21122 7:00-2:15PM TW Natividad,R LAB B LRMC* Class# 21122 meets 03/23/2020-05/21/2020 21123 7:00-2:15PM TW Upadhyaya,K LAB C AGMC* Class# 21123 meets 03/23/2020-05/21/2020 21124 7:00-2:15PM TW Ortega,M LAB D PIHD* Class# 21124 meets 03/23/2020-05/21/2020 21125 7:00-2:15PM TW Gonzalez,K LAB E KDMC* Class# 21125 meets 03/23/2020-05/21/2020				
NRSNG 25 - 0.5 UNIT CLINICAL WORKSHOP 1 Not Transferable 25160 4:00-4:30PM W STAFF SL105 4:30-7:45PM W STAFF SL105 Class# 25160 meets 03/25/2020-05/20/2020					NRSNG 213A - 0.5 UNIT MAJOR DRUGS AND NURSING MANAGEMENT I Transferable to CSU 25233 9:00-10:15AM Th Brooks,K SL109 Class# 25233 meets 04/16/2020-05/21/2020				
NRSNG 26 - 0.5 UNIT CLINICAL WORKSHOP 2 Not Transferable 21058 4:00-4:30PM W STAFF SL105 4:30-7:45PM W STAFF SL105 Class# 21058 meets 03/25/2020-05/20/2020									
NRSNG 48T - 0.5 UNIT ELECTIVE NURSING - TUTORIAL Not Transferable 21898 4:00-7:50PM W Riedel,P SL121 Class# 21898 meets 01/15/2020-03/11/2020									

Students not in attendance or late for the first class meeting are subject to drop.

Class#	Time	Day	Instructor	Room	Class#	Time	Day	Instructor	Room
NRSNG 213B - 1.0 UNIT MAJOR DRUGS AND NURSING MANAGEMENT II					NRSNG 232 - 5.0 UNITS MEDICAL-SURGICAL NURSING 4				
Transferable to CSU					Transferable to CSU				
Prerequisite: NRSNG 213A or equivalent with a grade of "C" or higher or "Pass".					Prerequisite: NRSNG 230 or equivalent with a grade of "C" or higher or "Pass".				
For Option C, D, and E students: Admission to the Nursing Program.					For Option C, D, and E students: Admission to the Nursing Program.				
21511	4:00-5:50PM	Th	Brooks,K	SL108	21129	12:30-2:45PM	WTh	Moreno,J	HS305
Class# 21511 meets 01/16/2020-03/12/2020					Class# 21129 meets 03/23/2020-05/21/2020				
NRSNG 215 - 1.0 UNIT ADVANCED PLACEMENT BRIDGE					PLEASE ENROLL IN LAB SECTION AS ASSIGNED. THE LECTURE SECTION #21129 WILL BE AUTOMATICALLY ADDED.				
Transferable to CSU					7:00- 6:50PM M Robbins II,H LAB A KDMC*				
Recommendation: Completion of READ 54, ENGL 52, and MATH 60 or equivalent with grades of Pass or "C" or higher or successful completion of the college placement process.					3.0 HRS ARR Robbins II,H LAB A KDMC*				
21653	4:00-5:50PM	Th	Riedel,P	SL108	21130	7:00- 6:50PM M Robbins II,H LAB A KDMC*	Class# 21130 meets 03/23/2020-05/21/2020		
Class# 21653 meets 03/26/2020-05/21/2020					21131 6:00-1:15PM MT STAFF LAB B ARMC*				
					Class# 21131 meets 03/23/2020-05/21/2020				
NRSNG 220 - 5.5 UNITS MEDICAL-SURGICAL NURSING 3					21132 7:00-6:50PM M Brown Farr,N LAB C RLA *				
Transferable to CSU					4.33 HRS ARR Brown Farr,N LAB C RLA *				
Prerequisite: NRSNG 211, NRSNG 212 and NRSNG 213A or equivalent with a grade of "C" or higher or "Pass".For Option B and E students.					Class# 21132 meets 03/23/2020-05/21/2020				
21065	12:30-3:40PM	MTh	Orozco,R	SL108	21163	7:00-6:50PM T Caminiti,C LAB D LAH *	3.0 HRS ARR Caminiti,C LAB D LAH *		
Class# 21065 meets 01/13/2020-03/02/2020					Class# 21163 meets 03/23/2020-05/21/2020				
PLEASE ENROLL IN LAB SECTION AS ASSIGNED. THE LECTURE SECTION #21065 WILL BE AUTOMATICALLY ADDED.					21164 2:00-9:15PM MT Moreno,J LAB E ARMC*				
21066	3:00-10:15PM	TW	STAFF	LAB A	Class# 21164 meets 03/23/2020-05/21/2020				
Class# 21066 meets 01/13/2020-03/02/2020					NRSNG 240 - 5.0 UNITS MEDICAL-SURGICAL NURSING 5				
21067	7:00-2:15PM	TW	Veloz-Rendon,L	LAB B	Transferable to CSU				
Class# 21067 meets 01/13/2020-03/02/2020					Prerequisite: NRSNG 232 or equivalent with a grade of "C" or higher or "Pass".				
21068	7:00-2:15PM	TW	Orozco,R	LAB C	For Option E and F students: Admission to the Nursing Program.				
Class# 21068 meets 01/13/2020-03/02/2020					21076 12:30-2:45PM WTh Riedel,P HS102				
21069	7:00-2:15PM	TW	Moreno,J	LAB D	Class# 21164 meets 03/23/2020-05/21/2020				
Class# 21069 meets 01/13/2020-03/02/2020					PLEASE ENROLL IN LAB SECTION AS ASSIGNED. THE LECTURE SECTION #21076 WILL BE AUTOMATICALLY ADDED.				
21100	3:00-10:15PM	TW	Pison,T	LAB E	21077 7:00-6:50PM M Smith,S LAB A PIHW*				
Class# 21100 meets 01/13/2020-03/02/2020					5.67 HRS ARR Smith,S LAB A PIHW*				
NRSNG 222 - 5.5 UNITS MATERNAL/CHILD NURSING					21078 6:00- 5:50PM T Beckerleg,N LAB B ARMC*				
Transferable to CSU					5.67HRS ARR Beckerleg,N LAB B ARMC*				
Prerequisite: NRSNG 220 or equivalent with a grade of "C" or higher or "Pass".					21079 7:00-3:10PM MT Robbins II,H LAB C PIHD*				
21126	12:30-3:20PM	MTh	Orozco,R	SL108	Class# 21079 meets 01/13/2020-03/02/2020				
Class# 21126 meets 01/13/2020-03/02/2020					21102 3:00-11:10PM MT Riedel,P LAB E LAH *				
PLEASE ENROLL IN LAB SECTION AS ASSIGNED. THE LECTURE SECTION #21126 WILL BE AUTOMATICALLY ADDED.					Class# 21102 meets 01/13/2020-03/02/2020				
21127	7:00-2:15PM	TW	Castro,V	LAB A	28723 2:00-9:50PM MT Mejia,E LAB D LRMC*				
Class# 21127 meets 03/23/2020-05/21/2020					Class# 28723 meets 01/13/2020-03/02/2020				
26064	3:00-10:15PM	TW	Orozco,R	LAB B	NRSNG 242 - 3.0 UNITS PROFESSIONAL ROLE TRANSITION				
Class# 26064 meets 03/23/2020-05/21/2020					Transferable to CSU				
23291	7:00-6:50PM	F	Castro,V	LAB C	Prerequisite: NRSNG 240 or equivalent with a grade of "C" or higher or "Pass".				
Class# 23291 meets 03/23/2020-05/21/2020					NRSNG 242 students: Preceptee hours are variable based upon the work schedule of the hospital clinical preceptor. Students may be required to complete hours during regular business hours, evenings, and/or weekends.				
21162	6:00-1:15PM	SatSun	Cochran,M	LAB D	21512 12:30-1:45PM Th Cooke,M HS102				
Class# 21162 meets 03/23/2020-05/21/2020					Class# 21512 meets 01/13/2020-03/02/2020				
21161	3:00-10:15PM	TW	Knapp,J	LAB E	PLEASE ENROLL IN LAB SECTION AS ASSIGNED. THE LECTURE SECTION #21512 WILL BE AUTOMATICALLY ADDED.				
Class# 21161 meets 03/23/2020-05/21/2020					21513 23.0 HRS ARR Cooke,M LAB A KDMC*				
NRSNG 230 - 5.0 UNITS PSYCHOSOCIAL AND COMMUNITY NURSING					Class# 21513 meets 03/23/2020-05/01/2020				
Transferable to CSU					21514 23.0 HRS ARR Natividad,R LAB B PIHW*				
Prerequisite: NRSNG 222 or equivalent with a grade of "C" or higher or "Pass".					Class# 21514 meets 03/23/2020-05/01/2020				
For Option C, D, E and F students: Admission to the Nursing Program.					21515 23.0 HRS ARR Alcala,S LAB C RLA *				
21070	12:30-3:20PM	WTh	Gonzalez,K	HS305	Class# 21515 meets 03/23/2020-05/01/2020				
Class# 21070 meets 03/23/2020-05/21/2020					21516 23.0 HRS ARR Riedel,P LAB D LRMC*				
PLEASE ENROLL IN LAB SECTION AS ASSIGNED. THE LECTURE SECTION #21070 WILL BE AUTOMATICALLY ADDED.					Class# 21516 meets 03/23/2020-05/01/2020				
21071	7:00-6:50PM	T	Clement,J	LAB A	NRSNG 251 - 1.0 UNIT BASIC ADULT PHYSICAL ASSESSMENT				
Class# 21071 meets 01/13/2020-03/12/2020					Transferable to CSU				
21072	7:00-6:50PM	SAT	Yannitelli,K	LAB B	Prerequisite: NRSNG 240 or equivalent with a grade of "C" or higher or "Pass".				
Class# 21072 meets 01/13/2020-03/12/2020					NRSNG 251 students: Preceptee hours are variable based upon the work schedule of the hospital clinical preceptor. Students may be required to complete hours during regular business hours, evenings, and/or weekends.				
21073	7:00-1:30PM	MT	Caminiti,C	LAB C	21899 4:00-5:05PM M Caminiti,C SL105				
Class# 21073 meets 01/13/2020-03/12/2020					5:05-8:40PM M Caminiti,C SL105				
21074	3:30-10:00PM	MT	Intalapitagsa,D	LAB D	Class# 21899 meets 01/13/2020-03/09/2020				
Class# 21074 meets 01/13/2020-03/12/2020									
29557	7:00- 6:50PM	M	Gonzalez,K	LAB E					
Class# 29557 meets 01/13/2020-03/12/2020									

Students not in attendance or late for the first class meeting are subject to drop.

Class#	Time	Day	Instructor	Room	Class#	Time	Day	Instructor	Room
--------	------	-----	------------	------	--------	------	-----	------------	------

PHARMACY TECHNICIAN

Students who wish to complete the program at an accelerated pace must make an appointment with the program director by calling (562) 860-2451, ext. 2562. Clearance of a criminal background check and/or drugs of abuse testing may be required prior to clinical field experience.

PHAR 50 - 1.5 UNITS PHARMACEUTICS

Not Transferable
Prerequisite: HO 56 or equivalent with a grade of "C" or higher or "Pass".

21167	9:00-11:50AM	W	Makarem,N	SL108
-------	--------------	---	-----------	-------

Class# 21167 meets 03/25/2020-05/20/2020

PHAR 55 - 1.5 UNITS PHARMACY INTRODUCTION

Not Transferable
Corequisite: PHAR 56

23293	8:00-10:50AM	T	Makarem,N	SL101
-------	--------------	---	-----------	-------

Class# 23293 meets 01/14/2020-03/10/2020

PHAR 56 - 0.5 UNIT PHARMACY SKILLS LAB INTRODUCTION

Not Transferable
Corequisite: PHAR 55

23294	11:00-12:00PM	T	Shields,J	SL101
	12:00-1:50PM	T	Shields,J	SL101

Class# 23294 meets 01/14/2020-03/10/2020

PHAR 57 - 1.5 UNITS PHARMACY OPERATIONS I

Not Transferable
Prerequisite: PHAR 55 or equivalent with a grade of "C" or higher or "Pass" or concurrent enrollment.

23298	8:00-11:10AM	F	Casas,R	SL108
-------	--------------	---	---------	-------

Class# 23298 meets 01/17/2020-03/13/2020

PHAR 63 - 2.0 UNITS PHARMACY OPERATIONS II

Not Transferable
Prerequisite: PHAR 55, PHAR 56, and PHAR 57 or equivalent with grades of Pass or "C" or higher.

20641	8:00-12:00PM	T	Shields,J	SL101
	12:00-1:50PM	T	Shields,J	SL101

Class# 20641 meets 03/24/2020-05/19/2020

PHAR 64 - 2.0 UNITS PHARMACY OPERATIONS III

Not Transferable
Prerequisite: PHAR 50, PHAR 55, PHAR 56, PHAR 57, and PHAR 63 or equivalents with grades of Pass or "C" or higher. PHAR 63 may be taken concurrently with PHAR 64; however PHAR 64 cannot be taken prior to PHAR 63.

20974	8:00-10:00AM	F	Shields,J	SL101
	10:00-10:50AM	F	Shields,J	SL101

PHAR 65 - 2.0 UNITS PHARMACY OPERATIONS IV - NON-STERILE COMPOUNDING

Not Transferable
Prerequisite: PHAR 50 and PHAR 63 or equivalent with grades of Pass or "C" or higher.

22477	9:30-11:30AM	W	Casas,R	SL101
	11:30-12:20PM	W	Casas,R	SL101

PHAR 81 - 3.0 UNITS OVER-THE-COUNTER PRODUCTS

Not Transferable
Recommendation: MA 161 or A&P 120 or equivalent with a grade of "C" or higher or "Pass".

20642	9:00-11:50AM	M	Makarem,N	SL101
-------	--------------	---	-----------	-------

PHAR 83 - 3.0 UNITS PHARMACY TECHNICIAN PHARMACOLOGY I

Not Transferable
Prerequisite: MA 161 or A&P 120 or equivalent with a grade of "C" or higher or "Pass".

20975	8:00-10:50AM	T	Casas,R	SL108
-------	--------------	---	---------	-------

PHAR 85 - 3.0 UNITS PHARMACY TECHNICIAN PHARMACOLOGY II

Not Transferable
Prerequisite: MA 161 or A&P 120 or equivalent with a grade of "C" or higher or "Pass".

20643	8:00-10:50AM	Th	Casas,R	SL101
-------	--------------	----	---------	-------

PHAR 90 - 3.0 UNITS CLINICAL EXPERIENCE I

Not Transferable
Prerequisite: PHAR 50, PHAR 63, PHAR 65, and PHAR 81 or equivalents with grades of "C" or higher or "Pass".

20644	8:00-8:50AM	M	Makarem,N	SL101
-------	-------------	---	-----------	-------

+ 6.7 HRS ARR
Makarem,N

PHAR 95 - 5.0 UNITS CLINICAL EXPERIENCE II

Not Transferable
Prerequisite: PHAR 64, PHAR 83, and PHAR 85 or equivalent with grades of Pass or "C" or higher.

20645	8:00-8:50AM	W	Makarem,N	SL101
-------	-------------	---	-----------	-------

+ 11.1 HRS ARR
Makarem,N

PHILOSOPHY

PHIL 100 - 3.0 UNITS INTRODUCTION TO PHILOSOPHY

Transferable to UC, CSU (CAN PHIL 2)
Prerequisite: Completion of ENGL 52, or ENGL 72 or ESL 152 or equivalent with a grade of "C" or higher, or "Pass," or completion of the English Placement Process with eligibility for ENGL 100.

23345	7:00-9:50PM	M	Spooner,G	SS137
22616	9:30-10:45AM	MW	Van De Mortel,J	SS136
23346	8:00-9:15AM	MW	Pereira,J	SS136
20647	11:00-12:15PM	MW	Stolze,T	SS137
22620	7:00-9:50PM	T	Deering,M	SS136
20976	12:30-1:45PM	MW	Mittendorf,R	SS137
20977	7:00-9:50PM	Th	Deering,M	SS136
26813	12:30-1:45PM	TTh	Stolze,T	SS137
29164	8:00-9:15AM	TTh	Sliff,R	SS136

PHIL 102 - 3.0 UNITS INTRODUCTION TO ETHICS

Transferable to UC, CSU (CAN PHIL 4)
Prerequisite: Completion of ENGL 52, or ENGL 72 or ESL 152 or equivalent with a grade of "C" or higher, or "Pass," or completion of the English Placement Process with eligibility for ENGL 100.

21690	12:30-1:45PM	MW	Van De Mortel,J	SS136
21691	9:30-10:45AM	TTh	Sliff,R	SS137
21949	7:00-9:50PM	W	Cho,Y	SS137
26400	12:30-1:45PM	TTh	Van De Mortel,J	SS136
28955	3.0 HRS ARR	(OL)	Sutherland,C	ONLINE

Note: All class information will be available in Canvas

28956	3.0 HRS ARR	(OL)	Sutherland,C	ONLINE
-------	-------------	------	--------------	--------

Note: All class information will be available in Canvas

PHIL 103 - 3.0 UNITS PHILOSOPHICAL REASONING: CRITICAL THINKING IN PHILOSOPHY

Transferable to UC, CSU
Prerequisite: ENGL 100 or equivalent with a grade of "C" or higher or "Pass" or satisfactory completion of the Advanced Placement English Examination of the College Entrance Examination Board.

20651	9:30-10:45AM	TTh	Swearingin,R	BE110
20652	12:30-1:45PM	TTh	Mittendorf,R	BE105
21950	7:00-9:50PM	T	Spooner,G	SS137
26384	11:00-12:15PM	MW	Chatman,T	BE105
27378	2:00-3:15PM	MW	Mittendorf,R	BE105
27386	9:30-10:45AM	MW	Chatman,T	BE105
28170	9:30-10:45AM	TTh	Mittendorf,R	BE105

PHIL 104 - 3.0 UNITS PHILOSOPHY OF CULTURAL DIVERSITY: CHALLENGE AND CHANGE

Transferable to UC, CSU
Prerequisite: Completion of ENGL 52, ENGL 72, ESL 152 or equivalent with a grade of "C" or higher or "Pass", or completion of the English Placement Process with eligibility for ENGL 100.

26353	3.0 HRS ARR	(OL)	Mayock,M	ONLINE
-------	-------------	------	----------	--------

Note: All class information will be available in Canvas

28053	2:00-3:15PM	TTh	Mittendorf,R	SS136
-------	-------------	-----	--------------	-------

PHIL 106 - 3.0 UNITS INTRODUCTION TO LOGIC

Transferable to UC, CSU (CAN PHIL 6)
Prerequisite: ENGL 100 or equivalent with a grade of "C" or higher or "Pass."

20649	7:00-9:50PM	W	Deering,M	SS136
20979	11:00-12:15PM	MW	Van De Mortel,J	SS136
28663	2:00-3:15PM	TTh	Swearingin,R	SS138

PHIL 109 - 3.0 UNITS PHILOSOPHY OF THE BODY, FEMINISM, AND GENDER

Transferable to UC, CSU
Prerequisite: Completion of ENGL 52, or ENGL 72, or ESL 152 or equivalent with a grade of "C" or higher or "Pass", or completion of the English Placement Process with eligibility for ENGL 100.

27311	2:00-3:15PM	TTh	Mayock,M	LC 22
-------	-------------	-----	----------	-------

Students not in attendance or late for the first class meeting are subject to drop.

Class#	Time	Day	Instructor	Room	Class#	Time	Day	Instructor	Room
PHIL 140 - 3.0 UNITS HISTORY OF MODERN PHILOSOPHY Transferable to UC, CSU Prerequisite: Completion of ENGL 52, or ENGL 72, or ESL 152, or equivalent with a grade of "C" or higher or "Pass" or completion of the placement process with eligibility for ENGL 100.									
28081	12:30-1:45PM	MW	Stolze,T	BE106					
PHIL 200 - 3.0 UNITS WORLD RELIGIONS Transferable to UC, CSU Recommendation: Satisfactory completion of the English Placement Process or ENGL 52 or ENGL 155 or equivalent with a grade of "C" or higher or "Pass" is strongly recommended.									
22301	9:30-10:45AM	TTh	Van De Mortel,J	SS136					
PHIL 201 - 3.0 UNITS CONTEMPORARY PHILOSOPHY Transferable to UC, CSU Prerequisite: Completion of ENGL 52, or ENGL 72 or ESL 152 or equivalent with a grade of "C" or higher, or "Pass," or completion of the English Placement Process with eligibility for ENGL 100. Recommendation: Satisfactory completion of READ 42 or READ 48 or equivalent with a grade of "C" or higher or "Pass" This course is a survey of the major philosophical movements that characterize the twentieth and twenty-first centuries, including the rise of Continental, Anglo-American, Marxist, Feminist, Asian, African, and Latin American philosophies.									
21962	2:00-3:15PM	TTh	Stolze,T	BE105					
PHOTOGRAPHY									
PHOT 100 - 3.0 UNITS INTRODUCTORY PHOTOGRAPHY Transferable to UC, CSU (CAN ART 18)									
20653	8:00-9:00AM	MW	Fernandez,C	FA222					
	9:00-10:50AM	MW	Fernandez,C	FA221					
20655	9:30-10:30AM	TTh	Flanders,M	FA221					
	10:30-12:20PM	TTh	Flanders,M	FA222					
23320	12:30-1:30PM	TTh	Heckerman,E	FA222					
	1:30-3:20PM	TTh	Heckerman,E	FA221					
20980	9:00-11:00AM	F	Emmett,K	FA222					
	11:00-2:50PM	F	Emmett,K	FA221					
20981	11:00-12:00PM	MW	Fernandez,C	FA222					
	12:00-1:50PM	MW	Fernandez,C	FA221					
28132	6:30-7:30PM	TTh	Schwenkmeyer,K	FA221					
	7:30-9:20PM	TTh	Schwenkmeyer,K	FA222					
21831	6:30-7:30PM	MW	STAFF	FA222					
	7:30-9:20PM	MW	STAFF	FA222					
25689	9:00-11:00AM	Sat	Chartier,R	FA222					
	11:00-4:00PM	Sat	Chartier,R	FA221					
Class# 25689 meets 01/18/2020-05/16/2020									
PHOT 102 - 3.0 UNITS INTERMEDIATE PHOTOGRAPHY Transferable to CSU Prerequisite: PHOT 100 or equivalent with a grade of Credit or "C" or higher.									
27902	3:30-4:30PM	TTh	Heckerman,E	FA221					
	4:30-6:20PM	TTh	Heckerman,E	FA222					
PHOT 110 - 3.0 UNITS INTRODUCTION TO DIGITAL PHOTOGRAPHY Transferable to CSU									
20656	8:00-9:00AM	TTh	Fernandez,C	FA234					
	9:00-10:50AM	TTh	Fernandez,C	FA234					
23322	6:30-7:30PM	TTh	Sanchez,A	FA239					
	7:30-9:20PM	TTh	Sanchez,A	FA234					
PHOT 112 - 3.0 UNITS INTERMEDIATE DIGITAL PHOTOGRAPHY Transferable to CSU Prerequisite: PHOT 110 or ART 192 or equivalent with a grade of Pass or "C" or higher.									
28021	8:00-9:00AM	TTh	Fernandez,C	FA234					
	9:00-10:50AM	TTh	Fernandez,C	FA234					
PHOT 150 - 3.0 UNITS PHOTOGRAPHY AND SOCIETY Transferable to UC, CSU									
27210	4:30-5:50PM	TTh	Schwenkmeyer,K	FA133					
PHOT 160 - 3.0 UNITS HISTORY OF PHOTOGRAPHY Transferable to UC, CSU									
20657	6:00-8:50PM	M	Goldsmith,M	FA133					
					PHOT 230 - 3.0 UNITS PORTRAIT PHOTOGRAPHY Transferable to CSU Prerequisite: PHOT 100 or equivalent with a grade of Credit or "C" or higher.				
30282	3:00-4:00PM	MW	Heckerman,E	FA221					
	4:00-5:50PM	MW	Heckerman,E	FA221					
PHYSICAL EDUCATION									
PEX 100 - 1.0 UNIT FITNESS FOR STUDENT'S WITH DISABILITIES Transferable to UC, CSU Physical Education activity classes require appropriate attire; equipment is furnished unless noted. Students using locker room facilities must purchase a combination lock for security purposes. The lock number is recorded. Towels are furnished.					DESIGNED FOR STUDENTS WITH DISABILITIES				
PEX 100- PEX 108 Prior to enrolling in PEX 100-105 class(es), student please contact Disabled Student Programs and Services (DSPS) in the LA/DSPS building to complete a "Request for Certification of Physical Condition/Limitations". For additional information contact DSPS at (562) 860-2451 ext. 2333.									
27948	1:00-1:15PM	MW	O'Connor,J	K 105					
	1:15-1:50PM	MW	O'Connor,J	K 105					
30158	1:30-2:00PM	TTh	STAFF	K 105					
	2:00-3:20PM	TTh	STAFF	K 105					
Class# 30158 meets 03/24/2020-05/21/2020									
PEX 100A - 1.0 UNIT ADAPTED INDEPENDENT EXERCISE Transferable to UC, CSU									
28813	1:00-1:15PM	MW	O'Connor,J	K 105					
	1:15-1:50PM	MW	O'Connor,J	K 105					
28815	12:30-12:45PM	TTh	O'Connor,J	K 105					
	12:45-1:20PM	TTh	O'Connor,J	K 105					
29742	9:30-9:45AM	TTh	STAFF	CTS					
	9:45-10:20AM	TTh	STAFF	CTS					
28817	1:30-2:00PM	TTh	O'Connor,J	K 105					
	2:00-3:20PM	TTh	O'Connor,J	K 105					
Class# 28817 meets 01/14/2020-03/12/2020									
PEX 101 - 1.0 UNIT WHEELCHAIR ACTIVITIES Transferable to UC, CSU Recommendation: Completed adapted physical education physician health clearance for participation, adapted physical education health history questionnaire, intake interview assessment procedures.									
29744	10:00-10:15AM	TTh	O'Connor,J	GYM					
	10:15-10:50AM	TTh	O'Connor,J	GYM					
PEX 102 - 1.0 UNIT ADAPTED CARDIOVASCULAR EXERCISES Transferable to UC, CSU Recommendation: Completed adapted physical education physician health clearance for participation, adapted physical education health history questionnaire, intake interview assessment procedures.									
30160	9:30-9:45AM	TTh	STAFF	CTS					
	9:45-10:20AM	TTh	STAFF	CTS					
25360	12:30-12:45PM	TTh	O'Connor,J	K 105					
	12:45-1:20PM	TTh	O'Connor,J	K 105					
29746	1:30-2:00PM	TTh	O'Connor,J	K 105					
	1:30-2:00PM	TTh	O'Connor,J	K 105					
Class# 29746 meets 01/14/2020-03/12/2020									
PEX 103 - 1.0 UNIT ADAPTED STRENGTH TRAINING Transferable to CSU Recommendation: Completed adapted physical education physician health clearance for participation, adapted physical education health history questionnaire, intake interview assessment procedures.									
25366	12:00-12:15PM	MW	O'Connor,J	K 105					
	12:15-12:50PM	MW	O'Connor,J	K 105					
30162	1:30-2:00PM	TTh	STAFF	K 105					
	2:00-3:20PM	TTh	STAFF	K 105					
Class# 30162 meets 03/24/2020-05/21/2020									

Students not in attendance or late for the first class meeting are subject to drop.

Class#	Time	Day	Instructor	Room	Class#	Time	Day	Instructor	Room
PEX 103A - 1.0 UNIT ADAPTED CIRCUIT WEIGHT TRAINING					PEX 120 - 1.5 UNITS CARDIO KICKBOXING				
Transferable to UC, CSU					Transferable to UC, CSU				
28848	12:00-12:15PM	MW	O'Connor,J	K 105	30094	11:00-11:30AM	MW	STAFF	PE116
	12:15-12:50PM	MW	O'Connor,J	K 105		11:30-12:15PM	MW	STAFF	PE116
30164	9:30-9:45AM	TTh	STAFF	CTS	PEX 121 - 1.0 UNIT HIGH-INTENSITY INTERVAL TRAINING				
	9:45-10:20AM	TTh	STAFF	CTS	Transferable to UC, CSU				
PEX 104 - 1.0 UNIT ADAPTED STRETCHING AND RELAXATION					Recommendation: Students should be able to participate safely in a high-intensity exercise program.				
Transferable to UC, CSU					30096	1:00-1:15PM	MW	STAFF	PE116
Recommendation: Completed adapted physical education physician health clearance for participation, adapted physical education health history questionnaire, intake interview assessment procedures.						1:15-1:50PM	MW	STAFF	PE116
25374	1:00-1:15PM	MW	O'Connor,J	K 105	30172	10:00-10:15AM	MW	STAFF	HS103
	1:15-1:50PM	MW	O'Connor,J	K 105		10:15-10:50AM	MW	STAFF	BC 47
30166	1:30-2:00PM	TTh	STAFF	K 105	PEX 122 - 1.5 UNITS CROSS FIT TRAINING AND FUNCTIONAL EXERCISES				
	2:00-3:20PM	TTh	STAFF	K 105	Transferable to UC, CSU				
Class# 30166 meets 03/24/2020-05/21/2020					30098	4:00-4:30PM	TTh	STAFF	PE116
PEX 105 - 1.0 UNIT ADAPTED SWIMMING						4:30-5:15PM	TTh	STAFF	PE116
Transferable to UC, CSU					PEX 124 - 1.0 UNIT PERSONAL FITNESS PROGRAM				
Recommendation: Completed adapted physical education physician health clearance for participation, adapted physical education health history questionnaire, intake interview assessment procedures.					Transferable to UC, CSU				
25378	1:30-2:00PM	TTh	O'Connor,J	POOL	25390	9:30-9:45AM	MW	Kozlowski,T	K 129
	2:00-3:20PM	TTh	O'Connor,J	POOL		9:45-10:20AM	MW	Kozlowski,T	K 129
Class# 25378 meets 03/24/2020-05/21/2020					25392	11:00-11:15AM	MW	Edwards,C	K 129
PEX 106 - 1.0 UNIT ADAPTED AQUATIC EXERCISE						11:15-11:50AM	MW	Edwards,C	K 129
Transferable to UC, CSU					25394	2:00-2:15PM	MW	STAFF	K 129
28821	1:30-2:00PM	TTh	O'Connor,J	POOL		2:15-2:50PM	MW	STAFF	K 129
	1:30-3:20PM	TTh	O'Connor,J	POOL	25396	9:30-9:45AM	TTh	Kozlowski,T	K 129
Class# 28821 meets 03/24/2020-05/21/2020						9:45-10:20AM	TTh	Kozlowski,T	K 129
PEX 107 - 1.0 UNIT ADAPTED TEAM SPORTS					27226	8:30-8:45AM	TTh	O'Connor,J	K 129
Transferable to CSU						8:45-9:20AM	TTh	O'Connor,J	K 129
Recommendation: Completed adapted physical education physician health clearance for participation, adapted physical education health history questionnaire, intake interview assessment procedures.					29750	6:00-6:15PM	TTh	STAFF	K 129
27862	10:00-10:15AM	TTh	O'Connor,J	GYM		6:15-6:50PM	TTh	STAFF	K 129
	10:15-10:50AM	TTh	O'Connor,J	GYM	25402	4:00-4:30PM	MW	Velazquez-Ortega,M	K 129
PEX 107A - 1.0 UNIT ADAPTED SOCCER						4:30-5:50PM	MW	Velazquez-Ortega,M	K 129
Transferable to UC, CSU					Class# 25402 meets 03/23/2020-05/20/2020				
30168	12:00-12:15PM	TTh	STAFF	SOCR	29223	4:00-4:30PM	TTh	Velazquez-Ortega,M	K 129
	12:15-12:50PM	TTh	STAFF	SOCR		4:30-5:50PM	TTh	Velazquez-Ortega,M	K 129
PEX 108 - 1.0 UNIT ADAPTED INDIVIDUAL SPORTS					Class# 29223 meets 03/24/2020-05/21/2020				
Transferable to CSU					PEX 130 - 1.0 UNIT WEIGHT MANAGEMENT				
Recommendation: Completed adapted physical education physician health clearance for participation, adapted physical education health history questionnaire, intake interview assessment procedures.					Transferable to UC, CSU				
27864	10:00-10:15AM	MW	O'Connor,J	CTS	25406	8:30-8:45AM	TTh	O'Connor,J	K 129
	10:15-10:50AM	MW	O'Connor,J	CTS		8:45-9:20AM	TTh	O'Connor,J	K 129
28850	11:00-11:15AM	MW	STAFF	CTS	PEX 132 - 1.0 UNIT INDOOR CYCLING				
	11:15-11:50AM	MW	STAFF	CTS	Transferable to UC, CSU				
PEX 109 - 1.0 UNIT ADAPTED GROUP FITNESS					30100	10:00-10:15AM	MW	STAFF	PE116
Transferable to UC, CSU						10:15-10:50AM	MW	STAFF	PE116
30170	11:00-11:15AM	TTh	STAFF	GYM	30102	11:00-11:15AM	TTh	STAFF	PE116
	11:15-11:50AM	TTh	STAFF	GYM		11:15-11:50AM	TTh	STAFF	PE116
PEX 113 - 1.0 UNIT ZUMBA					PEX 134 - 1.0 UNIT BODY SCULPTING				
Transferable to UC, CSU					Transferable to UC, CSU				
30092	9:30-9:45AM	TTh	STAFF	PE116	25408	8:30-8:45AM	TTh	STAFF	GYM
	9:45-10:20AM	TTh	STAFF	PE116		8:45-9:20AM	TTh	STAFF	GYM
PEX 116 - 1.0 UNIT WATER AEROBICS					25410	8:00-8:30AM	F	STAFF	GYM
Transferable to UC, CSU						8:30-9:50AM	F	STAFF	GYM
26318	1:30-2:00PM	TTh	STAFF	POOL	PEX 135 - 1.5 UNITS ROPES, BANDS, AND SUSPENSION TRAINING				
	2:00-3:20PM	TTh	STAFF	POOL	Transferable to UC, CSU				
Class# 26318 meets 03/24/2020-05/21/2020					30104	12:30-1:00PM	TTh	STAFF	PE116
PEX 119 - 1.0 UNIT BASIC TRAINING AND PHYSICAL CONDITIONING						1:00-1:45PM	TTh	STAFF	PE116
Transferable to UC, CSU					PEX 136 - 1.0 UNIT STRETCHING AND RELAXATION				
28823	2:00-2:15PM	MW	Artiaga,B	K 108	Transferable to UC, CSU				
	2:15-2:50PM	MW	Artiaga,B	K 108	25414	11:00-11:15AM	TTh	STAFF	GYM
29748	2:00-2:15PM	TTh	Caines,T	K 108		11:15-11:50AM	TTh	STAFF	GYM
	2:15-2:50PM	TTh	Caines,T	K 108	26137	1:00-1:15PM	MW	Jensen,D	GYM
						1:15-1:50PM	MW	Jensen,D	GYM
					28247	2:30-3:00PM	TTh	STAFF	DS102
						3:00-4:20PM	TTh	STAFF	DS102
					Class# 28247 meets 03/24/2020-05/21/2020				
PEX 138 - 1.0 UNIT WALKING FOR FITNESS					PEX 138 - 1.0 UNIT WALKING FOR FITNESS				
Transferable to UC, CSU					Transferable to UC, CSU				
28852	8:00-8:15AM	MW	Jensen,D	STADT		8:15-8:50AM	MW	Jensen,D	STADT

Students not in attendance or late for the first class meeting are subject to drop.

Class#	Time	Day	Instructor	Room	Class#	Time	Day	Instructor	Room
PEX 172 - 1.0 UNIT FLAG FOOTBALL					PEX 240 - 2.0 UNITS JOGGING FOR FITNESS, INTERMEDIATE				
Transferable to UC, CSU					Transferable to UC, CSU				
26880	4:00-4:30PM	MW	STAFF	FH	25548	7:30-8:00AM	MW	Jensen,D	STADT
	4:30-5:50PM	MW	STAFF	FH		8:00-9:20AM	MW	Jensen,D	STADT
Class# 26880 meets 03/23/2020-05/20/2020					PEX 245 - 2.0 UNITS CIRCUIT WEIGHT TRAINING, INTERMEDIATE/ADVANCED				
PEX 176 - 1.0 UNIT GOLF, BEGINNING					Transferable to UC, CSU				
Transferable to UC, CSU					25552	8:00-8:30AM	MW	STAFF	K 108
25507	9:00-9:30AM	F	Caines,T	K 108		8:30-9:50AM	MW	STAFF	K 108
	9:30-10:50AM	F	Caines,T	K 108	25554	9:00-9:30AM	MW	Richardson,C	K 108
PEX 178 - 1.0 UNIT SOCCER, BEGINNING						9:30-10:50AM	MW	Richardson,C	K 108
Transferable to UC, CSU					25558	11:00-11:30AM	MW	May,R	K 108
25509	11:00-11:15AM	MW	Artiaga,B	SOCR		11:30-12:50PM	MW	May,R	K 108
	11:15-11:50AM	MW	Artiaga,B	SOCR	25562	1:00-1:50PM	M	Caines,T	K 108
25512	11:00-11:30AM	F	Artiaga,B	SOCR		12:00-1:50PM	F	Caines,T	K 108
	11:30-12:50PM	F	Artiaga,B	SOCR		1:00-1:50PM	W	Caines,T	K 108
26439	7:00-7:15PM	TTh	Gonzalez,R	STAD	25564	3:00-3:50PM	M	Caines,T	K 108
	7:15-7:50PM	TTh	Gonzalez,R	STAD		3:00-3:50PM	W	Caines,T	K 108
PEX 179 - 1.0 UNIT SOCCER, FITNESS AND TECHNIQUE						3:00-4:50PM	F	Caines,T	K 108
Transferable to UC, CSU					25566	9:00-9:30AM	TTh	Caines,T	K 108
25514	1:00-1:30PM	F	Artiaga,B	SOCR		9:30-10:50AM	TTh	Caines,T	K 108
	1:30-2:50PM	F	Artiaga,B	SOCR	25570	1:00-1:30PM	TTh	Grosfeld,S	K 108
25518	1:00-1:30PM	TTh	Artiaga,B	SOCR		1:30-2:50PM	TTh	Grosfeld,S	K 108
	1:30-2:50PM	TTh	Artiaga,B	SOCR	25572	6:00-6:15AM	MTWTh	Gonzalez,R	K 108
Class# 25518 meets 03/24/2020-05/21/2020					25576	6:30-6:45PM	MTWTh	STAFF	K 108
PEX 184 - 1.0 UNIT SWIMMING, NOVICE						6:45-7:20PM	MTWTh	STAFF	K 108
Transferable to UC, CSU					PEX 246 - 2.0 UNITS OLYMPIC WEIGHTS-POWER LIFTING				
25520	2:00-2:15PM	TTh	Abing,J	POOL	Transferable to UC, CSU				
	2:15-2:50PM	TTh	Abing,J	POOL	25578	2:00-2:30PM	MW	Grosfeld,S	K 108
25522	12:00-12:15PM	MW	Abing,J	POOL		2:30-3:50PM	MW	Grosfeld,S	K 108
	12:15-12:50PM	MW	Abing,J	POOL	PEX 249 - 2.0 UNITS TAE KWON DO, INTERMEDIATE/ADVANCED				
25526	10:00-10:15AM	MW	Macias,S	POOL	Transferable to UC, CSU				
	10:15-10:50AM	MW	Macias,S	POOL	26431	10:00-10:30AM	TTh	STAFF	GYM
29762	10:00-10:15AM	TTh	Macias,S	POOL		10:30-11:50AM	TTh	STAFF	GYM
	10:15-10:50AM	TTh	Macias,S	POOL	PEX 261 - 2.0 UNITS BADMINTON, INTERMEDIATE/ADVANCED				
27272	2:00-2:30PM	MW	Abing,J	POOL	Transferable to UC, CSU				
	2:30-3:50PM	MW	Abing,J	POOL	30175	11:00-11:30AM	MW	Jensen,D	FA133
Class# 27272 meets 03/23/2020-05/20/2020						11:30-12:50PM	MW	Jensen,D	CB103
PEX 185 - 1.0 UNIT SWIMMING, BEGINNING					PEX 265 - 2.0 UNITS BASKETBALL, INTERMEDIATE				
Transferable to UC, CSU					Transferable to UC, CSU				
25528	2:00-2:15PM	TTh	Abing,J	POOL	25584	9:00-9:30AM	MW	May,R	GYM
	2:15-2:50PM	TTh	Abing,J	POOL		9:30-10:50AM	MW	May,R	GYM
25530	12:00-12:15PM	MW	Abing,J	POOL	25586	6:00-6:30PM	TTh	May,R	GYM
	12:15-12:50PM	MW	Abing,J	POOL		6:30-7:50PM	TTh	May,R	GYM
25534	10:00-10:15AM	MW	Macias,S	POOL	28988	3:00-3:30PM	MTWTh	May,R	GYM
	10:15-10:50AM	MW	Macias,S	POOL		3:30-5:50PM	MTWTh	May,R	GYM
29764	10:00-10:15AM	TTh	Macias,S	POOL	Class# 28988 meets 03/23/2020-05/21/2020				
	10:15-10:50AM	TTh	Macias,S	POOL	PEX 266 - 2.0 UNITS BASKETBALL, ADVANCED				
27274	2:00-2:30PM	MW	Abing,J	POOL	Transferable to UC, CSU				
	2:30-3:50PM	MW	Abing,J	POOL	25588	9:00-9:30AM	MW	May,R	GYM
Class# 27274 meets 03/23/2020-05/20/2020						9:30-10:50AM	MW	May,R	GYM
PEX 188 - 1.0 UNIT TENNIS, INTRODUCTION					25590	6:00-6:30PM	TTh	May,R	GYM
Transferable to UC, CSU						6:30-7:50PM	TTh	May,R	GYM
29770	9:00-9:15AM	MW	STAFF	CTS	28990	3:00-3:30PM	MTWTh	May,R	GYM
	9:15-9:50AM	MW	STAFF	CTS		3:30-5:50PM	MTWTh	May,R	GYM
PEX 189 - 1.0 UNIT TENNIS, BEGINNING					Class# 28990 meets 03/23/2020-05/21/2020				
Transferable to UC, CSU					PEX 267 - 2.0 UNITS BOWLING, INTERMEDIATE/ADVANCED				
29772	9:00-9:15AM	MW	STAFF	CTS	Transferable to UC, CSU				
	9:15-9:50AM	MW	STAFF	CTS	27236	11:00-11:30AM	F	STAFF	K 108
PEX 191 - 1.0 UNIT VOLLEYBALL, INTRODUCTION						+ 3.0 HRS ARR		STAFF	K 108
Transferable to UC, CSU						11:30-12:50PM	F	STAFF	K 108
25544	8:00-8:15AM	TTh	STAFF	GYM	PEX 276 - 2.0 UNITS GOLF, INTERMEDIATE/ADVANCED				
	8:15-8:50AM	TTh	STAFF	GYM	Transferable to UC, CSU				
27031	6:30-7:00PM	M	STAFF	GYM	25592	9:00-10:00AM	F	Caines,T	K 108
	7:00-8:20PM	M	STAFF	GYM		+ 3.0 HRS ARR		Caines,T	K 108
PEX 192 - 1.0 UNIT VOLLEYBALL, BEGINNING						10:00-10:50AM	F	Caines,T	K 108
Transferable to UC, CSU					PEX 278 - 2.0 UNITS SOCCER, INTERMEDIATE/ADVANCED				
25546	8:00-8:15AM	TTh	STAFF	GYM	Transferable to UC, CSU				
	8:15-9:15AM	TTh	STAFF	GYM	25594	9:00-9:30AM	MW	Artiaga,B	SOCR
27033	6:30-7:00PM	M	STAFF	GYM		9:30-10:50AM	MW	Artiaga,B	SOCR
	7:00-8:20PM	M	STAFF	GYM	25596	7:00-7:30PM	TTh	Gonzalez,R	STAD
						7:30-8:50PM	TTh	Gonzalez,R	STAD

Students not in attendance or late for the first class meeting are subject to drop.

PHYSICS

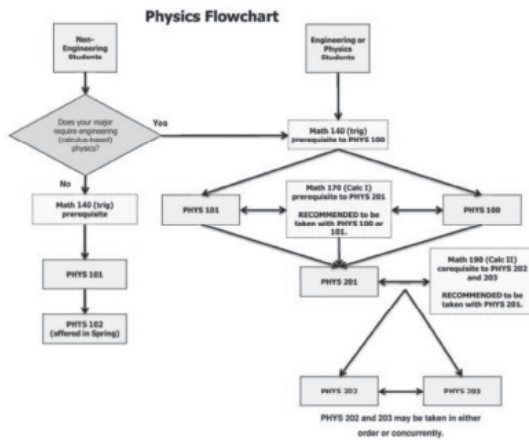

PHYS 100 - 4.0 UNITS ELEMENTARY PHYSICS

Transferable to UC, CSU
Prerequisite: MATH 140 or equivalent with a grade of "C" or higher or "Pass" or completion of the math placement process with a score eligible for MATH 155.

20658	11:00-12:15PM	MW	Patra,S	S 104
20659	1:00-3:50PM	M	Patra,S	PST124

Attendance to the first Lab meeting is MANDATORY. Failure to attend will jeopardize your enrollment.

20983	1:00-3:50PM	W	Patra,S	PST124
-------	-------------	---	---------	--------

Attendance to the first Lab meeting is MANDATORY. Failure to attend will jeopardize your enrollment.

PHYS 101 - 4.0 UNITS GENERAL PHYSICS

Transferable to UC, CSU (CAN PHYS 2)(CAN PHYS SEQ A)
Prerequisite: MATH 140 or equivalent with a grade of "C" or higher or "Pass."

20660	11:00-12:15PM	MW	McLarty-Schroeder,J	PST124
21852	2:00-4:50PM	F	Mera,C	PST133

Attendance to the first Lab meeting is MANDATORY. Failure to attend will jeopardize your enrollment.

20661	7:00-9:50PM	M	Said,A	PST133
-------	-------------	---	--------	--------

Attendance to the first Lab meeting is MANDATORY. Failure to attend will jeopardize your enrollment.

23660	5:30-6:45PM	MW	Said,A	S 104
23661	7:00-9:50PM	W	Said,A	PST124

Attendance to the first Lab meeting is MANDATORY. Failure to attend will jeopardize your enrollment.

PHYS 102 - 4.0 UNITS GENERAL PHYSICS

Transferable to UC, CSU (CAN PHYS 4)(CAN PHYS SEQ A)
Prerequisite: PHYS 101 or equivalent with a grade of "C" or higher or "Pass."

21566	5:30-6:45PM	MW	Takemae,S	PST124
21568	7:00-9:50PM	M	Takemae,S	PST124

Attendance to the first Lab meeting is MANDATORY. Failure to attend will jeopardize your enrollment.

PHYS 201 - 4.0 UNITS ENGINEERING PHYSICS

Transferable to UC, CSU (CAN PHYS 8)(CAN PHYS SEQ B)
Prerequisite: PHYS 100 or PHYS 101 and MATH 170 or equivalents with grades of "C" or higher or "Pass."

28951	12:30-1:45PM	TTh	Said,A	S 104
28952	2:00-4:50PM	T	Said,A	PST133

Attendance to the first Lab meeting is MANDATORY. Failure to attend will jeopardize your enrollment.

29677	2:00-4:50PM	Th	Said,A	PST133
-------	-------------	----	--------	--------

Attendance to the first Lab meeting is MANDATORY. Failure to attend will jeopardize your enrollment.

20984	5:30-7:20PM	TThF	Mera,C	PST133
20986	7:20-9:20PM	TThF	Mera,C	PST133

Attendance to the first Lab meeting is MANDATORY. Failure to attend will jeopardize your enrollment.

Class# 20984 meets 01/14/2020-03/12/2020

PHYS 202 - 4.0 UNITS ENGINEERING PHYSICS

Transferable to UC, CSU (CAN PHYS 12)(CAN PHYS SEQ B)
Prerequisite: PHYS 201 and MATH 170 or equivalents with grades of "C" or higher or "Pass."

Corequisite: MATH 190 or prior completion of MATH 190 or equivalent with a grade of "C" or higher or "Pass."

22206	2:00-3:15PM	TTh	Buschauer,R	S 104
22207	3:30-6:20PM	T	Buschauer,R	PST124

Attendance to the first Lab meeting is MANDATORY. Failure to attend will jeopardize your enrollment.

28155	11:00-1:50PM	Th	Buschauer,R	PST133
-------	--------------	----	-------------	--------

Attendance to the first Lab meeting is MANDATORY. Failure to attend will jeopardize your enrollment.

PHYS 203 - 4.0 UNITS ENGINEERING PHYSICS

Transferable to UC, CSU (CAN PHYS 14)(CAN PHYS SEQ B)
Prerequisite: PHYS 201 and MATH 170 or equivalents with grades of "C" or higher or "Pass."

Corequisite: MATH 190 or prior completion of MATH 190 or equivalent with a grade of "C" or higher or "Pass."

28692	5:30-7:20PM	TThF	Mera,C	PST133
-------	-------------	------	--------	--------

Attendance to the first Lab meeting is MANDATORY. Failure to attend will jeopardize your enrollment.

28693	7:20-9:20PM	TThF	Mera,C	PST133
-------	-------------	------	--------	--------

PLASTICS/COMPOSITES MANUFACTURING TECHNOLOGY

PMT 51 - 2.5 UNITS COMPOSITES FABRICATION

Not Transferable
Recommendation: PMT 70 or equivalent with a grade of "C" or higher or "Pass" or appropriate work experience. Please read the technical standards relevant to this department at <https://www.cerritos.edu/technology/standards.htm>.

27820	6:00-8:00PM	TTh	Fitzgerald,B	ME 1
	8:00-9:50PM	TTh	Fitzgerald,B	ME 1

Class# 27820 meets 01/14/2020-03/12/2020

PMT 53 - 3.0 UNITS COMPOSITES REPAIR

Not Transferable
Recommendation: PMT 70 or equivalent with a grade of "C" or higher or "Pass" or appropriate work experience.

29608	6:00-9:00PM	W	O'Farrell,F	ME 1
	9:00-9:50PM	W	O'Farrell,F	ME 1

PMT 59 - 2.5 UNITS INJECTION MOLDING I

28656	6:00-8:00PM	F	Mendoza,L	PST230
	8:00-9:50PM	F	Mendoza,L	ME 1

PMT 72 - 2.5 UNITS TOOLING FOR PLASTICS

Not Transferable
Recommendation: PMT 61, PMT 67, PMT 70 or equivalent with a grade of "C" or higher or "Pass".

28965	6:00-8:00PM	TTh	Fitzgerald,B	ME 1
	8:00-9:50PM	TTh	Fitzgerald,B	ME 1

Class# 28965 meets 03/24/2020-05/21/2020

PMT 100 - 2.5 UNITS PLASTICS TECHNOLOGY

21774	6:00-8:00PM	M	Li,D	ME 1
	8:00-9:50PM	M	Li,D	ME 1

Class#	Time	Day	Instructor	Room	Class#	Time	Day	Instructor	Room
POLITICAL SCIENCE					22640	9:30-1:00PM	F	Susuki,D	SS313
					Class# 22640 meets 02/07/2020-05/22/2020				
27281	6.0 HRS ARR	(OL)	STAFF	ONLINE	Orientation will be conducted online. Instructor will email instructions to enrolled students one week before the start of class.				
					Class# 27281 meets 03/23/2019-05/24/2019				
					POL 201 - 3.0 UNITS INTRODUCTION TO POLITICAL SCIENCE AND AMERICAN GOVERNMENT				
					Transferable to UC, CSU				
					Recommendation: Satisfactory completion of the English Placement Process or ENGL 52 or equivalent with a grade of "C" or higher or "Pass" and satisfactory completion of the Reading Placement Process or READ 54 with a grade of "C" or higher or "Pass".				
23348	3.0 HRS ARR	(OL)	STAFF	ONLINE	22560	12:30-1:45PM	TTh	Mullins,T	SS212
Orientation will be conducted online. Instructor will email instructions to enrolled students one week before the start of class.					27722	3:30-4:45PM	MW	Mullins,T	SS314
20662	3.0 HRS ARR	(OL)	Falcon,D	ONLINE	POL 210 - 3.0 UNITS INTERNATIONAL RELATIONS				
Note: Visit www.cerritos.edu/dfalcon and follow all instructions on that site no later than midnight of the second day of the semester to satisfy the orientation requirement for this class. Students failing to do this may be dropped as no show.					Transferable to UC, CSU				
20663	9:30-10:45AM	MW	Obazuaye,S	SS308	Recommendation: Satisfactory completion of the English Placement Process or ENGL 52 or equivalent with a grade of "C" or higher or "Pass" and satisfactory completion of the Reading Placement Process or READ 54 or equivalent with a grade of Pass or "C" or higher.				
20664	12:30-1:45PM	MW	Obasohan,V	SS313	21981	6:00-8:50PM	Th	McBride,L	SS308
20665	11:00-12:15PM	MW	Obasohan,V	SS313	POL 230 - 3.0 UNITS CONTEMP POL PROB-MID EAST				
20666	11:00-12:15PM	MW	Falcon,D	SS307	Transferable to UC, CSU				
20667	11:00-12:15PM	MW	Obazuaye,S	SS308	30222	6:00-8:50PM	W	Obazuaye,S	SS308
20668	9:30-10:45AM	TTh	Obasohan,V	SS313	POL 240 - 3.0 UNITS INTRODUCTION TO POLITICAL THEORY				
20669	9:30-10:45AM	MW	Falcon,D	SS307	Transferable to UC, CSU				
23349	3.0 HRS ARR	(OL)	Mullins,T	ONLINE	Recommendation: Completion of the English Placement Process with a score eligible for ENGL 52 or ENGL 100 or equivalent with a grade of "C" or higher or "Pass" and completion of the Reading Placement Process with a score eligible for READ 100 or READ 54 or equivalent with a grade of "C" or higher or "Pass".				
Orientation will be conducted online. Instructor will email instructions to enrolled students one week before the start of class.					23356	6:00-8:50PM	T	Mullins,T	SS308
23350	7:00-9:50PM	M	McBride,L	SS313	POL 250 - 3.0 UNITS MODEL UNITED NATIONS THEORY AND PRACTICE				
20670	12:30-1:45PM	TTh	Obasohan,V	SS313	Transferable to CSU				
20671	12:30-1:45PM	TTh	Falcon,D	SS307	Recommendation: Completion of ENGL 52, or ENGL 72, or ESL 152, or equivalent with a grade of "C" or higher, or "Pass," or completion of the placement process with eligibility for ENGL 100 and READ 54 with a grade of "C" or higher or "Pass," and completion of the placement process with a score sufficient to meet the A.				
20672	2:00-3:15PM	TTh	Obasohan,V	SS313	25699	6:00-8:50PM	M	Obazuaye,S	SS308
20990	5:30-6:45PM	MW	Obasohan,V	SS313	PSYCHOLOGY				
23352	7:00-9:50PM	Th	STAFF	SS313	PSYC 101 - 3.0 UNITS GENERAL INTRODUCTORY PSYCHOLOGY				
20991	3.0 HRS ARR	(OL)	Obazuaye,S	ONLINE	Transferable to UC, CSU (CAN PSY 2)				
Mandatory on-campus orientation on Friday, January 17 from 10:00am - 12:00pm in HS 102 (Health Science Building, Room 102). You must attend to stay in the class.					20673	8:00-9:15AM	MW	STAFF	SS214
20992	2:00-3:15PM	TTh	Mullins,T	SS308	20674	12:30-1:45PM	TTh	St. John,H	SS214
23353	9:30-10:45AM	MW	Morrione,D	SS313	20675	9:30-10:45AM	MW	STAFF	SS214
21651	3.0 HRS ARR	(OL)	Mullins,T	ONLINE	20678	12:30-1:45PM	MW	STAFF	SS214
Orientation will be conducted online. Instructor will email instructions to enrolled students one week before the start of class.					20679	11:00-12:15PM	MW	STAFF	SS214
22624	3.0 HRS ARR	(OL)	Obazuaye,S	ONLINE	20682	9:30-10:45AM	TTh	STAFF	SS214
Mandatory on-campus orientation on Friday, January 17 from 10:00am - 12:00pm in HS 102 (Health Science Building, Room 102). You must attend to stay in the class.					20683	11:00-12:15PM	TTh	STAFF	SS214
27280	3.0 HRS ARR	(OL)	Gaffaney,G	ONLINE	20680	6.0 HRS ARR	(OL)	Duff,K	ONLINE
Orientation will be conducted online. Instructor will email instructions to enrolled students one week before the start of class.					There is no on campus orientation; course is 100% online. Instructor will email students with course information on the first day of the semester; information will also be posted in Canvas, available through the Cerritos College website. Students must be online by midnight of the first day of class. Waitlist students will be emailed by instructor if they can be added.				
21550	3.0 HRS ARR	(OL)	Falcon,D	ONLINE	Class# 20680 meets 01/13/2020-03/13/2020				
Note: Visit www.cerritos.edu/dfalcon and follow all instructions on that site no later than midnight of the second day of the semester to satisfy the orientation requirement for this class. Students failing to do this may be dropped as no show.					20681	6.0 HRS ARR	(OL)	St. John,H	ONLINE
21551	3.0 HRS ARR	(OL)	Mosley,Y	ONLINE	There is no on campus orientation; course is 100% online. Instructor will email students with course information on the first day of the semester; information will also be posted in Canvas, available through the Cerritos College website. Students must be online by midnight of the first day of class. Waitlist students will be emailed by instructor if they can be added.				
Orientation will be conducted online. Instructor will email instructions to enrolled students one week before the start of class.					Class# 20681 meets 01/13/2020-03/13/2020				
21553	3.0 HRS ARR	(OL)	Falcon,D	ONLINE	PSYC 101 - 3.0 UNITS GENERAL INTRODUCTORY PSYCHOLOGY				
Note: Visit www.cerritos.edu/dfalcon and follow all instructions on that site no later than midnight of the second day of the semester to satisfy the orientation requirement for this class. Students failing to do this may be dropped as no show.					Transferable to UC, CSU (CAN PSY 2)				
26385	11:00-12:15PM	TTh	STAFF	SS313	20673	8:00-9:15AM	MW	STAFF	SS214
26386	5:30-6:45PM	TTh	Williams-Manser,D	SS313	20674	12:30-1:45PM	TTh	St. John,H	SS214
21652	8:00-9:15AM	MW	Morrione,D	SS313	20675	9:30-10:45AM	MW	STAFF	SS214
27282	9:30-10:45AM	TTh	Falcon,D	SS308	20678	12:30-1:45PM	MW	STAFF	SS214
28664	2:00-3:15PM	MW	Mullins,T	SS313	20679	11:00-12:15PM	MW	STAFF	SS214
24186	3.6 HRS ARR	(OL)	Mosley,Y	ONLINE	20682	9:30-10:45AM	TTh	STAFF	SS214
Orientation will be conducted online. Instructor will email instructions to enrolled students one week before the start of class.					20683	11:00-12:15PM	TTh	STAFF	SS214
Class# 24186 meets 02/03/2020-05/22/2020					20680	6.0 HRS ARR	(OL)	Duff,K	ONLINE
27323	3.6 HRS ARR	(OL)	STAFF	ONLINE	There is no on campus orientation; course is 100% online. Instructor will email students with course information on the first day of the semester; information will also be posted in Canvas, available through the Cerritos College website. Students must be online by midnight of the first day of class. Waitlist students will be emailed by instructor if they can be added.				
Orientation will be conducted online. Instructor will email instructions to enrolled students one week before the start of class.					Class# 20680 meets 01/13/2020-03/13/2020				
Class# 27323 meets 02/03/2020-05/22/2020					20681	6.0 HRS ARR	(OL)	St. John,H	ONLINE
23355	7:00-10:20PM	T	Williams-Manser,D	SS313	There is no on campus orientation; course is 100% online. Instructor will email students with course information on the first day of the semester; information will also be posted in Canvas, available through the Cerritos College website. Students must be online by midnight of the first day of class. Waitlist students will be emailed by instructor if they can be added.				
Class# 23355 meets 02/04/2020-05/19/2020					Class# 20681 meets 01/13/2020-03/13/2020				
20993	7:00-10:20PM	W	Banks,C	SS313	PSYCHOLOGY				
Class# 20993 meets 02/05/2020-05/20/2020					PSYC 101 - 3.0 UNITS GENERAL INTRODUCTORY PSYCHOLOGY				

Students not in attendance or late for the first class meeting are subject to drop.

Class#	Time	Day	Instructor	Room	Class#	Time	Day	Instructor	Room
28581	6.0 HRS ARR	(OL)	STAFF	ONLINE	PSYC 220 - 4.0 UNITS RESEARCH METHODS Transferable to UC, CSU (CAN PSY 8) Prerequisite: PSYC 101 and PSYC 210 or equivalent with a grade of "Pass" or "C" or higher. Recommendation: ENGL 52 or equivalent with a grade of "Pass" or "C" or higher.				
21554	6.0 HRS ARR	(OL)	Lewellen,R	ONLINE	21000	6:30-8:00PM	MW	STAFF	SS215
20684	6.0 HRS ARR	(OL)	Duff,K	ONLINE	21951	8:00-9:20PM	MW	STAFF	SS215
20995	6.0 HRS ARR	(OL)	St. John,H	ONLINE	21951	5:00-6:30PM	TTh	St. John,H	SS215
20685	12:30-1:45PM	MW	STAFF	BE110	21951	6:30-7:50PM	TTh	St. John,H	SS215
20686	5:00-6:15PM	MW	STAFF	BE110	27465	12:30-2:00PM	TTh	Ronquillo-Adachi,J	SS215
26387	11:00-12:15PM	MW	STAFF	BE110	27465	2:00-3:20PM	TTh	Ronquillo-Adachi,J	SS215
20687	12:30-1:45PM	TTh	STAFF	BE111	PSYC 241 - 3.0 UNITS INTRODUCTION TO PSYCHOBIOLOGY Transferable to UC, CSU Prerequisite: PSYC 101 or equivalent with a grade of "C" or higher or "Pass."				
21855	6:30-9:20PM	Th	STAFF	BE110	20693	11:00-12:15PM	TTh	STAFF	SS213
27225	11:00-12:15PM	TTh	STAFF	BE109	27090	6:00-8:50PM	T	Lewellen,R	SS213
B27387	6:30-9:20PM	W	STAFF	BE110	22634	6.0 HRS ARR	(OL)	Lewellen,R	ONLINE
27423	9:30-10:45AM	MW	STAFF	BE111	There is no on campus orientation. Orientation is done online and must be done on the first day of class. Instructor will email students with course information one week prior to the start of the semester. All classwork is done online. Email: rlewellen@cerritos.edu Class# 22634 meets 03/23/2019-05/24/2019				
27723	8:00-9:15AM	TTh	STAFF	BE110	PSYC 245 - 3.0 UNITS DRUGS AND BEHAVIOR Transferable to UC, CSU				
27724	2:00-3:15PM	TTh	STAFF	BE109	26999	12:30-1:45PM	TTh	STAFF	BE116
29031	11:00-12:15PM	TTh	STAFF	BE111	PSYC 251 - 3.0 UNITS DEVELOPMENTAL PSYCHOLOGY Transferable to UC, CSU				
PSYC 103 - 3.0 UNITS CRITICAL THINKING IN PSYCHOLOGY Transferable to UC, CSU Prerequisite: ENGL 100 or equivalent with a grade of "C" or higher or "Pass".					21003	6:30-9:20PM	M	STAFF	SS312
20685	12:30-1:45PM	MW	STAFF	BE110	21555	9:30-10:45AM	MW	STAFF	SS139
20686	5:00-6:15PM	MW	STAFF	BE110	21556	2:00-3:15PM	TTh	STAFF	SS312
26387	11:00-12:15PM	MW	STAFF	BE110	22457	12:30-1:45PM	MW	STAFF	SS212
20687	12:30-1:45PM	TTh	STAFF	BE111	23361	6:30-9:20PM	W	STAFF	SS213
21855	6:30-9:20PM	Th	STAFF	BE110	26388	2:00-3:15PM	MW	STAFF	SS312
27225	11:00-12:15PM	TTh	STAFF	BE109	27725	12:30-1:45PM	TTh	STAFF	BE117
B27387	6:30-9:20PM	W	STAFF	BE110	PSYC 261 - 3.0 UNITS SOCIAL PSYCHOLOGY Transferable to UC, CSU				
27423	9:30-10:45AM	MW	STAFF	BE111	22302	12:30-1:45PM	TTh	Duff,K	SS213
27723	8:00-9:15AM	TTh	STAFF	BE110	25692	9:30-10:45AM	TTh	Duff,K	SS213
27724	2:00-3:15PM	TTh	STAFF	BE109	29703	6.0 HRS ARR	(OL)	Duff,K	ONLINE
29031	11:00-12:15PM	TTh	STAFF	BE111	There is no on campus orientation; course is 100% online. Instructor will email students with course information on the first day of the semester; information will also be posted in Canvas, available through the Cerritos College website. Students must be online by midnight of the first day of class. Waitlist students will be emailed by instructor if they can be added. Class# 29703 meets 01/13/2020-03/13/2020				
PSYC 150 - 3.0 UNITS PERSONAL AND SOCIAL ADJUSTMENT Transferable to UC, CSU Recommendation: PSYC 101 and ENGL 52 or equivalent with grades or "Pass" or "C" or higher.					PSYC 265 - 3.0 UNITS PSYCHOLOGY OF GENDER Transferable to UC, CSU				
20688	12:30-1:45PM	TTh	STAFF	SS140	27726	2:00-3:30PM	MW	STAFF	SS139
28769	12:30-3:20PM	W	Sanchez,V	SS213	Class# 27726 meets 02/03/2020-05/22/2020				
PSYC 210 - 4.0 UNITS ELEMENTARY STATISTICS Transferable to UC, CSU (CAN PSY 6) Prerequisite: MATH 75 or MATH 80 or equivalent with a grade of "C" or higher or "Pass" or satisfactory completion of the assessment/placement process with eligibility for PSYC 210.					PSYC 271 - 3.0 UNITS ABNORMAL PSYCHOLOGY Transferable to UC, CSU Recommendation: ENGL 52 or equivalent with a grade of "C" or higher or "Pass", and READ 54 or equivalent with a grade of "C" or higher or "Pass".				
20689	8:00-9:30AM	TTh	Ronquillo-Adachi,J (Honors Section)	SS215	20696	9:30-10:45AM	TTh	STAFF	SS315
20691	9:30-10:50AM	TTh	Ronquillo-Adachi,J (Honors Section)	SS215	21004	6:30-9:20PM	T	STAFF	SS140
20691	3:30-5:00PM	MW	STAFF	SS215	PSYC 273 - 3.0 UNITS MENTAL HEALTH WORKER FIELD EXPERIENCE Transferable to CSU Prerequisite: INST 151, INST 152, PSYC 101, and PSYC 271, with a grade of "C" or higher or "Pass". Corequisite: INST 272 with a grade of "C" or higher or "Pass".				
20998	5:00-6:20PM	MW	STAFF	SS215	25693	5:00-5:50PM	Th	Maldonado,C	BE110
20998	9:30-11:00AM	MW	STAFF	SS215	+ 6.0 HRS ARR Maldonado,C				
23359	11:00-12:20PM	MW	STAFF	SS215					
23359	3:30-5:00PM	TTh	Sanchez,V	MP202					
23359	5:00-6:20PM	TTh	Sanchez,V	MP202					
28770	12:30-2:00PM	MW	STAFF	MP202					
28770	2:00-3:20PM	MW	STAFF	MP202					
28097	9:30-11:00AM	MW	STAFF	MP202					
28097	11:00-12:20PM	MW	STAFF	MP202					
28582	12:30-2:00PM	TTh	Sanchez,V	MP202					
28582	2:00-3:20PM	TTh	Sanchez,V	MP202					
28772	6:30-8:00PM	MW	STAFF	MP202					
28772	8:00-9:20PM	MW	STAFF	MP202					
29073	9:30-11:00AM	TTh	STAFF	MP202					
29073	11:00-12:20PM	TTh	STAFF	MP202					
29075	6:30-8:00PM	TTh	STAFF	MP202					
29075	8:00-9:20PM	TTh	STAFF	MP202					
29699	3:30-5:00PM	MW	STAFF	MP202					
29699	5:00-6:20PM	MW	STAFF	MP202					
29701	12:30-2:00PM	MW	STAFF	SS215					
29701	2:00-3:20PM	MW	STAFF	SS215					

Students not in attendance or late for the first class meeting are subject to drop.

Class#	Time	Day	Instructor	Room	Class#	Time	Day	Instructor	Room
--------	------	-----	------------	------	--------	------	-----	------------	------

SOCIOLOGY

SOC 101 - 3.0 UNITS INTRODUCTORY SOCIOLOGY PRINCIPLES

Transferable to UC, CSU (CAN SOC 2)

22322	5:30-6:45PM	MW	STAFF	SS316
23363	8:00-9:15AM	TTh	Tshako,J	SS314
20717	9:30-10:45AM	MW	Tshako,J	SS314
20718	7:00-9:50PM	T	Der-Mesropian,E	SS314
22619	11:00-12:15PM	TTh	Ysais,M	SS314
20719	11:00-12:15PM	MW	Dunn,M	SS314
20720	9:30-10:45AM	TTh	Dunn,M	SS314
20721	12:30-1:45PM	TTh	Dunn,M	SS314
21557	2:00-3:15PM	MW	Smart,B	SS314
22260	12:30-1:45PM	MW	Tshako,J	SS316
25771	12:30-2:00PM	MW	Holzgang,A	SS138
Class# 25771 meets 02/03/2020-05/20/2020				
24192	2:00-3:30PM	TTh	Holzgang,A	SS316
Class# 24192 meets 02/04/2020-05/21/2020				
29187	6.0 HRS ARR	(OL)	STAFF	ONLINE
Class# 29187 meets 03/23/2019-05/24/2019				

SOC 110 - 3.0 UNITS MARRIAGE AND THE FAMILY

Transferable to UC, CSU

20722	2:00-3:15PM	TTh	Dunn,M	SS314
28665	12:30-1:45PM	MW	Dunn,M	SS314
21022	5:30-7:00PM	TTh	Der-Mesropian,E	SS314
Class# 21022 meets 02/04/2020-05/21/2020				

SOC 120 - 3.0 UNITS INTRODUCTION TO HUMAN SEXUALITY

Transferable to UC, CSU

20725	12:30-1:45PM	MW	Smart,B	SS315
20726	3:30-4:45PM	TTh	Ysais,M	SS314

SOC 201 - 3.0 UNITS SOCIAL PROBLEMS

Transferable to UC, CSU (CAN SOC 4)

Recommendation: SOC 101 or equivalent with a grade of "C" or higher or "Pass".

22458	12:30-1:45PM	TTh	Tshako,J	SS316
28667	2:00-3:15PM	MW	Tshako,J	SS316

SOC 202 - 3.0 UNITS GENDER AND SOCIETY

Transferable to UC, CSU

Recommendation: SOC 101 or WGS 101 with a grade of "C" or higher or "Pass".

28953	7:00-9:50PM	W	Gregg,H	SS138
28037	2:00-3:30PM	MW	Holzgang,A	SS138
Class# 28037 meets 02/03/2020-05/20/2020				
24193	12:30-2:00PM	TTh	Holzgang,A	SS138
Class# 24193 meets 02/04/2020-05/21/2020				

SOC 205 - 3.0 UNITS INTRODUCTION TO SOCIAL RESEARCH METHODS

Transferable to UC, CSU

Prerequisite: SOC 101 or ANTH 100 or equivalent with a grade of "C" or higher or "Pass".

Recommendation: ENGL 100 or equivalent and MATH 80 or equivalent with grades of Pass or "C" or higher.

22304	9:30-11:00AM	TTh	Holzgang,A	BE106
Class# 22304 meets 02/04/2020-05/21/2020				

SOC 210 - 3.0 UNITS AMERICAN MINORITY RELATIONS

Transferable to UC, CSU

Recommendation: SOC 101 or equivalent with a grade of "C" or higher or "Pass".

28038	5:30-6:45PM	MW	Smart,B	SS137
-------	-------------	----	---------	-------

SOC 215 - 3.0 UNITS SOCIOLOGY OF CULTURAL DIVERSITY: CHALLENGE AND CHANGE

Transferable to UC, CSU

29710	2:00-3:15PM	TTh	Tshako,J	SS137
-------	-------------	-----	----------	-------

SOC 220 - 3.0 UNITS INTRODUCTION TO HUMAN SERVICES

Transferable to CSU

Recommendation: SOC 101 or PSYC 101 or equivalent with a grade of "C" or higher or "Pass" is strongly recommended.

22218	7:00-10:05PM	M	STAFF	SS309
-------	--------------	---	-------	-------

SOC 298 - 1.0 UNIT DIRECTED STUDIES

Transferable to CSU

26865	3.6 HRS ARR	STAFF		
Class# 26865 meets 02/03/2020-05/22/2020				

SPANISH

SPAN 101 - 5.0 UNITS ELEMENTARY SPANISH

Transferable to UC, CSU (CAN SPAN 2)

20728	8:30-10:45AM	MW	Cabuto,F	LA212
			+ 1.0 HRS ARR	Cabuto,F
LAB IS ONE HOUR PER WEEK IN THE SUCCESS CENTER				
20729	8:00-10:15AM	MW	Ugalde,M	LA210
			+ 1.0 HRS ARR	Ugalde,M
LAB IS ONE HOUR PER WEEK IN THE SUCCESS CENTER				
23429	11:00-1:15PM	TTh	STAFF	LC134
			+ 1.0 HRS ARR	STAFF
LAB IS ONE HOUR PER WEEK IN THE SUCCESS CENTER				
26476	11:00-1:15PM	MW	Cabuto,F	LA212
			+ 1.0 HRS ARR	Cabuto,F
LAB IS ONE HOUR PER WEEK IN THE SUCCESS CENTER				
22631	12:30-2:45PM	TTh	STAFF	CB103
			+ 1.0 HRS ARR	STAFF
LAB IS ONE HOUR PER WEEK IN THE SUCCESS CENTER				
20731	2:00-4:15PM	TTh	STAFF	SS214
			+ 1.0 HRS ARR	STAFF
LAB IS ONE HOUR PER WEEK IN THE SUCCESS CENTER				
21025	3:30-5:45PM	MW	STAFF	LC213
			+ 1.0 HRS ARR	STAFF
LAB IS ONE HOUR PER WEEK IN THE SUCCESS CENTER				
21026	4:30-6:45PM	TTh	STAFF	LA210
			+ 1.0 HRS ARR	STAFF
LAB IS ONE HOUR PER WEEK IN THE SUCCESS CENTER				
21027	10:30-12:15PM	MW	STAFF	HS103
			+ 1.0 HRS ARR	STAFF
LAB IS ONE HOUR PER WEEK IN THE SUCCESS CENTER				
22266	7:00-9:15PM	TTh	Cifuentes,O	SS214
			+ 1.0 HRS ARR	Cifuentes,O
LAB IS ONE HOUR PER WEEK IN THE SUCCESS CENTER				
26244	7:00-9:15PM	MW	Cifuentes,O	LA209
			+ 1.0 HRS ARR	Cifuentes,O
LAB IS ONE HOUR PER WEEK IN THE SUCCESS CENTER				
27771	3:00-5:15PM	MW	STAFF	LC217
			+ 1.0 HRS ARR	STAFF
LAB IS ONE HOUR PER WEEK IN THE SUCCESS CENTER				
29000	7:00-9:15PM	TTh	STAFF	SS224
			+ 1.0 HRS ARR	STAFF
LAB IS ONE HOUR PER WEEK IN THE SUCCESS CENTER				
27107	8:00-1:20PM	Sat	STAFF	LA210
			+ 1.1 HRS ARR	STAFF
LAB IS ONE HOUR PER WEEK IN THE SUCCESS CENTER				
Class# 27107 meets 01/18/2020-05/16/2020				

SPAN 102 - 5.0 UNITS ELEMENTARY SPANISH

Transferable to UC, CSU (CAN SPAN 4)

Prerequisite: SPAN 101 or SPAN 103B or SPAN 111 or equivalent with a grade of "C" or higher or "Pass".

20732	4:00-6:15PM	MW	STAFF	LA109
			+ 1.0 HRS ARR	STAFF
LAB IS ONE HOUR PER WEEK IN THE SUCCESS CENTER				
22440	4:30-6:45PM	TTh	STAFF	LA109
			+ 1.0 HRS ARR	STAFF
LAB IS ONE HOUR PER WEEK IN THE SUCCESS CENTER				
28143	8:00-1:20PM	Sat	STAFF	LA106
			+ 1.1 HRS ARR	STAFF
LAB IS ONE HOUR PER WEEK IN THE SUCCESS CENTER				
Class# 28143 meets 01/18/2020-05/16/2020				

SPAN 111 - 5.0 UNITS ELEMENTARY SPANISH FOR SPANISH SPEAKERS

Transferable to UC, CSU

20733	8:30-10:45AM	TTh	Ugalde,M	LC134
			+ 1.0 HRS ARR	STAFF
LAB IS ONE HOUR PER WEEK IN THE SUCCESS CENTER				
20734	12:30-2:45PM	TTh	Ugalde,M	LA210
			+ 1.0 HRS ARR	Ugalde,M
LAB IS ONE HOUR PER WEEK IN THE SUCCESS CENTER				
21028	10:00-12:15PM	MW	STAFF	HS104
			+ 1.0 HRS ARR	STAFF
LAB IS ONE HOUR PER WEEK IN THE SUCCESS CENTER				
23431	8:30-10:45AM	TTh	STAFF	CB103
			+ 1.0 HRS ARR	STAFF
LAB IS ONE HOUR PER WEEK IN THE SUCCESS CENTER				

Students not in attendance or late for the first class meeting are subject to drop.

Class#	Time	Day	Instructor	Room	Class#	Time	Day	Instructor	Room
SPAN 112 - 5.0 UNITS ELEMENTARY SPANISH FOR SPANISH SPEAKERS Transferable to UC, CSU Prerequisite: SPAN 101 or SPAN 111 or SPAN 103B or equivalent with a grade of "C" or higher or "Pass". LAB IS ONE HOUR PER WEEK IN THE SUCCESS CENTER					SLP 235 - 5.0 UNITS ADULT DISORDERS AND TREATMENT Transferable to CSU Prerequisite: Completion of SLP 125 with a grade of "C" or better, or equivalent.				
21917	10:30-12:45PM	MW	Ugalde,M Ugalde,M	LA210 LC205	29560	6:00-8:00PM 8:00-9:15PM	MW MW	Oh,S Oh,S	SL109 SL109
SPAN 201 - 5.0 UNITS INTERMEDIATE SPANISH Transferable to UC, CSU (CAN SPAN 8) Prerequisite: SPAN 102 or SPAN 112 or equivalent with a grade of "C" or higher or "Pass". LAB IS ONE HOUR PER WEEK IN THE SUCCESS CENTER					Enrollment in SLP 241 and SLP 246 is contingent upon department approval. All placements are done by the instructor and require the student to be available Monday – Friday during regular business hours. On the first Thursday of the 18-week calendar, students are required to attend a mandatory orientation and submit all required documentation as stated in the SLPA Handbook and listed on the website under Field Placements" at www.cerritos.edu/slua. Resume clearance of an interview a criminal background check and/ or drugs of abuse testing may be required prior to clinical field experience and are the responsibility of the student. Students are responsible for their own transportation to and from their clinical placements."				
20736	4:30-6:45PM	TTh	Hernandez,I Hernandez,I	LA213 LC205	SLP 241 - 2.5 UNITS CLINICAL EXPERIENCE I Transferable to CSU Prerequisite: SLP 108, and SLP 125, or equivalent with grades of "C" or higher or "Pass." + 4.5 HRS ARR				
SPAN 202 - 4.0 UNITS INTERMEDIATE SPANISH Transferable to UC, CSU (CAN SPAN 10) Prerequisite: SPAN 201 or equivalent with a grade of "C" or higher or "Pass".					SLP 246 - 2.5 UNITS CLINICAL EXPERIENCE II Transferable to CSU Prerequisite: Completion of SLP 235 and SLP 241 with a grade of "C" or better, or equivalent.				
22333	12:30-2:45PM	TTh	Cabuto,F	LA212	29562	5:00-5:50PM	M	McDonald,S McDonald,S	SL106
SPAN 223 - 3.0 UNITS SPANISH FOR HEALTH AND MEDICAL CAREERS Transferable to CSU					SLP 246 - 2.5 UNITS CLINICAL EXPERIENCE II Transferable to CSU Prerequisite: Completion of SLP 235 and SLP 241 with a grade of "C" or better, or equivalent.				
23433	9:00-11:50AM	F	Bedolla,J	LA210	25169	5:00-5:50PM	T	McDonald,S McDonald,S	SL106
SPAN 245 - 3.0 UNITS INTRODUCTION TO CHICANO/MEXICAN AMERICAN CULTURE Transferable to UC, CSU					SLP 246 - 2.5 UNITS CLINICAL EXPERIENCE II Transferable to CSU Prerequisite: Completion of SLP 235 and SLP 241 with a grade of "C" or better, or equivalent.				
20737	8:00-10:45AM	T	STAFF	LA212	SLP 246 - 2.5 UNITS CLINICAL EXPERIENCE II Transferable to CSU Prerequisite: Completion of SLP 235 and SLP 241 with a grade of "C" or better, or equivalent.				
21029	3.0 HRS ARR	(OL)	STAFF	ONLINE	SLP 246 - 2.5 UNITS CLINICAL EXPERIENCE II Transferable to CSU Prerequisite: Completion of SLP 235 and SLP 241 with a grade of "C" or better, or equivalent.				
INSTRUCTOR WILL CONTACT ENROLLED STUDENTS BEFORE THE FIRST DAY OF CLASS.					SLP 246 - 2.5 UNITS CLINICAL EXPERIENCE II Transferable to CSU Prerequisite: Completion of SLP 235 and SLP 241 with a grade of "C" or better, or equivalent.				
SPAN 260 - 3.0 UNITS FRIDA KAHLO AND MEXICAN MURALISTS Transferable to UC, CSU Recommendation: ENGL 52 or ENGL 72 or ESL 152 or equivalent with a grade of "C" or higher or "Pass" or completion of the English placement process with a score eligible for ENGL 100.					SLP 246 - 2.5 UNITS CLINICAL EXPERIENCE II Transferable to CSU Prerequisite: Completion of SLP 235 and SLP 241 with a grade of "C" or better, or equivalent.				
30085	8:00-10:45AM	Th	Cabuto,F	LA212	SLP 246 - 2.5 UNITS CLINICAL EXPERIENCE II Transferable to CSU Prerequisite: Completion of SLP 235 and SLP 241 with a grade of "C" or better, or equivalent.				

SPEECH AND LANGUAGE PATHOLOGY

The Speech-Language Pathology Assistant curriculum prepares graduates to work under the supervision of a licensed Speech-Language Pathologist, who evaluates, diagnoses, and treats individuals with various communication disorders.

SLP 101 - 3.0 UNITS INTRODUCTION TO COMMUNICATION DISORDERS Transferable to CSU Recommendation: ENGL 52, or ENGL 72, or ESL 152, or equivalent with a grade of "C" or higher or "Pass", OR completion of the assessment/placement process with eligibility for ENGL 100.				
29558	6:00-9:10PM	MW	McDonald,S	SL106
Class# 29558 meets 01/13/2020-03/11/2020				
SLP 105 - 3.0 UNITS SPEECH AND LANGUAGE DEVELOPMENT IN CHILDREN Transferable to CSU Recommendation: ENGL 52, or ENGL 72, or ESL 152, or equivalent with a grade of "C" or higher or "Pass", or completion of the assessment/placement process with eligibility for ENGL 100.				
29559	6.0 HRS ARR	(OL)	McDonald,S	ONLINE
Class# 29559 meets 01/13/2020-03/13/2020				
SLP 230 - 1.5 UNITS INTRODUCTION TO AUGMENTATIVE AND ALTERNATIVE COMMUNICATION Transferable to CSU Prerequisite: SLP 125 with a grade of "C" or higher or "Pass."				
21019	6:00-7:30PM 7:30-7:45PM	T T	Buchheit,A Buchheit,A	SL106 SL106

THEATRE ARTS

TH 101 - 3.0 UNITS INTRODUCTION TO THE THEATRE Transferable to UC, CSU (CAN DRAM 18)				
20756	3.0 HRS ARR	(OL)	Wahlquist,L	ONLINE
20757	12:30-1:50PM	MW	STAFF	BC 47
20758	11:00-12:20PM	TTh	Prell,J	FA133
21783	9:00-10:30AM	TTh	Prell,J	FA133
25278	11:00-12:20PM	MW	Sneed,H	BC 47
26681	9:30-10:50AM	MW	Hartl,F	CB103
28214	6.0 HRS ARR	(OL)	Reiter,B	ONLINE
Class# 28214 meets 01/13/2020-03/13/2020				
28736	6.0 HRS ARR	(OL)	STAFF	ONLINE
Class# 28736 meets 01/13/2020-03/13/2020				
28215	6.0 HRS ARR	(OL)	Reiter,B	ONLINE
Class# 28215 meets 03/23/2020-05/22/2020				
28740	6.0 HRS ARR	(OL)	Wahlquist,L	ONLINE
Class# 28740 meets 03/23/2020-05/22/2020				
30284	6:00-9:20PM	Th	STAFF	BC47
Class# 30284 meets 02/06/2020-05/21/2020				
TH 110 - 3.5 UNITS FUNDAMENTALS OF ACTING Transferable to UC, CSU (CAN DRAM 8)				
28737	3:00-4:45PM 5:00-6:10PM	TTh TTh	Reiter,B Reiter,B	FA140 FA140
Class# 28737 meets 01/13/2020-04/28/2020				
TH 111 - 3.5 UNITS INTERMEDIATE ACTING TO CHARACTERIZATION Transferable to UC, CSU (CAN DRAM 22) Prerequisite: TH 110 or equivalent with a grade of "C" or higher or "Pass".				
23595	12:30-2:00PM 2:00-2:50PM	MW MW	Sneed,H Sneed,H	BC 31 BC 31
TH 114 - 2.0 UNITS VOICE FOR ACTING Transferable to UC, CSU (CAN DRAM 6)				
27212	3:30-4:35PM 4:45-6:50PM	W W	Reiter,B Reiter,B	BC 31 BC 31
Class# 27212 meets 01/13/2020-04/28/2020				
TH 123 - 3.0 UNITS STAGE MAKE-UP Transferable to UC, CSU (CAN DRAM 14)				
27069	12:30-1:30PM 1:30-2:50PM	TTh TTh	Watanabe-Lonsbury,S Watanabe-Lonsbury,S	SB 22 BC 20

Students not in attendance or late for the first class meeting are subject to drop.

Class#	Time	Day	Instructor	Room	Class#	Time	Day	Instructor	Room
29155	12:20-1:20PM 1:20-2:40PM	TTh TTh	Stahl,C Stahl,C	SOHS* SOHS*	TH 146 - 2.0 UNITS MUSICAL THEATRE PRODUCTION FOR CHORUS Transferable to UC, CSU				
This class is, offered through the College and Career Access Pathways agreement, and is, targeted for Somerset High School students.					25727	7:00-8:15PM 8:15-9:15PM	WTh WTh	STAFF STAFF	BC 31 BC 31
TH 126A - 3.0 UNITS WIGS AND HAIR FOR THEATRE I Transferable to CSU					TH 147 - 3.0 UNITS MUSICAL THEATRE PRODUCTION FOR LEADING ROLES Transferable to UC, CSU				
23890	7:00-8:00PM 8:00-9:20PM	MW MW	Stahl,C Stahl,C	BC 22 BC 22	25729	7:00-8:15PM 8:15-9:15PM	WTh WTh	STAFF STAFF	BC 31 BC 31
TH 126B - 3.0 UNITS WIGS AND HAIR FOR THEATRE II Transferable to CSU Prerequisite: TH 126A or equivalent with a grade of Pass or "C" or higher.					TH 150 - 3.0 UNITS APPRECIATION AND HISTORY OF THE MOTION PICTURE Transferable to UC, CSU				
23905	8:00-9:20PM 7:00-8:00PM	MW MW	Stahl,C Stahl,C	BC 22 BC 22	23019	9:00-11:50AM	F	Breit,C	BC 47
TH 130 - 1.0 UNIT REHEARSAL AND PERFORMANCE FOR THE MINOR ROLE Transferable to UC, CSU					21034	12:30-3:20PM	T	Piotrowski,C	FA133
21171	7:00-7:35PM	F	STAFF	BC 31	23666	7:00-9:50PM	F	Campolo,R (HYBRID)	FA133
+ 5.0 HRS ARR STAFF BC 31 Class# 21171 meets 01/17/2020-03/13/2020					20763	3.6 HRS ARR (OL)		Campolo,R	ONLINE
21106	7:00-7:35PM	F	STAFF	BC 31	Class# 20763 meets 02/03/2020-05/22/2020				
+ 5.0 HRS ARR STAFF BC 31 Class# 21106 meets 03/27/2020-05/22/2020					21627	3.6 HRS ARR (OL)		Campolo,R	ONLINE
TH 131 - 2.0 UNITS REHEARSAL AND PERFORMANCE FOR THE SUPPORTING ROLE Transferable to UC, CSU					Class# 21627 meets 02/03/2020-05/22/2020				
21172	7:00-8:10PM	F	STAFF	BC 31	TH 151 - 3.0 UNITS MOTION PICTURES, RADIO AND TELEVISION Transferable to CSU				
+ 8.0 HRS ARR STAFF BC 31 Class# 21172 meets 01/17/2020-03/13/2020					20764	8:00-9:20AM	MW	Breit,C	BC 47
21107	7:00-8:10PM	F	STAFF	BC 31	22881	9:30-10:50AM	TTh	Piotrowski,C	BC 47
+ 8.0 HRS ARR STAFF BC 31 Class# 21107 meets 03/27/2020-05/22/2020					21784	2:00-5:20PM	W	Campolo,R	BC 47
TH 132 - 3.0 UNITS REHEARSAL AND PERFORMANCE FOR THE LEADING ROLES Transferable to UC, CSU (CAN DRAM 16)					Class# 21784 meets 02/05/2020-05/20/2020				
21173	7:00-8:10PM	F	STAFF	BC 31	TH 221 - 3.0 UNITS COSTUMING FOR THE STAGE Transferable to UC, CSU				
+14.0 HRS ARR STAFF BC 31 Class# 21173 meets 01/17/2020-03/13/2020					26784	10:00-11:00AM	MW	Watanabe-Lonsbury,S	SB 22
21108	7:00-8:10PM	F	STAFF	BC 31	11:00-12:20PM MW Watanabe-Lonsbury,S BC 10				
+14.0 HRS ARR STAFF BC 31 Class# 21108 meets 03/27/2020-05/22/2020					TH 221A - 3.0 UNITS ADVANCED COSTUMING FOR THE STAGE Transferable to UC, CSU				
TH 133 - 1.0 UNIT STAGE CREW ACTIVITY Transferable to UC, CSU					Prerequisite: TH 221 or equivalent with a grade of "C" or higher or "Pass".				
27091	3:00-4:00PM	T	Watanabe-Lonsbury,S	BC 20	26787	10:00-11:00AM	MW	Watanabe-Lonsbury,S	SB 22
+ 5.0 HRS ARR Watanabe-Lonsbury,S BC 20 Class# 27091 meets 01/14/2020-03/10/2020					11:00-12:20PM MW Watanabe-Lonsbury,S BC 10				
22328	10:00-11:00AM	F	Lock,B	BC 20	WELDING				
11:00-2:00PM F Walton,E BC 20 Class# 22328 meets 01/17/2020-03/13/2020					WELD 49 - 4.0 UNITS WELDING SHOP MATH Not Transferable Recommendation: WELD 100 or equivalent with a grade of "C" or higher or "Pass" or WELD 120 or equivalent with a grade of "C" or higher or "Pass" or WELD 130 or equivalent with a grade of "C" or higher or "Pass". Please read the technical standards relevant to this department at https://www.cerritos.edu/technology/standards.htm .				
21787	10:00-12:00PM	F	Lock,B	BC 20	23115	6:00-9:50PM	T	Tait,M	ME 2
12:00-2:00PM F Ward,D BC 20 Class# 21787 meets 03/27/2020-05/22/2020					28102	7:00-10:50AM	Th	Nunez,J	ME 2
TH 134 - 2.0 UNITS TECHNICAL PRODUCTION Transferable to UC, CSU					WELD 52 - 4.0 UNITS PIPE WELDING FUNDAMENTALS Not Transferable Prerequisite: WELD 210L or equivalent with a grade of "C" or higher or "Pass". Recommendation: Current Los Angeles City or AWS certification for structural steel.				
22330	10:00-11:00AM	F	Lock,B	BC 20	28106	6:00-7:00PM 7:00-9:50PM	TTh TTh	Allen Jr.,A Allen Jr.,A	ME 13 ME 13
11:00-2:00PM F Walton,E BC 20 Class# 22330 meets 01/17/2020-03/13/2020					WELD 53 - 2.0 UNITS PIPE LAYOUT Not Transferable Prerequisite: WELD 120 or equivalent with a grade of "C" or higher or "Pass" or appropriate work experience.				
21789	10:00-12:00PM	F	Lock,B	BC 20	28108	5:00-6:00PM 6:00-8:50PM	F F	Allen Jr.,A Allen Jr.,A	ME 13 ME 13
12:00-2:00PM F Ward,D BC 20 Class# 21789 meets 03/27/2020-05/22/2020					WELD 54L - 2.0 UNITS ADVANCED PIPE WELDING Not Transferable Prerequisite: WELD 52 or equivalent with a grade of "C" or higher or "Pass".				
TH 136 - 2.0 UNITS TOURING THEATRE PRODUCTION FOR SUPPORTING ROLES Transferable to CSU					28110	8:00-2:25PM	Sat	Huerta,V	ME 13
27451	9:00-12:00PM	F	Hartl,F	BC 31	Class# 28110 meets 01/18/2020-05/16/2020				
Class# 27451 meets 03/27/2020-05/22/2020					WELDING				
27452	+ 3.0 HRS ARR		Hartl,F	BC 31	WELD 49 - 4.0 UNITS WELDING SHOP MATH Not Transferable Recommendation: WELD 100 or equivalent with a grade of "C" or higher or "Pass" or WELD 120 or equivalent with a grade of "C" or higher or "Pass" or WELD 130 or equivalent with a grade of "C" or higher or "Pass". Please read the technical standards relevant to this department at https://www.cerritos.edu/technology/standards.htm .				
Class# 27452 meets 03/27/2020-05/22/2020					WELD 52 - 4.0 UNITS PIPE WELDING FUNDAMENTALS Not Transferable Prerequisite: WELD 210L or equivalent with a grade of "C" or higher or "Pass". Recommendation: Current Los Angeles City or AWS certification for structural steel.				
TH 137 - 2.0 UNITS TOURING THEATRE PRODUCTION FOR LEADING ROLES Transferable to CSU					WELD 53 - 2.0 UNITS PIPE LAYOUT Not Transferable Prerequisite: WELD 120 or equivalent with a grade of "C" or higher or "Pass" or appropriate work experience.				
27449	9:00-12:00PM	F	Hartl,F	BC 31	28106	6:00-7:00PM 7:00-9:50PM	TTh TTh	Allen Jr.,A Allen Jr.,A	ME 13 ME 13
+ 5.0 HRS ARR Hartl,F BC 31 Class# 27449 meets 03/27/2020-05/22/2020					WELD 54L - 2.0 UNITS ADVANCED PIPE WELDING Not Transferable Prerequisite: WELD 52 or equivalent with a grade of "C" or higher or "Pass".				

Students not in attendance or late for the first class meeting are subject to drop.

Class#	Time	Day	Instructor	Room	Class#	Time	Day	Instructor	Room
WELD 56L - 2.0 UNITS ARC WELDING 6" PIPE CERTIFICATION LABORATORY Not Transferable Prerequisite: WELD 54L or equivalent with a grade of "C" or higher or "Pass". 28190 8:00-2:25PM Sat Huerta,V ME 13 Class# 28190 meets 01/18/2020-05/16/2020					WELD 214L - 2.0 UNITS FLUX CORED ARC WELDING (FCAW) CERTIFICATION LABORATORY Transferable to CSU Prerequisite: WELD 210L or equivalent with a grade of "C" or higher or "Pass". B23132 7:00-9:50PM MW Nunez,J ME 13 23683 4:00-6:50PM MW Nunez,J ME 13 28762 8:00-11:00AM MW Allen Jr.,A ME 13				
WELD 58L - 2.0 UNITS ARC WELDING 2" PIPE CERTIFICATION LABORATORY Not Transferable Prerequisite: WELD 56L or equivalent with a grade of "C" or higher or "Pass". 28191 8:00-2:25PM Sat Huerta,V ME 13 Class# 28191 meets 01/18/2020-05/16/2020					WELD 240L - 2.0 UNITS INTERMEDIATE GAS TUNGSTEN ARC WELDING LABORATORY Transferable to CSU Prerequisite: WELD 130 or equivalent with a grade of "C" or higher or "Pass". 21040 5:30-8:20PM TTh Perkins,D ME 13 23548 7:00-2:00PM Sat Perkins,D ME 13 Class# 23548 meets 01/18/2020-05/16/2020				
WELD 59 - 4.0 UNITS BLUEPRINT READING FOR THE WELDING TRADES Not Transferable Recommendation: WELD 100 or equivalent with a grade of "C" or higher or "Pass" or WELD 120 or equivalent with a grade of "C" or higher or "Pass" or WELD 130 or equivalent with a grade of "C" or higher or "Pass". 23123 2:00-5:50PM T Tait,M ME 2 28103 7:00-10:50AM T Nunez,J ME 2					WELD 250L - 2.0 UNITS ADVANCED GAS TUNGSTEN ARC WELDING LAB Transferable to CSU Prerequisite: WELD 240L or equivalent with a grade of "C" or higher or "Pass". 21041 5:30-8:20PM TTh Perkins,D ME 13 23549 7:00-2:00PM Sat Perkins,D ME 13 Class# 23549 meets 01/18/2020-05/16/2020				
WELD 100 - 2.5 UNITS WELDING FUNDAMENTALS Transferable to CSU 22337 8:00-10:00AM F Nunez,J ME 13 10:00-11:50AM F Nunez,J ME 13 28616 10:30-12:45PM Sat Ty,H ME 13 12:45-2:15PM Sat Ty,H ME 13 Class# 28616 meets 01/18/2020-05/16/2020					WELD 260L - 2.0 UNITS GAS TUNGSTEN ARC WELDING (GTAW) AEROSPACE CERTIFICATION LAB Transferable to CSU Prerequisite: WELD 250L or equivalent with a grade of "C" or higher or "Pass". 23134 5:30-8:20PM TTh Perkins,D ME 13 23550 7:00-2:00PM Sat Perkins,D ME 13 Class# 23550 meets 01/18/2020-05/16/2020				
WELD 120 - 5.0 UNITS BEGINNING ARC WELDING Transferable to CSU Recommendation: WELD 100 with a grade of "C" or higher or "Pass" or concurrent enrollment or appropriate work experience. 20767 7:00-9:00AM MW Foral,J ME 13 9:00-10:50AM MW Foral,J ME 13 21036 6:00-8:00PM MW Figueroa,M ME 3C 8:00-9:50PM MW Figueroa,M ME 3C 26206 7:00-9:15AM Sat Stainbrook,F ME 13 5:00-7:15PM F Stainbrook,F ME 13 9:15-11:20AM Sat Stainbrook,F ME 13 7:15-9:20PM F Stainbrook,F ME 13					WOMEN'S AND GENDER STUDIES				
WELD 130 - 5.0 UNITS GAS TUNGSTEN ARC WELDING FUNDAMENTALS Transferable to CSU Recommendation: WELD 100 or WELD 120 or equivalent with a grade of "C" or higher or "Pass" or concurrent enrollment or appropriate work experience. 21037 6:00-8:00PM MW Tait,M ME 2G 8:00-9:50PM MW Tait,M ME 13 27058 7:00-9:00AM TTh Foral,J ME 2G 9:00-10:50AM TTh Foral,J ME 13					WGS 101 - 3.0 UNITS ISSUES FOR WOMEN IN AMERICAN SOCIETY Transferable to UC, CSU Prerequisite: Completion of ENGL 52, or ENGL 72, or ESL 152 or equivalent with a grade of "C" or higher, or "Pass," or completion of the English Placement Process with eligibility for ENGL 100. 22876 12:30-1:45PM MW Fagundes,M SS307 21045 5:00-6:30PM MW STAFF BE105 Class# 21045 meets 02/03/2020-05/20/2020				
WELD 200 - 4.0 UNITS INTERMEDIATE ARC WELDING Transferable to CSU Prerequisite: WELD 120 or equivalent with a grade of "C" or higher or "Pass" or appropriate work experience. 21038 6:00-7:00PM TTh Arvizo,D ME 13 7:00-9:50PM TTh Arvizo,D ME 13 28104 7:00-8:00AM TTh Allen Jr.,A ME 13 8:00-10:50AM TTh Allen Jr.,A ME 13					WGS 102 - 3.0 UNITS WOMEN AND RELIGION Transferable to UC, CSU Prerequisite: Completion of ENGL 52, or ENGL 72, or ESL 152 or equivalent with a grade of "C" or higher, or "Pass," or completion of the English Placement Process with eligibility for ENGL 100. 22442 2:00-3:15PM TTh STAFF BE106 28954 7:00-9:50PM T STAFF SS138				
WELD 210L - 2.0 UNITS ADVANCED ARC WELDING LABORATORY Transferable to CSU Prerequisite: WELD 200 or equivalent with a grade of "C" or higher or "Pass". 20771 7:00-9:50PM MW Nunez,J ME 13 21039 4:00-6:50PM MW Nunez,J ME 13 28760 8:00-11:00AM MW Allen Jr.,A ME 13					WGS 103 - 3.0 UNITS WOMEN, THEIR BODIES AND HEALTH Transferable to UC, CSU 21856 9:30-10:45AM MW STAFF(Women's Studies) SS138 23707 6:30-9:20PM TTh STAFF (Women's Studies) SS307 Class# 23707 meets 03/24/2020-05/21/2020				
WELD 212L - 2.0 UNITS SHIELDED METAL ARC WELDING (SMAW) CERTIFICATION LABORATORY Transferable to CSU Prerequisite: WELD 210L or equivalent with a grade of "C" or higher or "Pass". 23127 7:00-9:50PM MW Nunez,J ME 13 23129 4:00-6:50PM MW Nunez,J ME 13 28761 8:00-11:00AM MW Allen Jr.,A ME 13					WGS 104 - 3.0 UNITS COMMUNITY ORGANIZING AND ACTIVISM Transferable to UC, CSU Recommendation: WGS 101 with a grade of "C" or higher or "Pass" and completion of ENGL 52, or ENGL 72, or ESL 152 or equivalent with a grade of "C" or higher, or "Pass," or completion of the English Placement Process with eligibility for ENGL 100. 29711 2:00-3:15PM TTh STAFF SS140				
					WGS 108 - 3.0 UNITS WOMEN IN SPORTS Transferable to UC, CSU 25696 3.0 HRS ARR Kozlowski,T (Women's Studies) ONLINE 28137 6.0 HRS ARR (OL) Kozlowski,T ONLINE Class# 28137 meets 03/23/2020-05/22/2020				
					WGS 109 - 3.0 UNITS PHILOSOPHY OF THE BODY, FEMINISM, AND GENDER Transferable to UC, CSU Prerequisite: Completion of ENGL 52, or ENGL 72, or ESL 152 or equivalent with a grade of "C" or higher or "Pass", or completion of the English Placement Process with eligibility for ENGL 100. 27312 2:00-3:15PM TTh Mayock,M (Women's Studies) SS307				

Students not in attendance or late for the first class meeting are subject to drop.

Class#	Time	Day	Instructor	Room	Class#	Time	Day	Instructor	Room
WGS 115 - 3.0 UNITS GENDER, COMMUNICATION, AND THE DIGITAL REVOLUTION Transferable to UC, CSU Prerequisite: Completion of at least one of these courses with a grade of "C" or higher or "Pass" or an equivalent course: SPCH 60, ENGL 72, ESL 152, READ 54, READ 97 or completion of the English or Reading placement/assessment process with eligibility for ENGL 100.					WMT 102 - 4.0 UNITS INTRODUCTION TO SOLID WOOD CASEGOODS Transferable to CSU Prerequisite: Completion of WMT 101 with a grade of "C" or higher or "Pass."				
29713	9:30-11:00AM	TTh	Rosenfeld,K	MP209	21090	7:00-8:15AM	TTh	Fortner,A	WD 14
	Class# 29713 meets 02/04/2020-05/21/2020					8:15-10:50AM	TTh	Fortner,A	WD 14
29712	6.0 HRS ARR	(OL)	Rosenfeld,K	ONLINE	WMT 102L - 2.5 UNITS CASEGOOD MANUFACTURING LAB				
	Class# 29712 meets 01/13/2020-03/13/2020				Transferable to CSU				
28777	6.0 HRS ARR	(OL)	Rosenfeld,K	ONLINE	24253	7:00-10:50AM	TTh	Fortner,A	WD 14
	Class# 28777 meets 03/23/2020-05/22/2020				Prerequisite: WMT 102 or equivalent with a grade of "C" or higher or "Pass".				
WGS 202 - 3.0 UNITS GENDER AND SOCIETY Transferable to UC, CSU					WMT 103 - 4.0 UNITS INTRODUCTION TO TABLES Transferable to CSU Prerequisite: Completion of WMT 101 with a grade of "C" or higher or "Pass."				
29065	7:00-9:50PM	W	STAFF	SS138	25654	6:00-7:15PM	TTh	Thornbury,R	WD 14
28122	2:00-3:30PM	MW	Holzgang,A	SS138		7:15-9:50PM	TTh	Thornbury,R	WD 14
	Class# 28122 meets 02/03/2020-05/20/2020				WMT 103L - 2.5 UNITS TABLE MANUFACTURING LAB				
27065	12:30-2:00PM	TTh	Holzgang,A	SS138	Transferable to CSU				
	Class# 27065 meets 02/04/2020-05/21/2020				Prerequisite: WMT 103 or equivalent with a grade of "C" or higher or "Pass"				
WGS 205 - 3.0 UNITS THE ANTHROPOLOGY OF SEXUALITY AND GENDER Transferable to UC, CSU					WMT 107 - 3.0 UNITS WOOD FINISHING Transferable to CSU				
27066	12:30-1:45PM	MW	STAFF	(Women's Studies) SS139	21091	8:00-10:15AM	Sat	Miller,B	WD 13
						10:15-2:25PM	Sat	Miller,B	WD 13
					Class# 21091 meets 01/18/2020-05/16/2020				
WGS 208 - 3.0 UNITS LEADERSHIP FOR WOMEN IN BUSINESS Transferable to CSU					WMT 108 - 2.5 UNITS WOOD CARVING FOR FURNITURE Transferable to CSU Recommendation: Basic math skills, spatial skills, and eye/hand coordination are recommended.				
24196	6.0 HRS ARR		Livingston,B (Women's Studies)	ONLINE	29610	8:00-10:00AM	T	Trimble,W	WD 13
	Class# 24196 meets 03/23/2020-05/22/2020				29611	10:00-11:50AM	T	Trimble,W	WD 13
27063	6.0 HRS ARR	(OL)	Livingston,B	ONLINE	WMT 111L - 1.0 UNIT INTRODUCTION TO WOODWORKING LAB				
	Class# 27063 meets 01/13/2020-03/13/2020				Transferable to CSU				
29030	6.0 HRS ARR	(OL)	Livingston,B	ONLINE	Prerequisite: WMT 101 or equivalent with a grade of "C" or higher or "Pass."				
	Class# 29030 meets 03/23/2020-05/22/2020				27932	6:00-8:50PM	M	Stammerjohn,C	WD 14
	For class information refer to Canvas or contact your instructor.				28242	7:00-9:50PM	F	Sanchez,C	WD 14
					28658	12:45-3:35PM	F	STAFF	WD 14
WGS 250 - 3.0 UNITS FOUNDATIONS OF FEMINIST, GENDER, AND QUEER THEORIES Transferable to UC, CSU Prerequisite: Completion of ENGL 52, ENGL 72, or ESL 152 or equivalent with a grade of "C" or higher, or "Pass," or completion of the English Placement Process with eligibility for ENGL 100.					WMT 118 - 2.0 UNITS INTRODUCTION TO WOODTURNING Transferable to CSU Recommendation: Basic math skills, spatial skills, and eye/hand coordination are recommended.				
28778	5:30-7:00PM	TTh	Youssef,M	SS309	27824	6:00-7:00PM	Th	Hernandez,B	WD 12
	Class# 28778 meets 02/04/2020-05/21/2020					7:00-9:50PM	Th	Hernandez,B	WD 12
WGS 298 - 1.0 UNIT DIRECTED STUDIES Transferable to CSU					WMT 119L - 1.0 UNIT INTRODUCTION TO WOODTURNING LAB Transferable to CSU Prerequisite: WMT 118 or equivalent with a grade of "C" or higher or "Pass."				
28297	3.6 HRS ARR		STAFF		27826	6:00-9:50PM	Th	Hernandez,B	WD 12
	Class# 28297 meets 02/03/2020-05/22/2020				WMT 144 - 2.0 UNITS JIGS AND FIXTURES				
WGS 299 - 2.0 UNITS DIRECTED STUDIES Transferable to CSU					Transferable to CSU				
28298	7.2 HRS ARR		STAFF		Prerequisite: Completion of WMT 102 or WMT 103 or WMT 151 or equivalent with a grade of "C" or higher or "Pass."				
	Class# 28298 meets 02/03/2020-05/22/2020				28624	6:00-7:00PM	M	Stammerjohn,C	WD 14
						7:00-9:50PM	M	Stammerjohn,C	WD 14
WOODWORKING MANUFACTURING TECHNOLOGY									
WMT 101 - 3.0 UNITS INTRODUCTION TO WOODWORKING Transferable to CSU Recommendation: Basic math skills, spatial skills, and eye/hand coordination are recommended. Please read the technical standards relevant to this department at https://www.cerritos.edu/technology/standards.htm .					WMT 151 - 4.0 UNITS INTRODUCTION TO FACEFRAME CABINETMAKING Transferable to CSU				
28240	5:30-8:00PM	F	Sanchez,C	WD 14	27933	8:00-9:15AM	MW	Fortner,A	WD 15
	8:00-9:45PM	F	Sanchez,C	WD 14		9:15-11:50AM	MW	Fortner,A	WD 15
28618	11:30-2:00PM	F	STAFF	WD 14	29614	8:00-10:48AM	Sat	Wood,J	WD 15
	2:00-3:45PM	F	STAFF	WD 14		10:48-4:50PM	Sat	Wood,J	WD 15
24251	8:00-10:48AM	Sat	Sanchez,C	WD 14	Class# 29614 meets 01/18/2020-05/16/2020				
	10:48-12:50PM	Sat	Sanchez,C	WD 14	WMT 153 - 4.0 UNITS 32MM SYSTEM OF CABINETMAKING				
	Class# 24251 meets 01/18/2020-05/16/2020				Transferable to CSU				
					Prerequisite: Completion of WMT 151 or equivalent with a grade of "C" or higher or "Pass."				
28626	6:00-7:15PM	MW	Krause,P	WD 15		7:15-9:50PM	MW	Krause,P	WD 15

Students not in attendance or late for the first class meeting are subject to drop.

Class#	Time	Day	Instructor	Room	Class#	Time	Day	Instructor	Room
--------	------	-----	------------	------	--------	------	-----	------------	------

WMT 181 - 3.0 UNITS INTRODUCTION TO CABINET VISION

Transferable to CSU

28628	6:00-9:00PM	M	Koford,B	WD 1
	9:00-9:50PM	M	Koford,B	WD 1

WMT 201 - 4.0 UNITS WOODWORKING WITH HAND TOOLS

Transferable to CSU

30004	1:00-2:15PM	TTh	Stammerjohn,C	WD 13
	2:15-4:50PM	TTh	Stammerjohn,C	WD 13

WMT 212 - 4.0 UNITS ROUTERS AND ROUTER TABLES

Transferable to CSU

Prerequisite: WMT 102 or WMT 103 or WMT 151 or equivalent with a grade of "C" or higher or "Pass."

29618	1:00-2:15PM	MW	Stammerjohn,C	WD 13
	2:15-4:50PM	MW	Stammerjohn,C	WD 13

WMT 222 - 2.0 UNITS ADVANCED HANDTOOLS - JOINERY

Transferable to CSU

Prerequisite: Completion of WMT 201 or equivalent with a grade of "C" or higher, or "Pass" and completion of WMT 101 or WMT 151 or equivalent with a grade of "C" or higher or "Pass."

29620	8:00-9:00AM	W	Stammerjohn,C	WD 13
	9:00-11:50AM	W	Stammerjohn,C	WD 13

WMT 229L - 2.5 UNITS COMPREHENSIVE WOODWORKING MANUFACTURING SPECIALTY LAB

Transferable to CSU

Prerequisite: WMT 102 or WMT 103 or WMT 151 or equivalent with a grade of "C" or higher or "Pass."

28764	6:00-9:50PM	MW	Krause,P	WD 15
28765	1:00-4:50PM	MW	Stammerjohn,C	WD 13

WMT 233 - 4.0 UNITS MORRIS CHAIR

Transferable to CSU

Prerequisite: WMT 102 and WMT 103 or equivalent with a grade of "C" or higher or "Pass."

29622	1:00-2:15PM	MW	Fortner,A	WD 14
	2:15-4:50PM	MW	Fortner,A	WD 14

WMT 249L - 2.5 UNITS FURNITURE MANUFACTURING SPECIALTY

Transferable to CSU

Prerequisite: WMT 102 or WMT 103 or equivalent with a grade of "C" or higher or "Pass".

28638	1:00-4:50PM	TTh	Stammerjohn,C	WD 14
29624	1:00-4:50PM	MW	Fortner,A	WD 14

WMT 269L - 2.5 UNITS CABINETMAKING MANUFACTURING SPECIALTY LAB

Transferable to CSU

Prerequisite: WMT 151 or equivalent with a grade of "C" or higher or "Pass."

26223	8:00-11:50AM	MW	Fortner,A	WD 14
29625	8:00-4:50PM	Sat	Wood,J	WD 15

Class# 29625 meets 01/18/2020-05/16/2020

WMT 281 - 2.5 UNITS INTERMEDIATE CABINET VISION

Transferable to CSU

Prerequisite: WMT 181 or equivalent with a grade of "C" or higher or "Pass."

29626	6:00-8:00PM	W	Koford,B	WD 1
	8:00-9:50PM	W	Koford,B	WD 1

WMT 282 - 4.0 UNITS INTERMEDIATE ALPHACAM AND THE CNC ROUTER

Transferable to CSU

Prerequisite: WMT 182 with a grade of "C" or higher or "Pass."

29628	1:00-2:15PM	TTh	Foat,R	WD 1
	2:15-4:50PM	TTh	Foat,R	WD 1

WMT 282L - 2.5 UNITS INTERMEDIATE CNC WOODWORKING LAB

Transferable to CSU

Prerequisite: WMT 282 with a grade of "C" or higher or "Pass."

29630	1:00-4:50PM	TTh	Foat,R	WD 1
-------	-------------	-----	--------	------

WMT 291 - 4.0 UNITS PRODUCTION CABINETMAKING

Transferable to CSU

Prerequisite: WMT 151 and one of the following: WMT 102, WMT 103, WMT 153, WMT 155, WMT 181, or WMT 250 or equivalent with a grade of "C" or higher or "Pass" or appropriate work experience.

29631	6:00-7:15PM	TTh	Foat,R	WD 13
	7:15-9:50PM	TTh	Foat,R	WD 13

ZOOLOGY

ZOOL 120 - 4.0 UNITS INTRODUCTION TO ANIMAL BIOLOGY

Transferable to UC, CSU

Prerequisite: ENGL 52 or ENGL 72 or ESL 152 or equivalent with a grade of "C" or higher or "Pass" or completion of the English placement process with a score eligible for ENGL 100.

21046	12:30-1:20PM	TTh	Henderson,S	S 127
	2:00-4:50PM	TTh	Henderson,S	S 127

SHORT TERM CLASSES

Class#	Course	Description	Class#	Course	Description
1st SIX WEEKS: 01/13/2020-002/21/2020			29943	COMM 115	Gender,Comm,&DigitalRevolution
29567	COUN 101B	Educational Planning	29957	COMM 130	Public Speaking
27072	HO 53	Electrocardiography	22344	COS 53	Adv Cosmet Manipulation
1st NINE WEEKS: 01/13/2020-03/13/2020			22288	COS 60A	Intro Cosmetology I
28648	AB 65	Mix and Adjusting Color	22292	COS 61A	Intermed Cosmetology I
28083	ACCT 61	Turbo Tax Accounting	22296	COS 62A	Advanced Cosmetology I
29565	ACLR 87	Using Scan-Read Tech in UDL	29133	COS 98	Directed Studies
28744	ACLR 101	Increasing YourAccessPotential	26803	COS 99	Directed Studies
26392	ANTH 115	Physical Anthropology	29996	COUN 101C	Navigating the Transfer Proces
28787	ART 101	Art History I	23156	COUN 200	Success College and Career
28181	ART 108	Black Images in Popular Cultur	29568	COUN 200	Success College and Career
29715	ART 109	Gender and Sexuality In Art	22147	DANC 100	Dance Appreciation
29717	ART 125	Intro to Visual & Cultural Std	22148	DANC 100	Dance Appreciation
29002	ASL 215	Beg Interpreting & Ethics 1	28111	DANC 100	Dance Appreciation
29673	ASTR 102	Intro Astron Stars Univrse	28112	DANC 100	Dance Appreciation
28799	ATH 203LB	Basketball, Men,Off Season	27309	ECON 201	Principles of Macroeconomics
25126	ATH 204L	Basketball, Women	22587	ECON 201M	Principles of Macroeconomics
22379	AUTO 73	Auto Occupational Work Exp	27739	EDT 110	Intro To Ed Technology
21145	AUTO 73	Auto Occupational Work Exp	27744	EDT 133	Spreadsheets for Educators
21048	AUTO 151	Auto Alignment Brake/Susp	20369	ENGL 100	Freshman Composition
21049	AUTO 161	Automotive Electricity	29119	ENGL 100	Freshman Composition
21486	AUTO 181	Elec Engine Management Sys	28885	ENGL 100	Freshman Composition
27262	BA 100	Fundamentals of Business	22569	ENGL 100	Freshman Composition
27263	BA 100	Fundamentals of Business	27926	ENGT 117	Geometrical Tolerancing
22541	BA 101	International Business	26891	ESL 11	ESL Reading 1
21760	BA 104	Managing Cultural Diversity	27287	ESL 120	Prep For Col Writing-NonEngl
22364	BA 106	Human Resource Management	22062	FIN 51	Retirement Plan/Investing
22603	BA 106	Human Resource Management	28712	GEOG 102	Cultural Geography
27314	BA 106	Human Resource Management	21656	HED 100	Contemp Health Problems
23033	BA 107	Human Relations In Bus	21117	HED 100	Contemp Health Problems
23777	BA 107	Human Relations In Bus	30088	HED 101	Stress Management
26711	BA 107	Human Relations In Bus	30089	HED 101	Stress Management
26857	BA 107	Human Relations In Bus	28973	HED 202	Health Systems & Perspectives
28246	BA 108	Labor Management Relations	27078	HO 55	Phlebotomy Procedures
27264	BA 109	Human Resource Development	22393	HO 56	Medication Calculations
27004	BA 110	Advertising	21687	HIST 102	Political & Social Hist-U.S.
27424	BA 113	Legal Environment of Business	23309	HUM 100	The Art of Being Human
27425	BA 113	Legal Environment of Business	29718	HUM 107	Men & Masculinities:Constr Man
20253	BA 114	Marketing	28182	HUM 108	Black Images in Popular Cultur
23015	BA 114	Marketing	29716	HUM 109	Gender and Sexuality In Art
26677	BA 114	Marketing	30127	HUM 125	IntroVisual&Cultural Std
27733	BA 114	Marketing	25345	KIN 298	Directed Studies
20817	BA 115	Management-Business	28747	LIBR 100	Intro to Library Research
23479	BA 118	Retail Management	28749	LIBR 100	Intro to Library Research
28283	BA 118	Retail Management	30021	MATH 5	Math Learning Strategies
24205	BA 120	Mgmt-Act & Internal Contrl	22221	MATH 40	Prealgebra
26679	BA 120	Mgmt-Act & Internal Contrl	22261	MATH 40	Prealgebra
26722	BA 120	Mgmt-Act & Internal Contrl	22575	MATH 60	Elementary Algebra
27734	BA 121	Sales	22220	MATH 70	Plane Geometry
22265	BA 132	Computer Applications/Mgrs	27807	MATH 70	Plane Geometry
27012	BA 132	Computer Applications/Mgrs	20500	MATH 80	Intermediate Algebra
29692	BA 132	Computer Applications/Mgrs	25810	MATH 80	Intermediate Algebra
28095	BA 153	Small Business Management	26272	MATH 80	Intermediate Algebra
22864	BA 156	Motivational Skills/Mgrs	26812	MATH 80	Intermediate Algebra
25784	BA 156	Motivational Skills/Mgrs	21561	MATH 114	College Algebra
26728	BA 156	Motivational Skills/Mgrs	30010	MATH 140	Trigonometry
27736	BA 156	Motivational Skills/Mgrs	22461	MATH 170	Analytic Geom & Calc I
26730	BA 157	Principles of Public Relations	26961	MTT 62	Fixture Tooling
24206	BA 208	Leadership for Women in Bus	21898	NRSG 48T	Elective Nursing - Tutorial
21051	BCOT 62	Computer Keyboarding	21060	NRSG 210	Fundamentals of Nursing
21095	CA 101	Intro/Food Serv Safety-San	21061	NRSG 210	Fundamentals of Nursing
26379	CA 55	FundOfResponsibleAlcoholServ	21062	NRSG 210	Fundamentals of Nursing
23281	CDEC 133	Experiences/Math & Science	21063	NRSG 210	Fundamentals of Nursing
28678	CIS 101	Intro Computer Info Systems	22726	NRSG 210	Fundamentals of Nursing
24147	CIS 170A	Networking Fundamentals	21119	NRSG 211	Intr Theoretical Framework
25772	CIS 58A	PC Operating System A+ Cert	21511	NRSG 213B	Major Drugs and Nursing II
29937	COMM 100	Intro to Communication Studies	21066	NRSG 220	Medical-Surgical Nursing 3
29940	COMM 110	Intercultural Communication	21067	NRSG 220	Medical-Surgical Nursing 3
			21068	NRSG 220	Medical-Surgical Nursing 3
			21069	NRSG 220	Medical-Surgical Nursing 3
			21100	NRSG 220	Medical-Surgical Nursing 3
			21071	NRSG 230	Psychosocial-Community Nsg
			21072	NRSG 230	Psychosocial-Community Nsg
			21073	NRSG 230	Psychosocial-Community Nsg
			21074	NRSG 230	Psychosocial-Community Nsg

Attendance is mandatory (including wait listed students). Failure to appear will jeopardize your official enrollment.

SHORT TERM CLASSES

Class#	Course	Description	Class#	Course	Description
OPEN ENTRY/OPEN EXIT: 01/13/2020-05/22/2020					
29557	NRSG 230	Psychosocial-Community Nsg	29974	COMM 231	Forensics Activity 1
21077	NRSG 240	Medical-Surgical Nursing 5	29975	COMM 232	Forensics Activity 2
21078	NRSG 240	Medical-Surgical Nursing 5	29976	COMM 233	Forensics Activity 3
21079	NRSG 240	Medical-Surgical Nursing 5	25630	NRSG 57LA	Beginning Nursing Skills Lab
21102	NRSG 240	Medical-Surgical Nursing 5	25631	NRSG 57LB	Inter Nursing Skills Lab
28723	NRSG 240	Medical-Surgical Nursing 5	25632	NRSG 57LC	Adv/Inter Nursing Skills Lab
21899	NRSG 251	Bas Adult Physical Assessment	25633	NRSG 57LD	Advanced Nursing Skills Lab
28817	PEX 100A	Adapted Independent Exercise	2nd FIFTEEN WEEKS: 02/03/2020-05/22/2020		
29746	PEX 102	Adapted Cardiovascular Exer	23465	ACCT 100	Introduction to Accounting
23293	PHAR 55	Pharmacy Introduction	23053	ACCT 100	Introduction to Accounting
23294	PHAR 56	Pharmacy Skills Lab Intro	23467	ACCT 100	Introduction to Accounting
23298	PHAR 57	Pharmacy Operations I	26402	ACCT 100	Introduction to Accounting
20984	PHYS 201	Engineering Physics	22053	ACCT 100	Introduction to Accounting
27820	PMT 51	Composites Fabrication	24198	ACCT 101	Fundamentals of Accounting I
20680	PSYC 101	General Introductory Psyc	22047	ACCT 133	Spreadsheet Accounting I
20681	PSYC 101	General Introductory Psyc	22048	ACCT 133	Spreadsheet Accounting I
21554	PSYC 101	General Introductory Psyc	28085	ACCT 220	Accounting Ethics
28581	PSYC 101	General Introductory Psyc	29686	ACCT 251	Advanced Income Tax Accounting
29703	PSYC 261	Social Psychology	28768	ACCT 280	Advanced Accounting
29558	SLP 101	Intro Communication Disorders	24167	ANTH 100	Cultural Anthropology
29559	SLP 105	Speech & Lang Devlp in Childre	20199	ANTH 115	Physical Anthropology
28214	TH 101	Intro to the Theatre	22567	ART 156L	Ceramics Lab
28736	TH 101	Intro to the Theatre	21144	ART 156L	Ceramics Lab
21171	TH 130	R & P For Minor Roles	29215	ART 298	Directed Studies
21172	TH 131	R & P For Supporting Roles	23662	ASTR 102	Intro Astron Stars Univrse
21173	TH 132	R & P For Lead Roles	29588	AUTO 107	Diesel Exhaust Emission Contro
22328	TH 133	Stage Crew Activity	29589	AUTO 155	Med/Heavy Duty Brake Systems
27091	TH 133	Stage Crew Activity	29597	AUTO 195	Auto Customer Relations
22330	TH 134	Technical Production	22004	BA 100	Fundamentals of Business
29712	WGS 115	Gender,Comm,&the Digital Revol	20815	BA 100	Fundamentals of Business
27063	WGS 208	Leadership for Women in Bus	22000	BA 113	Legal Environment of Business
1st TWELVE WEEKS: 01/13/2020-04/10/2020					
29606	ET 105	Industrial Motor Control	22001	BA 115	Management-Business
1st FIFTEEN WEEKS: 01/13/2020-05/01/2020					
20205	ART 101	Art History I	22006	BA 153	Small Business Management
22878	ART 102	Art History II	23770	BA 155	Intro Global Logistics
28725	ART 107	Asian Art History	24207	BCOT 113	Microsoft Excel
29591	AUTO 182	Intro to Alternative Fuel	26165	BCOT 155	Admin Secretarial Procedrs
20230	ART 191A	3d Computer Animation	21114	CIS 101	Intro Computer Info Systms
26985	ART 191B	3d Computer Animation Proj	26851	CIS 103	Computer Programming Logic
23574	ART 193	Motion Picture Editing	28285	CIS 103	Computer Programming Logic
26339	ART 194A	Advanced Final Cut Pro	30134	CIS 180	Programming in C/C++
24203	BA 100	Fundamentals of Business	30135	CIS 180	Programming in C/C++
21759	BA 113	Legal Environment of Business	29049	CIS 189C	Special Topics in SW Dvprmt
23914	BA 113	Legal Environment of Business	21919	CIS 202A	Project Management for IT
22007	BA 115	Management-Business	30083	COMM 100	Intro to Communication Studies
28580	BA 126	E-learning	29928	COMM 100	Intro to Communication Studies
23026	BA 156	Motivational Skills/Mgrs	29926	COMM 100	Intro to Communication Studies
23771	BA 205	Organizational Leadership	29981	COMM 103	Argumentation,Persuasion,Crit,
25732	BA 208	Leadership for Women in Bus	29982	COMM 103	Argumentation,Persuasion,Crit,
22300	ECON 101	Econ Issues and Policy	29942	COMM 115	Gender,Comm,&DigitalRevolution
23339	ECON 201	Principles of Macroeconomics	29952	COMM 120	Interpersonal Communication
23341	ECON 201M	Principles of Macroeconomics	29963	COMM 130	Public Speaking
22592	ECON 202M	Principles of Macroeconomics	29964	COMM 130	Public Speaking
22359	EDEL 100	Introduction To Teaching	29968	COMM 132	Small Group Communication
24177	EDEL 100	Introduction To Teaching	29969	COMM 140	Oral Interpretation Of Lit
28593	EDEL 100	Introduction To Teaching	29970	COMM 145	Storytelling
21642	EDEL 105	Intro to Teaching	27196	COS 54A	Advanced Esthetician
25308	ENGL 103	Critical/Argumentative Wrt	22276	COUN 200	Success College and Career
28052	HIST 103	Political & Social Hist-U.S.	20390	ENGL 100	Freshman Composition
24196	WGS 208	Leadership for Women in Bus	23746	ENGL 100	Freshman Composition
			29208	ENGL 100	Freshman Composition
			29209	ENGL 100	Freshman Composition
			29782	ENGL 100S	Enhanced Freshman Composition
			29790	ENGL 100S	Enhanced Freshman Composition
			29798	ENGL 100S	Enhanced Freshman Composition
			29784	ENGL 100S	Enhanced Freshman Composition
			29792	ENGL 100S	Enhanced Freshman Composition
			29800	ENGL 100S	Enhanced Freshman Composition
			27292	ECON 101	Econ Issues and Policy

Attendance is mandatory (including wait listed students). Failure to appear will jeopardize your official enrollment.

SHORT TERM CLASSES

Class#	Course	Description	Class#	Course	Description
26394	ECON 101	Econ Issues and Policy	2nd SIX WEEKS: 2/24/2020-04/10/2020		
30147	ENGL 102	Introduction to Literature	28745	COUN 101B	Educational Planning
21650	ENGL 103	Critical/Argumentative Wrt	25238	COUN 101B	Educational Planning
28260	ENGL 103	Critical/Argumentative Wrt	27076	HO 54	Medical Laboratory Skills
28261	ENGL 103	Critical/Argumentative Wrt	2nd NINE WEEKS: 03/23/2020-05/22/2020		
28890	ENGL 103	Critical/Argumentative Wrt	29573	AB 57	Structural Auto Welding
29869	ENGL 110	Critical Thinking Through Lit	28753	AB 64	Automotive Air Brush Painting
28559	ENGL 226	African-American Literature	28650	AB 83A	Computerized Damage Estimating
26889	ENGL 228	Shakespeare's Plays	27051	AB 83P	Computer Damage Est - Pathways
21665	ENGL 235	Readings in the Drama	22733	ACCT 61	Turbo Tax Accounting
29870	ENGL 239	Literature of India	22376	ANCLR 91	Career Exploration/Disab
20402	ENGL 246B	Survey of Eng Lit B:Romantics	29690	ANTH 115	Physical Anthropology
29872	ENGL 249	LGBT Literature	29714	ART 105B	Latin American Art
20409	ESL 3	ESL Grammar, Read, & Writing 3	29877	ASL 216	Beg Interpreting & Ethics 2
29873	ESL 4	ESL Grammar,Reading&Writing 4	20243	ASTR 103	Intro Astron Solar System
23403	ESL 4	ESL Grammar,Reading&Writing 4	25127	ATH 205LD	Basketball, Women, Off Season
23407	ESL 5	ESL Grammar,Reading,&Writing 5	25134	ATH 215LB	Soccer, Women, Off Season
29875	ESL 10	ESL Speaking & Listening 1	27916	AUTO 73	Auto Occupational Work Exp
29876	ESL 20	ESL Speaking & Listening 2	21093	AUTO 73	Auto Occupational Work Exp
28563	ESL 2	ESL Speaking & Listening 2	21050	AUTO 121	Drivetrain Trans and Axles
30074	ESL 21A	ESL Intermed Vocabulary	27977	AUTO 121	Drivetrain Trans and Axles
25844	ESL 57	TOEFL Preparation Course	21110	AUTO 151	Auto Alignment Brake/Susp
23421	ESL 120	Prep For Col Writing-NonEngl	23913	BA 100	Fundamentals of Business
25875	ESL 152	IntroCol Comp Non-Native Engl	26855	BA 100	Fundamentals of Business
22535	FILM 160	Great Film Directors	20816	BA 101	International-Business
22537	FILM 241	Screenwriting	27218	BA 104	Managing Cultural Diversity
22060	FIN 125	Personal Finance	29026	BA 104	Managing Cultural Diversity
23471	FIN 125	Personal Finance	23896	BA 106	Human Resource Management
28084	FIN 125	Personal Finance	26159	BA 106	Human Resource Management
28708	GEOG 101	Physical Geography	26708	BA 106	Human Resource Management
29192	GEOG 298	Directed Studies	29159	BA 106	Human Resource Management
28243	HIST 102	Political & Social Hist-U.S.	29213	BA 106	Human Resource Management
24181	HIST 110	African/American History	29691	BA 106	Human Resource Management
20447	HIST 250	Hist of England/Brit/Comwl	27316	BA 107	Human Relations In Bus
29707	HIST 255	Hist-Russia-Soviet Union	28497	BA 107	Human Relations In Bus
22386	HIST 275	Global Studies	29184	BA 107	Human Relations In Bus
25348	KIN 299	Directed Studies	29160	BA 108	Labor Management Relations
29135	LAW 101	Introduction To Law	29161	BA 109	Human Resource Development
28662	LAW 110	Business Law	27732	BA 110	Advertising
27084	MATH 114	College Algebra	27456	BA 113	Legal Environment of Business
29024	MATH 114	College Algebra	29027	BA 113	Legal Environment of Business
24186	POL 101	American Political Institution	21996	BA 114	Marketing
27323	POL 101	American Political Institution	26675	BA 114	Marketing
23355	POL 101	American Political Institution	26719	BA 114	Marketing
20993	POL 101	American Political Institution	29028	BA 114	Marketing
22640	POL 101	American Political Institution	23036	BA 115	Management-Business
27726	PSYC 265	Psychology of Gender	26161	BA 115	Management-Business
22070	RE 131	Int Real Estate Appraisal	26325	BA 115	Management-Business
25739	RE 157	Real Estate Investments	28090	BA 115	Management-Business
28585	RE 160	Real Estate Economics	27318	BA 117	Introduction To Supervision
21835	RTV 151	Motion Pictures/Radio & TV	22865	BA 118	Retail Management
25771	SOC 101	Intro Sociology-Principles	23478	BA 118	Retail Management
24192	SOC 101	Intro Sociology-Principles	26690	BA 118	Retail Management
21022	SOC 110	Marriage and the Family	27315	BA 118	Retail Management
24193	SOC 202	Gender and Society	28093	BA 120	Mgmt-Act & Internal Contrl
28037	SOC 202	Gender and Society	28578	BA 120	Mgmt-Act & Internal Contrl
22304	SOC 205	Intro to Soc Research Methods	28579	BA 120	Mgmt-Act & Internal Contrl
26865	SOC 298	Directed Studies	26828	BA 121	Sales
28737	TH 110	Fundamentals of Acting	23024	BA 132	Computer Applications/Mgrs
27212	TH 114	Voice for Acting	25870	BA 132	Computer Applications/Mgrs
21784	TH 151	Motion Pictures/Radio & TV	27007	BA 132	Computer Applications/Mgrs
20763	TH 150	App & Hist Motion Picture	28094	BA 132	Computer Applications/Mgrs
21627	TH 150	App & Hist Motion Picture	21525	BA 152	Fund Importing/Exporting
21045	WGS 101	Issues Women Amer Society	27320	BA 153	Small Business Management
29713	WGS 115	Gender,Comm,&the Digital Revol	27737	BA 156	Motivational Skills/Mgrs
28122	WGS 202	Gender and Society	29693	BA 156	Motivational Skills/Mgrs
27065	WGS 202	Gender and Society	28096	BA 157	Principles of Public Relations
28778	WGS 250	Foundations,Feminist,Gender,Qu	27322	BA 204	Project Management
28297	WGS 298	Directed Studies	29162	BA 205	Organizational Leadership
28298	WGS 299	Directed Studies			

Attendance is mandatory (including wait listed students). Failure to appear will jeopardize your official enrollment.

SHORT TERM CLASSES

Class#	Course	Description	Class#	Course	Description
29029	BA 208	Leadership for Women in Bus	30054	MATH 116	Calc for Manag-Biol-Soc Sc
22140	BCOT 118	MS Access for Office	29685	MATH 140	Trigonometry
29706	BCOT 150	International Bus Comm	30008	MATH 140	Trigonometry
25737	BCOT 161	Principles of Filing	30009	MATH 140	Trigonometry
21112	BCOT 63	Keyboarding Speed/Control	30047	MATH 155	Precalculus
29166	BCOT 96	Microsoft PowerPoint	30049	MATH 190	Analytic Geom & Calc II
21517	BCOT 97	Microsoft Outlook	22880	MUS 104B	History of Rock Music
21113	CA 101	Intro/Food Serv Safety-San	25260	MUS 208E	Pop/Rock Latin Ensemble
26923	CDEC 63	Ece In Lang/Arts & Soc Sci	25160	NRSNG 25	Clinical Workshop 1
27793	CIS 101	Intro Computer Info Systems	21058	NRSNG 26	Clinical Workshop 2
24149	CIS 170B	Network + Certification	21121	NRSNG 212	Medical-Surgical Nursing I
26866	CIS 170H	TCP/IP Fundamentals	21122	NRSNG 212	Medical-Surgical Nursing I
20310	CIS 58B	PC Core Hardware A+ Cert	21123	NRSNG 212	Medical-Surgical Nursing I
26106	CIS 58B	PC Core Hardware A+ Cert	21124	NRSNG 212	Medical-Surgical Nursing I
30082	COMM 100	Intro to Communication Studies	21125	NRSNG 212	Medical-Surgical Nursing I
29941	COMM 110	Intercultural Communication	21653	NRSNG 215	Advanced Placement Bridge
29944	COMM 115	Gender,Comm,&DigitalRevolution	21127	NRSNG 222	Maternal/Child Nursing
29972	COMM 125	Organizational Communication	21161	NRSNG 222	Maternal/Child Nursing
29958	COMM 130	Public Speaking	21162	NRSNG 222	Maternal/Child Nursing
29973	COMM 200	Contemporary Comm Topics	23291	NRSNG 222	Maternal/Child Nursing
30117	COS 55	Esthetics Crossover	26064	NRSNG 222	Maternal/Child Nursing
22290	COS 60B	Intro Cosmetology II	21130	NRSNG 232	Medical-Surgical Nursing 4
22294	COS 61B	Intermed Cosmetology II	21131	NRSNG 232	Medical-Surgical Nursing 4
22298	COS 62B	Advanced Cosmetology II	21132	NRSNG 232	Medical-Surgical Nursing 4
29134	COS 99	Directed Studies	21163	NRSNG 232	Medical-Surgical Nursing 4
26660	COUN 10	Career Planning	21164	NRSNG 232	Medical-Surgical Nursing 4
27348	COUN 10	Career Planning	30158	PEX 100	Fitness for Student's with Dis
27022	COUN 101C	Navigating the Transfer Process	30162	PEX 103	Adapted Strength Training
29997	COUN 200	Success College and Career	30166	PEX 104	Adapted Stretching & Relaxatio
22831	DANC 100	Dance Appreciation	25378	PEX 105	Adapted Swimming
28259	DANC 100	Dance Appreciation	28821	PEX 106	Adapted Aquatic Exercise
28295	DANC 100	Dance Appreciation	26318	PEX 116	Water Aerobics
29216	DANC 100	Dance Appreciation	29223	PEX 124	Personal Fitness Program
27729	ECON 202	Principles of Microeconomics	25402	PEX 124	Personal Fitness Program
24175	ECON 202M	Principles of Microeconomics	28247	PEX 136	Stretching and Relaxation
29695	EDT 116	Information Literacy for Ed	25458	PEX 145	Circuit Weight Training, Beg
29696	EDT 123	Internet Tools for Educators	28984	PEX 165	Basketball, Novice
29694	EDT 132	Using Audio in the Classroom	28986	PEX 166	Basketball, Beginning
27745	EDT 135	Slide Presentation Software	26880	PEX 172	Flag Football
29697	EDT 141	Web Design for Educators	25518	PEX 179	Soccer, Fitness and Technique
27748	EDT 170	Using A CMS/LMS For Ed	27272	PEX 184	Swimming, Novice
28586	EDT 50	Prep for Online Learning	27274	PEX 185	Swimming, Beginning
28996	ENGL 100	Freshman Composition	28988	PEX 265	Basketball, Intermediate
28280	ENGL 100	Freshman Composition	28990	PEX 266	Basketball, Advanced
29865	ENGL 103	Critical/Argumentative Wrt	21167	PHAR 50	Pharmaceutics
29205	ENGL 103	Critical/Argumentative Wrt	20641	PHAR 63	Pharmacy Operations II
26757	ESL 31	ESL Reading 2	28693	PHYS 203	Engineering Physics
27289	ESL 152	IntroCol Comp Non-Native Engl	28965	PMT 72	Tooling for Plastics
28226	GEOG 105	World Regional Geography	27281	POL 101	American Political Institution
21572	HED 100	Contemp Health Problems	20684	PSYC 101	General Introductory Psyc
22604	HED 100	Contemp Health Problems	20995	PSYC 101	General Introductory Psyc
26835	HED 100	Contemp Health Problems	22634	PSYC 241	Introduction to Psychology
29222	HED 100	Contemp Health Problems	23506	RE 130	Real Estate Practice
29732	HED 100	Contemp Health Problems	29187	SOC 101	Intro Sociology-Principles
20422	HED 100	Contemp Health Problems	28215	TH 101	Intro to the Theatre
23267	HED 100	Contemp Health Problems	28740	TH 101	Intro to the Theatre
30090	HED 101	Stress Management	21106	TH 130	R & P For Minor Roles
30091	HED 101	Stress Management	21107	TH 131	R & P For Supporting Roles
20435	HED 103	Women, Their Bodies/Health	21108	TH 132	R & P For Lead Roles
24178	HIST 102	Political & Social Hist-U.S.	21787	TH 133	Stage Crew Activity
22385	HIST 103	Political & Social Hist-U.S.	21789	TH 134	Technical Production
20449	HUM 100	The Art of Being Human	27451	TH 136	Tour Theatre/Support Roles
28141	KIN 100	Introduction to Kinesiology	27449	TH 137	Touring Theatre For Leads
28843	KIN 100	Introduction to Kinesiology	25727	TH 146	Music Theatre For Chorus
29193	KIN 100	Introduction to Kinesiology	25729	TH 147	Music Theatre For Leads
29221	KIN 100	Introduction to Kinesiology	23707	WGS 103	Women, their Bodies and Health
28115	KIN 100	Introduction to Kinesiology	28137	WGS 108	Women in Sports
27222	KIN 108	Women in Sports	28777	WGS 115	Gender,Comm,&the Digital Revol
25346	KIN 298	Directed Studies	29030	WGS 208	Leadership for Women in Bus
22913	MATH 60	Elementary Algebra			
26270	MATH 60	Elementary Algebra			
20501	MATH 80	Intermediate Algebra			
28698	MATH 80	Intermediate Algebra			
29226	MATH 112	Elementary Statistics			
30140	MATH 114	College Algebra			

Attendance is mandatory (including wait listed students). Failure to appear will jeopardize your official enrollment.

SHORT TERM CLASSES

Class#	Course	Description	Class#	Course	Description
--------	--------	-------------	--------	--------	-------------

3rd SIX WEEKS: 04/13/2020-05/22/2020

25237	COUN 101B	Educational Planning
29566	COUN 101A	Orientation to College
25166	PTA 250	Licensure Examination Prep
25233	NRSG 213A	Major Drugs and Nursing I

SIXTEEN WEEKS – WEEKEND CLASSES: 01/17/2020-05/17/2020

27283	CD 110	Child Development
29930	COMM 100	Intro to Communication Studies
29966	COMM 130	Public Speaking
26657	DANC 106A	Beginning Ballet
22158	DANC 106B	Intermediate Ballet
22160	DANC 107	Ballet Variations
26735	ENGL 100	Freshman Composition
28997	ENGL 100	Freshman Composition
20398	ENGL 103	Critical/Argumentative Wrt
29005	ENGL 103	Critical/Argumentative Wrt
28963	ENGT 116	Blueprint Reading
29604	ENGT 263	SolidWorksforIndustrialMoldDes
22926	ET 101	Principles of Engineering Tech
27895	FILM 104	Motion Picture & Digital Cinem
26306	MTT 100	Machine Tool Introduction
25689	PHOT 100	Introductory Photography
27107	SPAN 101	Elementary Spanish
28143	SPAN 102	Elementary Spanish
28616	WELD 100	Welding Fundamentals
23548	WELD 240L	Inter Gas Tungsten Arc Welding
23549	WELD 250L	Adv Gas Tungsten Arc Welding
23550	WELD 260L	Gas Tungsten Arc Weld-Aerospac
28110	WELD 54L	Advanced Pipe Welding
28190	WELD 56L	Arc Welding 6" Pipe Cert Lab
28191	WELD 58L	Arc Welding 2" Pipe Cert Lab
24251	WMT 101	Intro to Woodworking
21091	WMT 107	Wood Finishing
24256	WMT 111L	Intro to Woodworking Lab
29614	WMT 151	Intro Faceframe Cabinet
29625	WMT 269L	Cabinet Mfgt Specialty Lab
26206	WELD 120	Beginning Arc Welding

1st EIGHT WEEKS: 01/17/2020-03/15/2020

26450	KIN 123	Sports Officiating Track&Field
26195	MTT 68	Computer-Assisted Inspection

2nd EIGHT WEEKS: 03/27/2020-05/17/2020

27817	MTT 78	Tool Building Using Verisurf
-------	--------	------------------------------

4th SIX WEEKS: 03/23/2020-05/01/2020

21513	NRSG 242	Professional Role Transiti
21514	NRSG 242	Professional Role Transiti
21515	NRSG 242	Professional Role Transiti
21516	NRSG 242	Professional Role Transiti

Attendance is mandatory (including wait listed students). Failure to appear will jeopardize your official enrollment.



NO FEE NON-CREDIT CLASSES

The following information will help you register for non-credit classes offered by Cerritos College. In non-credit classes students build the basic skills needed for personal and professional growth. Students in non-credit classes do not earn units toward the award of a credit degree or certificate, and are not required to pay registration fees for these courses. Instruction in English as a Second Language, General Education Development Preparation, Citizenship, Math and English support, other basic skills are offered within the non-credit Adult Education unit. Some classes are offered in both English and Spanish. Most non-credit classes take place off-campus at community sites. Classes for students with disabilities require a separate registration process.

More information is available by calling the offices of:
 Adult Education(562) 467-5098
 Emeritus - Older Wiser Learner(562) 467-5098

REGISTRATION

STEPS TO ENROLL IN NON-CREDIT CLASSES

1. IDENTIFY THE CLASS OR CLASSES YOU WISH TO TAKE
Review the course list and identify class and ticket number.
2. COMPLETE REGISTRATION FORM
Complete a Cerritos College application online at www.cerritos.edu; select "Apply Online".
3. WALK-IN REGISTRATION
You may register online or in person at the Office of Adult Education & Diversity Programs. Call (562) 467-5098 for office hours.
If you are registering for an ESL, or Vocational ESL, or GED class, an assessment test will need to be taken.
4. SCHEDULE AN APPOINTMENT WITH COUNSELOR
Counselors are available to talk with you about the right courses for you. Call (562) 467-5098 to schedule an appointment.

CLASES GRATIS DE NO-CREDITO DEL COLEGIO

Lo siguiente le ayudará a matricularse para clases de no-crédito del Colegio de Cerritos. En las clases de no-crédito, los estudiantes mejoran sus habilidades académicas básicas necesarias para el desarrollo personal y profesional. Las clases de no-crédito no se aplican para título o certificado en los programas de crédito. Se ofrecen clases de Inglés como Segundo Idioma, Diploma de Preparatoria, Ciudadanía, y apoyo en Matemáticas y Lectura, otras clases de habilidades académicas. La mayoría de las clases de no-crédito se ofrecen en sitios distintos de la comunidad. Clases para estudiantes con discapacidades requieren de una matriculación aparte.

Para información en español, llame a las oficinas de:
 Educación de Adultos (562) 467-5098
 Programa de educación para adultos de mayor edad (562) 467-5098

REGISTRACIÓN

COMO MATRICULARSE EN CLASES DE NO-CRÉDITO

1. Escoja la clases o clase que le gustaria tomar.
2. Llene la aplicacion de registración para Cerritos College por internet www.cerritos.edu, presione Apply Online, opción en Español.
3. Registracion en persona.
Al llenar la aplicacion de registración, venga a la oficina de Educacion para Adultos localizada en el edificio de CE 11.
Registración para los cursos de Inglés Como Segundo Idioma requieren una prueba de evaluación. Llame la oficina para mas información (562) 467-5098.
4. Consulte con un consejero.
Consejeros que hablan español están disponibles. Para hacer una cita, llame al (562) 467-5098.

Class#	Time	Day	Instructor	Room	Class#	Time	Day	Instructor	Room
--------	------	-----	------------	------	--------	------	-----	------------	------

CITIZENSHIP

This course prepares adults for the citizenship process, the INS examination, and interview. The course will also emphasize communication and strengthen English language skills for those limited in English.

Prepárese para el examen de ciudadanía y la entrevista con inmigración, aprendiendo al mismo tiempo Inglés.

AED 60.01 - 0.0 UNIT CITIZENSHIP

Not Transferable

30214	8:30- 12:20PM	T	Martinez,D	MESP*
30217	9:00- 10:50AM	TTh	STAFF	PADL*
28168	8:00- 12:15PM	Sat	Nunez,M	CB101
Class# 28168 meets 01/18/2020-05/16/2020				
28188	8:00- 12:15PM	Sat	Lozano,J	CCHA*
Class# 28188 meets 01/18/2020-05/16/2020				
28148	9:00- 12:50PM	F	Maris-Gramajo,E	SNPK*
Class# 28148 meets 01/17/2020-05/15/2020				
30213	8:00- 12:15PM	Sat	Cardona,R	CCHA*
Class# 30213 meets 01/18/2020-05/16/2020				

ENGLISH AS A SECOND LANGUAGE

Five levels are offered to assist you in your language development. Emphasis is placed on oral communication and conversational language.

Cinco niveles de Inglés se ofrecen para ayudarle a desarrollar sus conocimientos del idioma Inglés. Esta clase está enfocada en comunicación oral y conversación del idioma Inglés.

AED 42.14 - 0.0 UNIT LOW BEGINNING ENGLISH AS A SECOND LANGUAGE

Not Transferable

28939	6:00- 8:50PM	TTh	Leguizamon-Tunnell,C	CE 7
-------	--------------	-----	----------------------	------

AED 42.15 - 0.0 UNIT HIGH BEGINNING ENGLISH AS A SECOND LANGUAGE

Not Transferable

28903	6:00- 8:50PM	MW	Fragoso,M	CB102
-------	--------------	----	-----------	-------

AED 42.16 - 0.0 UNIT LOW INTERMEDIATE ENGLISH AS A SECOND LANGUAGE

Not Transferable

20087	8:30-11:20AM	MW	Mondaca,F	CE 1
20082	8:30- 2:55PM	Sat	Tucker,J	SL107
Class# 20082 meets 01/18/2020-05/16/2020				

AED 42.17 - 0.0 UNIT HIGH INTERMEDIATE ENGLISH AS A SECOND LANGUAGE

Not Transferable

26372	6:00- 8:50PM	MW	Amanat-Lee,J	CE 7
28192	8:30- 11:20AM	TTh	Nunez Jr.,N	CE
29067	8:30- 2:55PM	Sat	Sanchez,S	SL108
Class# 29067 meets 01/18/2020-05/16/2020				

AED 42.18 - 0.0 UNIT LOW ADVANCED ENGLISH AS A SECOND LANGUAGE

Not Transferable

Prerequisite: Pass AED 42.17 High Intermediate English as a Second Language course or assess into AED 42.18.

27995	8:30- 11:20AM	MW	Nunez Jr.,N	MO
27649	6:30- 9:20PM	MW	Nunez,M	CE 2
30196	8:30- 2:55PM	Sat	Nunez Jr.,N	SL
Class# 30196 meets 01/18/2020-05/16/2020				

SURVIVAL ESL

This first course in a series is designed as a survival-level English language course for those students with no English language skills. All language learning skills will be utilized: reading, writing, listening, and speaking; the main focus will be on vocabulary building and listening as initial steps for building English language acquisition.

Este curso de Inglés básico de sobrevivencia está diseñado para aquellos estudiantes con pocas habilidades en este idioma. Todas las enseñanzas del lenguaje aprendido podrán ser utilizadas: Leyendo, escribiendo, escuchando y hablando. El tema central es el vocabulario. Construyendo vocabulario y escuchando es el paso inicial para adquirir el lenguaje Inglés.

AED 42.03 - 0.0 UNIT SURVIVAL ESL

Not Transferable

28902	8:30- 11:20AM	TTh	Mobley,T	CE 2
B8948	6:00- 8:50PM	TTh	Perez Juarez,M	CE 2
30215	9:00- 11:50AM	MW	Lozano,J	MESP*
30193	8:30- 2:55PM	Sat	Robles,M	CE 2
Class# 30193 meets 01/18/2020-05/16/2020				

VOCATIONAL ENGLISH AS A SECOND LANGUAGE

This course is designed as a survey of work-related communication including nomenclature for the student with limited English language skills. Students will learn to recognize, produce, and understand technical vocabulary utilizing language learning skills: speaking, listening, reading and writing. Students will learn about vocation and nomenclature, while increasing their English language acquisition by learning to ask and respond to questions related to the vocation and practice conversation on a variety of work-related subjects. Students will expand their vocational knowledge via class discussions, reading print material, attending field trips, and by sharing their vocational experiences with other students. This course is intended as preparation for future credit courses, vocational training, or increased vocational language acquisition for the work situation.

Este curso está diseñado para la comunicación en los trabajos, incluye nomenclatura para el estudiante limitado en el idioma Inglés. Los estudiantes aprenderán a reconocer, pronunciar y entender el vocabulario técnico por medio de escuchar, hablar, escribir y leer. Este curso tiene el objetivo de prepararlo para futuras clases de crédito, entrenamientos vocacionales o incrementar la adquisición del lenguaje necesario para una situación en el trabajo.

AED 49.02 - 0.0 UNIT VOCATIONAL ENGLISH AS A SECOND LANGUAGE

Not Transferable

26376	9:00- 11:05AM	MW	Robles,M	ABBS*
26481	2:30- 4:20PM	TTh	Ramos,M	NOR *
30197	9:00- 11:05AM	MW	Mobley,T	TMJF*
27243	8:30- 12:55PM	F	Perez Juarez,M	MESP*
Class# 27243 meets 01/17/2020-05/15/2020				
30198	9:00- 1:50PM	Sat	Fragoso,M	SNPK*
Class# 30198 meets 01/18/2020-05/16/2020				

Students not in attendance or late for the first class meeting are subject to drop.

Class#	Time	Day	Instructor	Room	Class#	Time	Day	Instructor	Room
--------	------	-----	------------	------	--------	------	-----	------------	------

COLLEGE ENGLISH SKILLS

This beginning course is designed for students already able to understand and speak the English language. This course is not recommended for students working on secondary language skills who would be better served by an ESL course. It is intended to reduce beginning writing students' fear and anxiety about writing. It develops writing fluency through written activities and assignments designed to teach and reinforce conventions of Standard English. This course focuses on sentence structure and development and sentence combining. Students will work toward developing short paragraphs.

Este curso está diseñado para desarrollar la escritura combinando actividades y tareas diseñadas para reforzar las habilidades de escritura en el idioma inglés.

AED 48.05 - 0.0 UNIT COLLEGE ENGLISH SKILLS

Not Transferable

27146	9:00- 10:00AM	MW	Morrison,A	MP103
	10:00- 11:00AM	MW	Morrison,A	MP103
27144	9:00- 10:00AM	TTh	Robles,M	MP103
	10:00- 11:00AM	TTh	Robles,M	MP103
30207	9:00- 11:10AM	Sat	Amanat-Lee, J	MP105
	11:10- 1:15PM	Sat	Amanat-Lee, J	MP105
Class# 30207 meets 01/18/2020-05/16/2020				

PREPARATORY MATHEMATICS

This course is for students who wish to master basic mathematical skills in order to pursue subsequent mathematical courses, gain personal enrichment, and develop career readiness. It covers the concepts of addition, subtraction, multiplication and division of whole numbers, fractions, mixed numbers, decimals, and percentages, with an emphasis on real-world applications

Este curso es para estudiantes que deseen dominar las bases en matemáticas para que pueden alcanzar sus siguientes cursos de matemáticas, desarrollo interpersonal y enriquecimiento de sus habilidades. La clase cubre conceptos de adición, sustracción, multiplicación, fracciones y números mixtos, decimales y porcentajes, con un énfasis en problemas de palabras..

AED 49.01 - 0.0 UNIT PREPARATORY MATH

Not Transferable

27175	9:00- 10:00AM	MW	Barrera De Contreras	MP104
	10:00- 10:50AM	MW	Barrera De Contreras	MP104
27162	6:30- 7:40PM	TTh	Barrera De Contreras	MP103
	7:40- 8:40PM	TTh	Barrera De Contreras	MP103
Class# 27162 meets 02/04/2020-05/21/2020				
27164	8:00- 10:10AM	F	Barrera De Contreras	MP103
	10:10- 12:15PM	F	Barrera De Contreras	MP103
Class# 27164 meets 01/17/2020-05/15/2020				
27160	8:00- 10:10AM	Sat	Barrera De Contreras	MP103
	10:10- 12:15PM	Sat	Barrera De Contreras	MP103
Class# 27160 meets 01/18/2020-05/16/2020				

COLLEGE PLACEMENT STRATEGIES A

This course will build pre-college level proficiency to prepare students for the community college assessment test in reading comprehension and sentence skills. Students will develop fundamental concepts of reading and writing and gain familiarity with the basic testing format. The combination lecture/lab format will expose students to various mediums of instruction and strengthen their knowledge of testing strategies. This course is presented in a modular format

Este curso le ayudara a desarrollar sus habilidades de comprensión y escritura a nivel preuniversitario. Los estudiantes desarrollaran conceptos fundamentales de lectura y escritura y se familiarizaran con el formato de examen básico. Este curso se presentara en un formato modular.

AED 42.98 - 0.0 UNIT COLLEGE PLACEMENT TESTING STRATEGIES A

Not Transferable

30209	11:30- 12:40PM	TTh	Mobley,T	MC101
	12:40- 1:40PM	TTh	Mobley,T	MC101
Class# 30209 meets 02/04/2020-05/21/2020				
30211	9:00- 10:05AM	TTh	Mobley,T	AT 54
	10:05- 11:10AM	TTh	Mobley,T	AT 54
Class# 30211 meets 02/04/2020-05/21/2020				
30223	2:00- 3:10PM	MW	Morrison,A	TBA*

	3:10- 4:10PM	MW	Morrison,A	TBA*
Class# 30223 meets 02/03/2020-05/20/2020				
30253	3:00- 4:10PM	MW	Oviedo,A	TBA*
	4:10- 5:10PM	MW	Oviedo,A	TBA*
Class# 30253 meets 02/03/2020-05/20/2020				
30255	4:00- 5:10PM	MW	Oviedo,A	TBA*
	5:10- 6:10PM	MW	Oviedo,A	TBA*
Class# 30255 meets 02/03/2020-05/20/2020				
30257	5:00- 6:10PM	MW	Oviedo,A	TBA*
	6:10- 7:10PM	MW	Oviedo,A	TBA*
Class# 30257 meets 02/03/2020-05/20/2020				
30259	2:00- 3:10PM	TTh	Nunez Jr.,N	TBA*
	3:10- 4:10PM	TTh	Nunez Jr.,N	TBA*
Class# 30259 meets 02/04/2020-05/21/2020				
30261	3:00- 4:10PM	TTh	Nunez Jr.,N	TBA*
	4:10- 5:10PM	TTh	Nunez Jr.,N	TBA*
Class# 30261 meets 02/04/2020-05/21/2020				
30263	4:00- 5:10PM	TTh	Nunez Jr.,N	TBA*
	5:10- 6:10PM	TTh	Nunez Jr.,N	TBA*
Class# 30263 meets 02/04/2020-05/21/2020				
30265	5:00- 6:10PM	TTh	Nunez Jr.,N	TBA*
	6:10- 7:10PM	TTh	Nunez Jr.,N	TBA*
Class# 30265 meets 02/04/2020-05/21/2020				

COLLEGE PLACEMENT STRATEGIES B

This course will build pre-college level math skills to prepare students for the community college assessment test in arithmetic and algebra. Students will gain conceptual knowledge, practice basic computations, and use analytical thinking to solve problems. The combination lecture/lab will provide a foundation for basic math concepts and testing strategies while familiarizing students with the basic testing format. This course is presented in a modular format.

Este curso le ayudara a desarrollar sus habilidades de comprensión y escritura a nivel preuniversitario. Los estudiantes desarrollaran conceptos fundamentales de lectura y escritura y se familiarizaran con el formato de examen básico. Este curso se presentara en un formato modular.

AED 42.99 - 0.0 UNIT COLLEGE PLACEMENT TESTING STRATEGIES B

Not Transferable

28926	1:30- 2:40PM	MW	Nunez Jr.,N	NBA
	2:40- 3:40PM	MW	Nunez Jr.,N	NBA
Class# 28926 meets 01/13/2020-05/20/2020				
28928	12:15- 1:25PM	Sat	Barrera De Contreras	MP103
	1:25- 2:05PM	Sat	Barrera De Contreras	MP103
Class# 28928 meets 01/18/2020-05/15/2020				
28930	11:00- 12:00PM	MW	Barrera De Contreras	MP104
	12:00- 12:50PM	MW	Barrera De Contreras	MP104
Class# 28930 meets 01/13/2020-05/20/2020				

CAREER SKILLS

The Career Skills course is tailored to help students build or improve their interpersonal skills in the workplace. The course will allow students to develop a broad range of knowledge in several work related areas such as goal setting, clear and effective communication, collaboration skills, and personal strengths. Students will develop soft workplace skills to experience new success in their current or prospective job setting.

Esta clase le dará las herramientas necesarias para aplicar aun trabajo y le ayudara como llevar a cabo una entrevista, administrar el tiempo, sobrellevar el estrés y crear ética laboral.

AED 22.06 - 0.0 UNIT CAREER SKILLS

Not Transferable

30202	6:00- 7:50PM	MW	Martinez,D	SNPK*
30204	8:30- 10:20AM	TTh	Correa,R	FISA*
30205	10:30- 12:20PM	TTh	Maris-Gramajo,E	TMJF*
30206	6:30- 8:40PM	TTh	Lopez,A	MC101
Class# 30206 meets 02/04/2020-05/21/2020				
30203	9:00- 12:50PM	TTh	Mansell,B	COCC*
Class# 30203 meets 03/24/2020-05/22/2020				

Students not in attendance or late for the first class meeting are subject to drop.

Class#	Time	Day	Instructor	Room	Class#	Time	Day	Instructor	Room
--------	------	-----	------------	------	--------	------	-----	------------	------

OCCUPATIONAL TRAINING

Occupational Training will enhance students' skills to enter a new job position and/or advance in their current work. The goal of the course is to advance students' technical skills to apply for a new job or to acquire a job advancement.

Este entrenamiento le ayudara al estudiante a mejorar sus habilidades para empezar un nuevo trabajo o ascender de posición en el área laboral. La meta de este curso es proporcionar al estudiante con las herramientas técnicas para aplicar a un nuevo trabajo o lograr crecimiento profesional.

AED 36.06 - 0.0 UNIT OCCUPATIONAL TRAINING

Not Transferable

30199	8:30- 10:40AM	TTh	Morales,L	MC101
Class# 30199 meets 02/04/2020-05/21/2020				
30200	6:00- 8:10PM	TTh	STAFF	SL108
Class# 30200 meets 02/04/2020-05/21/2020				
30201	9:00- 12:50PM	TTh	Mansell,B	COCC*
Class# 30201 meets 01/14/2020-03/12/2020				

GENERAL EDUCATION DEVELOPMENT PREPARATION (GED)

This GED course consists of five examinations in the areas of writing skills, social studies, science, literature, the arts and mathematics. This course will prepare students to take the battery of GED tests.

Este curso consiste en cinco materias que son escritura, ciencias sociales, literatura, arte y matematicas. Estas clases lo capacitan para pasar el examen y obtener su certificado de preparatoria

AED 42.10 - 0.0 UNIT SPANISH GED TEST PREP-A

Not Transferable

30188	4:35- 7:25PM	TTh	Ramos,M	NOR *
30189	6:00- 8:50PM	TTh	Chavez-De Vasquez,A	COCC*
30216	10:00- 12:50PM	MW	STAFF	CGLB*
28946	8:30- 2:55PM	Sat	lachetta,C	SNPK*
Class# 28946 meets 02/08/2020-05/16/2020				
30190	9:00- 3:05PM	F	Rosales,I	CCHA*
Class# 30190 meets 01/17/2020-05/15/2020				
30191	8:30- 2:55PM	Sat	Nava,D	CE 6
Class# 30191 meets 01/18/2020-05/16/2020				

AED 42.11 - 0.0 UNIT SPANISH GED TEST PREP-B

Not Transferable

20002	8:30- 11:20AM	MW	Correa,R	BELL*
28941	9:00- 11:50AM	TTh	Rosales,I	LKMS*
28942	6:00- 8:50PM	MW	lachetta,C	CE 1
28943	10:30- 1:20PM	TTh	Chavez-De Vasquez,A	FISA*
28940	8:30- 2:55PM	Sat	Chavez-De Vasquez,A	CE 1
Class# 28940 meets 01/18/2020-05/16/2020				

AED 42.12 - 0.0 UNIT GED PREPARATION-A

Not Transferable

27137	6:30- 9:20PM	TTh	STAFF	CE 6
30192	8:30- 2:55PM	Sat	Morales,L	CE 7
Class# 30192 meets 01/18/2020-05/16/2020				

AED 42.13 - 0.0 UNIT GED PREPARATION-B

Not Transferable

20003	6:00- 9:25PM	MW	STAFF	CE 6
Class# 20003 meets 02/03/2020-05/20/2020				

LITERACY SKILLS FOR GENERAL EDUCATION DEVELOPMENT PREPARATION (GED)

This course is designed to provide students with additional instruction and support to pass the Reasoning Through Language Arts (RLA) subtest of the General Education Development (GED) exam. Students will learn test-taking skills, understand the official General Education Development (GED) RLA test format, and complete practice General Education Development (GED) RLA tests. All subject areas of GED will be covered

Este curso está diseñado para ofrecerle al estudiante instrucción adicional y ayudarlo a pasar el pre-examen en GED de la materia "Pensamiento crítico en el arte del lenguaje" (RLA). El estudiante tambien aprender.

AED 42.20 - 0.0 UNIT LITERACY SKILLS FOR GENERAL EDUCATION DEVELOPMENT (GED)

Not Transferable

30179	10:30- 3:20PM	M	Oviedo,A	CE 7
Class# 30179 meets 02/03/2020-05/18/2020				
30181	8:30- 1:00PM	T	Oviedo,A	SL109
Class# 30181 meets 02/04/2020-05/19/2020				
30182	10:30- 3:00PM	W	Oviedo,A	SL109
Class# 30182 meets 02/03/2020-05/20/2020				
30185	8:30- 1:00PM	Th	Oviedo,A	CE 7
Class# 30185 meets 02/06/2020-05/21/2020				

AED 42.21 - 0.0 UNIT SPANISH LITERACY SKILLS FOR GENERAL EDUCATION DEVELOPMENT (GED)

Not Transferable

30178	10:30- 3:20PM	M	lachetta,C	CE 6
Class# 30178 meets 02/03/2020-05/18/2020				
30180	8:30- 1:00PM	T	Ramos,M	SL107
Class# 30180 meets 02/04/2020-05/19/2020				
30183	10:30- 3:00PM	W	lachetta,C	CE 6
Class# 30183 meets 02/05/2020-05/20/2020				
30184	8:30- 1:00PM	Th	Ramos,M	CE 6
Class# 30184 meets 02/06/2020-05/21/2020				

SUPPLEMENTAL GENERAL EDUCATION DEVELOPMENT PREPARATION (GED MATH)

This course is for students who need additional instruction and support in order to pass the math subtest of the General Education Development (GED) exam. Students will learn test taking skills, understand the official General Education Development (GED) math test format, and complete practice. General Education Development (GED) math tests.

Esta clase es para estudiantes que necesitan una instrucción adicional y apoyo para pasar el pre-examen de matematicas del GED. Los estudiantes aprenderán las habilidades para tomar un examen, entender el examen general del GED, el formato del examen de matematicas y completar la práctica del examen de matematica en general."

AED 42.22 - 0.0 UNIT SUPPLEMENTAL GENERAL EDUCATION DEVELOPMENT (GED) MATH

Not Transferable

28898	8:30- 10:40AM	MW	Samel,C	WD 1
Class# 28898 meets 02/03/2020-05/20/2020				
30187	12:30- 2:40PM	TTh	Samel,C	CE 1
Class# 30187 meets 02/04/2020-05/21/2020				

AED 42.23 - 0.0 UNIT SPANISH SUPPLEMENTAL GENERAL EDUCATION DEVELOPMENT (GED) MATH

Not Transferable

28900	8:30- 10:40AM	MW	Morales,L	AT 54
Class# 28900 meets 02/03/2020-05/20/2020				
30186	12:30- 2:40PM	TTh	STAFF	AT 54
Class# 30186 meets 02/04/2020-05/21/2020				

Students not in attendance or late for the first class meeting are subject to drop.

Class#	Time	Day	Instructor	Room	Class#	Time	Day	Instructor	Room
--------	------	-----	------------	------	--------	------	-----	------------	------

OLDER WISER LEARNER (OWL) (FORMERLY EMERITUS COLLEGE)

The Older Wiser Learner program offers special interest, noncredit classes for adults.

These courses are designed to support lifelong learning. Register in the class. Classes are open enrollment.

El programa de aprendizaje para personas de la tercera edad ofrece clases de interés especial, sin crédito para adultos. Estos cursos están diseñados para apoyar el aprendizaje de por vida. Regístrese ahora las inscripciones están abiertas.

AED 11.08 - 0.0 UNIT STRESS MANAGEMENT/OLDER ADULT

Not Transferable

20057	1:00- 2:00PM	M	Layne,J	NSC *
	2:00- 2:50PM	M	Layne,J	NSC *
20064	3:00- 4:00PM	M	Layne,J	NSC *
	4:00- 4:50PM	M	Layne,J	NSC *
20066	1:00- 2:00PM	T	Lozano,J	DCC *
	2:00- 2:50PM	T	Lozano,J	DCC *
20068	1:00- 2:00PM	Th	Lozano,J	DCC *
	2:00- 2:50PM	Th	Lozano,J	DCC *
20070	1:00PM- 2:00PM	F	Lozano,J	DCC *
	2:00- 2:50PM	F	Lozano,J	DCC *
20072	3:00-3:30PM	TTH	Lozano,J	DCC*
	3:30- 3:50PM	TTH	Lozano,J	DCC*
20074	10:00- 10:30AM	MW	Van Herk,T	LMGM*
	10:30- 10:50AM	MW	Van Herk,T	LMGM*
20076	1:00- 2:00PM	M	Van Herk,T	CSRC*
	2:00- 2:50PM	M	Van Herk,T	CSRC *
20078	1:00- 2:00PM	W	Van Herk,T	LMGM*
	2:00-2:50PM	W	Van Herk,T	LMGM*
20080	9:45- 10:15AM	TTH	Van Herk,T	GROV*
	10:15- 10:35AM	TTH	Van Herk,T	GROV*
22952	8:15- 8:45AM	MW	Van Herk,T	NBRC*
	8:45- 9:05AM	MW	Van Herk,T	NBRC *
27354	9:00- 10:00AM	F	Van Herk,T	ACH*
	10:00- 10:50AM	F	Van Herk,T	ACH*
27356	11:15- 11:45AM	MW	Van Herk,T	LMGM*
	11:45- 12:05PM	MW	Van Herk,T	LMGM*
27358	7:30- 8:00AM	MW	Jackson,M	CSRC *
	8:00- 8:20AM	MW	Jackson,M	CSRC *
27360	9:15- 9:45AM	MW	Jackson,M	NSC *
	9:45- 10:05AM	MW	Jackson,M	NSC *
27362	10:15- 10:45AM	MW	Jackson,M	NSC*
	10:45- 11:05AM	MW	Jackson,M	NSC*
27364	5:00- 5:30PM	MW	Jackson,M	CSRC*
	5:30- 5:50PM	MW	Jackson,M	CSRC*
27366	1:00- 2:00PM	F	Jackson,M	LMAC *
	2:00- 2:50PM	F	Jackson,M	LMAC *
27370	11:00- 11:30AM	F	Van Herk,T	ACH *
	11:30-11:50AM	F	Van Herk,T	ACH *
2:00- 2:30PM		T	Van Herk,T	ACH *
	2:30-2:50PM	T	Van Herk,T	ACH *
30295	1:00- 1:30PM	MW	Jackson,M	LMAC*
	1:30- 1:50PM	MW	Jackson,M	LMAC*
30297	1:00- 1:30PM	TTh	Jackson,M	LMAC*
	1:30- 1:50PM	TTh	Jackson,M	LMAC*

AED 22.09 - 0.0 UNIT TOPICS OF INTEREST SENIORS

Not Transferable

20008	9:00- 10:50AM	F	Levy,E	NSC *
20009	12:00- 1:50PM	M	Levy,E	WDCR*
20010	12:00- 1:50PM	F	Levy,E	LMAC*
20012	10:00- 11:50AM	W	Levy,E	FOUN*
20015	1:00- 2:50PM	T	Levy,E	FOUN*
20016	1:00- 2:50PM	Th	Levy,E	FOUN*
27372	3:00- 4:50PM	M	Levy,E	CSRC*
27373	3:00- 4:50PM	Th	Levy,E	NSC *

AED 48.03 - 0.0 UNIT CREATIVE WRITING FOR SENIORS

Not Transferable

20017	2:00- 3:50PM	Th	Mansell,B	NSC *
27375	2:00- 3:50PM	T	Mansell,B	NSC *

INTRODUCTION TO ENERGY SURVEYING

AED 90.01 - 0.0 UNIT INTRODUCTION TO ENERGY SURVEYING

Not Transferable

29174	7:30- 11:30AM	MTWThF	Rosales,I	MSH *
	11:30- 3:30PM	MTWThF	Rosales,I	MSH *
Class# 29174 meets 01/13/2020-01/17/2020				

BASIC ELECTRICITY AND WIRING FUNDAMENTALS

AED 90.02 - 0.0 UNIT BASIC ELECTRICITY AND WIRING FUNDAMENTALS

Not Transferable

29170	7:30- 11:30AM	MTWThF	Rosales,I	MSH *
	11:30- 3:30PM	MTWThF	Rosales,I	MSH *
Class# 29170 meets 01/21/2020-01/25/2020				

INTRODUCTION TO LIGHTING RETROFITS

AED 90.03 - 0.0 UNIT INTRO TO LIGHTING RETROFITS

Not Transferable

29172	7:30- 11:30AM	MTWThF	Rosales,I	MSH *
	11:30- 3:30PM	MTWThF	Rosales,I	MSH *
Class# 29172 meets 01/27/2020-01/31/2020				

INTRODUCTION TO AUTOMOTIVE TOOLS AND EQUIPMENT

This course is focused on entry level jobs in the Automotive Industry.

Este curso está enfocado en trabajos de nivel de entrada en la industria automotriz.

AED 90.04 - 0.0 UNIT INTRODUCTION TO AUTOMOTIVE TOOLS AND EQUIPMENT

Not Transferable

30218	8:30- 11:50AM	Sat	Vasilik,R	AT 54
Class# 30218 meets 01/18/2020-05/16/2020				
30219	11:50- 2:55PM	Sat	Vasilik,R	AT 54
Class# 30219 meets 01/18/2020-05/16/2020				

Students not in attendance or late for the first class meeting are subject to drop.

Class#	Time	Day	Instructor	Room	Class#	Time	Day	Instructor	Room
--------	------	-----	------------	------	--------	------	-----	------------	------

MATH SUPPORT: STATISTICS

This course will provide additional support for Introductory Statistics. This course is for students who desire greater self-confidence and wish to improve math skills. Students will develop a range of knowledge in pre-statistics. Students will gain conceptual knowledge and use analytical thinking to solve problems. The combination lecture/lab format will provide a foundation for introductory statistics. Recommended non-credit support for Math 75 or Math 112. This course is open entry/open exit.

Esta clase provee soporte adicional para la clase introductoria de estadísticas. La clase es para estudiantes que buscan mejorar sus habilidades en matemáticas y quieren ese soporte extra para clase. Los estudiantes que atiendan desarrollaran un rango de habilidades en estadísticas. Conceptos de análisis crítico y solución de problemas. Formato de lectura con laboratorio provee a una fundación para las clases de introducción a estadísticas. Recomendado clase sin crédito para Math 75 o Math 112. Esta clase es de inscripción abierta.

AED 90.06 - 0.0 UNIT MATH SUPPORT: STATISTICS

Not Transferable

30225	11:00- 12:30PM	MW	Ortiz,L	MP103
	12:30- 1:50PM	MW	Ortiz,L	MP103
	Class# 30225 meets 02/03/2020-05/20/2020			
30227	1:00- 2:30PM	MW	Ortiz,L	MP105
	2:30- 3:50PM	MW	Ortiz,L	MP105
	Class# 30227 meets 02/03/2020-05/20/2020			
30229	2:30- 4:00PM	TTh	Ortiz,L	MP104
	4:00- 5:20PM	TTh	Ortiz,L	MP104
	Class# 30229 meets 02/04/2020-05/21/2020			
30231	4:30- 6:00PM	TTh	Ortiz,L	MP105
	6:00- 7:20PM	TTh	Ortiz,L	MP105
	Class# 30231 meets 02/04/2020-05/21/2020			
30233	10:00- 11:30AM	TTh	Carino,J	MP105
	11:30- 12:50PM	TTh	Carino,J	MP105
	Class# 30233 meets 02/04/2020-05/21/2020			
30235	1:00- 2:30PM	TTh	Carino,J	MP105
	2:30- 3:50PM	TTh	Carino,J	MP105
	Class# 30235 meets 02/04/2020-05/21/2020			
30237	5:30- 7:00PM	TTh	Carino,J	MP104
	7:00- 8:20PM	TTh	Carino,J	MP104
	Class# 30237 meets 02/04/2020-05/21/2020			
30267	1:00- 12:30PM	MW	Ortiz,L	TBA*
	12:30- 1:50PM	MW	Ortiz,L	TBA*
	Class# 30267 meets 02/03/2020-05/20/2020			
30269	12:00- 1:30PM	MW	Ortiz,L	TBA*
	1:30- 2:50PM	MW	Ortiz,L	TBA*
	Class# 30269 meets 02/03/2020-05/20/2020			
30271	1:00- 2:30PM	MW	Ortiz,L	TBA*
	2:30- 3:50PM	MW	Ortiz,L	TBA*
	Class# 30271 meets 02/03/2020-05/20/2020			
30273	2:00- 3:30PM	MW	Ortiz,L	TBA*
	3:30- 4:50PM	MW	Ortiz,L	TBA*
	Class# 30273 meets 02/03/2020-05/20/2020			
30275	10:00- 1:30PM	W	Ortiz,L	TBA*
	1:30- 3:50PM	W	Ortiz,L	TBA*
	Class# 30275 meets 02/05/2020-05/20/2020			
30277	10:00- 1:30PM	Th	Carino,J	TBA*
	1:30- 3:50PM	Th	Carino,J	TBA*
	Class# 30277 meets 02/06/2020-05/21/2020			

MATH SUPPORT: COLLEGE ALGEBRA

This course is a math support course. This course is for students who desire greater self-confidence and wish to improve their algebra skills. Students will build pre - college level math skills to prepare for college algebra. Students will gain conceptual knowledge and use analytical thinking to solve problems. The combination lecture/lab format will provide a foundation for college algebra. Recommended non-credit support for Math 60, Math 80, or Math 114. This course is open entry/open exit.

Esta es una clase de soporte para matemáticas. El curso está diseñado para estudiantes que quieran adquirir confianza en sus habilidades y deseen mejorar sus habilidades en algebra. Estudiantes obtendrá las habilidades necesarias para pre algebra para estar listo para algebra en el colegio. Estudiantes aprenderán conceptos de análisis y como resolver problemas. Recomendado clase de soporte sin credito para Math 60, Math 80 o Math 114.

AED 90.07 - 0.0 UNIT MATH SUPPORT: COLLEGE ALGEBRA

Not Transferable

30239	10:00- 11:30AM	MW	Takeuchi,K	MP105
	11:30- 12:50PM	MW	Takeuchi,K	MP105
	Class# 30239 meets 02/03/2020-05/20/2020			
30241	10:00- 11:30AM	TTh	Ortiz,L	MP104
	11:30- 12:50PM	TTh	Ortiz,L	MP104
	Class# 30241 meets 02/04/2020-05/21/2020			
30243	12:00- 1:30PM	TTh	Ortiz,L	CE 2
	1:30- 2:50PM	TTh	Ortiz,L	CE 2
	Class# 30243 meets 02/04/2020-05/21/2020			
30245	5:30- 7:00PM	TTh	Ortiz,L	WD 1
	7:00- 8:20PM	TTh	Ortiz,L	WD 1
	Class# 30245 meets 02/04/2020-05/21/2020			
30247	9:00- 12:20PM	Sat	Carino,J	MP104
	12:20- 2:20PM	Sat	Carino,J	MP104
	Class# 30247 meets 01/18/2020-05/16/2020			
30249	9:00- 10:30AM	MW	Ortiz,L	CE 2
	10:30- 11:50AM	MW	Ortiz,L	CE 2
	Class# 30249 meets 02/03/2020-05/20/2020			
30251	12:00- 1:30PM	MW	Takeuchi,K	CE 2
	1:30- 2:50PM	MW	Takeuchi,K	CE 2
	Class# 30251 meets 02/03/2020-05/20/2020			

Students not in attendance or late for the first class meeting are subject to drop.

Site Locations

SITE	NAME	LOCATION
ABBS*	Albert Baxter Elementary Schoo	14929 Cerritos Ave, Bellflower
AGMC*	Anaheim Global Medical Center	1025 S Anaheim Blvd, Anaheim
ARMC*	Anaheim Regional Medical Cente	111 W. La Palma Ave., Anaheim
ACH *	Artesia Christian Hospital	11614 E. 183rd St., Artesia
AHS *	Artesia High School	12108 Del Amo Blvd, Lakewood
BELL *	Bellflower - Washington Elemen	9725 Jefferson St, Bellflower
BELF*	Bellflower High School	15301 McNab Ave, Bellflower
CGLB*	Casa Guerrero	672 Temple Ave, Long Beach
CCHA*	Centro CHA Incorporated	1633 Long Beach Blvd, Long Beach
CERR*	Cerritos High School	12500 183rd St, Cerritos
CDCL*	Children's Dental Clinic	300 East Buckthorn, Inglewood
CPH *	Coast Plaza Hospital, Norwalk	13100 Studebaker Road, Norwalk
CH *	College Hospital	10802 College Pl., Cerritos
DAS *	Downey Adult School	12340 Woodruff Ave, Downey
ELMT*	El Monte Dental Clinic	10953 Romona Blvd., El Monte
FISA*	Fedde International Studies Ac	21409 S. Elaine Ave., Hawaiian Gardens
HDSN*	Hudson Dental Clinic	2829 South Grand Ave., Los Angeles
HMPH*	Humphrey Dental Clinic	5850 S. Main St., Los Angeles
KDMC*	Kaiser Downey Medical Center	9333 Imperial Hwy., Downey
LCMC*	La Casa Mental Health Rehab Ct	6060 Paramount Blvd., Long Beach
LM20*	La Mirada Adult Center Room 20	15310 Alondra Blvd., La Mirada
LM34*	La Mirada Adult Center Room 34	15310 Alondra Blvd., La Mirada
LKMS*	Lakeland Middle School	11224 Bombardier Ave., Norwalk
LRMC*	Lakewood Regional Medical Cent	3700 E. South St., Lakewood
LBHC*	Long Beach Comprehensive Healt	1333 Chestnut Ave, Long Beach
LBVA*	Long Beach Veteran's Admin	5901 E. 7th St., Long Beach
LAH *	Los Alamitos Hospital	3751 Katella Ave., Los Alamitos
MLK *	Martin Luther King, Jr. Outpat	1670 E 120th St, Los Angeles
MSH *	Metropolitan State Hospital	11401 Bloomfield Ave, Norwalk
MESP*	Migrant Ed. Student/Parent Ctr	2215 Elaine Ave., Hawaiian Gardens
NOR *	Northgate Store	Contact department for location
COCC*	One-Stop Career Center Plus	10900 E. 183rd St., Suite 392, Cerritos
PADL*	Padelford Park	16912 Clarkdale Ave. Artesia
PIHD*	PIH HEALTH-DOWNEY	11500 Brookshire Ave, Downey
PIHW*	PIH HEALTH-WHITTIER	12401 Washington Blvd, Whittier
RLA *	Rancho Los Amigos	7601 E. Imperial Hwy., Downey
RYBL*	Roybal Dental Clinic	2345 S. Fetterly Ave., Los Angeles
SOHS*	Somerset High School	9242 Laurel St, Bellflower
SNPK*	Spane Park	14400 Gundry Ave, Paramount
TMJF*	Thomas Jefferson Elem. School	10027 Rose St., Bellflower
TBD *	To Be Determined	
USC *	University of Southern Califor	925 W. 34th, Los Angeles
VECH*	Villa Elena	13226 Studebaker Rd. Norwalk
WARR*	Warren High School	8141 De Palma St, Downey

APPRENTICESHIP PROGRAMS

Learn a trade while you work. Apprenticeship is a well-organized and supervised method of training individuals who have little or no knowledge of the craft.

- Cerritos College has 3 apprenticeship programs:
- Field Ironworkers
 - SC/PDCA Painters & Decorators of California
 - CAFSA-California American Fire Sprinkler Association

For further information call (562) 860-2451, ext. 2497

Aprende un oficio mientras trabajas. Este programa de aprendizaje está bien organizado y supervisado para capacitar a personas que tienen poco o nada de conocimiento en el oficio.

FOSTER KINSHIP CARE PROGRAM

The workshops offered through Cerritos College help to enhance and develop parenting skills related to caring for both foster children and children in a relatives care. As a licensed foster parent, you are required to obtain continuing education hours every year, and the classes we offer at Cerritos College through the FKCE program fill these requirements.

For further information call (562) 860-2451, ext. 2548

Los talleres ofrecidos por medio del colegio de Cerritos es para mejorar y desarrollar las habilidades de los padres relacionados al cuidado de ambos, tanto padres como hijos de crianza. Usted como padre de crianza con licencia, le es requerido recibir un número de horas de entrenamiento cada año. Las clases que ofrecemos a través del colegio de Cerritos le ayudarán a completar este requisito.

PLAZA COMMUNITARIA

The Office of Adult Education & Diversity Programs in collaboration with the Mexican Consulate in Los Angeles offers an innovative new program called Plaza Comunitaria. The program consists of three levels of progression which teach the Spanish speaking adults to read, write and speak in their native tongue and to complete their first and secondary education. At the completion of this program the student will receive a diploma from the Secretary of Public Education from Mexico. Our goal is to transition the student into regular ESL courses with a higher rate of success and then introduce them to a higher level of education.

For further information call (562) 860-2451, ext. 2518

El Departamento de Educación de Adultos y Programas Diversos en colaboración con el Consulado Mexicano de Los Ángeles ofrecemos un nuevo e innovador programa "Plaza Comunitaria." La Plaza Comunitaria es un programa que consiste tres niveles que permite que los adultos de habla Español aprendan a leer y escribir en su lengua natal y acabar su educación primaria y secundaria. Al terminar cada nivel, el estudiante recibe un diploma de la Secretaría de Educación Pública en México. Al terminar su educación secundaria los estudiantes son capaces a la transición en cursos de ESL con un índice mas alto de éxito.



CHICANO STUDIES

WHY STUDY CHICANO STUDIES?

The Mexican American/Chicano(a)/Latinx Department seeks to increase critical understanding and appreciation of social, historical, and continuing cultural significance of Mexican American and Latinx communities. The Latinx population has played an important role in shaping our nation's history and is now the fastest growing population in the United States, and will soon become the majority population in the state of California. Students who major in Chicano Studies will enroll in classes from a variety of disciplines that enrich their understanding of the experiences and contributions of Mexican Americans and Latino[a]s past and present. The Chicano Studies Associate in Arts Degree requires completion of courses from the fields of History, Art, Women's Studies, Sociology, Philosophy, Psychology, Spanish, English, and Anthropology.

Chicano Studies courses are vital to help you learn, value, and practice cultural competence – an imperative and beneficial skill to build in an increasingly diverse society. Chicano Studies courses will help you gain more self-confidence and improved self-esteem to experience new ways of learning, as course framework reflects that of historically marginalized groups that are often overlooked.

IF YOU TAKE COURSES IN CHICANO STUDIES, YOU WILL:

- Gain understanding of the importance of Chicano(a)/ Latinx culture in the United States.
- Analyze and evaluate the contributions of Chicano(a)s and Latinx within US society in diverse disciplines such as Politics, Science, Health, Education, Social Sciences, Humanities, Music, and Fine Arts.
- Be introduced to significant Mexican American, Chicano, and Latino leaders in the US, both new and contemporary figures, as a form of mentorship. Learning about these leaders will help you advance further in your personal, academic, and professional lives.
- Become active in today's society to procure benefits for your education and for the benefit of others in your community.

The Associate in Arts Degree in Chicano Studies prepares students to transfer to California State University (CSU) campuses that offer Chicano Studies. In addition, Chicano Studies is an interdisciplinary program that contains a wide array of classes from English, Spanish, History, Social Science, Fine Arts, Women Studies, and Anthropology. All of these major courses of study will also prepare the student to obtain additional coursework to major and/or minor in the disciplines mentioned above. The degree requires students to complete 60 CSU transferable units.

There are many careers in which a Chicano Studies degree is beneficial:

- Arts, Fine Arts, & Music
- Community Organizing
- English
- Foreign Service
- Journalism
- Marketing & Public Relations
- Medical Profession
- Public & Business Administration
- Law
- Law Enforcement
- Librarian/Historian
- Non-Profit Organization
- Public Policy
- Social Work
- Teaching: K-12, Credentialing, & Higher Education

MAJOR REQUIREMENTS:

Required Courses	(19 units)	Elective Courses (choose two courses)	(6–9 units)
ENGL 223 Chicana/Chicano Literature	3.0	ANTH 100 Cultural Anthropology	3.0
ENGL 225 Mexican Literature in Translation	3.0	ANTH 170 Introduction to Language and Culture	3.0
SPAN 101 Elementary Spanish	3.0	ANTH 202 The Mayans, Incans, and Aztecs: Ancient Civilizations of the Americas	3.0
or SPAN 111 Elementary Spanish for Spanish Speakers	(5.0)	ART 105A The Arts of Latin America and the Caribbean: Pre-Colombian	3.0
SPAN 102 Elementary Spanish	5.0	ART 105B The Arts of Latin America and the Caribbean: Colonial to the Present	3.0
or SPAN 112 Elementary Spanish for Spanish Speakers	(5.0)	COUN 150 Dynamics of Leadership	3.0
SPAN 245 Introduction to Chicano/Mexican American Culture	5.0	HIST 120 History of California	3.0
		HIST 230 History of Mexico	3.0
		HIST 235 History of Latin America	3.0
		HO 100 Health of Underserved Communities	3.0
		HUM 108 Black Images in Popular Culture	3.0
		or ART 108 Black Images in Popular Culture	(3.0)
		INST 100 Principles and Strategies for Problem Solving	3.0
		PHIL 104 Philosophy of Cultural Diversity: Challenge and Change	3.0
		PHIL 200 World Religions	3.0
		PSYC 261 Social Psychology	3.0
		SOC 201 Social Problems	3.0
		SOC 215 Sociology of Cultural Diversity, Challenge and Change	3.0
		SOC 210 American Minority Relations	3.0
		SPAN 201 Intermediate Spanish	5.0
		SPAN 202 Intermediate Spanish	4.0
		SPAN 210 Highlights of Hispanic Culture	3.0
		WGS 101 Issues for Women in American Society	3.0
		WGS 105 Gender Studies and the Chicana/Latina Experience	3.0

ASSOCIATE IN ARTS DEGREE REQUIREMENTS: Complete the following (1) major requirements, (2) the A.A. Degree General Education requirements, and (3) electives to achieve a minimum of 60 units.

	AA	CSU	IGETC
Major Total:	25-28 units	25-28 units	25-28 units
GE Pattern: AA, CSU, and IGETC:	18 units	18 units	37 units
Double Counted Units:	0	12	18
Degree applicable electives (as needed): (CSU and IGETC requires CSU transferable units)	42 units	5-7 units	13-16 units
Total Degree Units (Maximum):	60 units	60 units	60 units

Total Major Requirements:

25 – 28



SCHOLARS' HONORS PROGRAM

WHAT IS THE SCHOLARS' HONORS PROGRAM?

The Scholars' Honors Program (SHP) is a social and academic home that Cerritos College offers to talented and motivated students planning to transfer to four-year colleges and universities, especially to the UC and CSU systems. It introduces you to a community of faculty and staff who are committed to helping you succeed, and it provides you with a supportive environment of fellow students with similar goals and interests.

AM I ELIGIBLE FOR THE SHP?

- A cumulative GPA of 3.0 in all coursework
- Readiness for English 100 (Freshman Composition)

HOW DO I JOIN?

Go online to the SHP web page, <http://www.cerritos.edu/shp>.

HONORS COURSES, SPRING SESSION, 2020

Communications 110:	Intercultural Communication Prof. Angela Hoppe-Nagao, ONLINE (1st 9 weeks) Prof. Angela Hoppe-Nagao, ONLINE (2nd 9 weeks) UC/CSU: Fulfills an IGETC Social & Behavioral Sciences requirement (Plan C: Area 4)	Class #29940 Class #29941
Art 108: or Humanities 108	Black Images in Popular Culture Prof. Julie Trager, TuTh 3:30—6:20 pm (1st 9 weeks) UC/CSU: Fulfills an IGETC Arts & Humanities requirement (Plan C: Area 3A OR Area 3B)	Class #28181 Class #28182
Earth Science 104:	Oceanography Prof. Dan DeKraker, Tu 12:30—3:20 pm UC/CSU: Fulfills an IGETC Physical & Biological Sciences requirement (Plan C: Area 5A)	Class #20404
Economics 202M:	Principles of Microeconomics Prof. Solomon Namala, TuTh 8:30 am—10:40 am (15 weeks) UC/CSU: Fulfills an IGETC Social & Behavioral Sciences requirement (Plan C: Area 4)	Class #22592
English 100:	Freshman Composition Prof. Timothy Juntilla, MW 7:00—8:50 am Prof. Timothy Juntilla, MW 9:00—10:50 am UC/CSU: Fulfills the IGETC Freshman Composition requirement (Plan C: Area 1A)	Class #20365 Class #25831
English 103:	Critical and Argumentative Writing Prof. Daniel Gardner, MW 8:00—9:15 am UC/CSU: Fulfills the IGETC Critical Thinking requirement (Plan C: Area 1B)	Class #20868
English 110:	Critical Thinking Through Literature Prof. Niki Lovejoy-Robold, ONLINE (15 weeks) UC/CSU: Fulfills the IGETC Critical Thinking requirement (Plan C: Area 1B)	Class #29869
Humanities 107:	Men & Masculinities: Constructing Manhood in America Prof. Julie Trager, MW 11:00 am—1:50 pm (1st 9 weeks) UC/CSU: Fulfills an IGETC Social & Behavioral Sciences requirement (Plan C: Area 4)	Class #29718
Psychology 210:	Elementary Statistics Prof. Jaclyn Ronquillo-Adachi, TuTh 8:00—10:50 am UC/CSU: Fulfills an IGETC Mathematical Concepts & Quan. Reasoning requirement (Plan C: Area 2)	Class #20689
Sociology 101:	Introduction to Sociology Principles Prof. Amy Holzgang, MW 12:30—2:00 pm (15 weeks) UC/CSU: Fulfills an IGETC Social & Behavioral Sciences requirement (Plan C: Area 4)	Class #25771
Sociology 205:	Introduction to Social Research Methods Prof. Amy Holzgang, TuTh 9:30—11:00 am (15 weeks) UC/CSU: Fulfills an IGETC Social & Behavioral Sciences requirement (Plan C: Area 4)	Class #22304

WOMEN'S AND GENDER STUDIES DEPARTMENT

SPRING 2020 CLASSES

Schedule in subject to change. For more information please contact,
Amy Holzgang and Michelle Fagundes, Co-Chairs, Women's and Gender Studies Department.

"Gender equality is a shared vision of social justice and human rights"
United Nations' Women Executive Director Phumzile Mlambo-Ngcuka

"Culture does not make people. People make culture. If it is true that the
full humanity of women is not our culture, then we can and must make it our culture."

Chimamanda Ngozi Adichie, (Nigerian author, awarded a MacArthur
Genius Grant in 2018 and author of *We Should All Be Feminists*, 2015.)

Women's and Gender Studies 101 (WGS 101) *Issues for Women in American Society*

Transferable to UC and CSU.

Class #22876 Michelle Fagundes M/W 12:30 – 1:45 pm
Class #21045 Staff M/W 5:00 – 6:15 pm

Women's and Gender Studies 102 (WGS 102) *Women and Religion*

Transferable to UC and CSU.

Class #22442 Mariam Youssef T/TH 2:00 – 3:15 pm

Women's and Gender Studies 103 (WGS 103) *Women, their Bodies and Health*

Transferable to UC and CSU.

Class #21856 Staff M/W 9:30 – 10:45 am
Nine Week Session B7 T/TH Session (3/24/2020 - 5/21/2020)
Class #23707 Staff T/TH 6:30 – 9:20 pm

Women's and Gender Studies 104 (WGS 104) *Community Organizing and Activism*

Transferable to UC and CSU

Class #29711 Heather St. John T/TH 2 – 3:15 pm

Women's and Gender Studies 108 (WGS 108) *Women in Sports*

Transferable to CSU.

Class #25696 Trisha Kozlowski ONLINE

Nine Week Session B M-F Session (3/23/2020 - 5/22/2020)

Class #28137 Trisha Kozlowski ONLINE



Women's and Gender Studies 109 (WGS 109) *Philosophy of the Body, Feminism and Gender*

Transferable to CSU.

Class #27312 Matthew Mayock T/TH 2:00 – 3:15 pm

Women's and Gender Studies 115 (WGS 115) *Gender, Communication, and the Digital Revolution*

Transferable to UC and CSU.

Fifteen Week Session B7 T/TH Session (2/4/2020 - 5/21/2020)

Class #29713 Kimberly Rosenfeld T/TH 9:30 – 11:00 am

Nine Week Session A M-F Session (1/13/2020 - 3/13/2020)

Class #29712 Kimberly Rosenfeld ONLINE

Nine Week Session B M-F Session (3/23/2020 - 5/22/2020)

Class #28777 Kimberly Rosenfeld ONLINE

Women's and Gender Studies 202 (WGS 202) *Gender and Society*

Transferable to UC and CSU.

Class #29065 Staff M/W 7:00 – 9:50 pm

Fifteen Week Session B6 M/W (2/3/2020 - 5/20/2020)

Class #28122 Amy Holzgang M/W 2:00 – 3:30 pm Honors

Fifteen Week Session B7 T/TH (2/4/2020 - 5/21/2020)

Class #27065 Amy Holzgang T/TH 12:30 - 2:00 pm

Women's and Gender Studies 205 (WGS 205) *Anthropology of Sex and Gender*

Transferable to UC and CSU.

Class #27066 Staff M/W 12:30 – 1:45 pm

Women's and Gender Studies 208 (WGS 208) *Leadership for Women in Business*

Transferable to CSU. All class information will be available at
www.cerritos.edu/baonline.

Fifteen Week Session A M-F (1/13/2020 - 5/1/2020)

Class #24196 Barbara Livingston ONLINE

Nine Week Session A M-F Session (1/13/2020 - 3/13/2020)

Class #27063 Barbara Livingston ONLINE

Nine Week Session B M-F Session (3/23/2020 - 5/22/2020)

Class #29030 Barbara Livingston ONLINE

Women's and Gender Studies 250 (WGS 250) *Foundation of Feminist, Gender and Queer Theories*

Transferable to UC and CSU

Class #28778 Mariam Youssef T/TH 5:30 – 6:45 pm

LEARNING COMMUNITIES

For Spring 2020, there are two Learning Communities: Puente Program and Umoja Success Program.

For more information about enrolling in the Learning Communities Program or for a complete description of each learning community, please check the website at www.cerritos.edu/lcp/ or call (562) 860-2451, ext. 2212.

PUENTE PROGRAM:

The Puente Program is designed to help students achieve academic success, instills a sense of belonging, and guarantees students four transfer courses with textbooks provided at no cost. These courses are all transferrable and will get you more familiar with the transfer process, major and career decision process, and build your leadership skills. The most unique aspect of the Puente Program is that the professors approach these four subjects through a Latina/o perspective, including Latina/o authors; historical and contemporary issues in the Latinx community; and different themes pertaining to the Latina/o community.

Through Puente you will receive counseling, guidance, mentorship, and assistance on the importance of transferring into a CSU, UC, or Private Universities. The Puente Program also takes students on field trips such as visiting Northern California universities free of charge.

For more information on the Puente Program, contact the Counseling Department at (562) 467-5231.

23158	COUN 150	3 units	Romero, G.	TTH	12:30 – 1:45 pm	BC 47
29011	ENGL 103	3 units	Quaas-Berryman, F.	TTH	9:00 – 10:15 am	MCIS 211
Total Units:		6 units				

UMOJA SUCCESS PROGRAM:

Be a part of a community of scholars designed with you in mind! The Umoja Success Program was designed to assist Black, African, African American students, and others in achieving academic and life success through the exploration of Black Culture and Hip Hop. A dynamic learning experience shared by a group of students with faculty that is committed to their success. Umoja is a place to call home!

So what's in it for you? Academic and personal support, academic and cultural excursions, helpful resources, and so much more. For more information about the Umoja Success Program and joining our community, please contact the Counseling Department at (562) 467-5231.

If you want to go fast, then go alone. If you're going to go far, go together! —UMOJA!

26377	COUN 150	3 units	Hill, S.	TTH	12:30 – 1:45 pm	LA 203
30286	ENGL 103	3 units	Cagnolatti, D.	MW	1:00 – 2:15 pm	MP 211
Total Units:		6 units				

LEARNING COMMUNITIES CLASSES

Learning communities involve the intentional creation of class pairs or clusters around a common theme, public issue, or question. Typically, the same group of students is co-enrolled in two or more courses, usually from different disciplines—for instance, English and career guidance. Students enroll in both courses but receive a separate grade for each one. Classroom activities, tests, assignments, field trips, research projects, and educational technology are used to engage students in their own learning, as well as provide them with valuable “real-world” skills. Students enroll in both courses but receive a separate grade for each one.

Perhaps more importantly, the learning community model promotes student-centered learning, with an emphasis on an enriched classroom environment. It promotes greater intellectual growth and genuine mastery of course content through collaborative activities, frequent feedback, and increased student-teacher and student-student interactions.

Research indicates learning communities promote student achievement, retention, and progress toward degree completion. Faculty benefit from professional development and training, fresh approaches to teaching, and collaboration with colleagues.

WHAT ARE THE BENEFITS OF JOINING A LEARNING COMMUNITY?

- Smooth your transition into college
- Meet other students and form lasting friendships
- Learn how to choose your major and reach your academic goals sooner
- Graduate or transfer to a four-year college or university sooner
- Increase your learning and earn better grades

ARE LEARNING COMMUNITY COURSES TRANSFERABLE?

Many of the courses are transferable to CSUs and/or UCs. See the Schedule of Classes, the Cerritos College Catalog, or meet with a counselor to check specific courses.

WHAT ARE THE REQUIREMENTS TO ENROLL?

The only requirements to enroll in a Learning Community are that you:

- a) meet the prerequisites for all courses and
- b) enroll in all courses listed for that Learning Community.

The prerequisites are listed in the Cerritos College Catalog and must be met prior to enrollment.

HOW WILL LEARNING COMMUNITY COURSES BE LISTED ON MY TRANSCRIPT?

Your transcript will reflect the classes as separate courses.

QUESTIONS

If you have questions about the Learning Communities Program (LCP), please call (562) 860-2451, ext. 2782, or stop by the LCP Center located in the Multipurpose Building, room MP 100 A-E.

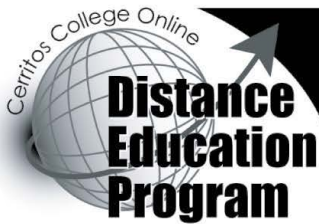

DISTANCE EDUCATION PROGRAM ONLINE COURSES

For complete course descriptions, see the regular course listings in the schedule of classes.

WHAT IS DISTANCE EDUCATION?

Distance Education takes place when a teacher and students are separated by physical distance. In place of traditional classroom delivery; voice, video, data, and print are used to bridge the instructional gap. Cerritos College offers online and hybrid courses (see definitions in next column). All courses carry full academic credit and their content is equivalent to what you would receive in a more traditional mode of delivery.

WHAT SKILLS ARE REQUIRED FOR ONLINE LEARNING?

In order to support student success in online classes, students and faculty should be aware of core skills and expectations that promote student achievement in an online learning environment. For students who are interested in taking an online class for the first time, please refer to the Student Success Center in the LRC for assistance, or contact the instructor of the course directly. Students should consider taking a one-unit course: EDT 50: Preparation for Online Learning.

Necessary Student Skills:

1. Basic Computer skills (send and receive email and attachments; download files; fundamentals of file management; search and navigate the Internet using a browser)
2. Awareness of institutional support services (Student Success Centers)
3. Successful completion of prerequisite coursework
4. Organizational skills
5. Reading comprehension
6. Writing skills
7. Communication skills
8. Time-management skills
9. Proficiency in any adaptive computing software/hardware needed to access the online course material when there is a disability-related barrier
10. Recommended completion of online orientation (such as EDT 50) or equivalent preparation
11. Familiarity with college course management system (such as Canvas)

Student Learning Expectations:

1. Motivated and focused
2. Awareness of online expectations, environment and workload
3. Autonomous, self-motivated learner
4. Positive attitude toward technology
5. Intention to complete the course
6. Ability to work independently
7. Ability to work as a group member
8. Having the confidence to follow directions and to ask for assistance

Before registering for any online course, you should make sure that you have proficient skills in basic computing, web browsing, email, and word processing. Your instructor will not teach these skills as part of the course content. If you do not possess these skills, you may want to enroll in EDT 50: Preparation for Online Learning, or CIS 50: Basic Computer Literacy.

WHAT ARE THE TYPES OF ONLINE INSTRUCTION?

Online courses occur online. Some instructors may require on-campus attendance for orientation, test-taking, or to satisfy other course requirements. Access to email and the Internet are required to complete work using email, chat rooms, discussion boards, and other instructional tools. Online courses are designated as OL in the published class schedule.

Hybrid courses include the combination of traditional in-class instruction with online instruction. Therefore, students will be required to attend on-campus meetings as scheduled by the instructor, as well as complete work using email, the campus course management system (Canvas) and/or chat rooms, discussion boards, and other instructional tools. These courses are designated as HYBRID in the published class schedule.

ENROLLING IN AN ONLINE COURSE?

Students enroll in online sections in the same manner as regular classes. Consult the general enrollment procedures in this schedule for more information.

ACCESSING ONLINE AND HYBRID COURSES:

Once you are enrolled in a class, go to the Canvas website, www.cerritos.edu/canvas, and log on with your username and password.

Username: This is your 7-digit student ID number. Example: John Smith, ID #1234567. Your ID number, 1234567, is your username.

Password: Your initial password is your 8-digit date of birth in the "mmddyyyy" format. Example: John Smith's date of birth is May 30, 1990. His password would be 05301990.

ONLINE ORIENTATION:

There is also an online general orientation for all online courses. Go to www.cerritos.edu/de. Some instructors give on-campus orientations. Check course listings for information. **You must attend any mandatory orientations and/or contact your instructor prior to the 1st week of class or you may be dropped.** If the orientation for an online class conflicts with a class that meets on campus, you must attend the on-campus class and notify the online instructor about the conflict in advance.

FOR INFORMATION CONTACT THE SUCCESS CENTER

Phone: (562) 860-2451, x2404 or (562) 653-7891

Email: de-info@cerritos.edu or visit the DE home page at: <http://www.cerritos.edu/de>

DISTANCE EDUCATION COURSES

ONLINE COURSES

Most work and communications occur online. Access to email and the Internet is required. Orientations are mandatory.

ACCOUNTING

28083	ACCT 61	Turbo Tax Accounting
22733	ACCT 61	Turbo Tax Accounting
22020	ACCT 100	Introduction to Accounting
23465	ACCT 100	Introduction to Accounting
23467	ACCT 100	Introduction to Accounting
22049	ACCT 133	Spreadsheet Accounting I
22047	ACCT 133	Spreadsheet Accounting I
28085	ACCT 220	Accounting Ethics
29686	ACCT 251	Advanced Income Tax Accounting
28768	ACCT 280	Advanced Accounting

ADMINISTRATION OF JUSTICE

20186	AJ 101	Introduction to Administration of Justice
20191	AJ 105	Community Relations and Cultural Awareness
28100	AJ 222	Juvenile Procedures

ANTHROPOLOGY

26392	ANTH 115	Physical Anthropology
29690	ANTH 115	Physical Anthropology

ARCHITECTURE

30114	ARCH 110	Introduction to Architecture and Environmental Design
30001	ARCH 112	History of Architecture

ART AND DESIGN

21778	ART 100	Introduction to World Art
20205	ART 101	Art History I: Prehistory to Gothic
22878	ART 102	Art History II: Renaissance to Rococo
28725	ART 107	Asian Art History
20234	ART 192	Photoshop/Digital Imaging
21204	ART 192	Photoshop/Digital Imaging
26987	ART 192	Photoshop/Digital Imaging
26988	ART 192	Photoshop/Digital Imaging

ASTRONOMY

22205	ASTR 103	Introductory Astronomy: The Solar System
22427	ASTR 103	Introductory Astronomy: The Solar System
22601	ASTR 103	Introductory Astronomy: The Solar System
29674	ASTR 106	History of Astronomy

BUSINESS ADMINISTRATION

24203	BA 100	Fundamentals of Business
22004	BA 100	Fundamentals of Business
27262	BA 100	Fundamentals of Business
27263	BA 100	Fundamentals of Business
23913	BA 100	Fundamentals of Business
26855	BA 100	Fundamentals of Business
22541	BA 101	International Business
20816	BA 101	International Business
21760	BA 104	Managing Cultural Diversity
27218	BA 104	Managing Cultural Diversity
29026	BA 104	Managing Cultural Diversity
22603	BA 106	Human Resource Management

22364	BA 106	Human Resource Management
27314	BA 106	Human Resource Management
23896	BA 106	Human Resource Management
26159	BA 106	Human Resource Management
26708	BA 106	Human Resource Management
29159	BA 106	Human Resource Management
29213	BA 106	Human Resource Management
29691	BA 106	Human Resource Management
23033	BA 107	Human Relations In Business
23777	BA 107	Human Relations In Business
26711	BA 107	Human Relations In Business
26857	BA 107	Human Relations In Business
27316	BA 107	Human Relations In Business
28497	BA 107	Human Relations In Business
29184	BA 107	Human Relations In Business
28246	BA 108	Labor Management Relations
29160	BA 108	Labor Management Relations
27264	BA 109	Human Resource Development
29161	BA 109	Human Resource Development
27004	BA 110	Advertising
27732	BA 110	Advertising
21759	BA 113	Legal Environment of Business
23914	BA 113	Legal Environment of Business
22000	BA 113	Legal Environment of Business
27424	BA 113	Legal Environment of Business
27425	BA 113	Legal Environment of Business
27456	BA 113	Legal Environment of Business
29027	BA 113	Legal Environment of Business
20253	BA 114	Marketing
23015	BA 114	Marketing
26677	BA 114	Marketing
27733	BA 114	Marketing
21996	BA 114	Marketing
26675	BA 114	Marketing
26719	BA 114	Marketing
29028	BA 114	Marketing
22007	BA 115	Management-Business
20817	BA 115	Management-Business
23036	BA 115	Management-Business
26161	BA 115	Management-Business
26325	BA 115	Management-Business
28090	BA 115	Management-Business
27318	BA 117	Introduction to Supervision
23479	BA 118	Retail Management
28283	BA 118	Retail Management
23478	BA 118	Retail Management
22865	BA 118	Retail Management
26690	BA 118	Retail Management
27315	BA 118	Retail Management
26679	BA 120	Management-Accounting and Internal Control
26722	BA 120	Management-Accounting and Internal Control
24205	BA 120	Management-Accounting and Internal Control
28093	BA 120	Management-Accounting and Internal Control
28578	BA 120	Management-Accounting and Internal Control
28579	BA 120	Management-Accounting and Internal Control
27734	BA 121	Sales
26828	BA 121	Sales
28580	BA 126	E-learning
22265	BA 132	Computer Applications for Managers
27012	BA 132	Computer Applications for Managers
29692	BA 132	Computer Applications for Managers
27007	BA 132	Computer Applications for Managers
25870	BA 132	Computer Applications for Managers
23024	BA 132	Computer Applications for Managers
28094	BA 132	Computer Applications for Managers
21525	BA 152	Fundamentals of Importing and Exporting
22006	BA 153	Small Business Management
28095	BA 153	Small Business Management
27320	BA 153	Small Business Management
23770	BA 155	Introduction to Global Logistics
23026	BA 156	Motivational Presentation Skills for Managers
25784	BA 156	Motivational Presentation Skills for Managers
22864	BA 156	Motivational Presentation Skills for Managers
27736	BA 156	Motivational Presentation Skills for Managers

DISTANCE EDUCATION COURSES (CONTINUED)

26728	BA 156	Motivational Presentation Skills for Managers
27737	BA 156	Motivational Presentation Skills for Managers
29693	BA 156	Motivational Presentation Skills for Managers
26730	BA 157	Principles of Public Relations
28096	BA 157	Principles of Public Relations
27322	BA 204	Project Management
23771	BA 205	Organizational Leadership
29162	BA 205	Organizational Leadership
25732	BA 208	Leadership for Women in Business
24206	BA 208	Leadership for Women in Business
29029	BA 208	Leadership for Women in Business

BUSINESS COMMUNICATIONS OFFICE TECHNOLOGY

28774	BCOT 46	Business Communications
21051	BCOT 62	Computer Keyboarding
21442	BCOT 62	Computer Keyboarding
21112	BCOT 63	Keyboarding Speed/Control Building
21462	BCOT 63	Keyboarding Speed/Control Building
29166	BCOT 96	Microsoft PowerPoint
29167	BCOT 96	Microsoft PowerPoint
21517	BCOT 97	Microsoft Outlook
21518	BCOT 97	Microsoft Outlook
21519	BCOT 112	Microsoft Word
21520	BCOT 112	Microsoft Word
21998	BCOT 113	Microsoft Excel
21999	BCOT 113	Microsoft Excel
21521	BCOT 114	Introduction to Microsoft Office
21522	BCOT 114	Introduction to Microsoft Office
22140	BCOT 118	Microsoft Access for Office Technology
22141	BCOT 118	Microsoft Access for Office Technology
30007	BCOT 148	Effective Business Presentations
26165	BCOT 155	Administrative Secretarial Procedures
26166	BCOT 155	Administrative Secretarial Procedures
25737	BCOT 161	Principles of Filing
25738	BCOT 161	Principles of Filing
27014	BCOT 247	Managerial Business Communications
29180	BCOT 247	Managerial Business Communications

CHILD DEVELOPMENT

21485	CD 110	Child Development
-------	--------	-------------------

CHILD DEVELOPMENT/EARLY CHILDHOOD

22503	CDEC 161	Health, Safety, and Nutrition
-------	----------	-------------------------------

CHINESE

27766	CHIN 260	Chinese Culture and Society
-------	----------	-----------------------------

COMMUNICATION STUDIES

29920	COMM 100	Introduction to Communications Studies
29922	COMM 100	Introduction to Communications Studies
29923	COMM 100	Introduction to Communications Studies
29926	COMM 100	Introduction to Communications Studies
29937	COMM 100	Introduction to Communications Studies
30082	COMM 100	Introduction to Communications Studies
29940	COMM 110	Intercultural Communication
29941	COMM 110	Intercultural Communication
29943	COMM 115	Gender, Communication, and the Digital Revolution
29944	COMM 115	Gender, Communication, and the Digital Revolution
29973	COMM 200	Contemporary Communication Topics

COMPUTER AND INFORMATION SCIENCES

25772	CIS 58A	PC Operating System A+ Certification
25773	CIS 58A	PC Operating System A+ Certification
26106	CIS 58B	PC Core Hardware A+ Certification
26107	CIS 58B	PC Core Hardware A+ Certification
20847	CIS 101	Introduction to Computer Information Systems
21369	CIS 101	Introduction to Computer Information Systems
20849	CIS 101	Introduction to Computer Information Systems
21371	CIS 101	Introduction to Computer Information Systems
28783	CIS 101	Introduction to Computer Information Systems
28784	CIS 101	Introduction to Computer Information Systems
21114	CIS 101	Introduction to Computer Information Systems
21463	CIS 101	Introduction to Computer Information Systems
28678	CIS 101	Introduction to Computer Information Systems
28679	CIS 101	Introduction to Computer Information Systems
27793	CIS 101	Introduction to Computer Information Systems
27794	CIS 101	Introduction to Computer Information Systems
21802	CIS 102	Introduction to Microcomputer Hardware and Applications Software
21803	CIS 102	Introduction to Microcomputer Hardware and Applications Software
20322	CIS 103	Computer Programming Logic
21225	CIS 103	Computer Programming Logic
23729	CIS 103	Computer Programming Logic
23730	CIS 103	Computer Programming Logic
26851	CIS 103	Computer Programming Logic
26852	CIS 103	Computer Programming Logic
20852	CIS 155	Microsoft Access
21373	CIS 155	Microsoft Access
27305	CIS 160	Web Page Development
27306	CIS 160	Web Page Development
23638	CIS 162	HTML and CSS
23639	CIS 162	HTML and CSS
24147	CIS 170A	Networking Fundamentals
24148	CIS 170A	Networking Fundamentals
24149	CIS 170B	Network + Certification
24150	CIS 170B	Network + Certification
24139	CIS 170F	Advanced Switching and Routing
24140	CIS 170F	Advanced Switching and Routing
24141	CIS 170G	Wide Area Networks
24142	CIS 170G	Wide Area Networks
26866	CIS 170H	TCP/IP Fundamentals
30133	CIS 170K	Introduction to Wireless Networking
26110	CIS 170P	Introduction to Ethical Hacking
26111	CIS 170P	Introduction to Ethical Hacking
27795	CIS 170R	Computer and Digital Forensics
27796	CIS 170R	Computer and Digital Forensics
30134	CIS 180	Programming in C/C++
30135	CIS 180	Programming in C/C++
26098	CIS 183	Java Programming
26099	CIS 183	Java Programming
28781	CIS 183	Java Programming
28782	CIS 183	Java Programming
29049	CIS 189C	Special Topics in Software Development
21919	CIS 202A	Project Management for Information Technology
21920	CIS 202A	Project Management for Information Technology
30136	CIS 202B	Microsoft Project
30137	CIS 202B	Microsoft Project
26102	CIS 207	Database Design and SQL
26103	CIS 207	Database Design and SQL
26684	CIS 208A	Oracle SQL and PL/SQL
26685	CIS 208A	Oracle SQL and PL/SQL
23646	CIS 212	Introduction to Microsoft Windows Administration
23647	CIS 212	Introduction to Microsoft Windows Administration
21921	CIS 213F	Microsoft Windows Server Administration
21922	CIS 213F	Microsoft Windows Server Administration
29667	CIS 285A	ASP.Net Programming
29668	CIS 285A	ASP.Net Programming
29991	CIS 286	Software Development with C#
29992	CIS 286	Software Development with C#

DISTANCE EDUCATION COURSES (CONTINUED)

COUNSELING

30119	COUN 200	Success in College and Career
23156	COUN 200	Success in College and Career
29568	COUN 200	Success in College and Career
29997	COUN 200	Success in College and Career

DANCE

27221	DANC 100	Dance Appreciation
22148	DANC 100	Dance Appreciation
22147	DANC 100	Dance Appreciation
28111	DANC 100	Dance Appreciation
28112	DANC 100	Dance Appreciation
22831	DANC 100	Dance Appreciation
28259	DANC 100	Dance Appreciation
28295	DANC 100	Dance Appreciation
29216	DANC 100	Dance Appreciation
28150	DANC 101	History of Dance

EARTH SCIENCE

20875	ESCI 104	Oceanography
28253	ESCI 104	Oceanography
29669	ESCI 106	Weather and Climate

ECONOMICS

25685	ECON 101	Economic Issues and Policy
28039	ECON 201	Principles of Macroeconomics
28040	ECON 201	Principles of Macroeconomics
23565	ECON 201	Principles of Macroeconomics
23566	ECON 201	Principles of Macroeconomics
27299	ECON 201	Principles of Macroeconomics
27300	ECON 201	Principles of Macroeconomics
23567	ECON 201M	Principles of Macroeconomics
23568	ECON 201M	Principles of Macroeconomics
28041	ECON 201M	Principles of Macroeconomics
28042	ECON 201M	Principles of Macroeconomics
27301	ECON 201M	Principles of Macroeconomics
27302	ECON 201M	Principles of Macroeconomics
22590	ECON 202	Principles of Microeconomics
22591	ECON 202	Principles of Microeconomics
28589	ECON 202	Principles of Microeconomics
28590	ECON 202	Principles of Microeconomics
22447	ECON 202M	Principles of Microeconomics
22554	ECON 202M	Principles of Microeconomics
28591	ECON 202M	Principles of Microeconomics
28592	ECON 202M	Principles of Microeconomics

EDUCATION

22359	EDEL 100	Introduction to Teaching and Learning in Diverse Contemporary Classrooms
-------	----------	--

EDUCATIONAL TECHNOLOGY (EDTCH)

29695	EDT 116	Information Literacy for Educators
29696	EDT 123	Internet Tools for Educators
27748	EDT 170	Using a CMS/LMS for Education

ENGINEERING DESIGN TECHNOLOGY

28963	ENGT 116	Blueprint Reading
28964	ENGT 116	Blueprint Reading
27926	ENGT 117	Geometrical Dimensioning and Tolerancing
28756	ENGT 237	Statics and Strength of Materials Using Simulation
28757	ENGT 237	Statics and Strength of Materials Using Simulation
26955	ENGT 259	Solidworks Introduction
26956	ENGT 259	Solidworks Introduction

ENGLISH

20375	ENGL 100	Freshman Composition
20378	ENGL 100	Freshman Composition
25813	ENGL 100	Freshman Composition
20380	ENGL 100	Freshman Composition
20386	ENGL 100	Freshman Composition
23798	ENGL 100	Freshman Composition
20387	ENGL 100	Freshman Composition
20388	ENGL 100	Freshman Composition
23740	ENGL 100	Freshman Composition
23741	ENGL 100	Freshman Composition
22454	ENGL 100	Freshman Composition
21910	ENGL 100	Freshman Composition
22231	ENGL 100	Freshman Composition
22810	ENGL 100	Freshman Composition
28887	ENGL 100	Freshman Composition
20390	ENGL 100	Freshman Composition
23746	ENGL 100	Freshman Composition
29208	ENGL 100	Freshman Composition
29209	ENGL 100	Freshman Composition
20369	ENGL 100	Freshman Composition
29119	ENGL 100	Freshman Composition
28280	ENGL 100	Freshman Composition
21530	ENGL 103	Critical and Argumentative Writing
26773	ENGL 103	Critical and Argumentative Writing
23804	ENGL 103	Critical and Argumentative Writing
27346	ENGL 103	Critical and Argumentative Writing
26775	ENGL 103	Critical and Argumentative Writing
28173	ENGL 103	Critical and Argumentative Writing
28555	ENGL 103	Critical and Argumentative Writing
28556	ENGL 103	Critical and Argumentative Writing
25308	ENGL 103	Critical and Argumentative Writing
28260	ENGL 103	Critical and Argumentative Writing
28261	ENGL 103	Critical and Argumentative Writing
28890	ENGL 103	Critical and Argumentative Writing
29869	ENGL 110	Critical Thinking through Literature
28560	ENGL 227	Modern and Contemporary Literature
29870	ENGL 239	Literature of India

ENGLISH AS A SECOND LANGUAGE

26891	ESL 11	ESL Reading 1
30074	ESL 21A	ESL Intermediate Vocabulary
26757	ESL 31	ESL Reading 2
25844	ESL 57	TOEFL Preparation Course

FINANCE

22059	FIN 125	Personal Finance
23470	FIN 125	Personal Finance
22060	FIN 125	Personal Finance
28084	FIN 125	Personal Finance
23471	FIN 125	Personal Finance

GEOGRAPHY

28712	GEOG 102	Cultural Geography
28226	GEOG 105	World Regional Geography

DISTANCE EDUCATION COURSES (CONTINUED)

HEALTH EDUCATION

26445	HED 100	Contemporary Health Problems
20890	HED 100	Contemporary Health Problems
21567	HED 100	Contemporary Health Problems
21573	HED 100	Contemporary Health Problems
21656	HED 100	Contemporary Health Problems
21117	HED 100	Contemporary Health Problems
21572	HED 100	Contemporary Health Problems
22604	HED 100	Contemporary Health Problems
26835	HED 100	Contemporary Health Problems
29222	HED 100	Contemporary Health Problems
30088	HED 101	Stress Management
30089	HED 101	Stress Management
30090	HED 101	Stress Management
30091	HED 101	Stress Management
29733	HED 104	Introduction to Health and Society
28972	HED 105	Mind, Body, and Health
28973	HED 202	Health Systems and Perspectives

HISTORY

27276	HIST 102	Political and Social History of the United States: 1500s to 1876
28050	HIST 102	Political and Social History of the United States: 1500s to 1876
28051	HIST 102	Political and Social History of the United States: 1500s to 1876
27278	HIST 103	Political and Social History of the United States: 1877 to Present
28052	HIST 103	Political and Social History of the United States: 1877 to Present

HUMANITIES

20449	HUM 100	The Art of Being Human
-------	---------	------------------------

JOURNALISM

28134	JOUR 100	Mass Communications and Society
-------	----------	---------------------------------

KINESIOLOGY

27860	KIN 100	Introduction to Kinesiology
28140	KIN 100	Introduction to Kinesiology
28141	KIN 100	Introduction to Kinesiology
28843	KIN 100	Introduction to Kinesiology
29193	KIN 100	Introduction to Kinesiology
29221	KIN 100	Introduction to Kinesiology
25326	KIN 104	Fitness and Wellness
25335	KIN 108	Women in Sports
27222	KIN 108	Women in Sports
29740	KIN 200	Sports Psychology

LAW

26168	LAW 110	Business Law
27260	LAW 111	Business Law

MACHINE TOOL TECHNOLOGY

26961	MTT 62	Fixture Tooling
-------	--------	-----------------

MATHEMATICS

28079	MATH 112	Elementary Statistics
29025	MATH 112	Elementary Statistics
29045	MATH 112	Elementary Statistics
29050	MATH 114	College Algebra
27084	MATH 114	College Algebra
29024	MATH 114	College Algebra

MEDICAL ASSISTANT

23290	MA 161	Medical Terminology
21055	MA 161	Medical Terminology

MUSIC

27851	MUS 100	Music Appreciation
20544	MUS 101	Introduction to World Music
21593	MUS 104B	History of Rock Music
22880	MUS 104B	History of Rock Music
29225	MUS 105	Music Fundamentals

PHILOSOPHY

28955	PHIL 102	Introduction to Ethics
28956	PHIL 102	Introduction to Ethics
26353	PHIL 104	Philosophy of Cultural Diversity: Challenge and Change

POLITICAL SCIENCE

23348	POL 101	American Political Institutions
20662	POL 101	American Political Institutions
23349	POL 101	American Political Institutions
20991	POL 101	American Political Institutions
21651	POL 101	American Political Institutions
22624	POL 101	American Political Institutions
27280	POL 101	American Political Institutions
21550	POL 101	American Political Institutions
21551	POL 101	American Political Institutions
21553	POL 101	American Political Institutions
24186	POL 101	American Political Institutions
27323	POL 101	American Political Institutions
27281	POL 101	American Political Institutions

PSYCHOLOGY

20680	PSYC 101	General Introductory Psychology
20681	PSYC 101	General Introductory Psychology
28581	PSYC 101	General Introductory Psychology
21554	PSYC 101	General Introductory Psychology
20684	PSYC 101	General Introductory Psychology
20995	PSYC 101	General Introductory Psychology
22634	PSYC 241	Introduction to Psychobiology
29703	PSYC 261	Social Psychology

READING

28219	READ 49	Introduction to College Reading
30078	READ 54	Advanced College Reading
29895	READ 102	Academic Reading in the Content Areas
23754	READ 200	Analysis and Critical Reading
28222	READ 200	Analysis and Critical Reading

DISTANCE EDUCATION COURSES (CONTINUED)

REAL ESTATE

22066	RE 101	Real Estate Principles
22076	RE 101	Real Estate Principles
23507	RE 130	Real Estate Practice
23506	RE 130	Real Estate Practice

SOCIOLOGY

29187	SOC 101	Introductory Sociology Principles
-------	---------	-----------------------------------

SPANISH

21029	SPAN 245	Introduction to Chicano/Mexican American Culture
-------	----------	--

SPEECH

29559	SLP 105	Speech and Language Development in
-------	---------	------------------------------------

THEATRE ARTS

20756	TH 101	Introduction to the Theatre
28214	TH 101	Introduction to the Theatre
28736	TH 101	Introduction to the Theatre
28215	TH 101	Introduction to the Theatre
28740	TH 101	Introduction to the Theatre
20763	TH 150	Appreciation and History of the Motion Picture
21627	TH 150	Appreciation and History of the Motion Picture

WOMEN'S AND GENDER STUDIES

25696	WGS 108	Women in Sports
28137	WGS 108	Women in Sports
29712	WGS 115	Gender, Communication, and the Digital Revolution
28777	WGS 115	Gender, Communication, and the Digital Revolution
24196	WGS 208	Leadership for Women in Business
27063	WGS 208	Leadership for Women in Business
29030	WGS 208	Leadership for Women in Business



SEXUAL AND GENDER-BASED MISCONDUCT

POLICY ON AFFIRMATIVE CONSENT, SEXUAL ASSAULT, AND TITLE IX

Cerritos College is committed to providing a safe and secure environment for all members of the campus community. Board Policy and Administrative Procedure 3540: Sexual and Other Assaults on Campus, operationalize relevant State and Federal Laws. These cover sexual assaults including rape, sexual battery, and threat of sexual assault; dating violence; domestic violence; stalking; and failure to have affirmative consent. District response including claimant options, victim resources, case investigation, and administrative and law enforcement response are provided in Administrative Procedure 3540. Any student or employee who becomes a victim of sexual violence, dating violence, domestic violence, or stalking is encouraged to report the matter immediately to Dr. Valyncia C. Raphael, District Title IX Coordinator in the Office of Human Resource Services. The phone number for the Title IX Coordinator is (562) 860-2451, ext. 2276, and the email address is TitleIXcoordinator@cerritos.edu. Additional information is available at <https://www.cerritos.edu/title-ix>.

The District is dedicated to providing prompt and compassionate services. In the event of an incident, Student Health Services will provide confidential support services and direction. The phone number for Student Health Services is (562) 860-2451, ext. 2321.

For more information, please see Board Policy 3540 and Administrative Procedure 3540: Sexual and Other Assaults on Campus. This Policy and Procedure are on the Board Policy web page at: <https://www.cerritos.edu/board/policies>.

AFFIRMATIVE CONSENT POLICY

Board Policy 3540 and 5500 define “affirmative consent” as affirmative, conscious, and voluntary agreement to engage in sexual activity. Lack of protest or resistance does not mean consent, nor does silence mean consent. Affirmative consent must be ongoing throughout a sexual activity and can be revoked at any time. The existence of a dating relationship between the persons involved, or the fact of past sexual relations between them, should never by itself be assumed to be an indicator of consent. People under 18 years old; incapacitated by drugs, alcohol, or medication; asleep, unconscious or otherwise unable to understand the fact, nature, or extent of the sexual activity cannot give consent. Failure, as a person involved in sexual activity, to ensure mutual, affirmative consent throughout sexual activity constitutes good cause for discipline, including but not limited to the removal, suspension, or expulsion of a student.

Information about violators of this policy are encouraged to report this matter immediately to the Director of Diversity, Compliance, and Title IX Coordinator in the Office of Human Resources or the Campus Police. The number for the Campus Police is (562) 860-2451, ext. 2325.

SEXUAL HARASSMENT

It is the policy of the Cerritos Community College District to provide an educational, employment, and business environment free of unwelcome sexual advances, requests or offers for sexual favors, and other verbal or physical conduct or communications constituting sexual harassment, as defined and otherwise prohibited by federal and state statutes and Board Policy.

The Board of Trustees and the President-Superintendent have provided regulations and procedures to implement this policy and the regulations and procedures are included as a part of the District's Equal Employment Opportunity Plan and Board Policy.

It is a violation of Board Policy for anyone who is authorized to recommend or take personnel or academic actions affecting an employee or student, or who is otherwise authorized to transact business or perform other acts or services on behalf of the Cerritos Community College District, to engage in sexual harassment as defined in Board Policy or as described below.

Sexual harassment occurs when unwelcome sexual advances, requests for sexual favors and other verbal or physical conduct of a sexual nature takes place and:

1. Is made explicitly or implicitly a term or condition of an individual's educational status or employment; or
2. Is used as a basis for educational or employment decisions affecting such individual; or
3. Has the purpose or effect of unreasonably interfering with an individual's work performance or creating an intimidating, hostile or offensive educational or working environment; or
4. Is used as the basis for any decision affecting the individual regarding benefits, services, honors, programs, or activities available at or through the District. Informal and formal complaints under this policy shall be processed through the District's Administrative Procedure 3435: Discrimination and Harassment Investigations, through the Director of Diversity, Compliance, and Title IX Coordinator. The District's Policies and Procedures are available on the website at <https://www.cerritos.edu/board/policies>.

// Stay Falcon Safe! //

We are Falcons! We always keep our nest safe and look out for each other.

<p>IF YOU ARE EXPERIENCING</p> <ul style="list-style-type: none">• Stalking• Bullying, verbal or written threats• Cyberbullying• Dating or domestic violence• Sexual or physical assault	<p>HELP IS AVAILABLE</p> <p>Dial 562-860-2451 plus the extension below:</p> <p>On-Campus Resources</p> <ul style="list-style-type: none">• Student Health Services: Ext. 2321• Campus Police: 911 or Ext. 3076• Student Conduct and Grievances: Ext. 2473• Title IX, including Sexual Harassment: Ext. 2276• Bicycle Safety and Theft Prevention: Ext. 3076
---	--

NOTIFICATION OF RIGHTS UNDER FERPA

The Family Educational Rights and Privacy Act (FERPA) affords students certain rights with respect to their education records. These rights include:

- 1) The right to inspect and review the student's education records within 45 days of the day the College receives a request for access.

A student should submit to the registrar or designee a written request that identifies the record(s) the student wishes to inspect. The registrar will make arrangements for access and notify the student of the time and place where the records may be inspected. If the records are not maintained by the registrar, the registrar shall advise the student of the correct official to whom the request should be addressed.

- 2) The right to request the amendment of the student's education records that the student believes are inaccurate, misleading, or otherwise in violation of the student's privacy rights under FERPA.

A student who wishes to ask the College to amend a record should write the registrar, clearly identify the part of the record the student wants changed, and specify why it should be changed.

If the College decides not to amend the record as requested, the College will notify the student in writing of the decision and the student's right to a hearing regarding the request for amendment. Additional information regarding the hearing procedures will be provided to the student when notified of the right to a hearing.

- 3) The right to provide written consent before the College discloses personally identifiable information from the student's education records, except to the extent that FERPA authorizes disclosure without consent.

The College discloses education records without a student's prior written consent under the FERPA exception for disclosure to school officials with legitimate educational interests. A school official is a person employed by the College in an administrative, supervisory, academic or research, or support staff position (including law enforcement unit personnel and health staff); a person or company with whom the College has contracted as its agent to provide a service instead of using College employees or officials (such as an attorney, auditor, or collection agent); or a student serving on an official committee, such as a disciplinary or grievance committee, or assisting another school official in performing his or her tasks.

A school official has a legitimate educational interest if the official needs to review an education record in order to fulfill his or her professional responsibilities for the College. The College may also disclose education records without consent to officials of another school in which a student seeks or intends to enroll.

- 4) The right to file a complaint with the U.S. Department of Education concerning alleged failures by the College to comply with the requirements of FERPA. The name and address of the office that administers FERPA is:

Family Policy Compliance Office
U.S. Department of Education
400 Maryland Avenue, SW
Washington, DC 20202-5901

DIRECTORY INFORMATION

Cerritos College will not release personal data about students without their prior written consent except to persons and agencies authorized by law. The college may make an exception to legitimate inquiries, by providing general directory information to include: name • major field of study • class level • dates of attendance • degrees and awards received • participation in officially recognized activities and sports • weight and height of members of athletic teams, and • previous educational institutions attended.

STUDENT RECORDS CONSENT

Cerritos College may permit access to student records to any person for whom the student has executed written consent specifying the records to be released and identifying the party or parties to whom the records may be released. Such consent must be signed and dated by the student. The recipient must be notified that the transmission of the information to others is prohibited (California Administrative Regulations, Title 5, Section 54616).

WITHHOLDING OF STUDENT RECORDS

Student records may be withheld pending satisfaction of certain requirements, per Board Policy and Administrative Procedure 5035.

Reference: Board Policy and Administrative Procedure 5040



GENERAL EDUCATION REQUIREMENTS FOR THE ASSOCIATE DEGREE AND FOR TRANSFER TO THE CALIFORNIA STATE UNIVERSITY AND UNIVERSITY OF CALIFORNIA

Requirements for the Associate in Arts (A.A.) Degree at Cerritos College can be met in one of three different ways: Plan A, B, or C.

PLAN A is designed primarily for those students interested in preparing for a vocational career upon graduation. Plan A may also be used by university transfer students and for students in vocational majors who may possibly wish to transfer in the future; however, there are courses listed under Plan A that are not transferable for general education credit to the four-year universities. Therefore, students wishing to use this option should see a Cerritos College counselor for advice in selecting the A.A. General Education plan that, in combination with a major, will best match their educational and career goals. Please see the Plan A degree description page for further details.

PLAN B is designed primarily for students who will transfer to a California State University (CSU) campus and are not interested in attending a University of California campus. Students may use this plan to combine completion of both the Associate in Arts general education requirements, and the California State University (CSU) General Education Certification pattern. Students should see a counselor for advice on selecting the A.A. General Education plan that, in combination with a major, will best match their educational and career goals. Please see the Plan B degree description page for further details.

PLAN C is designed primarily for students who intend to transfer to the University of California (UC), or who are undecided between transferring to the University of California or the California State University. Students may use this plan to combine completion of both the A.A. degree general education requirements and the Intersegmental General Education Transfer Curriculum (IGETC) requirements. Plan C may not be recommended for some majors at certain CSU or UC campuses. Please see the Plan C description page for further details.

The significant differences between Plan A, Plan B, and Plan C are:

Plan A requires the completion of a minimum of 18 units of identified general education courses and requirements and a minimum of 18 units of specified “major” courses, as well as proficiency requirements and electives if necessary, to total a minimum of 60 degree applicable units.

Plan B requires a minimum of 39 units of identified CSU general education courses and requirements plus specified major courses, the health and wellness proficiency requirement, and elective courses if necessary, for a minimum of 60 degree applicable units.

If a student only wishes to transfer at an upper division level and is not seeking an A.A. degree, a minimum of 60 CSU transferable units is required (see transfer requirements for CSU and your counselor).

Plan C requires a minimum of 34 (UC) or 37 (CSU) units of identified general education courses and requirements plus specified major courses, the health and wellness proficiency requirement, and electives if necessary, to total a minimum of 60 degree applicable units.

If a student only wishes to transfer at an upper division level and is not seeking an A.A. degree, a minimum of 60 UC transferable units is required (see IGETC, UC transfer requirements, and your counselor).

There are important differences among the three plans. In order to select the plan that best meets each individual’s A.A. and transfer goals, students should see a Cerritos College counselor.



GENERAL EDUCATION REQUIREMENTS FOR THE ASSOCIATE DEGREE

Associate in Arts Degree General Education 2019-20 Plan A Degree and/or Career Option

A total of 60 degree applicable units, including the following requirements, must be completed to qualify for the A.A. degree:

1. MAJOR PROGRAM REQUIREMENTS:
Complete all requirements for the chosen major program under "Major Requirements" in the Cerritos College Catalog.
 2. MATHEMATICS PROFICIENCY REQUIREMENT:
This requirement can be met by one of the following options:
 - a. Completion of MATH 80 or MATH 80B or MATH 75 or equivalent with a grade of "C" or higher or "Pass".
 - b. Completion of high school Algebra 2 or Integrated Math 3 with a grade of "C" or higher. Documentation is required.
 - c. For other options, see your counselor.
 3. READING PROFICIENCY REQUIREMENT:
This requirement can be met by one of the following options:
 - a. Completion of READ 54 or READ 97 or READ 102 or equivalent with a grade of "C" or higher or "Pass".
 - b. For other options, see your counselor.
 4. WRITING PROFICIENCY REQUIREMENT:
Completion of ENGL 100 or ENGL 100S or equivalent with a grade of "C" or higher or "Pass".
 5. HEALTH AND WELLNESS PROFICIENCY REQUIREMENT:
This requirement can be met by one of the of the following options:
 - a. Completion with a grade of Pass, or "C", or higher of at least one unit of a course from the approved department list below:
Athletics 200L, 201LA, 201LB, 201LC, 202L, 203LA, 203LB, 203LC, 204L, 205LA, 205LB, 205LC, 205LD, 205LE, 206L, 207LA, 207LB, 207LC, 208L, 209LA, 209LB, 209LC, 210L, 211LA, 211LB, 211LC, 212L, 213LA, 213LB, 213LC, 214L, 215LA, 215LB, 215LC, 216L, 217LA, 217LB, 217LC, 218L, 219LA, 219LB, 219LC, 220L, 221LA, 221LB, 221LC, 221LD, 222L, 223LA, 223LB, 223LC, 223LD, 224L, 225LA, 225LB, 225LC, 225LD, 226L, 227LA, 227LB, 227LC, 228L, 229LA, 229LB, 229LC, 230L, 231LA, 231LB, 231LC, 232L, 233LA, 233LB, 233LC, 234L, 235LA, 235LB, 235LC, 235LD, 236L, 237LA, 237LB, 237LC, 240, 241, 242
Kinesiology 100, 102, 104, 106, 120, 121, 122, 123, 130, 131, 132, 133, 134, 200, 202, 203, 206, 207, 210
Physical Education Exercise 100, 100A, 101, 102, 103, 103A, 104, 105, 106, 106A, 107, 107A, 108, 109, 110, 111, 112, 113, 116, 117, 118, 119, 120, 121, 122, 124, 126, 130, 132, 134, 135, 136, 138, 139, 140, 141, 142, 145, 147, 148, 149, 150, 151, 152, 153, 155, 156, 157, 161, 162, 163, 165, 166, 167, 169, 170, 171, 172, 176, 177, 178, 179, 181, 184, 185, 186, 188, 189, 191, 192, 194, 240, 245, 246, 249, 261, 263, 265, 266, 267, 271, 272, 274, 276, 278, 281, 282, 284, 285, 288, 289, 291, 292
Other courses that will meet the requirement include Dance 102, 105, 106A, 106B, 107, 108A, 108B, 108C, 109, 110, 112, 120, 121, 122, 123, 124, 125, 126, 130A, 130B, 133, 134, 135, 136, 140, 141, 142, 143, 144, 150, 151
 - b. Completion of HED 100, 101, 103, 105 or 200; HO 100 or 152; CDEC 161; or WGS 103.
 - c. Enrollment and completion of Allied Health program (DA, DH, RN, PTA, Pharm Tech, MA).
 - d. For other options, see your counselor.
6. GENERAL EDUCATION REQUIREMENTS: PLAN A 18 UNITS
 - a. NATURAL SCIENCES: 3 UNITS MINIMUM FROM EITHER PHYSICAL SCIENCES OR BIOLOGICAL SCIENCES
 - (1) Physical Sciences
Astronomy 102, 103, 104, 105L (lab), 106
Chemistry 100 (lab), 110 (lab), 111 (lab), 112 (lab)
Earth Science 101, 102 (lab), 104, 104L (lab), 106, 110 (lab)
Energy 100
Geography 101, 101L (lab), 103
Geology 101 (lab), 102, 102L (lab), 103, 103L (lab), **105L (lab), 201 (lab), 204, 207 (lab), 208, 209
Physical Science 100, 112 (lab)
Physics 100 (lab), 101 (lab), 102 (lab), 201 (lab), 202 (lab), 203 (lab)
 - (2) Biological Sciences
Anatomy and Physiology 120 (lab), 150 (lab), 151 (lab), 200 (lab), 201 (lab)
Anthropology **110, 115, 115L (lab)
Biology 105, 110 (lab), 115 (lab), 120 (lab), 200 (lab), 201 (lab)
Botany 120 (lab)
Microbiology 200 (lab)
Psychology 241
Zoology 120 (lab)
 - b. SOCIAL AND BEHAVIORAL SCIENCES: 3 UNITS MINIMUM
NOTE: Completion of a U.S. history or government course which fulfills the California State University requirement taken at any accredited institution may be used in lieu of the course requirement.
One course from Section B1 or B2 is required.
 - (1) History 101, 102, 103
(This requirement can be met by successfully passing the College Board's Advanced Placement Exam, U.S. History. Unit credit is awarded for passing the AP exam option with a score of 3 or higher.)
 - (2) Political Science 101 or 201
(This requirement can be met by successfully passing the College Board's Advanced Placement exam, U.S. Government and Politics. Unit credit is awarded for passing the Advanced Placement exam option with a score of 3 or higher.)
 - (3) Social and Behavioral Sciences
Administration of Justice 101
American Sign Language 220
Anthropology 100, 120, 170, 200, 201, 202, 203, 205, 206
Business Administration **208
Child Development 110
Child Development/Early Childhood **113
Communication Studies 110, 115
Counseling **150, 200

GENERAL EDUCATION REQUIREMENTS FOR THE ASSOCIATE DEGREE

- Economics 101, 102, 201, 201M, 202, 202M, 204
 Environmental Policy 200
 Finance **125
 Geography 102, 105, 140
 Health Education ***103
 History 110, 120, 204, 210, ***220, ***221, 230, 235, 241, 242, 245, 246, 250, 255, 260, 265, **270, 275
 Humanities 107
 Journalism 100
 Kinesiology 108, ***211
 Political Science 110, 210, 220, 230, 240, ***250, 260
 Psychology 101, 150, 251, 261, 271
 Reading 101
 Sociology 101, 110, 120, 201, 202, 205, 210, 215, **225, 230, 250
 Speech Language Pathology **105
 Women's and Gender Studies 101, ***103, 105, 107, 108, 115, **140, 202, 204, 205, 206, **208, 209, 250,
- c. FINE ARTS AND HUMANITIES: 3 UNITS MINIMUM FROM EITHER FINE ARTS OR HUMANITIES

(1) FINE ARTS

- Architecture **110, 112
 Art 100, 101, 102, 103, 104, 105A, 105B, 106, 107, *108, *109, 110, 113, 116, 118, **119A, 120, 130A, 150, **186, **192, 193, **200
 Communication Studies **148
 Dance 100, 101
 Film 159
 Humanities *108, *109, **200
 Music 100, 101, 102, 103, 104, 104B, 105, 180
 Photography 100, 160
 Theatre 101, 102, 103, 104, **110, 150, RTV/TH 151, RTV 152
 Women's and Gender Studies 118

(2) HUMANITIES

- American Sign Language 110, 111, ***210, ***211
 Art *108, *109, 124, 125, 207
 Chinese 101, 102, 201, 202, 260
 Communication Studies 140, **145
 English 102, 106, 221A, 221B, 222, 223, 224, 225, 226, 227, 228, 230A, 230B, ***231, 232, 233, 234, 235, 236, 237, 238, 239, **242, **243, **244, 245, 246A, 246B, **247, ***248A, 248B, ***249
 French 101, 102, 201, 202, 203, 281, 282, 283, 285
 German 101, 102, 201, 202
 Humanities 100, *108, *109, 125
 Japanese 101, 102, 201, 202
 Philosophy 100, 102, 104, 105, 107, 108, 109, 130, 140, 200, 201, 203, 204, 205, 206
 Photography 150
 Spanish 101, 102, 111, 112, 201, 202, 206, 210, 245, 260, 285
 Women's and Gender Studies 102, 109, 207

- d. LANGUAGE AND RATIONALITY: 6 UNITS MINIMUM
 Select at least three units from Section D1 and three units from Section D2:

(1) ENGLISH COMPOSITION

English 100, 100S

(2) COMMUNICATION AND ANALYTICAL THINKING

- Business Communication **148
 Communication Studies **60, 100, 103, 120, 125, 130, 132
 Computer and Information Sciences **101, **102, **103
 Engineering Design Technology **131
 English 103, 110
 Mathematics **80, **80B, ***110A, ***110B, 112, 114, 115, 116, ***140, 155, 160, 170, 190, 225, 250
 Philosophy 103, 106, **160
 Psychology 103, 210
 Reading 200

- e. Select an additional general education course from those listed above or a course from Plan B or Plan C so that the earned general education units total at least 18.

* These courses appear in more than one category, but may only be counted once.

** These courses do not meet the General Education Requirements for CSU or IGETC.

*** These courses do not meet the General Education Requirements for IGETC.

NOTE: *The preceding graduation requirements apply to students who were in attendance during the 2019-20 school year and thereafter. Students who enrolled prior to Fall 2019 and who have maintained continuous attendance at Cerritos College have the option of meeting the current requirements or those in effect at the time continuous attendance began.*



GENERAL EDUCATION REQUIREMENTS FOR THE ASSOCIATE DEGREE AND FOR TRANSFER TO THE CALIFORNIA STATE UNIVERSITY

Associate in Arts Degree General Education 2019-20 Plan B and/or The General Education Certification Requirements For The Bachelor's Degree At The California State University

Plan B is designed primarily for students who will transfer to a California State University (CSU) campus and are not interested in attending a University of California campus. Students may use this plan to combine completion of both the Associate in Arts general education requirements and the CSU General Education Certification pattern. Students should see a counselor for advice on selecting the A.A. General Education plan that, in combination with a major, will best match their educational and career goals.

To earn an Associate in Arts Degree using Plan B, students must complete a minimum of 60 degree applicable units with an overall grade point average of "C" (2.0) or higher, which must include the specified general education requirements and designated courses for a major. The Health and Wellness Proficiency requirement must be completed (see description in Plan A).

If a student wishes only to transfer and is not seeking an A.A. degree, they can follow the requirements below; however, there are no proficiencies required for CSUGE certification.

It should be noted that completion of the CSU General Education Certification is not required for admission to the CSU, nor is it the only way to fulfill the lower division general education requirements. Depending upon the student's major, it may be advantageous to complete the requirements of the specific campus the student plans to attend.

CALIFORNIA STATE UNIVERSITY GENERAL EDUCATION CERTIFICATION REQUIREMENTS

A maximum of 39 units is required to fulfill the CSU lower division general education requirements, with the units to be distributed as follows: Nine (9) units in Area A; nine (9) units in Areas B, C and D, with no more than 30 units total in areas B through D combined; and three (3) units in Area E.

A letter grade of "C" or higher is required in Oral Communication, Written Communication, Critical Thinking, and Mathematical Concepts.

Note: Courses appearing in more than one category may be used to satisfy only one category. Such courses are marked with an *.

- A) Communications: 9 units minimum.
Must take one course from category 1, 2, and 3
 - 1. Oral Communication
Communication Studies 100, 120, 125, 130, 132
 - 2. Written Communication
English 100, 100S
 - 3. Critical Thinking
Communication Studies 103
English 103, 110
Philosophy 103, 106
Psychology 103
Reading 200

- B) Natural Science and Mathematics: 9 units minimum.
Take a course from category 1, 2 and 3. AT LEAST ONE LABORATORY (LAB) MUST BE INCLUDED IN CATEGORY 1 or CATEGORY 2.
 - 1. Physical Sciences
Astronomy 102, 103, 104, 105L (lab), 106
Chemistry 100 (lab), 110 (lab), 111 (lab), 112 (lab)
Earth Science 101, 102 (lab), 104, 104L (lab), 106, 110 (lab)
Energy 100
Geography 101, 101L (lab), 103
Geology 101 (lab), 102, 102L (lab), 103, 103L (lab), 201 (lab), 204, 207 (lab), 208, 209
Physical Science 100, 112 (not considered a LAB science for CSU GE)
Physics 100 (lab), 101 (lab), 102 (lab), 201 (lab), 202 (lab), 203 (lab)
 - 2. Biological Sciences
Anatomy and Physiology 120 (lab), 150 (lab), 151 (lab), 200 (lab), 201 (lab)
Anthropology 115, 115L (lab)
Biology 105, 110 (lab), 115 (lab), 120 (lab), 200 (lab), 201 (lab), 202
Botany 120 (lab)
Microbiology 200 (lab)
Psychology 241
Zoology 120 (lab)
 - 3. Mathematical Concepts
+Finance 125M (see important footnote on page 125)
Mathematics 110A, 110B, 112, 114, 115, 116, 140, 155, 160, 170, 190, 225, 250
Psychology 210

- C) Fine Arts and Humanities: 9 units minimum.
Take one course in category 1 and 2. The third course may be taken in either category
 - 1. Fine Arts
Architecture 112
Art 100, 101, 102, 103, 104, 105A, 105B, 106, 107, *108, *109, 110, 113, 116, 118, 120, 130A, 150, 193
Dance 100, 101
Film 159
Humanities *108, *109
Music 100, 101, 102, 103, 104, 104B, 105, 180
Photography 100, 160

GENERAL EDUCATION REQUIREMENTS FOR THE ASSOCIATE DEGREE AND FOR TRANSFER TO THE CALIFORNIA STATE UNIVERSITY

Theatre 101, 102, 103, 104, 150, RTV/TH 151, RTV 152
Women's and Gender Studies 118

2. Humanities

American Sign Language 110, 111, 210, 211, *220
Art *108, *109, 124, 125, 207
Chinese 101, 102, 201, 202, 260
Communication Studies 140
English 102, 106, 221A, 221B, 222, 223, 224, 225, 226, 227, 228, 230A, 230B, 231, 232, 233, 234, 235, 236, 237, 238, 239, 245, 246A, 246B, 248A, 248B, 249
French 101, 102, 201, 202, 203, 281, 282, 283, 285
German 101, 102, 201, 202
History *101, *102, *103, *110, *120, *210, *220, *221, *230, *235, *241, *242, *245, *246, *250, *255, *260, *265, *275
Humanities 100, *108, *109, 125
Japanese 101, 102, 201, 202
Philosophy 100, 102, 104, 105, 107, 108, 109, 130, 140, 200, 201, 203, 204, 205, 206
Photography 150
Political Science *240
Spanish 101, 102, 111, 112, 201, 202, 205, 206, 210, 245, 260, 285
Women's and Gender Studies 102, 109, 207

D) Social Sciences: 9 units minimum.

Take one course in category 1, 2 and 3.

1. American History

History *101, *102, *103
(Any one of these courses meet the requirement in U.S. History)

2. American Government

Political Science 101, 201
(Either of these courses meet the requirement for Constitution and American Ideals)

3. Social, Political, Historical and Economic Institutions

Administration of Justice 101
American Sign Language *220
Anthropology 100, 120, 170, 200, 201, 202, 203, *205, 206
Child Development *110
Communication Studies 110, 115
Economics 101, 102, 201, 201M, 202, 202M, 204
Environmental Policy 200
Geography 102, 105, 140
History *110, *120, 204, *210, *220, *221, *230, *235, *241, *242, *245, *246, *250, *255, *260, *265, *275
Humanities 107
Journalism 100
Kinesiology *108, 211
Political Science 110, 210, 220, 230, *240, 250, 260
Psychology 101, *150, 251, 261, 265, 271
Sociology 101, *110, *120, 201, 202, 205, 210, 215, 230, 250
Women's and Gender Studies 101, 105, 107, *108, 115, 202, 204, *205, 206, 209, 250

E) Self-Development: 3 units minimum.

Take one course from the following:

Anthropology *205
Child Development *110
Counseling 200
Health Education 100, 101, 103, 105
Health Occupations 152
Kinesiology 104, *108
Psychology *150, 245
Reading 101
Sociology *110, *120
Women's and Gender Studies 103, *108, *205

* These courses appear in more than one category, but may be used only to satisfy one category.

+ May not be used for any regular (non-AAT/AST) AA degree. Please see a counselor for more information.

NOTE: Changes in the above General Education requirements may occur from time to time. If courses are added to or deleted from the pattern, this may affect a student's selection of courses. Students do not have catalog rights to a certification pattern, regardless of their continual attendance status.

CSU Transfer credit is noted in individual catalog course descriptions. A complete list of CSU transferable courses offered by Cerritos College can be found on the ASSIST website at www.assist.org.

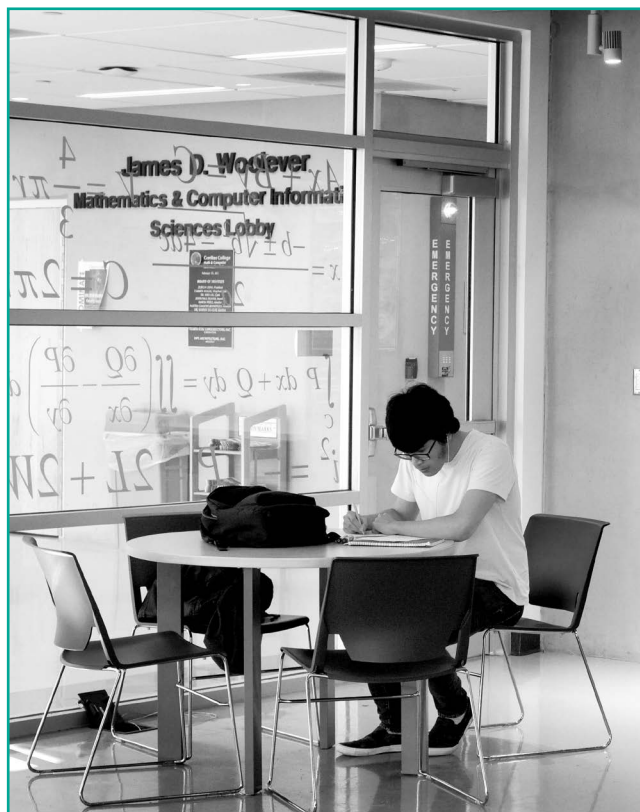

GENERAL EDUCATION REQUIREMENTS FOR THE ASSOCIATE DEGREE AND FOR TRANSFER TO THE CALIFORNIA STATE UNIVERSITY AND UNIVERSITY OF CALIFORNIA

Associate in Arts Degree General Education 2019-20 Plan C and/or The Intersegmental General Education Transfer Curriculum (IGETC) For Transfer To UC And CSU

Plan C is designed primarily for students who intend to transfer to the University of California (UC) or are undecided between transferring to the UC or the California State University (CSU). Students may use this plan to combine completion of both the A.A. Degree general education requirements and the IGETC General Education requirements.

The purpose of IGETC is to provide an option for students to fulfill lower division general education requirements prior to transferring to a UC or CSU campus.

Depending upon the student's major and campus choice, it may be advantageous to complete the requirements of the specific campus the student plans to attend. In general, it is not advisable for transfer students preparing for majors at any UC campus requiring a high number of units, such as engineering and science, to use IGETC.

Plan C can be fulfilled by completing the IGETC requirements specified for either the UC or CSU.

A letter grade of "C" or higher is required in all Plan C courses.

To earn an Associate in Arts degree using Plan C, students must complete a minimum of 60 degree applicable units with a grade point average of "C" (2.0) or higher, which must include the specified general education requirements and designated courses for a major. The Health and Wellness Proficiency requirement must be completed (see description in Plan A).

If a student wishes only to transfer and is not seeking an A.A. degree, they can follow the requirements below. There are no proficiencies required for IGETC certification.

It should be noted that completion of IGETC is not required for admission to the UC or CSU.

Further information and other regulations pertaining to IGETC and the Associate in Arts Degree are found in the catalog.

AREA 1 ENGLISH COMMUNICATION

CSU: Courses from A, B, and C required.

UC: Courses from A and B required.

- A) English Composition
(1 course, 3 semester/4-5 quarter units)
English 100, 100S

- B) Critical Thinking-English Composition
(1 course, 3 semester/4-5 quarter units)
Communication Studies 103
English 103, 110
Philosophy 103
Psychology 103
Reading 200
- C) Oral Communication (CSU ONLY)
(1 course, 3 semester/4-5 quarter units)
Communication Studies 100+, 120, 130, 132+

AREA 2 MATHEMATICAL CONCEPTS AND QUANTITATIVE REASONING

(1 course, 3 semester/4-5 quarter units)
Mathematics 112+, 114+, 115, 116+, 155+, 160+, 170+, 190, 225, 250
Psychology 210+

AREA 3 ARTS AND HUMANITIES

(3 courses, with at least one from A and one from B below;
9 semester/12-15 quarter units)

- A) Arts
Architecture 112
Art 100, 101, 102, 103, 104, 105A, 105B, 106, 107, *108, *109, 113, 118
Dance 100, 101
Film 159
Humanities *108, *109
Music 100, 101, 103, 104, 104B, 105, 180
Photography 160
Theatre 101, 102, 103, 104, 150
Women's and Gender Studies 118
- B) Humanities
American Sign Language 111, *220
Art *108, *109, 124, 125, 207
Chinese 102, 201, 202, 260
English 102, 106, 221A, 221B, 222, 223, 224, 225, 226, 227, 228, 230A, 230B, 232, 233, 234, 235, 236, 237, 238, 239, 245, 246A, 246B, 248A, 248B
French 201, 202, 281, 282, 283, 285+
German 102, 201, 202
History *101+, *102+, *103+, *110, *120, *210+, *230, *235, *241, *242, *245, *246, *250, *255, *260, *265, *275
Humanities 100, 107, *108, *109, 125
Japanese 102
Philosophy 100, 102, 104, 105, 107, 108, 109, 130, 140, 200, 201, 203, 204, 205, 206
Photography 150
Political Science *240
Spanish 102+, 112+, 201, 202, 205, 210, 245, 260, 285+
Women's and Gender Studies 102, 109, 207

GENERAL EDUCATION REQUIREMENTS FOR THE ASSOCIATE DEGREE AND FOR TRANSFER TO THE CALIFORNIA STATE UNIVERSITY AND UNIVERSITY OF CALIFORNIA

AREA 4 SOCIAL AND BEHAVIORAL SCIENCES

(3 courses from at least two disciplines or an interdisciplinary sequence: 9 semester/12-15 quarter units)

American Sign Language *220

Anthropology 100, 120, 170, 200, 201, 202, 203, 205, 206

Child Development 110

Communication Studies 110, 115

Economics 101+, 102, 201, 201M, 202, 202M

Environmental Policy 200

Geography 102, 105, 140

History *101+, *102+, *103+, *110, *120, 204, *210+, *230,

*235, *241, *242, *245, *246, *250, *255, *260, *265, *275

Humanities 107

Kinesiology 108

Political Science 101+, 201+, 210, 220, 230, *240

Psychology 101, 150, 251, 261, 265+, 271

Sociology 101, 110, 120, 201, 202+, 205, 210, 215, 250

Women's and Gender Studies 101, 105, 107, 108, 115, 202+, 204, 205, 206, 209, 250

c. Earn a minimum score of 500 on an appropriate College Board Achievement Test in a foreign language.

d. For other options, see your counselor.

B) CSU ONLY: The CSU has a specific American Institutions requirement that is separate from the general education requirements. Courses used to meet the American Institutions requirement may be used to satisfy requirements for the IGETC, at the discretion of the receiving CSU campus. It is recommended that this requirement be met prior to transfer. The following will meet the CSU American Institutions requirement.

6 units, one course from Group 1 and one course from Group 2.

Group 1: History 101+, 102+, 103+

Group 2: Political Science 101+, 201+

C) The UC-bound student should be aware of the American history and institutions requirements at the campus of choice. Requirements may vary. See your counselor for details.

+Credit limitation. UC credit limitations may apply for certain courses in IGETC, as well as other UC transferable courses which are not in IGETC. An explanation for each course, which has credit limitations, appears in the college catalog course description. For details, see your counselor.

AREA 5 PHYSICAL AND BIOLOGICAL SCIENCES

(2 courses, one from A and one from B below; at least one course must include laboratory (lab); 7-9 semester/9-12 quarter units)

A) Physical Sciences

Astronomy 102+, 103+, 104, 105L (lab) 106

Chemistry 100+ (lab), 110+ (lab), 111 (lab), 112 (lab)

Earth Science 101, 102 (lab), 104, 104L (lab), 106, 110+ (lab)

Geography 101, 101L (lab), 103

Geology 101 (lab), 102, 102L (lab), 103, 103L (lab), 201 (lab), 207 (lab), 208, 209

Physical Science 100+

Physics 100+ (lab), 101+ (lab), 102+ (lab), 201+ (lab), 202+ (lab), 203+ (lab)

B) Biological/Life Sciences

Anatomy and Physiology 120+ (lab), 150+ (lab), 151+ (lab), 200+ (lab), 201+ (lab)

Anthropology 115, 115L (lab)

Biology 115 (lab), 120+ (lab), 200 (lab), 201 (lab), 202

Botany 120 (lab)

Microbiology 200 (lab)

Psychology 241

Zoology 120 (lab)

* These courses appear in more than one category, but may be used only to satisfy one category.

ADDITIONAL REQUIREMENTS

A) UC ONLY: Language other than English

There are several ways to satisfy this requirement. They include:

- Complete two years of the same foreign language in high school with a grade of "C-" or higher.
- Complete first college course in any foreign language or ASL 110.



SERVICES FOR STUDENTS

The following pages describe the student services available at Cerritos College. We sincerely hope that you take the time to become familiar with these services and use them often to meet your goals at the college. The telephone extension of each service is listed. The college telephone number is (562) 860-2451.

ACCIDENT INSURANCE

EXT. 2321

Accident insurance is provided by Cerritos College to all enrolled students in the event of an accident or injury during college sponsored and supervised activities. The insurance **may** assist in covering medical bills incurred by students and athletes. There are benefit limitations and some exclusions in the policy, so it is important to work with the Student Health Services staff to insure optimum coverage. Students enrolled at Cerritos College, whose children are injured while using the officially designated childcare facility on campus, are covered by Accident Insurance.

ADMISSIONS AND RECORDS

EXT. 2211

The Admissions and Records Office has many functions. It is responsible for: application for admission, permanent records, transcript requests, student academic petitions, verification of student enrollment to appropriate institutions, and a segment of the enrollment procedure. Concerns should be directed to the Dean of Admissions, Records, and Services. Except during enrollment, the Admissions and Records Office hours are Monday through Thursday, 8 am – 7 pm; and Friday, 8 am – 2 pm. For additional information visit our website at www.cerritos.edu/admissions.

ASSESSMENT OFFICE

EXT. 2599

Assessment for Placement, or the Self-Report Tool (SRT) or Guided Placement Tool (GPT), is administered in the Assessment/Placement Office, located on the second floor of the Multipurpose Building. Results are used for advisement in selecting classes. Depending on when, where or if students attended high school, they will complete either the Self-Report Tool (SRT) or Guided Placement Tool (GPT), which, in most cases, will place students directly into transfer level courses in the areas of math and English or ESL. A current Cerritos College student number and photo ID are required to complete the SRT or GPT. Please visit our website at www.cerritos.edu/assessment-center for the current Placement schedule.

ATHLETICS

EXT. 2864

Cerritos College is a member of the South Coast Conference. Cerritos men's teams are represented in: baseball, basketball, cross country, football (SCFA), soccer, swimming, tennis, track and field, water polo and wrestling (SCWA). Cerritos women's teams are represented in: basketball, cross country, soccer, softball, swimming, tennis, track and field, volleyball, and water polo.

BOOKSTORE

EXT. 2462

The Cerritos College Bookstore is maintained by the Follett Higher Education Group in association with the ASCC. The store carries required materials, new and used textbooks, reference materials, school supplies, snacks, imprinted gifts, and clothing. MasterCard, Visa, American Express, and Discover are accepted. Fall and spring semester regular hours are: Monday through Thursday, 7:30 am – 7 pm and Friday, 7:30 am – 2 pm; closed on Saturday and Sunday.

CALWORKS

EXT. 2593

The Cerritos College CalWORKs Program assists students who are receiving cash aid assistance through the state of California's CalWORKs Welfare Program, are in good standing with the college, and have developed or are in the process of developing a welfare-to-work plan with the local welfare office. The program provides eligible students with the following support services: Academic, Career, Transfer, and Personal Counseling services; Priority Enrollment; one-on-one new student orientations; Basic Needs Assistance; math tutoring; computer lab; study rooms; workshops; scholarship opportunities; referrals to campus- and community-based organizations; and up-to-date information regarding welfare regulations, rules, and requirements. The staff advocates for students with the Department of Public Social Services (DPSS) in order to ensure that county, state, and federal regulations are administered fairly and correctly. For eligible students, the CalWORKs Office also provides a work-study program, which includes Career Guidance, assistance with resumé writing, mock interviewing skill building, Pre-Employment Preparation workshops (PEP), and subsidized paid work-study placements on campus. To make an appointment with a CalWORKs Counselor, please call (562) 860-2451, ext. 2593. The CalWORKs Office is located in the Santa Barbara Building. Our hours are Monday, Tuesday, Thursday, and Friday, 8 am – 4 pm; and Wednesday, 8 am – 6:30 pm. For additional information, please visit our website at www.cerritos.edu/calworks.

CAMPUS NEWS SERVICES AND SOCIAL MEDIA

EXT. 2618

To keep you abreast of news and interesting aspects of campus life, student publications are available to you free of charge. Produced by students in the Journalism Department, the award-winning weekly newspaper *Talon Marks* provides timely coverage of campus news and highlights, sports, and current events. Campus news is also available online at the Talon Marks website at www.talonmarks.com and on the campus radio station WPMD, or www.cerritos.edu/wpmd. These media, as well as the college itself, also provide news through Twitter, Facebook, and Instagram.

CAREER PLANNING

EXT. 2356

Career planning is available to individuals who are currently enrolled, who have graduated, or who hold certificates from Cerritos College. Career planning provides opportunities to explore career options, as well as the use of sophisticated computerized search programs including the Internet. Students are encouraged to take advantage of the skills, interests, and values inventories that are available to them in Career Services. A career counselor will assist you with understanding your assessment results and help you in choosing a career or major.

CAREER SERVICES

EXT. 2356

Career Services offers the following services to assist students in exploring and planning their academic and vocational futures: (1) Assessment Office, ext. 2599; (2) Career Planning, ext. 2356; (3) Student Employment Resources, ext. 2366; and (4) Re-entry Programs, ext. 2362. You may visit our website at www.cerritos.edu/career-services. Career Services hours are Monday and Thursday, 8 am – 4:30 pm; Tuesday and Wednesday, 8 am – 7 pm; and Friday, 8 am – 2 pm.

SERVICES FOR STUDENTS

CHILD DEVELOPMENT CENTER

EXT. 2583

The Cerritos College Child Development Center Program services students, college employees, and the community. The Center is also a laboratory school for future teachers in the field of Early Childhood Education. Our purpose is to provide a safe, nurturing, exceptional early childhood education program for children from 2 – 5 years old. Inspired by the schools of Reggio Emilia, Italy; we use a constructivist approach to learning. Cerritos College Child Development Center is open Monday through Friday, 7:30 am – 5 pm. We foster an emergent curriculum, one that arises out of the children's interests and responses to the prepared indoor and outdoor classroom environment and their experiences.

For students enrolled in courses at night, we have drop-in child care available for their children (ages 3 to 5 years), Monday through Thursday from 5:30 pm to 10 pm. Subsidized tuition is available to those that qualify. Students interested in the Night Care Program can contact the Child Development Center Office for registration information. Pre-registration is required.

Students interested in these services must contact the Child Development Center and fill out a Request for Child Development Services form, or call (562) 860-2451, ext. 2583.

COUNSELING

(562) 467-5231

Counselors are available in the Counseling Department to assist you with academic advisement, establishing realistic goals and devising a comprehensive student educational plan (C-SEP) to meet those goals. Counselors can keep you abreast of current requirements for your major. Counselors are available in person or virtually for appointments or standby/drop-in for quick questions. Online counseling is available at www.cerritos.edu/counseling. Counseling Department hours are Monday through Thursday, 8 am – 7 pm; and Friday, 8 am – 2 pm (excluding summer).

DISABLED STUDENT PROGRAMS AND SERVICES (DSPS)

EXT. 2335

Students with educational limitations due to a disability may receive accommodations and services from Disabled Student Programs and Services (DSPS). DSPS serves students with disabilities such as mobility, visual, hearing loss, psychological, learning, autism, and other health-related disabilities. DSPS has been in operation at Cerritos College since 1969. For more information or to schedule an appointment call (562) 860-2451, ext. 2335; (562) 274-7164 (VP); or visit our website at www.cerritos.edu/dsps.

EXTENDED OPPORTUNITY PROGRAMS AND SERVICES (EOPS)

EXT. 2398

Extended Opportunity Programs and Services (EOPS) assists low-income and educationally disadvantaged students in college. The program offers academic, personal, and career counseling; book grants; tutoring; early enrollment assistance; counseling courses; EOPS Summer Bridge program; school supplies; transfer assistance; and university tours. The EOPS Office is located on the south side of the Administration Building. Office hours are Monday through Thursday, 8 am – 7 pm; and Friday, 8 am – 2 pm. For more information, call (562) 860-2451, ext. 2398, or visit our website at www.cerritos.edu/eops.

FINANCIAL AID OFFICE

EXT. 2397

The Financial Aid Office offers grants, work-study opportunities, loans, and scholarships provided by federal and state governments and local agencies. The Free Application for Federal Student Aid (FAFSA) can be submitted at www.fafsa.gov, and the California Dream Act application can be submitted at www.caldreamact.org. The federal school code for Cerritos College is 001161. Financial Aid Office hours are Monday through Thursday, 8 am – 7 pm; and Friday, 8 am – 2 pm. For additional information, visit our website at www.cerritos.edu/finaid.

HEALTH INSURANCE

EXT. 2321

Supplemental insurance coverage programs are available for health and hospitalization coverage. Students interested should contact Student Health Services for insurance information and application.

HEALTH SERVICES

EXT. 2321

Health services are available to all students currently enrolled at Cerritos College upon proof of enrollment. First aid and referrals are available to all faculty, staff, and visitors. The Student Health Services is staffed by a group of professionals which include physicians, nurse practitioners, registered nurses, psychologists, medical assistants, and clerical support. They are all dedicated to your health and wellness. The SHS is able to provide basic outpatient services for the diagnosis and treatment of acute and sub-acute illnesses and injuries. A brief overview of services includes urgent care, preventive care, women's and men's health care; as well as, chiropractic services, referrals to psychological and optometric services, and a variety of support services (pharmacy, laboratory, health education, etc.). Accident, International student, and supplemental insurances are also available through the SHS. Office hours are currently Monday through Thursday, 8 am – 4:00 pm; and Friday, 8 am – 2 pm. We invite you to visit our website at www.cerritos.edu/shs, or call (562) 860-2451, ext. 2321. We are located on the southeast corner of campus and would like to extend an invitation for you to stop in and visit us anytime.

LEADERS INVOLVED IN CREATING CHANGE (LINC)

EXT. 2371

Leaders INvolved in Creating Change (LINC) is a support program designed to help link foster youth with support services on and off campus to ensure a successful transition from foster care to independent living. The goals of the program are to improve college access for current and former foster youth, increase retention and graduation rates, and promote student learning and development. Services provided to LINC students include academic counseling, early enrollment assistance (if eligible), tutoring, assistance with financial aid, and links to on-campus and off-campus resources. For more information call (562) 860-2451, ext. 2371, or visit www.cerritos.edu/linc.

LIBRARY AND LEARNING RESOURCE CENTER

EXT. 2430

The Wilford Michael Library and Learning Resource Center (LRC) is located near the center of campus. It provides a wide variety of services and materials.

The library is available for study and research. It contains more than 120,000 books and reference materials and over 100 print magazine and newspaper subscriptions. The library provides access to its online library catalog and thousands of magazine, journal, and newspaper articles in 70 online subscription databases through the library website on the Internet. Copy machines, printers, computers, ipads, and calculators are also available in the library for student use, and librarians are available for reference assistance.

The LRC houses the following services: Library (ext. 2430), Library Computer lab (ext. 2184), Media Services (ext. 2443), Distance Education (ext. 2405), Center for Teaching Excellence (ext. 2797), and Success Center (ext. 7891).

MENTAL WELLNESS PROGRAM

EXT. 2321

Psychological services, crisis intervention, and referrals are available to students experiencing emotional difficulties or concerns. Please contact Student Health Services at extension 2321 for assistance, or visit our website at www.cerritos.edu/shs.

SERVICES FOR STUDENTS

OFFICE OF INTERNATIONAL STUDENT SERVICES EXT.2133

The Office of International Student Services (OISS) fosters the education and development of F-1 Nonimmigrant students. The program provides eligible students with a comprehensive “One-Stop” approach with the following services: Admissions, Academic Counseling and Advising, early enrollment, small group orientations, welcome receptions advocacy regarding immigration requirements, computer lab, study rooms, and on-campus and community resources. The well-trained staff provides a welcoming and nurturing environment that assist new and continuing students to stay in federal program compliance and maintain good academic standing. The program provides workshops and support that assist students in adjusting to the American Culture and the California Community College educational system.

Cerritos College also offers a full-time Intensive English Program (IEP) to help develop English language skills. The IEP is a student-centered environment where students are fully immersed into the English language and culture. Upon successful completion, students can transition into their major field of study at Cerritos College and then transfer to the university of their choice.

To view the application for the *Academic* and/or *Intensive English Program* and **ALL** required documents, please visit our site at www.cerritos.edu/oiss, or call us at (562) 860-2451, ext. 2133. Our email address is oiss@cerritos.edu. The OISS office hours are Monday, Tuesday, Thursday, and Friday, 8 am – 4 pm; and Wednesday, 8 am – 6:30 pm. The OISS is located in the Santa Barbara Building.

PARKING EXT. 2325

All parking at Cerritos College is by permit only. Parking regulations are enforced 24 hours a day/ 7 days a week. A semester parking permit may be ordered online by logging into MyCerritos at <http://my.cerritos.edu> and clicking the link “Buy Parking Permit”. Permits may also be purchased on campus in the Admissions and Records Office during regular business hours and at Campus Police when Admissions and Records is closed, including weekends. A daily permit may be purchased from the ticket dispensers located in our student parking lots for \$2.00. In addition, Daily Permits can be purchased via [Park Mobile App](#). All permit dispensers accept dollar bills and coin currency, but do not give change or refunds of any kind. Credit cards are also accepted at all permit machines with a 25 cent convenience fee added to each transaction. Dispensers are located near the marquee in front of the gymnasium; on Falcon Way; and in student parking lots 1, 5, 6, 8, and 10. Timed parking stalls are also available and are located in lots 2, 6, and 8; these stalls require a pay and display permit which is valid for up to 2 hours. Parking in staff parking lots requires a current staff parking permit. Vehicles with a valid disabled “DP” placard or plate and a current and valid student or one-day permit are permitted to park in staff parking lots. “Blue Curb” and marked disabled parking stalls do not require a parking permit if a valid “DP” placard or plate is displayed in the vehicle (the registered owner of the “DP” placard must be present at all times when placard is being used on campus). Persons displaying a “DP” plate or placard may not park in parking stalls reserved for “Carpool” or “Board Members” at any time. Student parking is free the first week of each semester in any white-lined parking stall. Please note that the summer semester has 2 sessions and free parking is only given for the first week of the first session.

VEHICLES WITHOUT A PERMIT OR THAT ARE INCORRECTLY PARKED CAN BE ISSUED A PARKING CITATION. CERRITOS COLLEGE ASSUMES NO LIABILITY AND IS NOT RESPONSIBLE FOR DAMAGE TO OR THEFT OF ANY VEHICLE OR ITS CONTENTS. LOST OR STOLEN PARKING PERMITS ARE NOT REPLACED. PLEASE REFER TO THE COLLEGE CATALOG FOR ADDITIONAL PARKING INFORMATION.

RE-ENTRY RESOURCE PROGRAM EXT. 2362

The Re-entry Resource Program assists adults returning to school make a smooth transition, overcome barriers unique to returning adults, and successfully attain their college goals and objectives. Services include personal assistance, orientations, workshops based on re-entry student issues, support groups, information regarding child care, financial aid, career counseling, job placement, scholarship information, and community resources. The program

also coordinates the annual Mayor’s Exploration and Community Resources Fair. Re-entry students of varied ages find these services relevant to their needs and interests. The Re-entry Resource Program is located in Career Services. For more information, visit us at www.cerritos.edu/re-entry-program.

STUDENT EMPLOYMENT RESOURCES EXT. 2366

Cerritos College students and alumni who are seeking employment may review job listings in Career Services. Additional listings are accessible through the Internet. Assistance in seeking internships is also provided. Handouts on job search resources, resumé writing, and interviewing skills are available on request. Student Employment coordinates the bi-annual job fairs, Employer Business Panel, and on-campus employer information tables. For more information, call (562) 860-2451, ext. 2366; email student-employment@cerritos.edu; or visit us at www.cerritos.edu/job-placement.

SUCCESS CENTER EXT. 7891

The Success Center, located on the lower floor of the LRC, has been established to serve the needs of faculty and students across the campus. The Success Center provides learning assistance and academic support for students at all levels. Assistance in virtually any subject is available via workshops, directed learning activities, and computer software programs; as well as individually from qualified tutors and instructors. Faculty and staff in the Success Center involve instructors in developing supplemental instruction in a variety of forms and work with instructors to enhance course offerings. For hours, special schedules, and additional information; please call the Success Center at (562) 860-2451, ext. 7891, or visit the Center’s website at www.cerritos.edu/sc.

TRANSCRIPTS/VERIFICATION OF ENROLLMENT EXT. 2211

A transcript of all college work completed may be obtained by submitting a written request in the Admissions and Records Office. If ordered on campus, the first 2 transcripts (whether official or unofficial) and verifications of enrollment are free. For subsequent copies, a fee of \$3 is charged for each regular transcript; a \$10 fee is charged for each rush transcript requested at least 2 hours before closing. The fee for verification of enrollment is \$2 for three to five working days processing time, or \$7 for 24-hour service. Please contact the Admissions and Records Office by phone or check the website at www.cerritos.edu/, “MyCerritos”, “Transcripts”, for information on ordering transcripts via the web.

TRANSFER CENTER EXT. 2154

The Transfer Center offers information, referrals, and counseling services. The Transfer Center provides transfer events and workshops, general education information, advising appointments with university representatives, and university tours. The Transfer Center is located in the Administration Building West Quad. Office hours are Monday through Thursday, 8 am – 7 pm; and Friday, 8 am – 2 pm. Visit our website at www.cerritos.edu/transfer.

VETERANS’ EDUCATION OFFICE EXT. 3716

The Veterans’ Education Office is located in the Veterans’ Resource Center. The primary function of this office is to certify to the Veteran’s Administration that eligible veterans are enrolled at the college and pursuing an approved educational goal. Hours are Monday through Wednesday, 8 am – 7 pm; Thursday, 8 am – 5:30 pm; and closed on Friday.

VETERANS’ RESOURCE CENTER EXT. 3716

The Veterans’ Resource Center (VRC) is a one-stop center that houses certifying officials, veteran’s counselors, tutors, and other valuable resources. There are computers available for veteran students’ use and assistive technology for improved learning. Tutoring is available Monday through Wednesday, 8 am – 7 pm; and Thursday, 8 am – 5:30 pm. The VRC is located in the Student Center Complex. Hours are Monday through Wednesday, 8 am – 7 pm; Thursday, 8 am – 5:30 pm; and Friday, 8 am – 2 pm (excluding summer).

SERVICIOS PARA ESTUDIANTES

ADMISIONES Y REGISTRO

EXT. 2211

La oficina de Admisiones y Registro tiene muchas funciones. Es responsable por: solicitud de admisión, registros permanentes, peticiones de transcripción, peticiones académicas, verificación de matriculación de estudiantes para las instituciones pertinentes, y un segmento de el procedimiento de matriculación. Preguntas y comentarios pueden ser dirigidos al Decano de Admisiones y Servicios de Registro. Salvo en el tiempo de inscripción, el horario de la Oficina de Admisiones y Registro es Lunes a Jueves, 8 am – 7 pm; Viernes, 8 am – 2 pm. Para obtener información adicional, visite nuestro sitio de web en www.cerritos.edu/admissions.

OFICINA DE EVALUACIONES/COLOCACION EXT. 2599

La Evaluación para ubicación o la Herramienta de auto evaluación (SRT) son administradas en la Oficina de Evaluaciones que se encuentra en el segundo nivel del Edificio de usos múltiples. Los resultados se utilizan para la orientación en la selección de clases. Para los estudiantes que se graduaron de la escuela secundaria en los últimos 10 años, las certificaciones de una escuela secundaria de Estados Unidos se utilizan para ubicarlos en las clases de Lectura, Matemáticas o ESL. Los estudiantes que se graduaron de la escuela secundaria hace más de 10 años, que no hicieron o no completaron la escuela secundaria o que no tienen certificaciones de una escuela secundaria de Estados Unidos deben comunicarse con la Oficina de Evaluaciones para obtener las opciones apropiadas. Visite nuestro sitio web en www.cerritos.edu/assessment-center para ver el programa de Evaluaciones vigente.

LIBRERIA

EXT. 2462

La librería de Cerritos College es operada por el Grupo Follet Higher Education, en asociación con la ASCC. La tienda brinda materiales necesarios, libros nuevos y usados, materiales de referencia, útiles escolares, bocadillos, regalos y ropa impresa. Mastercard, Visa, American Express y Discover son aceptados. Las horas regulares de Otoño y Primavera son: 7:30 am a 7 pm, de Junes a Jueves; 7:30 am a 2 pm, Viernes; cerrado Sábados y Domingos.

CONSEJERIA

(562) 467-5231

Los consejeros están disponibles en el Departamento de Asesoramiento para ayudarle con asesoría académica, el establecimiento de metas realistas y la elaboración de un integral plan de educación para alcanzar esos objetivos. Consejeros pueden mantenerle al corriente de las necesidades actuales de su carrera. Los consejeros están disponibles por medio de citas de media hora o limitadamente sin cita para breves consultas. Consejería en línea está disponible en www.cerritos.edu/counseling. Los horarios del Centro de asesoría son Lunes a Jueves de 8 am a 7 pm; y el Viernes de 8 am a 2 pm (excluyendo verano).

PROGRAMAS Y SERVICIOS PARA ESTUDIANTES DISCAPACITADOS (DSPS)

EXT. 2335

Los estudiantes con limitaciones educativas debido a una discapacidad pueden recibir adaptaciones y servicios de los Programas y servicios para estudiantes discapacitados (DSPS). DSPS atiende a estudiantes con discapacidades como movilidad, visuales, pérdida de la audición, psicológicas, del aprendizaje, autismo y otras discapacidades relacionadas con la salud. DSPS ha estado funcionando en Cerritos College desde 1969. Para obtener más información o para programar una cita llame al (562) 860-2451, ext. 2335; (562) 274-7164 (VP); o visite nuestro sitio web en www.cerritos.edu/dsps.

OFICINA DE AYUDA FINANCIERA

EXT. 2397

La Oficina de Ayuda Financiera ofrece becas, trabajo y oportunidades de estudio, préstamos y becas otorgadas por los gobiernos federales y estatales y agencias locales. La Solicitud Gratuita de Ayuda Federal para Estudiantes (FAFSA) puede llenarse en la web en www.fafsa.gov, y la solicitud de California Dream Act se puede enviar a www.caldreamact.org. El código de Cerritos College es 001161. El horario de la Oficina de Ayuda Financiera es Lunes a Jueves, 8 am – 7 pm; Viernes, 8 am – 2 pm. Para obtener información adicional, visite nuestro sitio web en www.cerritos.edu/finaid.

ESTACIONAMIENTO

EXT. 2325

El estacionamiento en Cerritos College es únicamente con permiso. Las regulaciones de estacionamiento se deben cumplir las 24 horas del día, los 7 días de la semana. Se puede solicitar un permiso de estacionamiento semestral por Internet. Para hacerlo, regístrese en MyCerritos en y haga clic en el enlace “Buy Parking Permit” (Comprar permiso de estacionamiento). También se pueden comprar permisos en el campus, en la Oficina de Admisiones y Registros (Admissions and Records Office) durante el horario normal de atención, y en la Policía del Campus (Campus Police) cuando la Oficina de Admisiones y Registros esté cerrada, incluso los fines de semana. Se pueden comprar permisos por día, por \$2, en los dispensadores de boletos ubicados en nuestros estacionamientos para estudiantes. Todas las expendedoras de permisos aceptan billetes de dólar y monedas, pero no dan cambio ni reembolsos de ningún tipo. Todas las máquinas de permisos además aceptan tarjetas de crédito con una tarifa de 25 centavos por el servicio que se suma a cada transacción. Los dispensadores se encuentran cerca de la marquesina frente al gimnasio, en Falcon Way, y en los estacionamientos para estudiantes 1, 5, 6, 8 y 10. Los lugares de estacionamiento por tiempo también se encuentran disponibles en los estacionamientos 2, 6 y 8. Estos lugares requieren del pago y de la exhibición del permiso que es válido por hasta 2 horas. El estacionamiento en lugares reservados para el personal requiere un permiso vigente. Se permite que los vehículos con un cartel o una placa válida por discapacidad “DP” (persona discapacitada, por sus siglas en inglés), y un permiso por un día vigente y válido para estudiantes, estacionen en estacionamientos para el personal. La “acera de color azul” y los lugares de estacionamiento marcados para discapacitados no requieren un permiso de estacionamiento, si el vehículo tiene un cartel o una placa válida de “DP” (el dueño registrado del cartel de “DP” debe estar presente en todo momento cuando se use el cartel en el campus). Las personas que exhiban una placa o un cartel de “DP” no pueden estacionar en ningún momento en aquellos lugares de estacionamiento reservados para “personas que comparten el vehículo” o “miembros de la junta”. El estacionamiento para alumnos es gratuito durante la primera semana de cada semestre en cualquier espacio de estacionamiento marcado con líneas blancas. Tenga en cuenta que el semestre de verano tiene 2 sesiones y que el estacionamiento es gratuito únicamente durante la primera semana de la primera sesión.

SE PUEDE EMITIR UNA CITACIÓN DE ESTACIONAMIENTO A AQUELLOS VEHÍCULOS SIN UN PERMISO O QUE ESTÉN ESTACIONADOS DE FORMA INCORRECTA. CERRITOS COLLEGE NO ASUME NINGUNA RESPONSABILIDAD NI TAMPOCO ES RESPONSABLE DEL DAÑO O ROBO DE NINGÚN VEHÍCULO NI SUS CONTENIDOS. NO SE REEMPLAZAN LOS PERMISOS DE ESTACIONAMIENTO PERDIDOS O ROBADOS. CONSULTE EL CATÁLOGO DE LA UNIVERSIDAD SI DESEA OBTENER INFORMACIÓN

If you have questions or need information in Spanish about Cerritos College, please call the Admissions and Records Office at (562) 860-2451, extension 2211. Office hours are Monday through Thursday, 8 am – 7 pm; Friday, 8 am – 2 pm. Additional information is available in Spanish on pages 10-14.

Si usted tiene preguntas o necesita información en español acerca del Colegio de Cerritos, llame por favor a la Oficina de Admisiones y Registro al número (562) 860-2451, extensión 2211. El horario de oficina es Lunes a Jueves, 8 am – 7 pm; Viernes, 8 am – 2 pm. Información adicional está disponible en español en las páginas 10-14.

DISABLED STUDENT PROGRAMS AND SERVICES

Students with educational limitations due to a disability may receive accommodations and services from Disabled Student Programs and Services (DSPS). DSPS serves students with disabilities such as mobility, visual, hearing loss, psychological, learning, autism, and other health-related disabilities. Students who wish to apply for DSPS services should come to the Liberal Arts/DSPS building to pick up a New Student Application. For further information, contact DSPS at (562) 860-2451, ext. 2335; (562) 274-7164 (VP); or visit our website at <https://www.cerritos.edu/dsps/>.

DSPS Services:

DSPS determines reasonable accommodations on a case by case basis by reviewing the disability verification documentation and engaging in an interactive process with each student. Following are some of the supportive services which may be approved as reasonable accommodations, depending on the nature of the student's educational limitations, to assure access to educational activities at Cerritos College:

- *Notetakers*
- *Testing accommodations*
- *Materials in alternate format*
- *Assistive Technology*
- *Sign language interpreters*
- *Assistive listening devices*
- *Priority enrollment*
- *Academic adjustments*

Additional services available through DSPS may include:

- *Counseling*
- *Enrollment assistance*
- *Illness notification*
- *Instructor liaison*
- *Assistive technology training*



Disabled Student Programs and Services is located in the Liberal Arts/DSPS Building.

Instructional Offerings:

Access Learning Courses

ACLR 86 – Introduction to Universal Design for Learning – 2.0 units

ACLR 87 – Using Scan-Read Technologies in Universal Design for Learning – 2.0 units

ACLR 91 – Career Exploration for Students with Disabilities – 1.0 unit

ACLR 101 – Increasing Your Access Potential – 2.0 units

Adapted Physical Education Courses

PEX 100 – Fitness for Students with Disabilities – 1.0 unit

PEX 100A – Adapted Independent Exercise – 1.0 unit

PEX 101 – Wheelchair Activities – 1.0 unit

PEX 102 – Adapted Cardiovascular Exercise – 1.0 unit

PEX 103 – Adapted Strength Training – 1.0 unit

PEX 130 A – Adapted Circuit Weight Training – 1.0 unit

PEX 104 – Adapted Stretching and Relaxation – 1.0 unit

PEX 105 – Adapted Swimming – 1.0 unit

PEX 106 – Adapted Aquatic Exercise – 1.0 unit

PEX 106A – Adapted Aquatic Group Fitness – 1.0 unit

PEX 107 – Adapted Team Sports – 1.0 unit

PEX 107A – Adapted Soccer – 1.0 unit

PEX 108 – Adapted Individual Sports – 1.0 unit

PEX 109 – Adapted Group Fitness – 1.0 unit

DANC 102 – Introduction to Adaptive Dance – 2.0 units

In accordance with the Americans with Disabilities Act, this information is available in alternate formats (Braille, enlarged type, e-text, etc.) and may be requested by calling (562) 860-2451, Ext. 2335.

SUCCESS CENTER

Do you need tutoring for any of your Cerritos College courses? Do you need help managing your time efficiently? Do you need to learn how to take good lecture notes or learn how to better study from your textbook? Do you need help dealing with the stress of going to college? The Success Center can provide the answers and the help that you're looking for. All Cerritos College students may attend any of the free services listed below. Visit the Success Center, located in the LRC, for more information or visit the Center's website at www.cerritos.edu/sc.

Individualized Instruction from Faculty

Faculty members are available at various times for assistance in math, English, English as a Second Language, and reading.

Technology Training & Computer Proficiency

Training sessions are offered in word processing, spreadsheets, multimedia presentations, MyFoundationsLab, Canvas, etc.

Support for Online Students

Walk-in support for online students
Online tutoring
Online FAQ's

Tutorial Services

Walk-in math & English tutoring
Tutoring by appointment in other subjects
Smarthinking Online Tutoring

Workshops

Workshops in various topics such as, How to Read Your Textbook, How to Take Great Notes, Stress Management, Student Success, and many more!



STUDENT SERVICES AND POLICIES

ASSOCIATED STUDENTS

The Associated Students of Cerritos College (ASCC) provides the governing body that finances, organizes, and directs many programs for the student population. It co-sponsors with the district such activities as touchtone registration, athletics, choir, band, forensics, drama, and the student newspaper. Students are encouraged to participate in campus clubs and organizations. The club program is an ever-growing phase of campus life, with new clubs forming every year. With more than 60 clubs, students are provided the opportunity to become involved in curricular, special interest, and social programs. The Inter-Club Council meets regularly to give all clubs and organizations the chance to share their activities collectively. For additional information about the ASCC and campus clubs, please stop by the Office of Student Affairs, or call (562) 860-2451, ext. 2458.

STATEMENT OF STUDENT RIGHTS AND RESPONSIBILITIES PREAMBLE

The community college exists for the transmission of knowledge, the pursuit of truth, the development of students, and the general well-being of society. Free inquiry and free expression are indispensable to the attainment of these goals. As members of the academic community, students should be encouraged to develop the capacity for critical judgment and to engage in a sustained and independent search for truth and knowledge.

Freedom to teach and freedom to learn are inseparable facets of academic freedom. The freedom to learn depends upon appropriate opportunities and conditions in the classroom, on the campus, and in the larger community. Students should exercise their freedom with responsibility so as not to endanger the rights, goals, and beliefs of other students.

Cerritos College is open to all qualified students regardless of national origin, religion, age, gender, gender identity, gender expression, race or ethnicity, color, medical condition, genetic information, ancestry, sexual orientation, marital status, physical or mental disability, pregnancy, or because he or she is perceived to have one or more of the foregoing characteristics, or based on association with a person or group with one or more of these actual or perceived characteristics, or any other status protected by law in person or in an online environment and, when the victim or victims are associated with the District, whether or not the location is associated with the District.

CLASSROOM RIGHTS AND RESPONSIBILITIES

The professor in the classroom and in conference should permit free discussion, inquiry, and expression of thought by the student. Student performance should be evaluated solely on an academic basis, not on opinions or willingness to accept professors' personal beliefs, or conduct unrelated to academic standards. Students should be free to take reasoned exception to the data or views offered in any course of study for which they are enrolled and for maintaining standards of academic performance established for each course in which they are enrolled. The student has the right to have the course taught in a systematic, meaningful manner and to know at the beginning of the course those academic standards required of the student in the course.

Administrative staff and faculty members should respect confidential information about students, such as student views, beliefs, and political associations, that is acquired in the course of their work. Transcripts of academic records should contain only information about academic status.

ON THE CAMPUS RIGHTS AND RESPONSIBILITIES

Students should be free to examine and discuss all questions of interest to them, and express opinions publicly and privately. They should be

free to organize and join associations to promote their common interests. The membership, policies, and actions of a student organization will be determined by vote of only those persons who hold bona fide membership in that college organization. Campus advisors shall advise organizations in the exercise of their rights and responsibilities.

Student organizations shall be required to submit a statement of purpose, criteria for membership, rules of procedures, a current list of officers, and the advisor shall certify the list of verified members. Campus organizations should be open to all students.

Students and student organizations should be free to support causes by orderly means which do not disrupt the regular and essential operation of the college. Student organizations shall have the right to recommend, invite, and hear any person of their own choosing as long as such speakers and topics are in accordance with federal, state, and local laws, and guarantee the safety of students and protection of public property. Guest speakers invited by students or student organizations should be subjected only to those policies, requirements, and regulations as established by the Board of Trustees in order to insure an appropriate and meaningful contribution to the academic community. It should be made clear to the academic community and the larger community that the public expressions of students, student organizations, and guest speakers speak only for themselves.

As constituents of the academic community, students should be free, individually and collectively, to express their views on issues of institutional policy, instruction, the evaluation of professors as it pertains to their course content, and on matters of general interest to the student body.

IN THE LARGER COMMUNITY

College students are both citizens and members of the academic community. As citizens, students should enjoy the same freedom of speech, peaceful assembly, and right of petition that other citizens enjoy. As citizens, they should be subject to civil law as others and may incur penalties prescribed by civil authorities when violating these laws. Only where the college's interest as an academic community are distinct and clearly involved should the special authority of the college be asserted.

STUDENT PUBLICATIONS

Student publications and the student press perform the traditional roles of informing, entertaining, and influencing. They are both instructional and informational, and as such should meet the highest academic and professional standards in serving the broad college community and should set forth as the primary goal of the student newspaper the coverage of news events, happenings, and experiences on the college campus.

Associated Student Body, administrative and academic authorities, in consultation with students and advisors have the responsibility to define and clarify the role of student publications, and the standards to be used in their evaluation.

They must also assure that both academic freedom and editorial freedom are protected and exercised so that the integrity of the student publications program and the free press will not be compromised.

It is incumbent upon student editors and managers to act according to the highest ethics of responsible journalism. This corollary responsibility includes careful adherence to the laws of libel and good taste, and such considerations as the avoidance of indecency, undocumented allegations, attacks on personal integrity, and the techniques of harassment and innuendo, and should allow adequate space for rebuttal and differing views in regard to articles in which there is some controversy.

STUDENT SERVICES AND POLICIES

Safeguards to assure freedom of the student press with responsibility should include freedom from censorship or arbitrary control of the press, and protection of editors and managers from arbitrary attack, suspension, or removal because of disapproval of editorial policy or content by any external influence.

STUDENT RIGHTS AND GRIEVANCES

Note: Complaints under Section 504, Section 508, and/or the Americans with Disabilities Act are to be made to the Section 504/508/ADA Coordinator in the Disabled Student Programs and Services Office or to the Diversity/Compliance/Title IX Officer in the Human Resources Office. Complaints of sexual harassment and other illegal discrimination are to be made to the Diversity/Compliance/Title IX Officer in the Human Resources Office or the Vice President of Human Resources.

If a student files a grievance under this procedure that includes an allegation of unlawful discrimination, including harassment or retaliation, the grievance, or portion of the grievance, will immediately be referred to: (i) the Diversity/Compliance/Title IX Officer or to the Vice President of Human Resources or designee per AP 3435, "Intake and Processing of the Complaint"; or to (ii) the Cerritos College Section 504/ADA Coordinator per Administrative Procedure 3412, for attempted informal resolution or investigation.

STUDENT GRIEVANCE PROCEDURES

A student of the College may address grievances as applied to and regarding academic, administrative, and instructional matters relating to students, and including, but not limited to, any grievance dealing with any academic or management employee of the District.

A grievance shall herein be defined as any act depriving a student of any of the rights set forth in the statement of "Student Rights and Responsibilities," or any state, federal, or local codes. Grades and grading grievances are not addressed within this administrative procedure. The student should refer to "Student Grade Grievance Procedure."

The determination of whether the Statement of Grievance presents sufficient grounds for a hearing shall be based on the following:

- The statement contains facts which, if true, would constitute a grievance under these procedures;
- The grievant is a student, which includes applicants and former students;
- The grievant is personally and directly affected by the alleged grievance;
- The grievance was filed in a timely manner;
- The grievance is not clearly frivolous, clearly without foundation, or clearly filed for purposes of harassment.

If the grievance does not meet each of the requirements, the Office of Student Conduct and Grievance or ASCC Chief Justice or designee shall notify the student in writing of the rejection of the request for a grievance hearing, together with the specific reasons for the rejection and the procedures for appeal.

GRIEVANCE PROCEDURE (EXCEPT GRADES AND GRADING, SEXUAL HARASSMENT, AND OTHER ILLEGAL DISCRIMINATION):

STEP I - INFORMAL ACTION

- A. The student with a grievance shall first attempt to resolve the matter by informal discussion with the employee(s) involved.
- B. If the problem is not resolved in step I-A, the student shall then attempt to resolve the matter by informal discussion with

the person at the lowest level of supervisory authority for the person with whom there is a complaint.

- C. If the grievant still believes the issue has not been resolved satisfactorily after Step I-B, a student Statement of Grievance Form may be obtained from the Office of Student Conduct and Grievance. After completion of the Form specifying the time, place, nature of the complaint, and remedy or correction requested; it should be submitted to the Coordinator of Student Conduct and Grievance who will send a copy of the written statement to the ASCC Supreme Court Chief Justice and the Vice President of Academic Affairs. This statement must be submitted within 30 instructional days after the grievant has become aware of the act or condition on which the complaint is based. An instructional day is defined as any day Monday through Friday that all normal college business is conducted, both in the classroom and administrative offices. All weekend days and college holidays are excluded.
- D. The ASCC Chief Justice or Court designee shall attempt to resolve the problem through informal meeting and discussion among the pertinent parties while remaining neutral on all issues involved. This informal meeting and discussion is intended to include the levels of management or administration concerned with the problem and should be completed within ten instructional days, as such days are defined herein. In the event the informal procedure fails, the formal procedure may be implemented.

STEP II - FORMAL ACTION

A. PRELIMINARY STEPS

1. If the grievant does not believe the grievance has been resolved, the grievant may request Step II-Formal Action through the ASCC Chief Justice. The Chief Justice upon receiving the request of the grievant shall call a meeting of the Student Grievance Hearing Committee. The Hearing Committee will be composed in the following manner:
 - ASCC Chief Justice or designee and two Court Justices or designees,
 - the Vice President of Academic Affairs or administrative designee,
 - the Faculty Senate President or Senate designee, and
 - one Faculty Senate member, chosen by the Faculty Senate.

If replaced per section II.A.5. herein, the ASCC Chief Justice or designee or Court Justices or designees substitute(s) shall be appointed by the ASCC Court.

2. The Chief Justice or designee shall serve as the Hearing Committee Chair, but shall have no vote in committee decisions. The five voting members of the Hearing Committee may be selected within the first six weeks of the academic year. Names selected by the Faculty Senate are to be submitted to the Chief Justice. Members of the Committee are to serve for an academic year.
3. The Vice President of Academic Affairs or administrative designee shall serve as Hearing Committee Executive Secretary. The Executive Secretary, a voting member of the committee, shall be responsible for keeping necessary records of committee hearings and assist the ASCC Chief Justice in the conduct of the hearing.
4. Grievance Committee members are to deal with all grievances in a confidential manner, except when both parties agree to a public hearing or otherwise required by law.

STUDENT SERVICES AND POLICIES

5. No person shall serve as a member of a Hearing Committee if that person has been personally involved in any matter giving rise to the grievance, has made any statement on the matters at issue, or could otherwise not act in a neutral manner. Any party to the grievance may challenge for cause any member of the hearing committee prior to the beginning of the hearing by addressing a challenge to the Hearing Committee Chair, who shall determine whether cause for disqualification has been shown. If the Hearing Committee Chair determines that sufficient grounds for removal of a member of the committee have been presented, the Hearing Committee Chair shall remove the challenged member or members and request a substitute from the original appointing constituent group.
- B. FORMAL HEARING
- The Hearing Committee shall conduct its proceedings according to the following procedures:
1. The Hearing Committee must meet within 15 instructional days after informal action has been completed and the grievant has requested a formal hearing.
 2. The Chair must notify the parties involved within five instructional days before the hearing of the date, time, and location of the hearing and must include a copy of the written complaint, a copy of the Statement of Student Rights and Responsibilities, and copy of the Grievance Procedure.
 3. Four members shall constitute a quorum by which Hearing Committee business may proceed. The quorum must include at least one student member, one faculty member, and one administrative member.
 4. The members of the Hearing Committee shall be provided with a copy of the grievance and any written response provided by the respondent before the hearing begins.
 5. Both parties shall have the right to present personal statements, testimony, evidence, and witnesses. Formal rules of evidence shall not apply. Any relevant evidence shall be admitted. Unless the Hearing Committee determines to proceed otherwise, each party to the grievance shall be permitted to make an opening statement. Thereafter, the grievant or grievants shall make the first presentation, followed by the respondent or respondents. The grievant(s) may present rebuttal evidence after the respondent(s)' evidence. The burden shall be on the grievant or grievants to prove by substantial evidence that the facts alleged are true.
 6. Each party shall have the right to be present, to be accompanied by the person of his or her choice (who may not participate in the hearing), and to question witnesses who are present. In a closed hearing, witnesses shall not be present at the hearing when not testifying, unless all parties and the committee agree to the contrary.
 7. The hearing shall be recorded by the Coordinator of Student Conduct and Grievance, either by audio recording or stenographic recording, and shall be the only recording made. No witness who refuses to be recorded may be permitted to give testimony. The audio or stenographic recording shall remain in the custody of the District, at all times, unless released to a professional transcribing service. Any recognized party to the grievance may request a copy of the recording.
 8. The Hearing Committee Chair shall, at the beginning of the hearing, ask each person present to identify themselves by name, and thereafter shall ask witnesses to identify themselves by name.
 9. The Hearing Committee shall discuss the stated grievance(s), hear testimony, examine witnesses, and receive all available evidence to the charge.
 10. The hearing shall be closed to the public unless otherwise agreed upon in writing by both parties.
 11. The Hearing Committee shall make decisions in private. The Hearing Committee shall write up findings and decisions. Copies of findings and decisions, including majority and minority reports, are to be sent to each party and the appropriate Vice President. The Hearing Committee's decision(s) shall be final unless appealed.
 12. A recording of the proceedings shall be kept in a confidential file in the Office of Student Conduct and Grievance and shall be available at all times to parties directly involved. All documents, communications, and records dealing with the processing of a grievance will be filed separately from the personnel files of the participants. After a period of four years, the grievance file shall be destroyed.
 13. Reprisals of any kind will not be taken by the District or any of its agents against any party of interest or any other participant in the grievance procedure by reason of such participation.
 14. Evidence and testimony given in each case presented shall not be the sole cause of initiating or filing further grievances.
 15. If the grievant does not act within the time limits provided herein, the ability to proceed with the grievance shall be terminated and no further action will be taken.
 16. The number of instructional days indicated at each step herein should be considered a maximum and every effort must be made to expedite the process. Time limits may be extended by mutual consent in writing or by decision of the Hearing Committee.
 17. The Hearing Committee should attempt to reach a decision by discussion and consensus on a workable solution. Voting should be a last course of action.
 18. If in the course of the proceedings a student graduates before a solution is found, the student shall not be denied full consideration under this policy. A student may also submit a grievance after graduation if the grievance did not become known until that time. However, it must be submitted within 30 instructional days after the grievant should have reasonably become aware of the act or condition on which the complaint is based.
- APPEALS PROCESS**
1. If a party wishes to formally appeal a recommendation of the Hearing Committee, an appeal must be submitted within ten instructional days to the appropriate Vice President provided the appropriate Vice President is not a direct party to the grievance. If the appropriate Vice President is a direct party to the grievance, and either party is dissatisfied with the recommendation of the Hearing Committee, an appeal may be submitted to a Vice President/Assistant Superintendent not a direct party to the grievance.

STUDENT SERVICES AND POLICIES

2. Upon receiving the findings and recommendations of the Hearing Committee, and after examination of the appeal as requested by either party, the appropriate Vice President or alternate may accept or reject the Hearing Committee's decision.
3. If the appropriate Vice President or alternate rejects the Hearing Committee's decision, he or she shall submit his/her decision with the stated reasons for objections to the Hearing Committee within ten instructional days. The Hearing Committee shall within ten instructional days reconsider its decision(s) and submit its decisions to the appropriate Vice President for a final decision.
4. The appropriate Vice President shall transmit his or her final decision to the parties within ten instructional days.
5. An appeal of the appropriate Vice President's decision may be submitted to the President/Superintendent by either party within five instructional days of the appropriate Vice President's decision. The President/Superintendent shall transmit his or her final decision to the parties within ten instructional days.
6. An appeal of the President/Superintendent's decision may be submitted to the Board of Trustees by either party within five instructional days of the President/Superintendent's decision. The Board of Trustees may review an appeal for two consecutive regular Board meetings before making a final determination of the matter at the District level.
7. The President/Superintendent or designee, or the Board of Trustees may reject a Hearing Committee decision only after reviewing a transcription of the involved hearing.

STUDENT GRADE GRIEVANCE PROCEDURE

A student of the College may present a grade grievance. The California Education Code, Section 76224, quoted, states for a final course grade the conditions upon which grades or grading can be questioned.

"When grades are given for any courses of instruction taught in a community college district, the grade given to each student shall be determined by the instructor of the course and the determination of the student's grade by the instructor, in the absence of mistake, fraud, bad faith, or incompetence, shall be final." "Mistake" may include, but is not limited to, errors made by an instructor in calculating a student's grade and clerical errors.

Definitions

Fraud – Fraud consists of some deceitful practice with intent to deprive another of their right.

Bad Faith – Intentional design to mislead or deceive another, or neglect or refusal to fulfill some duty or contractual obligation.

Incompetence – That a person is incapable, inefficient, and without the qualities needed to discharge their obligations and duties.

Mistake – An unintentional act, omission, or error.

Instructional Day - Any day Monday through Friday that all normal college business is conducted, both in the classroom and in the administrative offices. All weekend days and college holidays are excluded.

STEP I – INDIVIDUAL ACTION

If a student believes they have valid grounds to challenge a final course grade based on the presence of a mistake, fraud, bad faith, or incompetence, they must first meet with the faculty member to attempt to resolve his or her concern informally. Once grades are available, the student is expected to contact their instructor directly to discuss the dispute. If the instructor is not available or is no longer employed, the student should contact the Division Dean.

When challenging a grade, the burden of proof is on the student to provide evidence of mistake, fraud, bad faith, or incompetence.

STEP II – MANAGEMENT ACTION

Note: If a student files a grade grievance that includes an allegation of unlawful discrimination, including harassment or retaliation, the grievance, or portion of the grievance, will immediately be referred to (i) the Diversity/Compliance/Title IX Officer or to the Vice President of Human Resources or designee per AP 3435, "Intake and Processing of the Complaint" or to (ii) the Cerritos College Section 504/ADA Coordinator per AP 3412, for attempted informal resolution or investigation.

1. The student will submit the Grade Grievance Form on the Office of Student Conduct and Grievance website within 30 instructional days after the completion of the course about which the grade grievance is filed. Information from the form will be used to create a Grade Grievance Petition, provided to the student during the meeting with the Student Conduct Coordinator. Students may obtain an alternate electronic format of this form by request to the Student Conduct Coordinator or Dean of Student Services. Stated deadline still applies.
2. The Student Conduct Coordinator will meet with the student to review this procedure and the Grade Grievance Petition. The student must schedule and meet with the Student Conduct Coordinator within 10 instructional days of submitting the form. If the student wishes to pursue the grievance, the Student Conduct Coordinator will sign and date the Petition and provide to the student. In the absence of the Coordinator, the Dean of Student Services will perform these duties.
3. The student will present a copy of the Grade Grievance Petition and all supporting evidence to the applicable Division Dean within 10 instructional days of obtaining the signature of the Student Conduct Coordinator. The Division Dean may schedule a meeting with the student and the faculty if appropriate. The Division Dean shall render a decision, and communicate the decision in writing to all parties within 15 instructional days. The outcome notice must include a summary of the grievance allegations, findings from review of the grievance and supporting evidence, a statement of analysis and determination, and instructions for appeal.

STEP III – ADMINISTRATIVE ACTION

If either party is dissatisfied with the decision of the Division Dean, he or she may appeal the matter to the Vice President of Academic Affairs or designee within ten instructional days of the Division Dean's recommendation. The Vice President of Academic Affairs or designee shall call a meeting with the student, the ASCC Chief Justice, the Division Dean, and if needed, the faculty member. The Vice President of Academic Affairs or designee shall transmit his or her decision to the parties within ten instructional days.

The outcome notice must include a summary of the grievance allegations and prior findings, findings from review of the grievance appeal and supporting evidence, a statement of analysis and determination, and instructions for appeal.

STUDENT SERVICES AND POLICIES

STEP IV – BOARD OF TRUSTEES ACTION

If either party is dissatisfied with the decision of the Vice President of Academic Affairs or designee, an appeal may be submitted to the Board of Trustees. The appeal must be submitted within ten instructional days of the Vice President of Academic Affairs or designee's decision. The Board may review an appeal for two consecutive regular Board meetings during closed session, and if needed, request persons involved in the grievance to appear before making a final determination of the matter at the District level. Following final determination, the outcome will be recorded in the Board minutes and notice provided to all parties in writing from the Office of the President within ten instructional days. The outcome notice must include a summary of the grievance allegations and prior findings, findings from review of the grievance appeal and supporting evidence, and the statement of final determination.

Any times specified in these procedures may be shortened or lengthened if there is mutual concurrence by all parties.

ADDITIONAL INFORMATION

Most complaints, grievances, and disciplinary matters should be resolved at the college level. If a complaint does not fall into one of the college's established procedures, it may be addressed in writing to the President/Superintendent. Individuals are strongly encouraged to make every attempt to resolve matters through the appropriate administrative processes.

Matters that are not resolved at the college level may be submitted to one or more of the following agencies for consideration:

- The Accrediting Commission for Community and Junior Colleges (ACCJC) at <http://www.accjc.org/complaint-process>, if the complaint is associated with the institution's compliance with academic program quality and accrediting standards. The ACCJC is the agency that accredits the academic programs of the California Community Colleges.
- If the complaint does not concern the college's compliance with academic program quality and accrediting standards, it may be directed to the California Community Colleges Chancellor's Office by completing the web form found at <http://californiacommunitycolleges.cccco.edu>.

STANDARDS OF STUDENT CONDUCT

The President/Superintendent shall establish procedures for the imposition of discipline on students in accordance with the requirements for due process of the state and federal laws and regulations.

The procedures shall clearly define the conduct that is subject to discipline, and shall identify potential disciplinary actions, including but not limited to the removal, suspension, or expulsion of a student.

A complainant or witness who participates in an investigation of sexual assault, domestic violence, dating violence, or stalking will not be subject to disciplinary sanctions for a violation of the District's student conduct policy at or near the time of the incident, unless the District determines that the violation was egregious, including but not limited to, an action that places the health or safety of any other person at risk or involves plagiarism, cheating, or academic honesty.

Due process requires that in all significant disciplinary situations a student is informed of charges against him/her, is given an opportunity to refute them, and has the opportunity to appeal a decision.

The Board of Trustees shall consider any recommendation from the President/Superintendent for expulsion. The Board of Trustees shall consider an expulsion recommendation in closed session unless the student requests that the matter be considered in a public meeting. Final action by the Board of Trustees on the expulsion shall be taken at a public meeting.

The procedures shall be made widely available to students through the College catalog and other means.

Students enrolling in Cerritos College assume an obligation to abide by all District regulations on District-owned or controlled property or at District-sponsored or supervised functions.

Students who fail to adhere to District regulations are subject to disciplinary actions.

In all disciplinary actions, the student shall be informed of the nature of the charges against him/her and given a fair opportunity to refute them. The District shall not be arbitrary in its actions.

The following conduct while on District-owned or controlled property or at District-sponsored or supervised functions shall constitute good cause for discipline, including but not limited to the removal, suspension, or expulsion of a student.

1. Assault, battery, or any threat of force or violence, or causing, attempting to cause, or threatening to cause physical injury to another person, in person or in an online environment and, when the victim or victims are associated with the District, whether or not the location is associated with the District.
2. Possession, use, sale, or otherwise furnishing any firearm, knife, explosive, or other dangerous object or chemical, including but not limited to any facsimile firearm, knife, or explosive on District-owned or controlled property or at District-sponsored or supervised functions without the prior authorization of the President/Superintendent or designee.
3. Unlawful possession, use, sale, offer to sell, or furnishing, or being under the influence of, any controlled substance listed in Chapter 2 (commencing with Section 11053) of Division 10 of the California Health and Safety Code, an alcoholic beverage, or an intoxicant of any kind; or unlawful possession of, or offering, arranging, or negotiating the sale of any drug paraphernalia, as defined in California Health and Safety Code, Section 11014.5.
4. Committing or attempting to commit robbery or extortion.
5. Theft, attempted theft of, or willful damage to District property or property in the possession of, or owned by, a member of the college community or knowingly receiving stolen property or private property on District premises.
6. Willful or persistent smoking in any area where smoking has been prohibited by law or by regulation of the District.
7. Committing sexual harassment as defined by law or by District policies and procedures in person or in an online environment and, when the victim or victims are associated with the District, whether or not the location is associated with the District.
8. Engaging in harassing or discriminatory behavior based on national origin, religion, age, gender, gender identity, gender expression, race or ethnicity, color, medical condition, genetic information, ancestry, sexual orientation, marital status, physical or mental disability, pregnancy, or because he or she is perceived to have one or more of the foregoing characteristics, or based on association with a person or group with one or more of these actual or perceived characteristics, or any other status protected by law in person or in an online environment and, when the victim or victims are associated with the District, whether or not the location is associated with the District.
9. Engaging in intimidating conduct or bullying against another student through words or actions, including direct physical contact; verbal assaults, such as teasing or name-calling; social isolation or manipulation; and cyberbullying.

STUDENT SERVICES AND POLICIES

10. Willful misconduct that results in injury or death to a student, client, patient, visitor, guest, or to District personnel or that results in cutting, defacing, or other injury to any real or personal property owned by the District or on campus.
11. Endangering a student, client, patient, visitor, guest, or District employee or contributing to or causing harm to the health, safety, and/or well-being of such others.
12. Disruptive behavior, continual or willful disobedience and/or persistent defiance of the authority, habitual profanity or vulgarity, or abuse of District personnel or where the presence of the student causes a continuing danger to the physical safety of students or others.
13. Cheating, or engaging in other academic dishonesty including copying from another's work; discussion prohibited by the instructor; obtaining exam copies without permission; and using notes, other information, or devices that have been prohibited.
14. Misrepresentation and/or impersonation, including arranging for or allowing another individual to impersonate or otherwise misrepresent himself or herself to be a student generally or to be a particular student either in person or in an online environment, and/or impersonating or otherwise misrepresenting oneself to be another person in person or in an online environment.
15. Plagiarism, in individual or group work or in a student publication, including the act of taking the ideas, words or specific substantive material of another and offering them as one's own without giving credit to the source.
16. Dishonesty; forgery; alteration or misuse of District documents, records, or identification; or knowingly furnishing false information to the District.
17. Unauthorized entry upon, into, or use of District facilities, either in person or in an online environment.
18. Lewd, indecent or obscene conduct on District-owned or controlled property; or at District-sponsored or supervised functions; or directed at and for the purpose of harming another individual or group associated with the District, whether carried out in person or in an online environment, and whether or not the location is associated with the District.
19. Engaging in expression that is obscene, libelous or slanderous, or that so incites students as to create a clear and present danger of the commission of unlawful acts on college premises, or the violation of lawful District administrative procedures, or the substantial disruption of the orderly operation of the District.
20. Persistent serious misconduct where other means of correction have failed to bring about proper conduct.
21. Unauthorized preparation, giving, selling, transfer, distribution, or publication, for any commercial purpose, of any contemporaneous recording of an academic presentation in a classroom or equivalent site of instruction, including but not limited to handwritten or typewritten class notes, except as permitted by any Board policy or administrative procedure.
22. Unauthorized use of audio, video or other listening, recording or transmitting device in any classroom, service area, or District activity without prior consent of the instructor, service area manager, or activity advisor except as necessary for reasonable accommodation.
23. Failure, as a person involved in sexual activity, to ensure that he or she has the affirmative consent of the other or others to engage in the sexual activity. Lack of protest or resistance does not mean consent, nor does silence mean consent.
 - Affirmative consent must be ongoing throughout a sexual activity and can be revoked at any time. The existence of a dating relationship between the persons involved, or the fact of past sexual relations between them, should never by itself be assumed to be an indicator of consent. "Affirmative consent" means affirmative, conscious, and voluntary agreement to engage in sexual activity.
 - a. In the evaluation of complaints in any disciplinary process, it shall not be a valid excuse to alleged lack of affirmative consent that the accused believed that the complainant consented to the sexual activity under either of the following circumstances:
 - i. The accused's belief in affirmative consent arose from the intoxication or recklessness of the accused.
 - ii. The accused did not take reasonable steps, in the circumstances known to the accused at the time, to ascertain whether the complainant affirmatively consented.
 - b. In the evaluation of complaints in the disciplinary process, it shall not be a valid excuse that the accused believed that the complainant affirmatively consented to the sexual activity if the accused knew or reasonably should have known that the complainant was unable to consent to the sexual activity under any of the following circumstances:
 - i. The complainant was asleep or unconscious.
 - ii. The complainant was incapacitated due to the influence of drugs, alcohol, or medication, so that the complainant could not understand the fact, nature, or extent of the sexual activity.
 - iii. The complainant was unable to communicate due to a mental or physical condition.
24. Sexual assault, defined as actual or attempted sexual contact with another person without that person's consent, regardless of the victim's affiliation with the college; and, effective January 1, 2016, regardless of whether such conduct is related to college activity or college attendance; including, but not limited to, any of the following: (1) Intentional touching of another person's intimate parts without that person's consent or other intentional sexual contact with another person without that person's consent. (2) Coercing, forcing, or attempting to coerce or force a person to touch another person's intimate parts without that person's consent. (3) Rape, which includes penetration, no matter how slight, without the person's consent, of either of the following: (A) The vagina or anus of a person by any body part of another person or by an object. (B) The mouth of a person by a sex organ of another person.
25. Sexual exploitation, defined as a person taking sexual advantage of another person for the benefit of anyone other than that person without that person's consent, regardless of the victim's affiliation with the college; and, effective January 1, 2016, regardless of whether such conduct is related to college activity or college attendance; including, but not limited

to, any of the following: (1) Prostituting another person. (2) Recording images, including video or photograph, or audio of another person's sexual activity, intimate body parts, or nakedness without that person's consent. (3) Distributing images, including video or photograph, or audio of another person's sexual activity, intimate body parts, or nakedness, if the individual distributing the images or audio knows or should have known that the person depicted in the images or audio did not consent to the disclosure and objected to the disclosure. (4) Viewing another person's sexual activity, intimate body parts, or nakedness in a place where that person would have a reasonable expectation of privacy, without that person's consent, and for the purpose of arousing or gratifying sexual desire.

26. Misrepresentation of oneself or of an organization to be an agent of the District.
27. Continued disruption on or off District property of the District's educational or student services activities, administrative functions and procedures, public service functions, authorized curricular or co-curricular activities, other functions, or prevention of authorized guests from carrying out the purpose for which they are on District property.
28. Abuse of any person, or any possession of any person, on District-owned or controlled property.
29. Violation of state or local laws, Board policies, or administrative procedures concerning the registration of student organizations, the use of District facilities, or the time, place, and manner of public expression.
30. Abusive behavior directed toward coercion of, or hazing of, or bullying of a member of the college community, in person or in an online environment and, when the victim or victims are associated with the District, whether or not the location is associated with the District.
31. Violation of Board policies or administrative procedures governing the use of student user accounts, Computers, and telecommunication resources, including but not limited to the unauthorized entry, opening, or viewing of a file; the unauthorized use of another individual's identification and password; arranging for, allowing, and/or impersonation of one person by another; sending obscene or abusive messages or files; and/or use of computing facilities to interfere with the work of another student or employee of the District.
32. Engaging in physical or verbal disruption, intimidation, or harassment of such severity or pervasiveness as to have the purpose or effect of unreasonably interfering with a student's academic performance, or District employee's work performance, or of creating an intimidating, hostile or offensive educational or work environment, in person or in an online environment and, when the victim or victims are associated with the District, whether or not the location is associated with the District.
33. Violation of a duly issued restraining order, stalking, and/or a pattern of conduct with intent to follow, alarm, or harass another person, and which causes the person to reasonably fear for his or her safety, and where the pattern of conduct persisted after the person has demanded that the pattern of conduct cease.
34. Failure to identify oneself when requested to do so by District officials acting in the performance of their duties.
35. Any other cause not listed above which is identified as "Good Cause" by the Education Code or that disrupts the college, its mission, or campus life.

ACADEMIC HONESTY/DISHONESTY POLICY

Your instructors are eager to help you succeed in your studies at Cerritos College. But success means more than just receiving a passing grade in a course. Success means that you have mastered the course content so that you may use that knowledge in the future, either to be successful on a job, or to continue on with your education in advanced classes.

Your success depends on a combination of the skill and knowledge of your instructors, and your own hard work. You will reach your future goals only if you gain new knowledge from every course you take. That knowledge becomes yours and can be used by you, only if it is gained through your own personal efforts. Receiving a grade in a course, without acquiring the knowledge that goes with it, diminishes your chances for future success.

While in college, you are also shaping the principles which will guide you throughout the rest of your life. Ethical behavior and integrity are a vital part of those principles. A reputation for honesty says more about you, and is more highly prized, than simply your academic skills.

For this reason, academic honesty is taken very seriously by the Cerritos College faculty. The following guidelines have been prepared so that you will understand what is expected of you in maintaining academic honesty.

Academic Dishonesty is normally to be dealt with as an academic action by the instructor, reflected in the student's grade in the particular course, rather than through college disciplinary procedures. No specific departmental, divisional or institutional procedures are established for academic dishonesty other than the normal process for review and appeal of an instructor's grading procedures.

Academic Dishonesty is defined as the act of obtaining or attempting to obtain credit for work by the use of any dishonest, deceptive, or fraudulent means. Examples of academic dishonesty would include, but not be limited to the following:

- Copying, either in part or in whole, from another's test or examination;
- Discussion of answers or ideas relating to the answers, on examination or test when such discussion is prohibited by the instructor;
- Obtaining copies of an exam without the permission of the instructor;
- Using notes, "Cheat sheets," or otherwise utilizing information or devices not considered appropriate under the prescribed test conditions;
- Altering a grade or interfering with the grading procedures in any course;
- Allowing someone other than the officially enrolled student to represent the same;
- Plagiarism, which is defined as the act of taking the ideas, words or specific substantive material of another and offering them as one's own without giving credit to the source.

Options may be exercised by the faculty member to the extent that the faculty member considers the cheating or plagiarism to manifest the student's lack of scholarship or to reflect on the student's lack of academic performance in the course. One or more of the following actions are available to the faculty member who suspects a student has been cheating or plagiarizing:

1. Review-no action.
2. An oral reprimand with emphasis on counseling toward prevention of further occurrences.
3. A requirement that work be repeated.
4. A reduction of the grade earned on the specific work in question, including the possibility of no credit for the work.

STUDENT SERVICES AND POLICIES

5. A reduction of the course grade as a result of item 4 above, including the possibility of a failing grade for the course.
6. Referral to the Office of Student Conduct and Grievance for further administrative action, such as suspension or expulsion.

STUDENT DISCIPLINE PROCEDURES

Student Conduct Programs should contribute to the teaching of appropriate individual and group behavior as well as to protecting the campus community from disruption and harm. The Programs should be conducted in ways that will serve to foster the ethical development and personal integrity of students and the promotion of an environment that is in accord with the overall educational goals of the institution. This procedure will be used in a fair and equitable manner, and not for purposes of retaliation. It is not intended to substitute for criminal or civil proceedings that may be initiated by other agencies.

These Administrative Procedures are specifically not intended to infringe in any way on the rights of students to engage in free expression as protected by the state and federal constitutions, and by Education Code Section 76120, and will not be used to punish expression that is protected.

The Office of Student Conduct and Grievances is responsible for the student conduct and sanctioning procedures of the college. Inquiries should be directed to the Office of Student Conduct and Grievances.

STUDENT CONDUCT PROCEDURES AND SANCTIONS

Definitions

District – The Cerritos Community College District.

Day – A day is defined as any day Monday through Friday that all normal College business is conducted, both in the classroom and in the administrative offices. All weekend days and College holidays are excluded.

Student – Any person currently enrolled as a student of the District.

Instructor – Any academic employee of the District in whose class a student subject to discipline is or was enrolled, or counselor who is providing or has provided services to the student, or other academic employee who has responsibility for the student's educational program.

Written or verbal reprimand – An admonition to the student to cease and desist from conduct determined to violate the Standards of Student Conduct. Written reprimands may become part of a student's permanent record at the college. A record of the fact that a verbal reprimand has been given may become part of a student's record at the college for a period of up to one year.

Disciplinary Probation – A period on probation that may include, but is not limited to, exclusion of the individual from designated co-curricular activities of the college for a set period of time.

Removal from class – Exclusion of the student by an instructor for the day of the removal and the next class meeting.

Withdrawal of Consent to Remain on Campus – Withdrawal of consent by the President/Superintendent or designee for any person to remain on campus in accordance with California Penal Code Section 626.4 where the President/Superintendent or designee has reasonable cause to believe that such person has willfully disrupted the orderly operation of the campus.

Short-term Suspension – Exclusion of the student by the President/Superintendent or designee for good cause from one or more classes for a period of up to ten consecutive days of instruction.

Long-term Suspension – Exclusion of the student by the President/Superintendent or designee for good cause from one or more classes for the

remainder of the school term, or from all classes and activities of the college for one or more terms.

Expulsion – Exclusion of the student by the Board of Trustees from the District for one or more terms.

Short-term Suspensions, Long-term Suspensions, and Expulsions

Before any disciplinary action to suspend, or expel is taken against a student, the following procedures will apply:

Notice – The President/Superintendent or designee will provide the student with written notice of the conduct warranting the discipline. The written notice will include the following:

- the specific section of the Standards of Student Conduct that the student is accused of violating.
- a short statement of the facts supporting the accusation.
- the right of the student to meet with the Dean of Student Services or designee to discuss the accusation, or to respond in writing.
- the nature of the discipline that is being considered.

Time limits – The notice must be provided to the student within 20 days of the date on which the administration of the college became aware of the conduct; in the case of continuous, repeated, or ongoing conduct of which the administration of the college has become aware, the notice must be provided within 20 days of the date on which the administration became aware that the conduct occurred which led to the decision to take disciplinary action.

Hearing Officer Meeting – The student is to have a hearing with the Dean of Student Services or designee serving as the district hearing officer. The hearing must occur no sooner than five days after the notice is provided. At the meeting, the student must again be told the facts leading to the accusation, and must be given an opportunity to respond verbally or in writing to the accusation.

Short-term Suspension – Within five days after the meeting described above, the President/Superintendent or designee shall, pursuant to a recommendation from the Dean of Student Services or designee, decide whether to impose a short-term suspension, whether to impose some lesser disciplinary action, or whether to end the matter. Written notice of the President/Superintendent's or designee's decision shall be provided to the student. The notice will include the length of time of the suspension, or the nature of the lesser disciplinary action. The President/Superintendent or designee decision on a short-term suspension shall be final.

Long-term Suspension – Within five days after the meeting described above, the President/Superintendent or designee shall, pursuant to a recommendation from the Dean of Student Services or designee, decide whether to impose a long-term suspension. Written notice of the President/Superintendent or designee decision shall be provided to the student. The notice will include the right of the student to request a formal hearing before the hearing panel before a long-term suspension is imposed, and a copy of this policy describing the procedures for a hearing. The request must be made in writing to the Vice President of Student Services or designee.

Expulsion – Within 10 days after the meeting described above, the President/Superintendent or designee shall, pursuant to a recommendation from the Dean of Student Services or designee, decide whether to recommend expulsion to the Board of Trustees. Written notice of the decision shall be provided to the student. The notice will include the right

Smoking, including the use of electronic cigarettes or other emission-producing products or devices, is prohibited within 20 feet of any exit, entrance, operable window, or ventilation intake of any campus building or structure; in any enclosed area on campus, including lobbies, lounges, courtyards, waiting areas, stairwells, and restrooms that are a part of any building or structure; and in all District vehicles, including gasoline or electric carts.

STUDENT SERVICES AND POLICIES

of the student to request a formal hearing before the hearing panel before expulsion is imposed, and a copy of this policy describing the procedures for a hearing. The request must be made in writing to the Vice President of Student Services or designee.

A decision of the Board of Trustees to impose expulsion shall be reached no later than the next regularly scheduled regular meeting of the Board after receipt of the recommended decision.

Disciplinary Decisions, Sanctions, and Conditions

Written or Verbal Reprimand – May be initiated by any faculty or College manager and sent in writing to the Office of Student Conduct and Grievances. The Disciplinary Officer (Dean of Student Services or designee) shall determine if there exists good and sufficient reason to initiate disciplinary action and the student should be notified of such actions.

Disciplinary Probation – Initiated by the Dean of Student Services or designee. The nature of the misconduct, dates, times, places, and the length of probation shall be placed in writing. Written copies shall be sent to the student and copies filed with the Office of Student Conduct and Grievances.

Removal from Class (Education Code Section 76032) – Any instructor may order a student removed from his/her class for the day of the removal and the next class meeting. The instructor shall immediately report the removal to the Faculty Coordinator for Student Conduct and Grievance and complete a Student Conduct Incident Form. The Faculty Coordinator or designee shall arrange for a conference between the student and the instructor regarding the removal. If the instructor or the student requests, the Faculty Coordinator or designee shall attend the conference. The student shall not be returned to the class during the period of the removal without the concurrence of the instructor. Nothing herein will prevent the Faculty Coordinator, or designee from recommending further disciplinary procedures in accordance with these procedures based on the facts which led to the removal.

Immediate Interim Suspension (Education Code Section 66017) – The President/Superintendent or designee may order immediate suspension of a student where he or she concludes that immediate suspension is required to protect lives or property and to ensure the maintenance of order. In cases where an interim suspension has been ordered, the time limits contained in these procedures shall not apply, and all hearing rights, including the right to a formal hearing where a long-term suspension or expulsion is recommended, will be afforded to the student within ten days.

Withdrawal of Consent to Remain on Campus – The President/Superintendent or designee may notify any person for whom there is a reasonable belief that the person has willfully disrupted the orderly operation of the campus that consent to remain on campus has been withdrawn. If the person is on campus at the time, he/she must promptly leave or be escorted off campus. If consent is withdrawn by the Dean of Student Services or designee, a written report must be promptly made to the President/Superintendent or designee.

The person from whom consent has been withdrawn may submit a written request for a hearing on the withdrawal within the period of the withdrawal. The request shall be granted not later than seven days from the date of receipt of the request. The hearing will be conducted in accordance with the provisions of this procedure relating to interim suspensions.

In no case shall consent be withdrawn for longer than 14 days from the date upon which consent was initially withdrawn.

All applicable conditions of a withdrawal of consent to remain on campus, suspension, or expulsion in effect when a break occurs in the conducting of College business (both in the classroom and in the administrative offices) remain in effect during the break unless specifically excepted in writing by the President/Superintendent or designee.

A withdrawal of consent to remain on campus, suspension, or expulsion prohibits both physical presence on the campus and at a facility or activity operated by the College and any type of online or distance education presence or participation in classes, activities, and/or operations of the College.

Any person as to whom consent to remain on campus has been withdrawn who knowingly reenters the campus during the period in which consent has been withdrawn, except to come for a meeting or hearing, is subject to arrest (Penal Code Section 626.4).

Clearance to Return – Prior clearance to return to the college (in-person and/or online) may be required. Clearance requirements may include completion of educational or other courses or processes as specified in the sanction decision. This requirement may include confirmation that the individual is ready for the college classroom and/or that the individual's continued presence on campus is not a threat to himself/herself, others, and/or the property of the District or others.

Hearing Panel

The hearing panel for any disciplinary action subject to hearing by a panel shall be composed of one administrator, two faculty members, and two students.

Unless he or she determines to keep the prior year's appointees in place, the president of the Faculty Senate, and the President of ASCC shall each, at the beginning of the academic year, establish a list of at least five persons who will serve on student disciplinary hearing panels. The President/Superintendent or designee shall appoint the hearing panel from the names on these lists plus the Dean of Student Services or designee. However, no administrator, faculty member, or student who has any personal involvement in the matter to be decided, who is a necessary witness, or who could not otherwise act in a neutral manner shall serve on a hearing panel.

The hearing panel shall be responsible to the President/Superintendent for reviewing and making a recommendation to the President/Superintendent or designee.

Membership of the hearing panel shall include the following:

1. Two members of the instructional staff appointed by the Faculty Senate.
2. Two ASCC Student Court Justices, or two other students who meet the minimum eligibility requirements to hold office in the ASCC if such justices are party to the matter at hand or are otherwise unavailable to serve, appointed by the ASCC Court Chief Justice or by the Associated Students President, if the Court Chief Justice is a party to the matter.
3. The Disciplinary Officer/Dean of Student Services or designee shall serve as the Chairperson of the Hearing Panel, but will not vote except to break a tie.

STUDENT SERVICES AND POLICIES

Procedures for a Hearing, Disposition, and Imposition of Sanctions

1. Written notice of a hearing shall be mailed or delivered to the student. A hearing must be held within ten days of the suspension if the suspension is immediate.
2. Notice shall include date and place of hearing, a statement of all charges, a copy of applicable policies and procedures, the opportunity of the student to appear in person, and the opportunity to present oral and documentary evidence.
3. Hearings shall be conducted in the manner consistent with the orderly conduct of the affairs of the College, and which seems to the hearing panel to be most conducive to the determination of the truth.
4. The members of the hearing panel shall be provided with a copy of the accusation against the student and any written response provided by the student before the hearing begins.
5. The facts supporting the accusation shall be presented by a college representative who shall be the Dean of Student Services or designee.
6. The college representative and the student may call witnesses and introduce oral and written testimony relevant to the issues of the matter.
7. Formal rules of evidence shall not apply. Any relevant evidence shall be admitted.
8. Unless the hearing panel determines to proceed otherwise, the college representative and the student shall each be permitted to make an opening statement. Thereafter, the college representative shall make the first presentation, followed by the student. The college representative may present rebuttal evidence after the student completes his/her evidence. The burden shall be on the college representative to prove by the preponderance of the evidence that the facts alleged are true.
9. The student may represent himself/herself, and may also have the right to be represented by a person of his/her choice, except that the student shall not be represented by an attorney unless, in the judgment of the hearing panel, complex legal issues are involved. If the student wishes to be represented by an attorney, a request must be presented not less than five days prior to the date of the hearing. If the student is permitted to be represented by an attorney, the college representative may request that legal counsel to the college participate in his/her place. The hearing panel may also request legal assistance; any legal advisor provided to the panel may sit with it in an advisory capacity to provide legal counsel but shall not be a member of the panel nor vote with it.
10. Hearings shall be closed and confidential unless the student requests that it be open to the public. If more than one student's case is under consideration, any and all such other students must also request that the hearing be open to the public in order to make it open to the public. Any such request must be made no less than five days prior to the date of the hearing. Requests contrary to state or federal law or to the safety of the college or participants shall not be approved, subject to appeal to the President/Superintendent or designee.
11. In a closed hearing, witnesses shall not be present at the hearing when not testifying, unless all parties and the panel agree to the contrary.
12. All testimony shall be taken under oath; the oath shall be administered by the hearing panel chair. Written statements of witnesses under penalty of perjury shall not be used unless the witness is unavailable to testify. A witness who refuses to be tape recorded shall not be considered unavailable for the purposes of this section.
13. The hearing shall be recorded by the District either by tape recording or stenographic recording. The official recording shall be the only recording made. No witness who refuses to be recorded may be permitted to give testimony. In the event the recording is by tape recording, the hearing panel chair shall, at the beginning of the hearing, ask each person present to identify themselves by name, and thereafter shall ask witnesses to identify themselves by name. The recording shall remain in the custody of the District at all times, unless released to a professional transcribing service. The student may request a copy of the recording. Transcripts may be redacted to comply with law, policies, and to protect the privacy and/or safety of individuals.
14. Within five days following the close of the hearing, the hearing panel shall prepare and send to the President/Superintendent or designee a written decision. The decision shall include specific factual findings regarding the accusation, and shall include specific conclusions regarding whether any specific section of the Standards of Student Conduct were violated. The decision shall also include a specific recommendation regarding the sanction to be imposed, if any. The decision shall be based only on the record of the hearing, and not on matter outside of that record. The record consists of the original accusation, the written response, if any, of the student, and the oral and written evidence produced at the hearing.

President/Superintendent's Decision:

Long-term suspension – Within five days following receipt of the hearing panel's recommended decision, the President/Superintendent or designee shall render a final written decision. The President/Superintendent or designee may accept, modify, or reject the findings, decisions and recommendations of the hearing panel. If the President/Superintendent or designee modifies, or rejects the hearing panel's decision, the President/Superintendent or designee shall review the record of the hearing, and shall prepare a new written decision which contains specific factual findings and conclusions. The decision of the President/Superintendent or designee shall be final.

Expulsion – Within ten days following receipt of the hearing panel's recommended decision, the President/Superintendent or designee shall render a written recommended decision to the Board of Trustees. The President/Superintendent or designee may accept, modify, or reject the findings, decisions and recommendations of the hearing panel. If the President/Superintendent or designee modifies, or rejects the hearing panel's decision, he/she shall review the record of the hearing, and shall prepare a new written decision which contains specific factual findings and conclusions. The President/Superintendent's or designee's decision for expulsion shall be forwarded to the Board of Trustees.

Board of Trustees Decision:

Expulsion – A decision of the Board of Trustees to impose expulsion shall be reached no later than the next regularly scheduled regular meeting of the Board after receipt of the recommended decision.

STUDENT SERVICES AND POLICIES

The Board shall consider an expulsion recommendation in closed session, unless the student has requested that the matter be considered in a public meeting in accordance with these procedures. (Education Code Section 72122)

The student shall be notified in writing, by registered or certified mail to the address last on file with the District, or by personal service, at least three days prior to the meeting, of the date, time, and place of the Board's meeting.

The student may, within forty-eight hours after receipt of the notice, request that the hearing be held as a public meeting.

Even if a student has requested that the Board consider an expulsion recommendation in a public meeting, the Board will hold any discussion that might be in conflict with the right to privacy of any student other than the student requesting the public meeting in closed session.

The Board may accept, modify, or reject the findings, decisions and recommendations of the President/Superintendent and/or the hearing panel. If the Board modifies or rejects the decision, the Board shall review the record of the hearing, and shall prepare a new written decision which contains specific factual findings and conclusions. The decision of the Board shall be final.

The final action of the Board on the expulsion shall be taken at a public meeting, and the result of the action shall be a public record of the District.

Time Limits – Any times specified in these procedures may be shortened or lengthened if there is mutual concurrence by all parties.

These procedures may change from time to time and may be superseded by current state and federal laws and regulations. Otherwise, the College Catalog, which is updated annually, contains the most recent information regarding student discipline procedures.

Also see BP 5500 titled Standards of Student Conduct.

STUDENT CONDUCT AND GRIEVANCE

Information regarding student rights and responsibilities is available from the Dean of Student Services. The dean is available to meet with you to explain the "System" and your rights with regard to student grievances, student conduct and academic-related student grievances. This office also serves as a source of information and/or referral for all student problems and concerns. The office is located in the Office of Student Affairs. Inquiries should be directed to the Dean of Student Services in the Office of Student Affairs or by calling (562) 860-2451, ext. 2445.

TITLE IX POLICY

No person in the United States shall, on the basis of sex, be excluded from participation in, be denied the benefits of, or be subject to discrimination under any educational program or activity receiving Federal financial assistance (Title IX of the Educational Amendments of 1972 to the 1964 Civil Rights Act).

It is the policy of the State of California to afford all persons, regardless of their sex or gender identity, equal rights and opportunities in the educational institutions of the state (Educational Code sections 200 – 264).

In compliance with Title IX and Board Policy 3410, the District's educational programs and activities are offered to the community without regard to sex or gender identity. Title IX prohibits discrimination based on sex in educational programs and activities that receive Federal financial assistance. Examples of programs and activities that are subject to Title IX include admissions, recruitment, financial aid, academic programs, athletics and employment. Title IX also protects students from sexual harassment, including sexual violence, such as rape, other forms of sexual assault, sexual battery and sexual coercion.

Title IX Coordinator

Cerritos College's Title IX Coordinator monitors and oversees the college's compliance with Title IX and the prevention of sex harassment and discrimination, including the coordination of education and training activities and the response to Title IX complaints. Students, faculty, administrators, staff, visitors, or others who participate in the District's educational programs and activities with questions, concerns, or complaints about sex discrimination, sex harassment or sexual misconduct are encouraged to contact the Title IX Coordinator at:

Dr. Valyncia C. Raphael

Director of Diversity, Compliance, and Title IX Coordinator
Office of Human Resources

Cerritos College, 11110 Alondra Blvd., Norwalk, CA 90650

(562) 860-2451, ext. 2276; (562) 467-5003 Fax

<https://www.cerritos.edu/title-ix/>



STUDENT SERVICES AND POLICIES

EQUAL OPPORTUNITY POLICY

Cerritos College does not discriminate in educational and employment on the basis of ancestry, age, color, creed, disability (physical and mental, includes HIV and AIDS), genetic information, gender identity, gender expression, marital status, medical condition (genetic characteristics, cancer or a record or history of cancer), military or veteran status, national origin, race, religion (includes religious dress and grooming), sex/gender (includes pregnancy, childbirth, breastfeeding and/or related medical conditions), sexual orientation, or on the basis of perception of having one or more of the foregoing characteristics, or based on association with a person or group with one or more of these actual or perceived characteristics, or any other status protected by law in person or in an online environment and, when the victim or victims are associated with the District, whether or not the location is associated with the District.

The District is strongly committed to achieving staff diversity and the principles of equal opportunity education and employment. The District encourages a diverse pool of applicants for employment and does not discriminate in any of its policies, procedures, or practices. The District encourages applications from all segments of qualified people and Board Policies 3410 and 3420 prohibit discrimination and promote equal opportunity.

Questions concerning the application of the policy may be addressed to Dr. Valyncia C. Raphael in the Office of Human Resources by calling (562) 860-2451, ext. 2276.

SECTION 504/508/AMERICANS WITH DISABILITIES ACT

Under Section 504/508/ADA of the Rehabilitation Act of 1973 and Title II of the Americans with Disabilities Act of 1990, Cerritos College will take all necessary steps to ensure that no student with a verified disability is denied the benefits of, excluded from participation in, or otherwise subjected to discrimination because of the absence of auxiliary aids or academic accommodations. The decision to authorize such aids or accommodations is the responsibility of the Disabled Student Programs and Services (DSPS) Dean,

Disability Specialist, or DSPS counselor after a review of documentation verifying the disability and any resulting educational limitations.

It is the responsibility of the student with a verified disability and resulting educational limitations to apply for DSPS assistance in the Liberal Arts/DSPS building by completing the DSPS form entitled “Disabled Student Programs and Services – New Student Application”. The request should be completed with adequate notice provided for an effective response, especially during busy times such as the start of the semester. All authorized accommodations are determined via an interactive process which includes the DSPS specialist, the student, and review of disability documentation. It is the student’s responsibility to request in advance to receive the authorized accommodations each semester. If the instructor denies the classroom-related request(s) the DSPS Dean or designee will intervene with the appropriate academic staff and attempt to resolve the matter. In the event of continued denial of an accommodation request or request for course substitution or waiver, DSPS will provide the student with the Academic Accommodations Policy and related procedures/forms. The DSPS Dean or designee will concurrently inform the student that he/she has the right to file a complaint under the College’s discrimination complaint procedure and/or the Office for Civil Rights, and will provide the student with the information necessary to do so. Inquiries regarding DSPS or the District’s non-discrimination policy relative to students, employees, or applicants with disabilities should contact the Director of Diversity, Compliance, and Title IX Coordinator at extension 2276, in the Office of Human Resources.

SECTION 504/508 COMPLAINT PROCEDURE

The student should first discuss the complaint regarding discrimination due to a disability with the individual(s) involved or with the Director of Diversity, Compliance, and Title IX Coordinator at extension 2276. Alternatively the student may submit a complaint electronically at <http://www.cerritos.edu/dsps-complaint>.

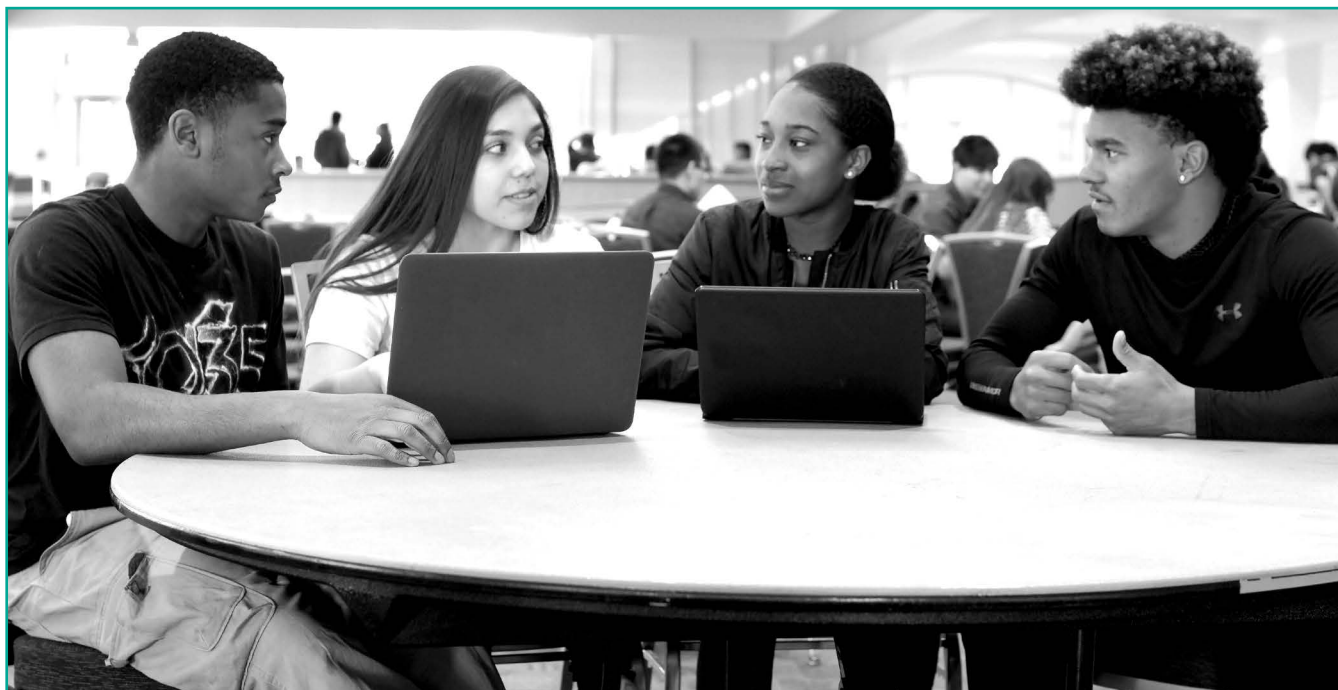

ALCOHOL AND DRUG POLICY

BP 3550 – DRUG AND ALCOHOL FREE ENVIRONMENT AND DRUG AND ALCOHOL ABUSE PREVENTION PROGRAM

The District shall maintain a drug and alcohol free campus/workplace environment for students and employees. The District prohibits the unlawful possession, use, or distribution of illicit drugs and/or alcohol by students and employees.

The unlawful manufacture, distribution, dispensing, possession, or use of a controlled substance is prohibited in all facilities under the control and use of the District.

Any student who violates this policy will be subject to disciplinary action, which may include, but is not limited to, referral to an appropriate rehabilitation program, suspension or expulsion. Any employee who violates this policy will be subject to disciplinary action up to and including termination. The District may refer students and employees who violate this policy to the Campus Police or other appropriate law enforcement agency for appropriate criminal action.

The President/Superintendent shall assure that the District annually distributes the information required by the Drug-Free Schools and Communities Act Amendments of 1989 to all students and employees and that the District complies with other requirements of the Act.

The President/Superintendent shall ensure that a biennial report is prepared to review the effectiveness of the District's policies and programs in maintaining a drug and alcohol free campus and workplace environment.

The District is committed to providing its employees and students with an alcohol and drug-free campus and workplace environment. It emphasizes prevention and intervention through education.

Health Risks That May Be Associated with the Use of Illicit Drugs and the Abuse of Alcohol

- Partner and/or child abuse.
- Unintended injuries or death, including motor vehicle crashes.
- Sexual assault, including rape, sexual battery, and threat of sexual assault; dating violence; domestic violence; stalking; and failure to have affirmative consent.
- Being hit, otherwise assaulted, violently attacked, and/or murdered by another under the influence.
- Sexual activity without protection against HIV, hepatitis (A, B, and C), and other STDs.
- Unsafe interactions with medications, including more than 150 medications that should not be mixed with alcohol.
- Binge and other drinking behaviors leading to ingestion of toxic amounts of alcohol, which can lead to alcohol poisoning, with effects including mental confusion, stupor, coma, inability to be roused, vomiting, seizures, slow or irregular breathing, hypothermia, bluish skin color, and paleness, and, if left untreated, seizures, permanent brain damage, and/or death.
- Premature births and low birth weights; alcohol and illicit drug-related birth defects, including fetal alcohol syndrome (FAS) involving severe physical, mental, and behavioral problems; and in the case of prenatal cocaine exposure, a 1.5 times increased likelihood of needing special education services in school.
- Suicide.
- Long-term health problems including liver disease; heart disease; cancers including those of the mouth, throat, larynx (voice box), breast, rectum, and colon; and pancreatitis.
- Homelessness.

Prevention and Intervention Programs

The District provides education and maintains programs and services designed to aid students, employees and their families in receiving assistance for alcohol and/or drug abuse problems. Included in these educational and assistive programs and services are:

- Notification of the dangers of drug use and dependency in the class schedule;
- Mental health services provided to students through the Student Health Services; and
- An Employee Assistance Program (EAP) for employees and their families.

Alcohol and Drug Prohibitions

The unlawful manufacture, distribution, dispensing, possession, or use of alcohol or any controlled substance is prohibited on District property, during District-sponsored field trips, activities or workshops, and in any facility or vehicle operated by the District.

Violation of Board Policy 3550, Drug and Alcohol Free Environment and Drug and Alcohol Abuse Prevention Program, will be addressed by the District. The District will take appropriate action designed to address each specific violation, which may include, but is not limited to:

- Termination of employment,
- Expulsion,
- Referral to Campus Police or other law enforcement agency for prosecution as permitted by law, or
- Mandatory participation in an alcohol or drug abuse assistance or rehabilitation program.

As a condition of employment, employees of the District will have their fingerprints recorded with the California State Department of Justice and any conviction or violations of the law involving drugs and/or alcohol will be reported to Campus Police and to the Office of Human Resource Services pursuant to the requirements of law. In addition, employees must notify the District within five (5) calendar days of any conviction for violation of a criminal drug statute occurring in the workplace. The District is required to report any violations of criminal drug or alcohol statutes that occur in the workplace to the United States Department of Education on an annual basis.

Information regarding legal sanctions under federal, state, and local laws is available in the following locations:

1. Library
2. Office of Human Resources
3. Office of Student Affairs
4. Student Health Services

Alcohol/Drug Abuse Counseling, Treatment, Rehabilitation Information

Referral information and Social Service Directories for Los Angeles and Orange Counties are available in the following locations:

1. Counseling Center, ext. 2231
2. Student Health Services, ext. 2321

CAMPUS PHONE EXTENSIONS

CERRITOS COLLEGE COMMUNICATION CENTER: (562) 860-2451
HOURS: 8:00 am – 7:00 pm, Monday – Thursday; 8:00 am – 4:30 pm, Friday

QUESTION/PURPOSE	CALL (562) 860-2451	EXT. #
Address change	Admissions and Records Office	2211
Admissions and Records	Admissions and Records Office	2211
Assessment/Placement Testing	Multi-Purpose Building	2599
Bookstore	Bookstore	2450
CalWORKs	CalWORKs Office	2593
Career Services	Career Services Center	2356
Child Care	Child Development Center	2583
Community Education	Community Education	5050
Counseling	Counseling Services	(562) 467-5231
Disabled Student Programs and Services	Disabled Student Programs and Services	2335
Distance Education Courses	Distance Education Program	7891
Emergencies	Campus Police	Use emergency phone or dial 911*
Enrollment	Admissions and Records Office	2211
Extended Opportunities Programs and Services	EOPS	2398
Financial Aid and Scholarships	Financial Aid	2397
International Student Advisement	Office of International Student Services	2133
Job Placement	Career Services Center	2366
Library	Library	2430
Lost and Found	Campus Police	2325
Northwood University	Automotive Partners Building	7852
Parking Information	Campus Police	2325
Personal Counseling	Student Health Services	2321
Police Department	Campus Police	2325
Reentry Program	Career Services Center	2362
Refunds	Admissions and Records Office	2211
Student Body Activities	Office of Student Affairs	2473
Student Conduct and/or Grievance Information	Office of Student Affairs	2483
Student Health Services	Student Health Services Center	2321
Student ID Center	Admissions & Records Office	2120
Transfer Center	Counseling Services/Administration Building	2154
Tutoring	Success Center	7891
Veterans Education	Veterans Resource Center	3716
Withdrawing from College	Admissions and Records Office	2211

DIVISIONS

Business, Humanities & Social Sciences Divison	Business Education Building	2752
Counseling Division	Administration Building	(562) 467-5231
Fine Arts & Communications Division	Fine Arts Building	2600
Health Occupations Division	Health Science Building	2550
Kinesiology Division	Physical Education Building	2859
Liberal Arts Division	Liberal Arts/DSPS Building	2858
Science, Engineering & Mathematics Division	Physical Science & Technology Building	2660
Technology Division	Physical Science & Technology Building	2900

Emergency phones are found in the following locations and are to be used for emergency purposes only. These phones are a direct line to the campus police department; therefore, when using them please be sure to: identify yourself when placing the call — identify the nature and location of the emergency.

Administration Building	Admissions and Records Office Records Room (Vault) only
Burnight Center Building	Lobby/Elevator, Music Wing/Elevator
Business Education Building	North Wing, South Wing
Cafeteria	Student Center
Classroom Building	Hallway
Fine Arts Complex	1st and 2nd Floors, Next to the Elevators
Gym	1st and 2nd Floors, Next to the Elevators
Health Science Building	1st, 2nd, and 3rd Floors, East Elevator, West Elevator
Liberal Arts/DSPS Building	Intercoms, 1st and 2nd Floors Next to Elevators
Library	Elevator East Wing
LRC	Near Center Elevator of Upper/Lower Levels
Math/CIS Building	1st and 2nd Floors, Next to the Elevators
Multi-Purpose Building	1st Floor, East Exterior near Men's Restroom; 2nd Floor, West End
Physical Education Building	1st and 2nd Floors, Next to the Elevators
Physical Science & Technology Building	1st Floor, West End/East End; 2nd Floor, West End/East End
Science Building	1st and 2nd Floors
Skills Lab	West End/East End
Social Science Building	1st, 2nd, and 3rd Floors, Elevator
Weight Training Room	Near Room 3

The emergency phones can be used for any of the following: emergencies, escorts, medical aid, reports of a crime, keys locked in car. From cell phones, reach Campus Police by calling (562) 402-3674 (for 911 emergency calls only).

FINAL EXAM SCHEDULE/ SPRING 2020

LOCATION

Examinations will be conducted in the same room used for the regular class meeting.

WEEKEND CLASSES

Saturday and Sunday classes will hold a two-hour final exam on May 16 and 17 on the regular class day, beginning at the regular class time.

Final examinations for all day classes will be held according to this schedule. On the chart below, find the appropriate square which identifies the starting day and time for your class during the regular semester. From this you can determine the date and two-hour time block for your final exam. Check with your instructor if your class day or start time does not appear on this final exam schedule.

LAST DAY OR EVENING FOR CLASSROOM INSTRUCTION IS FRIDAY, MAY 15.

EXAM TIME	MAY 18 Monday	MAY 19 Tuesday	MAY 20 Wednesday	MAY 21 Thursday	MAY 22 Friday
6 AM TO 8 AM	6:00 MTWTH 6:30 MW	6:30 TTH	6:30 DAILY	6:30 TH	6:30 F
8 AM TO 10 AM	7:00 MW 7:00 MTWTH 7:30 MW 8:00 M 8:00 MW 8:30 MW	7:00 TTH 7:15 TTH 7:30 TTH 8:00 T 8:30 T	7:00 MWF 8:00 W 8:00 WF 8:00 DAILY 8:30 WF	8:00 TH 8:00 TTH 8:00 MTWTH 8:30 TTH 8:30 DAILY	7:30 F 8:00 F 8:00 MWF 8:30 MF 8:30 F
10 AM TO 12 PM	9:00 M 9:00 MTWTH 9:30 M 10:00 M 10:00 MW 10:30 MWF 10:30 MTWTH	9:00 T 9:00 TTH 9:30 T 9:30 TTH 9:45 TTH 10:00 T	9:00 W 9:00 MW 9:00 MWF 9:30 W 9:30 MW 10:00 WF	9:00 TH 9:00 TWTH 9:30 TH 10:00 TTH 10:30 TTH	9:00 F 9:30 F 10:00 F
12 PM TO 2 PM	11:00 M 11:00 MW 11:00 MTH 11:30 M 11:30 MW 11:30 MTWTH 12:00 M 12:00 MW 12:30 M	11:00 T 11:00 TTH 12:00 T 12:00 MTWTH 12:30 T 12:30 MTWTH	11:00 W 11:00 WF 11:00 MWF 12:00 W 12:00 MWF 12:30 W 12:30 MW 12:30 WF	11:00 TH 11:30 TH 12:00 TH 12:00 TTH 12:30 TH 12:30 MTH 12:30 TTH 12:30 WTH	11:00 F 12:00 F 12:30 F 12:00 DAILY 12:30 DAILY
2 PM TO 4 PM	1:00 M 2:00 M 2:00 MW 2:00 MWF 2:00 DAILY 2:30 M 2:30 MW	1:00 T 1:00 TTH 1:30 T 1:30 TTH 2:00 T 2:30 T 2:30 TTH	1:00 W 1:00 MW 1:00 MWF 1:30 W 1:30 MW 2:00 W	1:00 TH 1:00 DAILY 1:00 MTWTH 1:30 MTWTH 2:00 TH 2:00 TTH 2:00 MTWTH 2:30 TH	1:00 F 1:00 MF 1:00 WF 1:30 F 2:00 F 2:00 MWF 2:30 DAILY
4 PM TO 6 PM	3:00 M 3:00 MW 3:00 MTWTH 3:15 MW 3:30 M 3:30 MW 3:30 MTWTH 4:00 M	3:00 T 3:00 TTH 3:30 T 3:30 TTH 4:00 T 4:00 DAILY	3:00 W 3:00 MWF 3:30 W 4:00 W 4:00 MW 4:00 MTWTH 4:30 MW	3:00 TH 3:30 TH 4:00 TH 4:00 TTH 4:30 TTH	3:00 F 3:00 DAILY 4:00 F 4:30 WF 4:30 DAILY
EXTENDED DAY FINALS					
6 PM TO 8 PM	5:00 M 5:00 MW 5:30 M 6:00 M 6:00 MW 6:30 M 6:30 MW	5:00 T 5:30 T 5:30 TTH 6:00 T 6:00 TTH 6:30 T 6:30 TTH	5:00 W 5:30 W 5:30 MW 6:00 W 6:30 W	5:00 TH 5:00 TTH 5:30 TH 5:30 MTWTH 6:00 TH	5:00 F 5:00 MF 5:30 F 6:00 F 6:30 F
8 PM TO 10 PM	7:00 M 7:00 MW 7:00 MTWTH 7:30 M 7:30 MW 8:00 M 8:00 MW	7:00 T 7:00 TTH 7:30 TTH 7:30 TTH 8:00 T 8:00 TTH 8:30 TTH	7:00 W 7:00 WTH 7:30 W	7:00 TH 7:00 THF 7:30 TH	7:00 F 7:30 F

SPECIAL SITUATIONS:

- These exam times are subject to change and will be announced by instructors.
- Classes scheduled for a double period on one day and a single period another day (e.g. 8 - 10 T Th and 9 Th) will have the final examination scheduled for that hour (8) on which the class meets both days (T Th) (for example, exam will be from 8 - 10 T).
- Classes scheduled in a block on a single day (e.g. 9 - 12 T or 12 - 4 F) will take the final examination scheduled for the first hour on which the class meets (for example, exam time will be from 10 - 12 T for the 9 - 12 T class and 12 - 2 F for the 12 - 4 F class).
- Students whom because of personal illness are unable to take examinations as scheduled must make individual arrangements with the instructor involved.

CAMPUS MAP

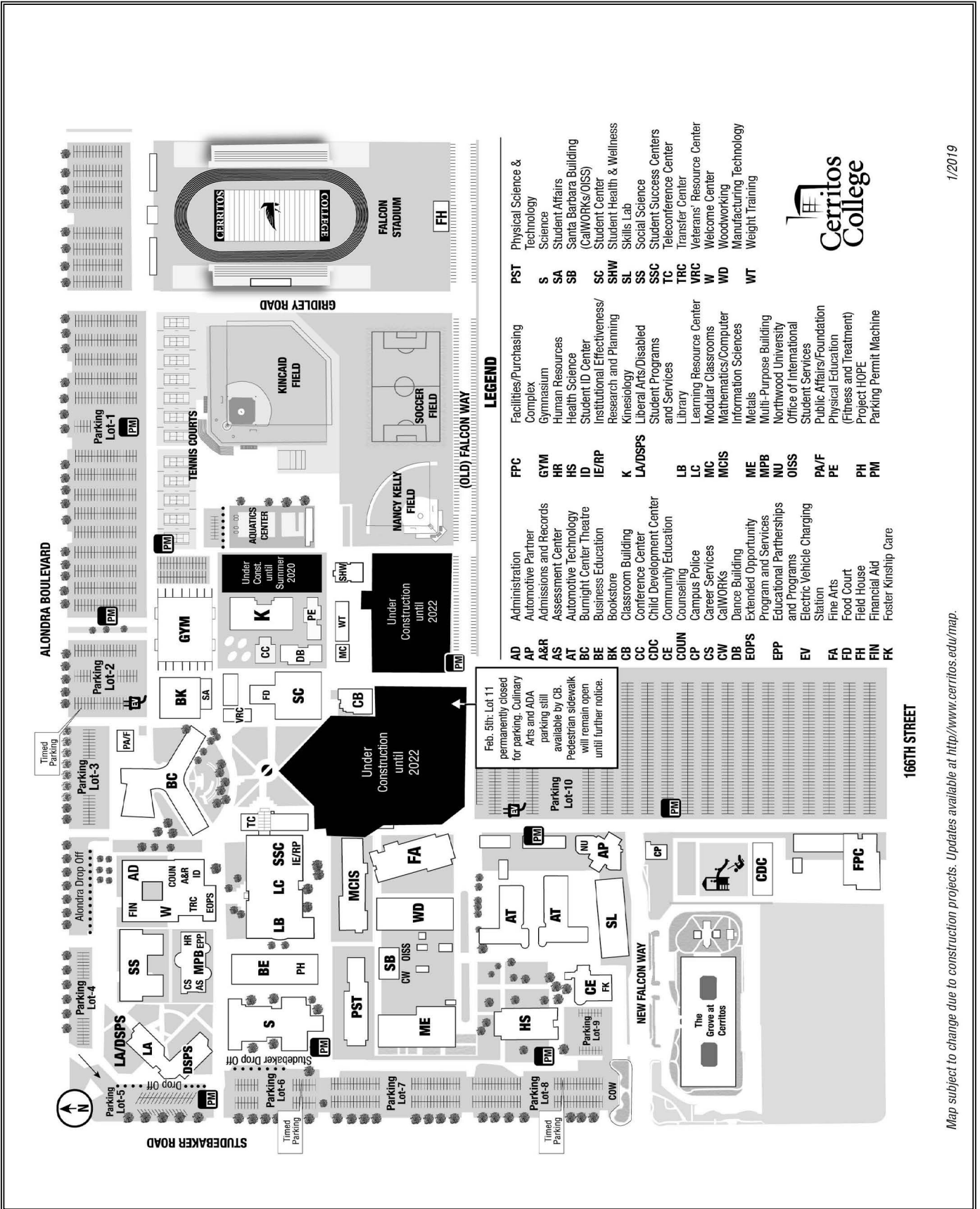

LEGEND

Code	Building Name	Code	Building Name
AD	Administration	AP	Physical Science & Technology
AP	Automotive Partner	S	Science
A&R	Admissions and Records	SA	Student Affairs
AS	Assessment Center	SB	Santa Barbara Building (CAWORKS/OISS)
AT	Automotive Technology	SC	Student Center
BC	Burnight Center Theatre	SHW	Student Health & Wellness
BE	Business Education	SL	Skills Lab
BK	Bookstore	SS	Social Science
CB	Classroom Building	SSC	Student Success Centers
CDC	Child Development Center	TC	Teleconference Center
CE	Community Education	TRC	Transfer Center
COUIN	Counseling	VRC	Veterans' Resource Center
CP	Campus Police	W	Welcome Center
CS	Career Services	WD	Woodworking
CW	CAWORKS	WT	Weight Training
DB	Dance Building		
EDPS	Extended Opportunity Program and Services		
EPP	Educational Partnerships and Programs		
EV	Electric Vehicle Charging Station		
FA	Fine Arts		
FD	Food Court		
FH	Field House		
FIN	Financial Aid		
FK	Foster Kinship Care		
LA/DSPS	Liberal Arts/Disabled Student Programs	FPC	Facilities/Purchasing Complex
LC	Learning Resource Center	GYM	Gymnasium
LC	Learning Resource Center	HR	Human Resources
MC	Modular Classrooms	HS	Health Science
MCIS	Mathematics/Computer Information Sciences	ID	Student ID Center
ME	Metals	IE/RP	Institutional Effectiveness/Research and Planning
MPB	Multi-Purpose Building	K	Kinesiology
NU	Northwood University	LA/DSPS	Liberal Arts/Disabled Student Programs
OISS	Office of International Student Services	LB	Library
PA/F	Public Affairs/Foundation	LC	Learning Resource Center
PE	Physical Education (Fitness and Treatment)	MC	Modular Classrooms
PH	Project HOPE	MCIS	Mathematics/Computer Information Sciences
PM	Parking Permit Machine	ME	Metals
		MPB	Multi-Purpose Building
		NU	Northwood University
		OISS	Office of International Student Services
		PA/F	Public Affairs/Foundation
		PE	Physical Education (Fitness and Treatment)
		PH	Project HOPE
		PM	Parking Permit Machine



1/2019

Map subject to change due to construction projects. Updates available at <http://www.cerritos.edu/map>.

EASY REFERENCE COURSE LISTINGS

COURSE	PAGE	COURSE	PAGE
A			
Access Learning	32	Interdisciplinary Studies	67
Accounting	32	J	
Administration of Justice	33	Japanese	67
Adult Education	99	Journalism	67
American Sign Language	33	K	
Anatomy and Physiology	34	Kinesiology	67
Anthropology	34	L	
Architecture	35	Law	68
Art and Design	35	Library Resources	69
Astronomy	37	M	
Athletics	38	Machine Tool Technology	69
Autobody/Collision and Repair	38	Mathematics	70
Automotive Technology	39	Medical Assisting	73
B			
Biology	40	Microbiology	74
Botany	41	Music	74
Business Administration	41	N	
Business Communications	44	Nursing	76
C			
Chemistry	45	P	
Child Development	46	Paralegal (see Law)	68
Chinese	47	Pharmacy Technology	78
Communication Studies (Formerly Speech)	47	Philosophy	78
Computer and Information Sciences	48	Photography	79
Cosmetology	51	Physical Education	79
Counseling	52	Physical Science	83
Culinary Arts	52	Physical Therapist Assistant	83
D			
Dance	53	Physics	84
Dental Assisting	54	Plastics/Composites	84
Dental Hygiene	55	Political Science	85
Drafting (see Engineering Design Technology)	58	Psychology	85
E			
Earth Science	55	R	
Economics	56	Radio-Television	87
Education	57	Reading and Study Skills	87
Educational Technology	57	Real Estate	87
Engineering	57	S	
Engineering Design Technology	58	Sociology	88
Engineering Technology	58	Spanish	88
English	58	Speech (see Communication Studies)	47
English as a Second Language	61	Speech-Language Pathology	89
F			
Film	62	T	
Finance	63	Theatre Arts	89
French	63	W	
G			
Geography	63	Welding	90
Geology	64	Women's and Gender Studies	91
German	64	Woodworking	92
H			
Health Education	64	Z	
Health Occupations	65	Zoology	93
History	65		
Humanities	66		

Cerritos College Transfer Center Spring Time Line



January 2020
Update UC application including fall 2019 grades and spring 2020 coursework. Send the CSUs official transcripts showing fall 2019 grades (all fall 2020 applicants). Apply for financial aid by completing the FAFSA form online at www.fafsa.gov (list up to 10 CSU/UC/private universities on the form).

July 2020
UC applicants submit official transcripts from all institutions to UC campus of choice to include spring grades by July 1.



February/March 2020
By submitting the FAFSA or Dream Act Application and the G.P.A. verification form by March 2, you may be eligible to receive a Cal Grant. For more information go to www.cerritos.edu/finaid.
Keep checking email for university updates.

June 2020
UC Statement of Intent to Register due by June 1st. Upon selecting your college, request IGETC certification for Admissions & Records for the Intended UC campus. IGETC certification due by July 15 (4-6 weeks to process).



April 2020
CSU/UC admissions letters sent or check online at campus websites.

May 2020
CSU Statement of Intent to Register due by May 1st.
Attend Transfer Celebration
CSU applicants send another official transcript with spring grades to CSU campuses; once admitted, request GE certification from Admissions & Records for the intended CSU/UC campus.



Cerritos College Transfer Center
Located in the Administration Building (AD), West Quad
Monday through Thursday, 8 a.m. - 7 p.m.; Friday, 8 p.m.-2 p.m. Office hours are subject to change.
(562) 860-2451, ext. 2154 • www.cerritos.edu/transfer



Forensics Team Wins Third Place at National Tournament



The Cerritos College Forensics Team competed at the Pi Kappa Delta National Convention and Tournament in Hempstead, New York in March. The team travelled across the country to compete with students from 71 colleges and universities. Team president Anthony Gomez led the way with a Superior Award in impromptu speaking, and Steve Guerra received an Excellent Award in individual debate. TiNa Vejar, Sabrina, Hendifar, and Adriana LaFuente won three of their six debates, contributing to the team's sweepstakes totals. Debbie Grandin also competed in both speech and debate events.

Between rounds of competition, students were able to explore Manhattan. The team navigated the nation's busiest subway system, took in sights such as the National September 11 Memorial & Museum and Battery Park, visited the American Museum of Natural History, and even ventured to the top of the Empire State Building.

Cerritos College Receives More than \$1 Million in Gifts to Prepare Future Educators

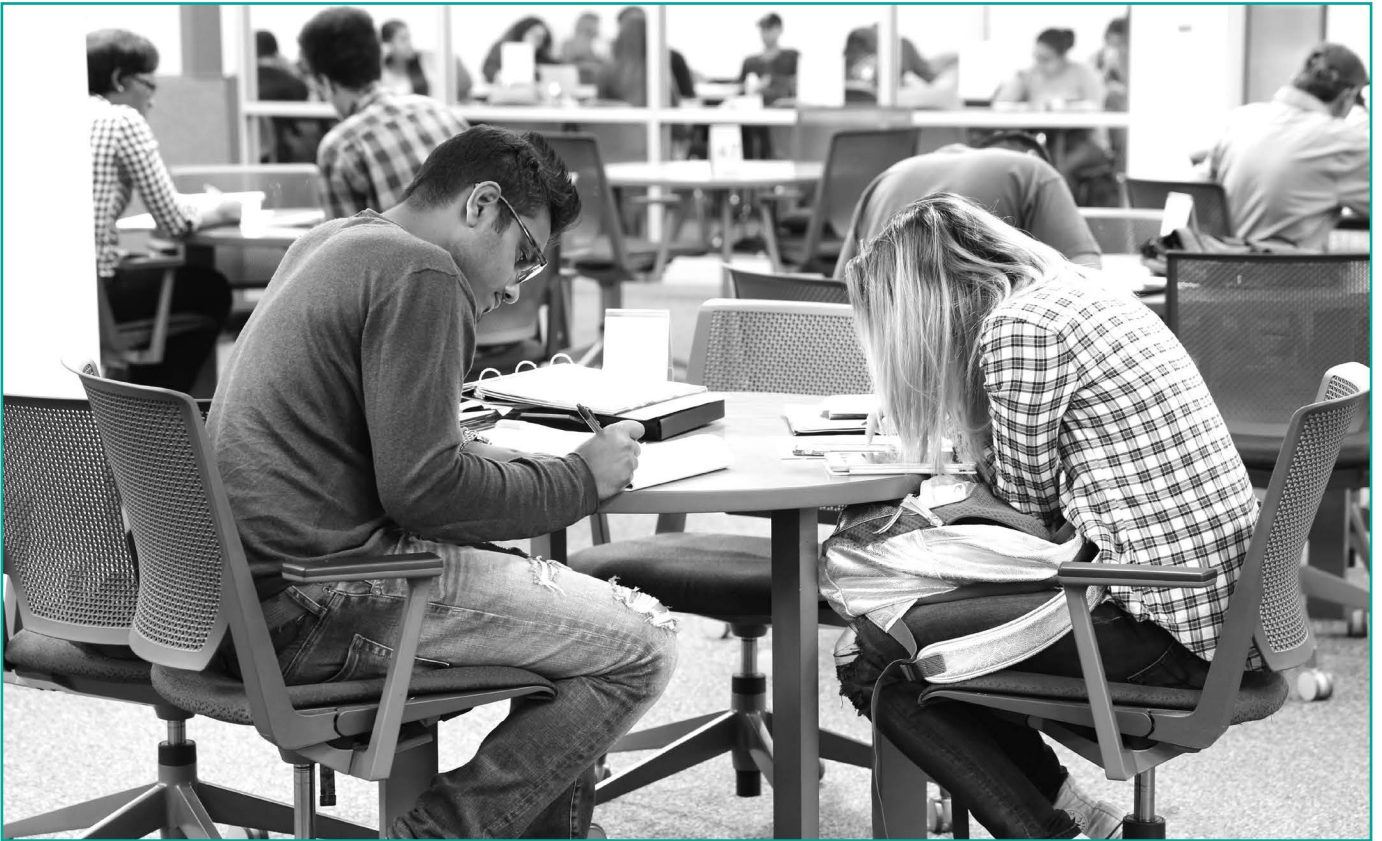

President/Superintendent Dr. Jose Fierro announced the College's Teacher TRAC program received a legacy gift of more than \$1 million to support aspiring teachers. Two educators who arranged to leave their estate to the Cerritos College Foundation made the gift anonymously. The funds will go toward ensuring long-term continuity of the College's award-winning teacher preparation program. Additionally, an unnamed donor pledged a generous cash gift of \$100,000 to the program, adding to a total of more than \$1,100,000 in funds.

For 19 years Cerritos College's award-winning Teacher TRAC program has prepared students to become highly qualified K-12 teachers. The program provides students with a seamless transition to earning a bachelor's degree and teaching credential at California State University, Long Beach. To date Teacher TRAC has trained more than 800 teachers who work across Southern California and nationally.

