

## 2020 FALL SESSIONS

August 17 - December 18, 2020  
18-Week Session

August 17 - November 27, 2020  
1st 15-Week Session

August 17 - October 16, 2020  
1st 9-Week Session

September 8 - December 18, 2020  
15-Week Intrasession

October 19 - December 18, 2020  
2nd 9-Week Session



# FALL 2020

## Class Schedule

Cerritos Community College District  
11110 Alondra Blvd., Norwalk, CA 90650  
562-860-2451 | [www.cerritos.edu](http://www.cerritos.edu)



Keep your momentum  
going with our  
**new programs**  
this fall.



## Cerritos College Online

- Business Administration
- Commercial Music
- Cloud Computing
- Cyber Security
- Network/Systems Administration

## Other New Programs

- Accelerated Crossover Esthetician
- Film, TV, and Electronic Media
- Hospitality Management
- Social Justice: Africana Studies

Enroll now and earn a New Associate of Art for Transfer (AA-T), Associate of Science for Transfer (AS-T) degrees, or an accelerated certificate program.

Register for fall online [www.cerritos.edu/fall/](http://www.cerritos.edu/fall/)

## Associate Degrees for Transfer Available at Cerritos College

- |   |                                    |
|---|------------------------------------|
| ■ Administration of Justice             | ■ Hospitality Management           |
| ■ Anthropology                          | ■ Journalism                       |
| ■ Art History                           | ■ Kinesiology                      |
| ■ Biology                               | ■ Mathematics                      |
| ■ Business Administration               | ■ Music                            |
| ■ Chemistry                             | ■ Philosophy                       |
| ■ Communication Studies                 | ■ Physics                          |
| ■ Computer Science                      | ■ Political Science                |
| ■ Early Childhood Education             | ■ Psychology                       |
| ■ Economics                             | ■ Social Justice: Africana Studies |
| ■ Elementary Teacher Education          | ■ Sociology                        |
| ■ English                               | ■ Spanish                          |
| ■ Film, Television and Electronic Media | ■ Studio Arts                      |
| ■ Geography                             | ■ Theatre Arts                     |
| ■ Geology                               |                                    |
| ■ History                               |                                    |

**Associate Degree for Transfer**  
ADegreeWithAGuarantee.com

<p><b>READY...</b></p> <ul style="list-style-type: none"> <li>■ See a counselor and develop an education plan</li> <li>■ Identify a major</li> <li>■ Attend a transfer workshop</li> <li>■ Visit the transfer center (each term)</li> </ul>	<p><b>SET...</b></p> <ul style="list-style-type: none"> <li>■ Apply to CSUs</li> <li>■ Check email &amp; student portals frequently</li> <li>■ Petition/apply for AA-T/AS-T degree</li> <li>■ Meet CSU deadlines for AA-T/AS-T degree</li> <li>■ Complete the FAFSA <a href="http://fafsa.ed.gov">fafsa.ed.gov</a></li> </ul>	<p><b>GO...</b></p> <ul style="list-style-type: none"> <li>■ Submit intent to enroll</li> <li>■ Request final transcripts to be sent to your CSU</li> </ul>
---	---	---

# iFalcon

## Habits of Mind

[www.cerritos.edu/ifalcon](http://www.cerritos.edu/ifalcon)

**Focus**

Prioritize your tasks

**Advance**

Setting personal, transfer, and degree goals

**Link Up**

with class peers, profs, clubs

**Comprehend**

Connecting personal and academic knowledges

**Organize**

Developing academic independence

**New Ideas**

Growing comfortable with diversity

**Get into the  
Habit!**



# MESSAGE FROM THE PRESIDENT



Welcome to the Fall Semester! I hope you are as excited as I am to start the academic year.

Whether you plan to head into the workforce or transfer to a four-year university, the next phase of your life will begin when you enroll here as a Cerritos College student. We have been recognized nationally for our innovation and commitment to student success, and our dedicated faculty and staff are here to help you navigate college life and meet your goals. We offer a comprehensive range of student support services and resources designed to help you succeed, and there are many ways to become involved in campus life through student clubs and leadership opportunities.

We strive to meet the needs for the intellectual, social, ethical, professional, cultural, and creative facets of students' lives. You can take one class or a full load of 12 units. You can learn in our classrooms and laboratories, or you can take courses online. We want to prepare you for the future so that the skills you learn today will support you tomorrow.

Thank you for considering us. If you are already part of our family, I hope you're enjoying your experience. I look forward to you joining us here at Cerritos, and hope to shake your hand when you earn your diploma.

Sincerely,

Jose L. Fierro, D.V.M., Ph.D.  
President/Superintendent

## OUR MISSION

*Cerritos College provides its diverse student population with high-quality, comprehensive instructional programs and support services through clear, equity-minded pathways to their educational goals. In doing so, the college develops culturally competent students with the knowledge, skills, and values that prepare them to be productive members of their local and global communities.*

## SERVING THE COMMUNITIES OF

Artesia, Bellflower, Cerritos, Downey,  
Hawaiian Gardens, La Mirada, Norwalk



## AND PORTIONS OF

Bell Gardens, Lakewood, Long Beach,  
Santa Fe Springs, South Gate

## CERRITOS COMMUNITY COLLEGE DISTRICT ADMINISTRATION

JOSE L. FIERRO, D.V.M., Ph.D.  
President/Superintendent

RICK MIRANDA  
Vice President of Academic Affairs/Assistant Superintendent

FELIPE R. LOPEZ  
Vice President of Business Services/Assistant Superintendent

ADRIANA FLORES-CHURCH, Ed.D  
Vice President of Human Resources/Assistant Superintendent

DILCIE PEREZ, Ed.D  
Vice President of Student Services/Assistant Superintendent

## BOARD OF TRUSTEES

MARISA PEREZ  
President

MARTHA CAMACHO-RODRIGUEZ  
Vice President

JAMES CODY BIRKEY  
Clerk

CARMEN AVALOS  
Member

ZURICH LEWIS  
Member

DR. SHIN LIU  
Member

DR. SANDRA SALAZAR  
Member

JOHNNY WALLACE  
Student Trustee

In accordance with the Americans with Disabilities Act, this information is available in alternate formats (Braille, enlarged type, e-text, etc.) and may be requested by calling (562) 860-2451, Ext. 2335.

# ALPHABETICAL TABLE OF CONTENTS

## Cerritos Community College District

Academic Information . . . . .	20-22
Admission and Enrollment of Dual Enrolled Minors . . . . .	30
Admission and Orientation . . . . .	6, 7
Adult Education Non-Credit Classes . . . . .	104-109
Alcohol and Drug Policy . . . . .	158
(ASCC) Associated Students of Cerritos College Rights/Responsibilities/Policies . . . . .	146-157
Attendance and Grading . . . . .	28
Auditing of Courses . . . . .	22
Calendar of Important Dates . . . . .	3
Campus Map . . . . .	161
Campus Phone Extensions . . . . .	159
Chicano Studies . . . . .	110
Class Listings . . . . .	32-103
Counseling and Follow-up . . . . .	9
Course Listings . . . . .	162
Course Repeatability . . . . .	26-27
Credit by Exam . . . . .	23
Distance Education Courses . . . . .	115-130
Enrollment Instructions . . . . .	15
Enrollment Appointment Priority . . . . .	4-5
Family Educational Rights and Privacy Act (FERPA) . . . . .	132
Fees/Refund Information and Procedures . . . . .	19
Final Exam Schedule . . . . .	160
Financial Assistance . . . . .	29
General Education Requirements for the AA Degree and for Transfer to the CSU and UC . . . . .	133-139
Información en Español . . . . .	10-14, 143
International Student Services . . . . .	31
Learning Communities . . . . .	113-114
Pass/No Pass Classes . . . . .	24-25
Paying your Fees . . . . .	16
Reading the Class Schedule . . . . .	18
Scholars' Honors Program . . . . .	111
Self-Report Tool (SRT)/Placement . . . . .	8
Services for Students . . . . .	140-142
Sexual and Gender-Based Misconduct . . . . .	131
Student Accessibility Services . . . . .	144
Student Services and Policies . . . . .	146-157
Student Success and Support Program (SSSP) . . . . .	4-6
Success Center . . . . .	145
Transfer Center Timeline . . . . .	163
Wait List . . . . .	17
Women's and Gender Studies . . . . .	112

## CLASS SCHEDULE

32 – 103

### GENERAL CLASS LISTINGS

- General Class Listings 32-97
- Short-Term Classes 98-103

104 – 109

### ADULT EDUCATION NON-CREDIT CLASSES

- Apprenticeship Programs  
Firesprinklers, Painters, and Ironworkers
- Pre-Apprenticeship
- Adult Education
  - ESL
  - VESL
  - Basic English (College English Skills)
  - Basic Math (Preparatory Mathematics)
  - High School Equivalency
  - Literacy Skills for General Education  
Development (GED) Success
  - Supplemental General Education  
Development (GED) Math
  - Spanish Literacy Skills for General  
Education Development (GED) Success
  - Spanish Supplemental General  
Education Development (GED) Math
  - Occupational Preparation
  - Citizenship
  - College Math Support
  - College English Support
- Introduction to Energy Surveying
- Introduction to Automotive Tools and  
Equipment
- Courses for Older Wiser Learner
- Plaza Community (Spanish Literacy)

113 – 114

### LEARNING COMMUNITIES

115 – 130

### DISTANCE EDUCATION COURSES

*From science to technology to  
the humanities, at Cerritos College,  
our focus is teaching, learning  
and academic excellence.*

If you have questions or need information in Spanish about Cerritos College, please call the Admissions and Records Office at (562) 860-2451, extension 2211. Office hours are Monday through Thursday, 8 am – 7 pm; Friday, 8 am – 2 pm. Additional information is available in Spanish on pages 10-14 and 143.

Si usted tiene preguntas o necesita información en español acerca del Colegio de Cerritos, llame por favor a la Oficina de Admisiones y Registro al número (562) 860-2451, extensión 2211. El horario de oficina es Lunes a Jueves, 8 am – 7 pm; Viernes, 8 am – 2 pm. Información adicional está disponible en español en las páginas 10-14 y 143.

# FALL 2020 CALENDAR OF IMPORTANT DATES

## ENROLLMENT BEGINS JUNE 8, 2020

For information on assignment of enrollment priorities, please refer to the section titled, "Enrollment Appointment Priority" in this schedule of classes.

### MYCERRITOS ENROLLMENT HOURS:

Monday – Sunday	12 am – 12pm
Sunday	8 am – midnight

### MYCERRITOS APPLICATION HOURS:

Monday – Sunday	12 am – 12pm
-----------------	--------------

### ADMISSIONS AND RECORDS OFFICE FEE PAYMENT HOURS:

Monday – Thursday	8 am – 6:30 pm
Friday	8 am – 11:30 am

**Session Dates and Deadlines are now available online at:**  
[cms.cerritos.edu/admissions-and-records/add-drop-dates](https://cms.cerritos.edu/admissions-and-records/add-drop-dates)

### IMPORTANT DATES:

First day to file a petition for A.A. Degree and Certificate for Fall 2020	August 17
Labor Day Holiday	September 7
Last day to file petition for A.A. Degree and Certificate for Fall 2020	September 13
Veterans Day Holiday	November 11
Thanksgiving Recess	November 26 – 29
Final Exams	December 14 – 18

### CERRITOS COLLEGE OFFERS APPLICATION AND ENROLLMENT VIA THE WEB.

#### For Online Submission of Admissions Applications:

Visit [www.cerritos.edu](http://www.cerritos.edu). Click on "Apply Now" in the yellow box in the upper right corner.

#### For Online Enrollments:

Visit [www.cerritos.edu](http://www.cerritos.edu). Under the "Current Students" section, click on "MyCerritos". Then, click on "Student Center"; or, using Quick Links, click on "MyCerritos", log in, and click on "Student Center" to continue.

\*An application must be submitted for new, returning, and transfer students prior to enrollment. For continuing students, a user ID number (7-digit student ID-example 0123456) and Password (6-digit date of birth-mmddyy) are required.

### EMERGENCY INFORMATION

In the event of an emergency, the Cerritos College Emergency Information web page (<http://www.cerritoscollege.us/>) may be used to secure updated information about any emergency event occurring on the Cerritos College campus. The College also offers an SMS-based emergency notification service for mobile phones. In the event of an emergency, Cerritos students, staff, faculty, and others will be alerted in real-time to important security information. You may sign-up for Emergency Text Alerts by texting the keyword "CERRITOS" to 226787.

### DISCLAIMER

Cerritos College has made reasonable efforts to ensure the accuracy of the information contained in this Schedule of Classes at the time of publication. The College reserves the right to add to, amend, or repeal any of the rules, regulations, policies and procedures, or any other content, consistent with applicable regulations and laws. Content is subject to change without notice by the administration for reasons of student enrollment, level of financial support, or for any other reason at the discretion of the College. The Schedule of Classes does not constitute a contract or the terms of a contract. The Schedule of Classes is not intended to promulgate all policies, procedures, rules, and regulations of partner organizations, transfer institutions, the College, or the Cerritos Community College District. Students are advised to consult the online version of this schedule of classes and to contact Counseling Services or the applicable administrative office for additional information.

### ANNUAL SECURITY REPORT

Cerritos College publishes an Annual Security Report in accordance with the Clery Act. This report includes statistics for the previous three years concerning reported crimes that occurred on-campus; in certain off-campus buildings or property owned or controlled by Cerritos College; and on public property within, or immediately adjacent to and accessible from, the campus. This report also includes institutional policies concerning campus security, such as policies concerning sexual assault, and other matters. You can obtain a copy of this report by contacting the Campus Police Department in person or at (562) 860-2451, extension 3202. This report is also available on the college website at [www.cerritos.edu/securityreport](http://www.cerritos.edu/securityreport).

# STUDENT SUCCESS AND SUPPORT PROGRAM (SSSP)

**Information is also available in Spanish on pages 10-14.**

**Información en español también está disponible en las páginas 10-14.**

## STUDENT RIGHTS AND RESPONSIBILITIES

- (a) All students shall be required to:
  - (1) identify an education and career goal;
  - (2) diligently engage in course activities and complete assigned coursework; and
  - (3) complete courses and maintain progress toward an education goal and completing a course of study.
- (b) Nonexempt first-time students shall, within a reasonable period of time, be required to:
  - (1) identify a course of study;
  - (2) be assessed to determine appropriate course placement;
  - (3) complete an orientation provided by the college;
  - (4) participate in counseling, advising, or another education planning service to develop an abbreviated student education plan (A-SEP).
- (c) For the purposes of this section, a first time student is a student who enrolls at the college for the first time, excluding students who transferred from another institution of higher education. For the purposes of this section, first time enrollment does not include concurrent enrollment during high school. To the extent that a college has the capacity to require and provide the services identified in (b)(1) through (4) to other students, nothing in this section would preclude a college from doing so.
- (d) Nonexempt students who have completed the services identified in (b)(1) through (4) shall be required to complete a comprehensive student education plan (C-SEP) after completing 15 semester units of degree applicable credit course work or prior to the end of the 3rd semester, or a shorter period if required by district or program policy.
- (e) Failure to fulfill the required services listed in (b) may result in a hold on a student's registration or loss of registration priority until the services have been completed.

## INSTITUTIONAL RESPONSIBILITIES

- (a) The college shall take steps to ensure that information regarding matriculation policies is accessible and available to all students during, or prior to, enrollment (e.g. during orientation) and is included in class schedules, catalogs, or other appropriate communications describing student rights and responsibilities.
- (b) Once the student has identified a course of study and completed 15 semester units of degree applicable course work, the college shall provide the student with an opportunity to develop a comprehensive student education plan (C-SEP) within a reasonable time period. Student responsibilities shall also be identified in the student's education plan.
- (c) College policy provides that a nonexempt student will have a hold placed on enrollment if a student fails to fulfill the responsibilities set forth in the section, "Student Rights and Responsibilities".
- (d) The college shall make reasonable efforts to avoid duplication of the orientation, assessment, counseling, advising, or other education planning services, and development of student education plans funded through this subchapter or funded through other programs.

- (e) It is intended that the instructional and student services area of the college shall use multiple sources of data from student education planning efforts and identified courses of study to coordinate course scheduling.

## ENROLLMENT APPOINTMENT PRIORITY

**including Orientation, SRT, Counseling, Student Education Plans, Tier Groups, Probation**

The purpose of establishing enrollment priorities is to support students endeavoring to reach their educational goals at Cerritos College by providing priority enrollment to groups of students (as listed herein) with special needs and/or who are in continuing student status, as long as satisfactory progress is made.

## PRIORITY ENROLLMENT CRITERIA AND CONDITIONS

- A. Priority
  1. New students not otherwise exempt, including those in any state-provided priority enrollment groups, must complete SRT, orientation, and counseling with at least an abbreviated student education plan (A-SEP), in order to receive priority enrollment.
  2. First-time students, beginning with Spring 2020 enrollment, who have identified a course of study, been assessed to determine appropriate course placement, completed an orientation program provided by the college, and participated in counseling, advising, or another education planning service including at least an abbreviated student education plan (A-SEP), are required to complete a comprehensive student education plan (C-SEP) after completing 15 units of degree-applicable credit course work, or prior to the end of the 3rd semester of enrollment, resources permitting.
  3. Continuing students, including those in any state-provided priority enrollment groups, except eligible current and former foster youth, are subject to loss of the enrollment priority for which they would ordinarily be eligible if they are on any combination of progress or academic probation for two consecutive semesters.
  4. Continuing students, including those in any state-provided priority enrollment groups, except eligible current and former foster youth, are subject to loss of the enrollment priority for which they would ordinarily be eligible if they have earned 100 degree-applicable, non-basic skills and non-ESL units. Units for high unit majors and programs may be disregarded to the extent they exceed the number of units required for non-high unit majors and programs. Units from Credit by Exam, Advanced Placement, International Baccalaureate, or other similar programs may also be exempted.
- B. Subject to the above, continuing student enrollment appointments shall be set on the basis of units earned and cumulative grade point average at Cerritos College.
- C. Students subject to enrollment priority exclusion shall have a "PRB" negative service indicator, appearing as a Hold in the Student Center in MyCerritos, placed on their enrollment account. The effect shall be to place the student's access to enroll at the end of the enrollment cycle in the period known as Open Enrollment.

# STUDENT SUCCESS AND SUPPORT PROGRAM (SSSP)

- D. Students excluded from enrollment priority shall be notified of options they may have, and/or are advised to exercise. See also the section of this procedure titled "Appeals and Exemptions".

## **Additional Criteria for Enrollment Priority of Certain Students**

- A. Students who are otherwise specified by statute.
- B. Students whose instructional program requires time off-campus or blocks of time associated with scheduled classes for such activities as practice, meetings, counseling, and off-campus time, which limit the choice of class periods.

## **STUDENT GROUPS WITH PRIORITIES:**

**Tier 1:** Enrollment appointments for students in Tier 1 groups shall be set tier-wide based on units earned and cumulative grade point average, consistent with applicable regulations.

**Armed Forces Personnel and Recent Veterans:** Students who are any member or former member of the Armed Forces of the United States, who is a resident of California, for any academic term, within four years of leaving active duty (Education Code Section 66025.8).

**CalWORKs:** Students formally enrolled in the CalWORKs Program (Education Code Section 66025.92).

**EOPS:** Students formally enrolled in Extended Opportunity Programs and Services (Education Code Section 66025.91).

**Foster Youth:** Students formally deemed eligible current or former foster youth who are up to and including 24 years of age (Education Code Section 66025.9).

**SAS:** Students who, by their specific disabilities, are enrolled in Student Accessibility Services (Education Code Section 66025.91).

**Tier 2:** Enrollment appointments for students in Tier 2 groups shall be set tier-wide based on units earned and cumulative grade point average, consistent with applicable regulations.

**Scholars' Honors Students:** Students who have been officially admitted to the College's Scholars' Honors Program each term and are currently enrolling in Scholars' Honors Program courses and/or Scholars' Honors contracts.

**Student Athletes:** Students who have been identified as eligible to participate in intercollegiate athletics.

**Mandatory Enrollment Requirement Students:** Students in compliance with program requirements who must maintain full-time status, with completion time requirements, in order to remain in Cerritos College programs and/or who are in grant-funded programs with enrollment priority requirements.

**Matriculated Students:** Students who, prior to their first semester of enrollment, completed the Admission, Orientation, Assessment, and Counseling components of Matriculation.

**Trial, Grant-funded, or Other Special Groups for Student Success:** Students in groups identified for enhanced and/or expedited student success measures where trial, grant-funded, and/or other special, short-term measures are employed.

**Tier 3:** Enrollment appointments for students in Tier 3 groups shall be set in the order of the groups as listed and based on units earned and cumulative grade point average within those groups, consistent with applicable regulations.

**Continuing Students:** Students who were enrolled in the previous academic year or summer session. Students who do not attend summer session will not lose continuing student status. The definition includes non-credit students who are matriculating to credit student status.

**Returning Students:** Students who have completed at least one unit of credit at Cerritos College and are returning after a break of no more than one semester excluding summer session.

**Tier 4:** Enrollment appointments for students in Tier 4 groups shall be set in the order of the groups as listed and based on units earned and cumulative grade point average within those groups, consistent with applicable regulations.

**Dual Enrollment:** High school juniors and seniors, as provided for and limited in, Board Policy 5010 titled "Admissions and Concurrent Enrollment" and Administrative Procedure 5011 titled "Admission and Concurrent Enrollment of High School and Other Young Students".

**Dual Enrollment (Grades K-10):** Talented elementary and secondary students through the 10th grade, as provided for and limited in, Board Policy 5010 titled "Admissions and Concurrent Enrollment" and Administrative Procedure 5011 titled "Admission and Concurrent Enrollment of High School and Other Young Students".

## **ENROLLMENT LIMITATIONS**

Enrollment in courses and programs may be limited to students meeting properly established prerequisites and co-requisites (See Board Policy and Administrative Procedure 4260 titled "Prerequisites and Co-requisites").

### **Additional Enrollment Limitations (including, but not limited to):**

- A. Health and safety considerations;
- B. Faculty workload;
- C. Availability of qualified instructors;
- D. Funding limitations;
- E. Regional planning;
- F. Legal requirements;
- G. Facility limitations; and
- H. Accreditation, regulatory, and policy requirements.

### **Priorities When Enrollment Must be Limited**

- A. First come, first served, or other non-evaluative selection techniques, provided all prerequisite and/or course requisites have been met;
- B. In the case of intercollegiate competition, honors courses, or public performance courses, allocating available seats to those students judged most qualified;
- C. Limiting enrollment to any selection procedure expressly authorized by statute; and
- D. Limiting enrollment in one or more sections to students enrolled in one or more other courses, provided that a reasonable percentage of all sections of the course do not have such restrictions.

### **Additional Conditions May Be Applicable to Order of Enrollment**

Course sections funded other than by state apportionment, such as contract education, grant-funded programs, and certain fee-based sections (as permitted by law).



# STUDENT SUCCESS AND SUPPORT PROGRAM (SSSP)

## LOSS OF ELIGIBILITY FOR CCPG FEE WAIVER

A student shall become ineligible for a California College Promise Grant (CCPG) Fee Waiver if the student is placed on academic or progress probation, or any combination thereof, for two consecutive primary terms. Loss of eligibility shall become effective at the first registration opportunity after such determination is made.

The District shall notify students of their placement on academic or progress probation no later than 30 days following the end of the term that resulted in the student's placement on probation. The notification must clearly state that two consecutive primary terms of probation will lead to a loss of the CCPG Fee Waiver until the student is no longer on probation. The notification must also advise students about the available student support services to assist them in maintaining eligibility.

The District shall adopt, prominently display, and disseminate policies ensuring that students are advised about the student support services available to assist them in maintaining and re-establishing CCPG Fee Waiver eligibility. Dissemination includes, but is not limited to, information provided in college catalogs and class schedules.

The District shall establish written procedures by which a student may appeal the loss of a CCPG Fee Waiver due to extenuating circumstances, or when a student with a disability applied for, but did not receive, a reasonable accommodation in a timely manner. Extenuating circumstances are verified cases of accidents, illnesses, or other circumstances that might include documented changes in the student's economic situation or evidence that the student was unable to obtain essential student support services. Extenuating circumstances also include special consideration of the specific factors associated with Veterans, CalWORKs, EOPS, and SAS student status.

Foster Youth shall not be subject to loss of CCPG Fee Waiver due to placement on academic or progress probation. This exemption for Foster Youth is effective until the date specified in the Education Code, section 66025.9(c).

## APPEALS AND EXEMPTIONS

It is the intent of these procedures to support and promote student success, including program completion, through access to needed courses. Petitions for appeals of, or exemption from, the implementation of these procedures are subject to consideration by the Committee on Academic Records and Standards (A&S) or its designee.

- A. Students may appeal the loss of enrollment priority and/or loss of the CCPG Fee Waiver due to extenuating circumstances, certain conditions specified on the Enrollment Priorities and/or the CCPG Fee Waiver Appeals Form, or where a student with a disability applied for, but did not receive reasonable accommodation in a timely manner. Extenuating circumstances are verified cases of accidents, illnesses, or other circumstances beyond the control of the student.
- B. Students who have demonstrated significant academic improvement will regain the CCPG Fee Waiver and/or priority enrollment status. It is the student's responsibility to timely verify changes in enrollment priority status. Significant academic improvement is defined as achieving no less than the minimum grade point average and progress standard within a term. The minimum academic standard is a 2.0 grade point average, once the student has attempted 12 semester units; the minimum progress standard is greater than 50% of all units enrolled in being other than "W", "I", "NP", or "NC", once the student has enrolled in a total of at least 12 semester units.
- C. Students may request reinstatement of enrollment priority and/or the CCPG Fee Waiver if an institutional mistake was made.

## ADMISSION AND ORIENTATION

### ASSESSMENT AND ORIENTATION-COUNSELING ARE REQUIRED FOR FIRST-TIME, NEW-TO-COLLEGE STUDENTS.

#### ADMISSION

##### *Who May Apply for Admission?*

- Anyone who is a high school graduate or at least 18 years of age who may benefit from instruction.
- High school students in their junior or senior year with appropriate Dual Enrollment approval forms.
- International Students in valid, non-immigrant, F-1 visa status.

##### *How to Apply for Admission*

- Students who are enrolling for the first time or who are returning after an absence of one or more semesters, must complete an admissions application as early as possible prior to the start of enrollment (proof of residence may be required). The admission application is available on the college website at [www.cerritos.edu](http://www.cerritos.edu), "Apply Now".
- **International students who are outside the U.S. seeking I-20 and inside the U.S. with F-1 visa status planning to transfer to Cerritos College.** International students must submit an International Student application, meet specific admission requirements, and pay a \$50 processing fee. Please see page 30 for admission requirements.

*Prerequisites are strictly enforced by MyCerritos enrollment. Read your course selections carefully for all requirements. Requisites may be fulfilled by:*

- *Completing placement tests and enrolling in the recommended courses, and/or*
- *Completing the prerequisite course with a grade of Pass, or "C" or higher.*

*OR*

- *By submitting transcripts to the Admissions and Records Office if a prerequisite course was completed at another college.*

*Requisite Clearance forms for consideration for the current semester should be submitted two weeks prior to the start of enrollment.*

# ADMISSION AND ORIENTATION

## FALCON EDGE ORIENTATION

**Self-Report Tool (SRT)/Placement and Orientation-Counseling are required for all first-time, new-to-college students.** Transfer students are also highly encouraged to complete orientation.

**Self-Report Tool (SRT)/Placement and Orientation-Counseling** Placement and orientation counseling are required for first-time, new-to-college students. Two holds will appear in the MyCerritos account of these students: one hold for SRT/Placement (ASM) and one hold for Orientation-Counseling (ORI). **Enrollment in classes will not be allowed until these requirements are met.** Students not required to complete the established criteria are automatically exempt upon application to the College.

### Early Success Program (ESP)

Cerritos College offers the **Early Success Program (ESP)** during the fall and spring semesters. This program is designed to encourage early completion of SRT/Placement and Orientation-Counseling. By completing SRT/Placement and Orientation-Counseling prior to the established deadline, first-time college students receive an earlier enrollment appointment date. For more information, visit [www.cerritos.edu/esp](http://www.cerritos.edu/esp).

### Options for Falcon Edge Orientations

#### Online

Start, stop, and restart anytime! Go to [www.cerritos.edu](http://www.cerritos.edu), log in to MyCerritos, and click *Cerritos College Falcon Edge Orientation*.

#### On campus

A limited number of orientations are offered, including day and evening, prior to the start of each term. Call the Counseling Office at (562) 467-5231, or go online to [www.cerritos.edu/aoc](http://www.cerritos.edu/aoc), for more information.



## STUDENT ACTIVITY STICKER AND IDENTIFICATION CARD

ASCC utilizes the revenue collected from the Student Activity fee to support academic, extra-curricular, and student life programs, services, and events.

For more information contact the Admissions & Records Office at [admissions-info@cerritos.edu](mailto:admissions-info@cerritos.edu).

# SELF-REPORT TOOL (SRT)/PLACEMENT

## WHAT IS THE PLACEMENT PROCESS?

Placement is required for first-time, new-to-college students. “Placement” means the process of gathering information about an individual student to facilitate his or her success. At Cerritos College, the process includes, but is not limited to, the collection of information regarding a student’s study skills, English language proficiency, and/or computational skills. Academic counselors will review high school and/or college transcripts, evidence of an A.A. degree or higher from an accredited institution, learning skills, academic performance, and need for special services.

## DO I NEED TO COMPLETE THE PLACEMENT PROCESS?

All students will have the opportunity to place into transfer-level English/ESL and Math.

By using high school records or guided self-placement, new and continuing students will identify the English/ESL and Math courses they are eligible to enroll in.

First-time, new-to-college students are required to complete the placement process prior to enrollment. Continuing students who previously received a placement based upon an assessment test are welcome to complete this new placement process.

Depending on when, where or if students attended high school, they will complete either the Self-Report Tool (SRT) or Guided Placement Tool (GPT), which, in most cases, will place students directly into transfer level courses in the areas of math and English or ESL.

How do you complete the SRT/GPT? To access the SRT or GPT, students can log in to their MyCerritos account. The links are located on the right side of the screen under “Placement.” For those who prefer to complete the SRT or GPT in person, visit the Assessment Center in MP 206 to get started. A current Cerritos College student number and photo ID is required when completing the SRT/GPT in person.

Students with a history of special education are encouraged to seek additional course placement guidance from counselors in Student Accessibility Services. Visit <http://www.cerritos.edu/sas> for more information.

## STUDENT SUCCESS & SUPPORT PROGRAM (SSSP) EXEMPTION/EXCEPTION

Cerritos Community College offers Student Success and Support Services to all new students prior to their enrollment in classes. These services include placement, orientation, and counseling. First-time, new-to-college students must complete required SRT/Placement and Orientation-Counseling prior to enrollment. Students not required to complete the requirements under established criteria are automatically exempt upon application to the College. Students wishing to pursue another type of exemption must submit a completed Student Success and Support Program (SSSP) Exemption and Exception form to the Admissions and Records Office. SSSP Exemption and Exception forms are available in the Admissions and Records, Assessment, and Counseling Offices. If you have special needs for completing SRT/ placement, orientation, or counseling; please contact the Assessment Office or Student Accessibility Services.

## SELF-REPORT TOOL (SRT)/PLACEMENT EXEMPTIONS

Students who already possess an AA degree or higher from a regionally accredited college are not required to complete the Self-Report Tool (SRT)/ placement process, but will be required to verify the degree by presenting official documents to the Admissions and Records Office at least 10 working days prior to their enrollment appointment date. A Requisite Clearance form must accompany the documents in order to meet prerequisites.

## PLACEMENT EXEMPTIONS FOR:

**English** – Students who have completed English courses at another college may not need to complete the English Self-Report Tool. Please submit proof (official or unofficial transcripts) and a Requisite Clearance form to a counselor or Admissions and Records prior to enrollment.

**Math** – Students who have completed math courses at another college also may not need to complete the math Self-Report Tool. Please submit proof (official or unofficial transcripts) and a Requisite Clearance form to a counselor or Admissions and Records prior to enrollment. It is strongly recommended that these math courses have been completed within the past 10 years.

**Advanced Placement Exams** – Students who participate in advanced placement courses at their high schools and earn passing scores on AP exams may earn college credit for those courses when they come to Cerritos College. For further details, ask a counselor.

**Chemistry** – Please read the prerequisites and recommendations section with each chemistry class listing. Be sure that the prerequisites are satisfied before enrolling in a course.

*Please note: The exceptions listed are assessment/placement options for course clearance or placement. To meet the required reading, math, and English proficiencies necessary to qualify for the Associate in Arts degree, check your catalog or ask a counselor.*

## ACCOMMODATION FOR ENGLISH AS A SECOND LANGUAGE

Students planning to take ESL (English as a Second Language) courses will also complete the Self-Report Tool (SRT)/Guided Placement Tool. Based upon your experience, skills and confidence using English in your work and daily life, you will receive your placement recommendation for instruction in the appropriate English or ESL course.

## RETEST POLICY

Students who have completed the ACCUPLACER test and wish to retest, will now complete the Self-Reporting Tool (SRT). Students who have completed high school within the last 10 years, will receive course recommendations based on their United States high school records. Based on the cumulative and unweighted United States high school GPA and other academic-related questions, students may be placed directly into transfer level courses in the areas of English, reading, math, or ESL. A current Cerritos College student number and photo ID are required to complete the SRT, which is computerized. For students who completed high school more than 10 years prior to applying to the college, completed the GED or did not complete high school, or are an international student, please contact the Assessment Office for information pertaining to your specific situation.

## PLACEMENT SCHEDULE

The schedule for the Assessment Office is available on the Cerritos College Assessment Office web page, [www.cerritos.edu/assessment-center](http://www.cerritos.edu/assessment-center), or call (562) 860-2451, x2599. To insure you have the most current schedule, please refer to the office’s web page, as the schedule is subject to change.

## ACCOMMODATION FOR STUDENTS WITH DISABILITIES

Any student with a verified disability may arrange accommodations for the placement process. A current Cerritos College application must be on file to receive accommodations. Accommodations requests should be made at least 7 days in advance to Student Accessibility Services (SAS). For more information or an appointment, call (562) 860-2451, ext. 2335; (562) 274-7164 (VP); or visit our website at [www.cerritos.edu/sas](http://www.cerritos.edu/sas). Academic Accommodations may include, but are not limited to: readers, writers, or the use of assistive technology.

# COUNSELING AND FOLLOW-UP

## COUNSELING

- All students new to college are required to complete a Falcon Edge Orientation to receive counselor assistance for course selection prior to enrollment. See the "Falcon Edge Orientation" section for more information on required SRT/Placement and Orientation-Counseling. Returning and transfer students are also encouraged to see a counselor.
- Counselors are available both in person and virtually for appointments, or standby/drop-in.
- Students may submit a general question to a counselor online at [www.cerritos.edu/counseling](http://www.cerritos.edu/counseling).
- Plan ahead – appointments and standby/drop-in counseling may be limited during peak registration.
- Once the semester begins, new, readmit, and transfer students are highly encouraged to make a counseling appointment or attend an Ed Plan workshop to discuss educational goals and to complete a Comprehensive Student Educational Plan (C-SEP).
- Continuing students are encouraged to meet with a counselor every semester to ensure their educational plan accurately reflects their educational goal. Schedule an appointment or sign up for an Ed Plan workshop at the Counseling desk, or call (562) 467-5231.
- Students who are on academic and/or progress probation will be limited in the number of units they may take each semester based upon their GPA and course completion. They also risk losing their enrollment priority appointment and, as of Fall 2016, may be ineligible for the California College Promise Grant Fee Waiver (CCPGFW) if they remain on probation for two consecutive semesters.

## FOLLOW-UP

Counseling and teaching faculty provide a number of follow-up services to students. These services are designed to provide information regarding the students' academic progress. Special services are provided to students on academic and/or progress probation, students in basic skills courses, and students who are undecided about their educational goal. Referrals are made to on and off-campus services when appropriate.

### NEW STUDENT

You are a new student if this is the first time you are attending any college. You are required to complete Self-Report Tool (SRT)/Placement and Orientation-Counseling prior to enrollment.

### TRANSFER STUDENT

You are a transfer student if you attended another college but have never attended Cerritos College.

### RETURNING STUDENT

You are a returning student if you have previously attended Cerritos College but did not attend the 2020 Spring semester.

### CONTINUING STUDENT

You are a continuing student if you were enrolled in credit classes at Cerritos College during the 2020 Spring semester.

### DUAL ENROLLMENT STUDENT (K-12)

Concurrent enrollment for students who wish to attend Cerritos College while in grades K-12.

## BASIC SKILLS COURSE LIMITATIONS

No more than a total of thirty (30) units from the pre-collegiate basic skills courses listed below are allowed:

ENGL 20

MATH 20, 40

READ 41, 42, 43, 46, 48, 49

"Basic skills course work" refers to pre-collegiate basic skills courses (i.e. courses in reading, writing, computation, learning skills, study skills) that are designated as non-degree applicable courses, the purpose of which is to prepare students for successful completion of an Associate in Arts degree, transfer, or certification courses.

Students enrolled in one or more courses of English as a Second Language (ESL) or students identified as having a learning disability are exempt from the thirty (30) unit limitation. A student who has completed thirty (30) units of basic skills course work shall be barred from enrolling in pre-collegiate basic skills classes and referred to other agencies to develop the skills necessary to enter college-level course work.

## Open Courses

All courses, course sections, and classes of the College shall be open for enrollment to any person who has been admitted to the College. Enrollment shall be limited to students meeting properly validated prerequisites and co-requisites. Exemptions for state or federal statutes or regulations shall be established and the President/Superintendent shall establish procedures to establish exemptions for other practical considerations.

**BUY YOUR  
BOOKS  
WHEN YOU  
ENROLL!**

Now you can buy your textbooks during the enrollment process. Just click the "buy books" button in MyCerritos on either of two screens: one when you "Add Classes" and another on "My Class Schedule". The button links to the Cerritos College Bookstore's eFollett website and presents a list of items (if available) that directly relate to your enrolled classes for the term.

# INFORMACIÓN EN ESPAÑOL

## PROGRAMAS DE APOYO Y ÉXITO DEL ESTUDIANTE (Student Success and Support Programs, SSSP), anteriormente Matriculación

### DERECHOS Y RESPONSABILIDADES DE LOS ESTUDIANTES

- (a) Se debe requerir a los estudiantes que:
  - (1) Identifiquen una meta educativa y profesional.
  - (2) Participen diligentemente en las actividades del curso y completen los trabajos asignados.
  - (3) Completen los cursos y mantengan el progreso hacia un objetivo educativo y concluyan un curso de estudio.
- (b) Los estudiantes de primer ingreso no exentos en un plazo de tiempo razonable, deberán:
  - (1) Identificar un curso de estudio.
  - (2) Realizar una evaluación para determinar la colocación en el curso apropiado.
  - (3) Completar una orientación que establece la universidad.
  - (4) Participar en la consultoría, asesoría u otro servicio de planificación de la educación para desarrollar un plan educativo abreviado.
- (c) A los efectos de esta sección, un estudiante de primer ingreso es un estudiante que se inscribe en la universidad por primera vez, salvo los estudiantes que se transfieren de otra institución de educación superior. Para los propósitos de esta sección, la inscripción por primera vez no incluye la inscripción simultánea cuando todavía se asiste a la escuela secundaria. En la medida en que una universidad tenga la capacidad de exigir y proporcionar los servicios indicados en (b)(1) a (4) a otros estudiantes, nada de lo incluido en esta sección impedirá a la universidad hacerlo.
- (d) Los estudiantes no exentos que hayan cumplido con los servicios identificados en (b)(1) a (4) estarán obligados a terminar un plan de formación integral (C-SEP) después de completar 15 unidades semestrales de los cursos con créditos aplicables al grado académico o antes de finalizar el tercer semestre, o bien en un período más corto si lo requiere una política del programa o del distrito.
- (e) El incumplimiento de realizar los servicios requeridos que se enumeran en (b) puede resultar en una retención del registro del estudiante o la pérdida de la prioridad de inscripción hasta que los servicios se hayan completado.

### RESPONSABILIDADES INSTITUCIONALES

- (a) La universidad tomará las medidas necesarias para garantizar que la información sobre las políticas de matriculación sea accesible y está disponible para todos los estudiantes, durante, o antes de, la inscripción (por ejemplo, durante la orientación) y se incluye en los programas de clase, catálogos u otras comunicaciones apropiadas que describen los derechos y las responsabilidades de los estudiantes.
- (b) Una vez que el estudiante ha identificado un curso de estudio y completó 15 unidades semestrales de trabajo del curso aplicables al grado académico, la universidad debe proporcionarle la oportunidad de desarrollar un plan educativo (C-SEP) integral en un plazo razonable. Las responsabilidades estudiantiles también deberán determinarse en el plan de educación del estudiante.
- (c) La política de la universidad establece que un estudiante no exento tendrá una retención de la matrícula si no cumple con las responsabilidades establecidas en la sección “Derechos y responsabilidades de los estudiantes”.

- (d) La universidad hará esfuerzos razonables para evitar la duplicación de la orientación, evaluación, consultoría, asesoría u otros servicios de planificación de la educación y el desarrollo de los planes educativos financiados a través de este subcapítulo o por medio de otros programas.
- (e) Se pretende que el área de servicios estudiantiles y de enseñanza de la universidad utilice diferentes fuentes de datos sobre los esfuerzos de planificación de la educación de los estudiantes y cursos identificados de estudio para coordinar la programación de los cursos.

### PRIORIDAD DE LA CITA DE INSCRIPCIÓN

#### ***incluye la orientación, evaluación, consultoría, planes educativos, grupos de nivel, período de prueba***

El propósito de establecer prioridades de inscripción es apoyar a los estudiantes que se esfuerzan por alcanzar sus metas educativas en Cerritos College, proporcionando prioridad de inscripción a grupos de estudiantes (que se enumeran en este documento) con necesidades especiales o que están en condición de estudiantes de reingreso, siempre y cuando el progreso sea satisfactorio.

### CRITERIOS Y CONDICIONES PARA LA PRIORIDAD DE INSCRIPCIÓN

- A. Prioridad
  - 1. Los nuevos estudiantes que no se encuentran exentos de otra manera, entre ellos los que son parte de grupos con prioridad de inscripción que establece el estado, deben completar la evaluación, orientación y consultoría con por lo menos un plan educativo abreviado (A-SEP), a fin de recibir prioridad de inscripción.
  - 2. La primera vez, a partir de la inscripción en el otoño de 2014, los estudiantes que han identificado un curso de estudio, se han evaluado para determinar la colocación apropiada de cursos, completaron un programa de orientación que proporciona la universidad y han participado en la consultoría, asesoría u otro servicio de planificación de la educación que incluye, al menos, un plan educativo abreviado (A-SEP), están obligados a completar un plan educativo integral (C-SEP) después de completar 15 unidades semestrales de los cursos con créditos aplicables al grado académico o antes de finalizar el tercer (3.er) semestre de inscripción, según lo permitan los recursos.
  - 3. Los estudiantes de reingreso, incluidos los de algún grupo con prioridad de inscripción que establece el estado, salvo los jóvenes de crianza actual y anterior que son elegibles, están sujetos a la pérdida de la prioridad de inscripción para los que ordinariamente serían elegibles si están en cualquier combinación de progreso o probatoria académica para dos semestres consecutivos.
  - 4. Los estudiantes de reingreso, incluidos los de algún grupo con prioridad de inscripción que establece el estado, salvo los jóvenes de crianza actual y anterior que son elegibles, están sujetos a la pérdida de la prioridad de inscripción para la que ordinariamente serían elegibles si han obtenido 100 destrezas no básicas aplicables al grado académico y que no son unidades del programa ESL. Las unidades para asignaturas y programas principales podrán ignorarse en la medida en que superen el número de unidades requeridas para asignaturas y programas que no son principales. Las unidades de crédito por examen, colocación avanzada, Bachillerato Internacional u otros programas similares también pueden estar exentos.

- B. Sin perjuicio de lo anterior, las citas de matrícula de los estudiantes de reingreso se establecerán con base en las unidades o el promedio de calificaciones acumuladas en Cerritos College.
- C. Los estudiantes que están sujetos a la exclusión de prioridad de inscripción tendrán un indicador de servicio negativo, que aparece como una retención en el Centro estudiantil en MyCerritos, colocado en su cuenta de la matrícula. El efecto será colocar el acceso del estudiante a matricularse al final del ciclo de inscripción en el período conocido como Inscripción Abierta.
- D. Los estudiantes excluidos de la prioridad de inscripción deben recibir notificación de las opciones que tienen o qué se les aconseja ejercer. Vea también la sección de este procedimiento titulada "Apelaciones y Excepciones."

### **Criteria adicionales para la prioridad de inscripción de determinados estudiantes**

- A. Los estudiantes que de otra manera se especifican en el estatuto.
- B. Los estudiantes cuyo programa educativo requiere tiempo fuera del campus o bloques de tiempo asociados con las clases programadas para actividades tales como práctica, reuniones, asesoramiento y tiempo fuera de la escuela, lo que limita la elección de los períodos de clase.

### **GRUPOS DE ESTUDIANTES CON PRIORIDADES:**

**Nivel 1:** las citas de matrícula para los estudiantes en los grupos del Nivel 1 se programarán en todo el nivel con base en las unidades que han obtenido y el promedio de calificaciones acumuladas de conformidad con la normativa aplicable.

**Personal de las Fuerzas Armadas y veteranos recientes:** los estudiantes que son miembros o ex miembros de las Fuerzas Armadas de los Estados Unidos, que son residentes de California, por cualquier plazo académico, dentro de los cuatro años siguientes al cese del servicio activo. (Artículo 66025.8 del Código de Educación)

**CalWORKs:** estudiantes inscritos formalmente en el Programa CalWORKs. (Artículo 66025.92 del Código de Educación)

**EOPS:** estudiantes matriculados formalmente en los Programas y Servicios de Oportunidad Ampliada (Extended Opportunity Programs and Services, EOPS). (Artículo 66025.91 del Código de Educación)

**Jóvenes de crianza:** los estudiantes que se consideran formalmente como jóvenes de crianza actualmente o en el pasado, que son elegibles hasta los 24 años de edad inclusive. (Artículo 66025.9 del Código de Educación)

**SAS:** estudiantes que por sus discapacidades específicas están inscritos en servicios de accesibilidad estudiantil (Student Accessibility Services, SAS) (Artículo 66025.91 del Código de Educación)

**Nivel 2:** las citas de matrícula para los estudiantes en los grupos del Nivel 2 se programarán en todo el nivel con base en las unidades que han obtenido y el promedio de calificaciones acumuladas, de conformidad con la normativa aplicable.

**Estudiantes del Programa de Excelencia Académica (Scholars' Honors Students):** los estudiantes que han sido admitidos oficialmente en el Programa de Excelencia Académica cada semestre y en la actualidad se matriculan en los cursos o contratos del Programa de Excelencia Académica (Scholars' Honors Program).

**Estudiantes Atletas:** los estudiantes que se identifican como elegibles para participar en deportes intercolegiales.

**Estudiantes con Requisitos de Inscripción Obligatoria:** los estudiantes en cumplimiento de los requisitos del programa que deben mantener la condición de tiempo completo con los requisitos de tiempo de finalización para permanecer en los programas universitarios de Cerritos que están en programas financiados con donaciones con necesidades prioritarias de inscripción.

**Estudiantes matriculados:** estudiantes que, antes de su primer semestre de inscripción, completaron la admisión, orientación, evaluación y los componentes de asesoramiento de matriculación.

**Grupos de prueba, financiamiento u otros grupos especiales para el éxito estudiantil:** los estudiantes en grupos identificados por medidas mejoradas o aceleradas para el éxito estudiantil donde se emplean las pruebas, financiamiento y otras medidas especiales a corto plazo.

**Nivel 3:** las citas de matrícula para los estudiantes en los grupos del Nivel 3 se programarán en el orden en que los grupos aparecen en la lista y con base en las unidades que han obtenido y el promedio de calificaciones acumuladas, de conformidad con la normativa aplicable.

**Estudiantes de reingreso:** estudiantes que se inscribieron en el año académico anterior o en el curso de verano. Los estudiantes que no asistan al curso de verano no perderán la continuidad de la condición de estudiante de reingreso. La definición incluye a los estudiantes que no tienen créditos, quienes se matriculan en condición de estudiante con crédito.

**Estudiantes que se reinscriben:** los estudiantes que han completado al menos una unidad de crédito en Cerritos College y regresan después de un período de no más de un semestre sin contar el curso de verano.

**Nivel 4:** las citas de matrícula para los estudiantes en los grupos del Nivel 4 se programarán en el orden en que los grupos aparecen en la lista y con base en las unidades que han obtenido y el promedio de calificaciones acumuladas con esos grupos, de conformidad con la normativa aplicable.

**Inscripción doble:** estudiantes de penúltimo y último año de la escuela secundaria, según lo previsto y limitado en la Política del Consejo 5010 titulada Admisiones e inscripción simultánea y el Procedimiento Administrativo 5011 titulado Admisión e inscripción simultánea de la escuela secundaria y otros jóvenes estudiantes.

**Inscripción doble (grado K-10):** estudiantes de primaria y secundaria de la escuela secundaria hasta 10o grado, según lo previsto y limitado en la Política del Consejo 5010 titulada Admisiones e inscripción simultánea y el Procedimiento Administrativo 5011 titulado Admisión e inscripción simultánea de la escuela secundaria y otros jóvenes estudiantes.

### **LIMITACIONES DE INSCRIPCIÓN**

La inscripción en los cursos y programas se puede limitar a los estudiantes que cumplen los requisitos previos y los requisitos conjuntos establecidos. (Consulte la Política del Consejo y el Procedimiento Administrativo 4260 titulado Requisitos previos y requisitos conjuntos)

#### **Limitaciones de inscripción adicionales (incluyen, entre otros):**

- A. consideraciones de salud y seguridad;
- B. carga de trabajo de los profesores;
- C. disponibilidad de instructores calificados;
- D. limitaciones de financiamiento;
- E. planificación regional;
- F. requisitos legales;
- G. limitaciones de instalaciones, y

## **Prioridades cuando la inscripción debe limitarse**

- A. Por orden de llegada u otras técnicas de selección no evaluativas, siempre que se hayan cumplido todos los requisitos previos o los requisitos del curso.
- B. En el caso de las competencias intercolegiales, cursos de nivel avanzado o cursos de representación pública, se asignan los lugares disponibles a aquellos estudiantes que se consideren más calificados.
- C. Limitar la inscripción a cualquier procedimiento de selección que los estatutos autoricen expresamente.
- D. Limitar la inscripción en una o más secciones para los estudiantes inscritos en uno o más cursos, siempre que un porcentaje razonable de todas las secciones del curso no tengan tales restricciones.

## **Condiciones adicionales pueden ser aplicables al orden de inscripción**

Secciones de los cursos financiados por distribución que no es del estado como la educación por contrato para los empleados de una compañía, los programas financiados con donaciones, y ciertas secciones de paga (según lo permite la ley).

## **PÉRDIDA DE ELEGIBILIDAD PARA RECIBIR LA EXENCIÓN DE CUOTAS DE INSCRIPCIÓN DE LA PROMESA DE BECA DE COLEGIO DE LA CALIFORNIA (CALIFORNIA COLLEGE PROMISE GRANT, CCPG)**

Un estudiante ya no será elegible para recibir la Exención de cuotas de inscripción de la Promesa de Beca de Colegio de la California (California College Promise Grant, CCPG) si al estudiante se le pone en un período de prueba académico o de progreso, o en alguna combinación de estos, durante dos períodos académicos primarios consecutivos. La pérdida de elegibilidad entrará en vigencia en la primera oportunidad de inscripción después de que se haya tomado dicha determinación.

El distrito deberá notificar a los estudiantes sobre su asignación en el período de prueba académico o de progreso a más tardar treinta días después del final del período académico que provocó que al estudiante se le pusiera en un período de prueba. La notificación debe indicar claramente que dos períodos académicos primarios consecutivos en período de prueba ocasionarán la pérdida de la Exención de cuotas de inscripción de la CCPG hasta que el estudiante ya no esté en el período de prueba. La notificación también debe informar a los estudiantes acerca de los servicios de apoyo para estudiantes disponibles para ayudarlos a conservar la elegibilidad.

El distrito adoptará, exhibirá claramente y divulgará políticas que garanticen que los estudiantes estén informados acerca de los servicios de apoyo para estudiantes disponibles para ayudarlos a conservar y restablecer la elegibilidad para calificar para recibir la Exención de cuotas de inscripción de la CCPG. La divulgación incluye, entre otras, información proporcionada en los catálogos de la universidad y en los programas de clases.

El distrito establecerá procedimientos por escrito mediante los cuales un estudiante pueda apelar la pérdida de la Exención de cuotas de inscripción de la CCPG debido a circunstancias atenuantes, o cuando un estudiante con discapacidad solicite, pero no reciba, una adaptación razonable de manera oportuna. Las circunstancias atenuantes son casos verificados de accidentes, enfermedades u otras circunstancias que podrían incluir cambios documentados en la situación económica del estudiante, o bien, evidencia de que el estudiante no pudo obtener

servicios de apoyo esenciales para estudiantes. Las circunstancias atenuantes también incluyen la consideración especial de factores específicos relacionados con el estado del estudiante con respecto a la ayuda para Veteranos, el programa de California de Oportunidades de trabajo y responsabilidad hacia los niños (California Work Opportunity and Responsibility to Kids, CalWORKs), Programa de Oportunidad educativa (Educational Opportunity Program, EOPS) y servicios de accesibilidad estudiantil (Student Accessibility Services, SAS).

Un joven en régimen de acogida familiar no estará sujeto a la pérdida de la Exención de cuotas de inscripción de la CCPG debido a la asignación en un período de prueba académico o de progreso. Esta exclusión para los Jóvenes en régimen de acogida familiar es válida hasta la fecha que se especifica en la sección 66025.9(c) del Código de Educación.

## **APELACIONES Y EXENCIONES**

La intención de estos procedimientos es apoyar y promover el éxito del estudiante, incluyendo la finalización del programa, a través del acceso a los cursos necesarios. Las peticiones de apelación o para la exención de la aplicación de estos procedimientos están sujetas a consideración del Comité de Expedientes y Normas Académicas, o a quien este designe.

- A. Los estudiantes pueden apelar la pérdida de la prioridad de inscripción y/o la pérdida de la Exención de cuotas de inscripción de la CCPG debido a circunstancias atenuantes, ciertas condiciones especificadas en el Formulario de Inscripción de Prioridades y/o la Exención de cuotas de inscripción de la CCPG de Apelaciones, o cuando un estudiante con una discapacidad solicitada, pero que no recibió los ajustes razonables en el momento oportuno. Las circunstancias atenuantes verifican los casos de accidentes, enfermedades u otras circunstancias fuera del control del estudiante.
- B. Los estudiantes que han demostrado una mejora académica significativa restablecerán el estado la Exención de cuotas de inscripción de la CCPG y/o de prioridad de inscripción que perdieron. Es responsabilidad del estudiante verificar oportunamente los cambios del estado de las inscripciones de prioridad. El mejoramiento académico significativo se define como haber logrado por lo menos el promedio de calificaciones mínimo y las normas de progreso mínimas durante el semestre. El nivel académico mínimo es una calificación promedio mínima de 2.0, una vez que el estudiante haya intentado tomar 12 unidades semestrales; el progreso mínimo convencional es superior al 50% de todas las unidades en las que se inscribió que no reciban "W", "I", "NP", o "NC", una vez que el estudiante se haya matriculado en un total de al menos 12 unidades semestrales.
- C. Los estudiantes pueden solicitar el reintegro de la prioridad de inscripción y/o la Exención de cuotas de inscripción de la CCPG si se cometió un error institucional.

## **ADMISION**

### **¿Quién puede solicitar admisión?**

- Cualquier persona que sea graduada de secundaria o por lo menos de 18 años de edad.
- Estudiantes en su penúltimo año o con una forma aprobada de inscripción doble (Dual Enrollment).
- Estudiantes internacionales con visas válidas F-1 de no inmigrante.

## Como solicitar admisión

- Estudiantes que se matriculan por primera vez o que regresan después de una ausencia de uno o más semestres, deben completar una solicitud de admisión tan pronto como sea posible antes de el comienzo de inscripción. (Prueba de residencia podría ser necesaria). La solicitud de admisión se encuentra disponible en el sitio web de Cerritos College, [www.cerritos.edu](http://www.cerritos.edu), "Future Students/Apply", "Apply Online".
- Estudiantes internacionales con visa F-1 de estudiante.  
Estudiantes internacionales deben presentar una solicitud internacional de estudiante, reunir los requisitos de admisión específicos, y pagar una cuota de \$50 por el cobro de procesamiento.

## ORIENTACIÓN

**SRT/Colocación y Orientación-Consejería son requerimientos para todos los estudiantes nuevos o nuevos para el colegio.** Es recomendable que también los estudiantes que se han transferido de otros colegios completen la orientación.

### SRT/Colocación y Orientación-Consejería (AOC)

SRT/Colocación y Orientación-Consejería (AOC, por sus siglas en inglés) se necesita para los estudiantes de primer ingreso, nuevos en la universidad. Aparecerán dos retenciones en la cuenta MyCerritos de estos estudiantes: una retención por evaluación (ASM) y una retención por asesoría de orientación (ORI). *No se permitirá la inscripción en clases hasta que se haya cumplido con este requerimiento.* Los estudiantes a los que no se les solicite que completen los criterios establecidos quedan exentos automáticamente al momento de presentar la solicitud a la Universidad.

### Programa de Éxito Prematuro (Early Success Program, ESP)

El Colegio de Cerritos ofrece el Programa de Éxito Prematuro durante el otoño y el semestre de primavera. Éste programa está diseñado para motivar a los estudiantes a completar con anticipación la Evaluación y Orientación-Consejería. Si completan la Evaluación y Orientación-Consejería antes de el plazo indicado, los estudiantes nuevos para el colegio reciben una cita más temprana para inscribirse. Para obtener más información, visite la página web [www.cerritos.edu/esp](http://www.cerritos.edu/esp).

### Opciones de Orientaciones para Nuevos Estudiantes

#### En línea

Comience, pare, y vuelva a comenzar en cualquier momento! Vaya a [www.cerritos.edu](http://www.cerritos.edu), entre al sistema de *MyCerritos*, y elija *Orientation Plus*.

#### En el plantel

Hay orientaciones disponibles antes de el comienzo de cada semestre, incluyendo de día y de noche. Llame a Oficina de Consejería al (562) 467-5231, ó en línea en el sitio [www.cerritos.edu/aoc](http://www.cerritos.edu/aoc), para más información.

## ¿QUE ES "EL PROCESO DE COLOCACIÓN?"

El Colocación es obligatoria para los estudiantes de primer ingreso, nuevos en la universidad. "Colocación" significa el proceso de recopilar información sobre cada estudiante para facilitar su éxito. En Cerritos College el proceso incluyen, pero no se limitan a la recopilación de información relacionada con las técnicas de estudio del estudiante, dominio del inglés o aptitudes de computación. Los orientadores académicos revisarán el expediente académico de la escuela secundaria o universidad, evidencia del título A.A. u otro superior de una institución acreditada, habilidades de aprendizaje, rendimiento académico y uso de servicios especiales.

## ¿DEBO COMPLETAR EL PROCESO DE SRT/ COLOCACIÓN?

A partir de otoño de 2019, todos los estudiantes tendrán la oportunidad de colocarse en cursos de nivelación de inglés y matemáticas. Usando los expedientes de high school o la autocolocación dirigida, los estudiantes nuevos o regulares identificarán los cursos de inglés/inglés como segundo idioma (English as a Second Language, ESL) y matemáticas en los que pueden inscribirse.

Los estudiantes de primer ingreso, nuevos en el college, deben completar el proceso de colocación antes de la inscripción. Invitamos a los estudiantes regulares a quienes se les asignó un curso de matemáticas por debajo de matemáticas 80 o inglés 100 a completar este nuevo proceso de colocación.

Dependiendo de cuándo, dónde o si los estudiantes fueron a high school, completarán la herramienta de autoevaluación (Self-Report Tool, SRT) o la herramienta de colocación dirigida (Guided Placement Tool, GPT) que, en la mayoría de los casos, pondrá a los estudiantes directamente en los cursos de nivelación en las áreas de matemáticas e inglés o ESL. Para completar la SRT o GPT se necesita una identificación con fotografía y el número vigente de estudiante de Cerritos College.

¿Cómo completa la SRT o GPT? Visite el centro de evaluación en MP 206 o en línea en [www.cerritos.edu/assessment-center/](http://www.cerritos.edu/assessment-center/) para comenzar.

Recomendamos a los estudiantes con historia de educación especial a que busquen orientación para la asignación de más cursos con los consejeros en programas y servicios de accesibilidad estudiantil (Student Accessibility Services, SAS). Visite [www.cerritos.edu/dsps/](http://www.cerritos.edu/dsps/) para obtener más información.

## EXENCIÓN/EXCEPCIÓN DEL PROGRAMA DE ÉXITO Y APOYO PARA LOS ESTUDIANTES (STUDENT SUCCESS/ SUPPORT PROGRAM, SSSP)

Cerritos Community College ofrece Servicios de Éxito y Apoyo para los Estudiantes a todos los estudiantes nuevos antes de inscribirse en las clases. Estos servicios incluyen colocación, orientación y asesoramiento. Los estudiantes de primer ingreso, nuevos en la Universidad deben completar la evaluación y colocación-orientación (SRT/Placement and Orientation-Counseling) obligatoria antes de inscribirse. Los estudiantes que no deben completar con los criterios establecidos están exentos automáticamente al momento de presentar la solicitud de ingreso a la universidad. Los estudiantes que deseen otro tipo de exención deben presentar un formulario de Exención al Programa de Éxito y Apoyo para los Estudiantes (SSSP) y el formulario de exención a la Oficina de Admisiones y Expedientes. Los formularios de Exención y Excepción de SSSP están disponibles en las Oficinas de Admisiones y Expedientes, Evaluación y Asesoramiento. Si usted tiene necesidades especiales para completar el colocación, orientación o asesoramiento, comuníquese con la Oficina de Evaluación o Programas y Servicios para Estudiantes Discapacitados.

## EXENCIONES DE SRT/COLOCACIÓN

Los estudiantes que ya tienen un título de A.A. o superior de una universidad regional acreditada, no deben completar el proceso de colocación, pero deben verificar su título al presentar documentos oficiales ante la Oficina de Admisiones y Expedientes por lo menos 10 días hábiles antes de la fecha de su cita de inscripción. Debe adjuntar un formulario de Acreditación requerida con los documentos para cumplir con todos los requisitos.



# INFORMACIÓN EN ESPAÑOL

## EXENCIONES DE EVALUACIÓN/COLOCACIÓN PARA:

**Inglés:** es posible que los estudiantes que han completado cursos de inglés en otras universidades no tengan que completar la SRT de inglés. Presente pruebas (certificaciones oficiales o no oficiales) y el formulario de Acreditación requerida a un orientador o en Admisiones y expedientes antes de inscribirse.

**Matemáticas:** es posible que los estudiantes que han completado cursos de Matemáticas en otras universidades no tengan que completar la SRT de matemáticas. Presente pruebas (certificaciones oficiales o no oficiales) y el formulario de Acreditación requerida a un orientador o en Admisiones y expedientes antes de inscribirse. Se recomienda que estos cursos de Matemáticas se hayan completado en los últimos 10 años.

**Exámenes avanzados de ubicación:** los estudiantes que asisten a cursos de ubicación avanzados en sus escuelas secundarias y que obtengan promedios para aprobar los exámenes de AP pueden obtener créditos universitarios para dichos cursos cuando asistan a Cerritos College. Para obtener más detalles pregunte a un orientador.

**Química:** lea la sección de prerrequisitos y recomendaciones con cada listado de clases de química. Asegúrese de cumplir con todos los prerrequisitos antes de inscribirse en un curso.

*Tenga en cuenta: Las excepciones indicadas son opciones de evaluación para las acreditaciones o ubicación de cursos. Para cumplir con los niveles de destreza requeridos de Lectura, Matemáticas, Inglés para calificar para el título en Artes de nivel intermedio, revise su catálogo o pregunte a un orientador.*

## UBICACIÓN PARA INGLÉS COMO SEGUNDO IDIOMA

Es posible que los estudiantes que desean tomar cursos de inglés como segundo idioma (ESL) deban someterse a una prueba ACCUPLACER ESL. Al completar la SRT, los estudiantes recibirán una recomendación para tomar la prueba ACCUPLACER ESL cuando sea apropiado. Es posible que los estudiantes aún deban someterse a la prueba ACCUPLACER ESL si consideran que pueden beneficiarse de la instrucción de ESL. Si tiene preguntas relacionadas con el mejor curso de instrucción, reúnase con un orientador.

## POLÍTICA DE REPETICIÓN DE PRUEBAS

Los estudiantes que han completado la prueba ACCUPLACER y desean repetirla, ahora deben completar la Herramienta de auto evaluación (SRT). Los estudiantes que completaron sus estudios de escuela secundaria en los últimos 10 años recibirán recomendaciones de cursos con base en sus expedientes de la escuela secundaria de Estados Unidos. Con base en el promedio de notas acumuladas y ponderadas de la escuela secundaria de Estados Unidos y en otras preguntas académicas, los estudiantes se pueden ubicar directamente en los cursos de nivel de transferencia en las áreas de Inglés, Lectura, Matemáticas o ESL. Para completar la SRT computarizada necesita una identificación con fotografía y el número vigente de estudiante de Cerritos College. Los estudiantes que completaron sus estudios de la escuela secundaria hace más de 10 años antes de solicitar su ingreso a la universidad, que completaron GED o no terminaron la escuela secundaria o, si es estudiante internacional, deben comunicarse con la Oficina de Evaluaciones para obtener información relacionada con su situación específica.

## PROGRAMA DE EVALUACIONES

Hay copias del programa de evaluaciones disponibles en la página web de la Oficina de Evaluaciones de Cerritos College, [www.cerritos.edu/assessment-center](http://www.cerritos.edu/assessment-center); en la Oficina de Admisiones y expedientes, Servicios de orientación y carreras o llame al (562) 860-2451, ext. 2599 para ver

las fechas y los horarios. Las citas están disponibles durante el período de mayor demanda de pruebas entre julio y agosto. Para ver el programa vigente, consulte la página web ya que el programa está sujeto a cambios.

## ADAPTACIONES PARA ESTUDIANTES CON DISCAPACIDADES

Cualquier estudiante con una discapacidad comprobada puede gestionar adaptaciones para la evaluación. Debe tener una solicitud vigente registrada en Cerritos College para recibir las adaptaciones. Las solicitudes de adaptaciones se deben hacer con por lo menos 7 días hábiles de anticipación a servicios de accesibilidad estudiantil (Student Accessibility Services, SAS). Para obtener más información o programar una cita, llame al (562) 860-2451, ext. 2335; (562) 274-7164 (VP); o visite nuestro sitio web en [www.cerritos.edu/dsps](http://www.cerritos.edu/dsps). La administración alternativa puede incluir lectores, escritores o el uso de tecnología de asistencia.

## CONSEJERÍA

- Antes de inscribirse, todos los estudiantes nuevos en el college deben completar una orientación para estudiantes de primer ingreso para recibir ayuda del consejero en la elección de los cursos. Vea la sección "Orientation" (orientación) para obtener más información sobre la colocación y la orientación-asesoría. También recomendamos a los estudiantes de reingreso o transferidos que vayan con el consejero.
- Los consejeros tienen citas disponibles en persona o en línea, o en lista de espera/sin cita previa.
- Los estudiantes pueden enviar preguntas generales a un consejero en línea en [www.cerritos.edu/counseling](http://www.cerritos.edu/counseling).
- Planifique la orientación con citas programadas y en lista de espera/sin cita previa podría estar limitada durante los períodos de registro con mayor actividad.
- Una vez que empiece el semestre, recomendamos a los estudiantes nuevos, de reingreso y transferidos que hagan una cita para recibir orientación o que asistan a un taller de planificación educativa para hablar sobre sus objetivos educativos y hacer un plan educativo integral del estudiante (Comprehensive Student Educational Plan, C-SEP).
- Recomendamos a los estudiantes regulares que se reúnan con un consejero cada semestre para asegurarse de que su plan educativo refleje de manera precisa su objetivo educativo. Haga una cita o inscribese para el taller de planificación educativa en la recepción de Counseling (orientación) o llame al (562) 467-5231.
- A los estudiantes que están en período de prueba de su progreso o en período de prueba académica se les limitará la cantidad de unidades que pueden tomar cada semestre con base en su Promedio de Calificaciones (Grade Point Average, GPA) y cursos completados. También se arriesgan a perder su cita de prioridad de inscripción y, a partir de otoño del 2016, es posible que ya no sean elegibles para recibir el beneficio de California College Promise Grant Fee Waiver, CCPGFW, si continúan en período de prueba durante dos semestres consecutivos.

## SEGUIMIENTO

Consejería y profesores proporcionan una serie de servicios de seguimiento a los estudiantes. Estos servicios están diseñados para proporcionar información con respecto al progreso académico de los estudiantes. Se prestan servicios especiales a estudiantes que están en académico y/o progreso condicional, alumnus en cursos de habilidades básicas, y a los estudiantes que se encuentran indecisos sobre su meta educativa. Cuando es necesario los estudiantes son referidos a servicios fuera de esta institución.

# ENROLLMENT INSTRUCTIONS

## MYCERRITOS ENROLLMENT DATES

**June 8, 2020 - August 16, 2020**

**Monday - Saturday**  
**Sunday**

**2:00 am - midnight**  
**8:00 am - midnight**

\*Enrollment in late start classes continue through the day of the week prior to the start date.

## ENROLLMENT APPOINTMENTS

- All eligible continuing students have the opportunity to enroll for classes on or after their scheduled appointment date and time. Refer also to the "Student Success and Support Program" section on page 4 for information on enrollment priority, loss of priority, and appeal information.
- Appointment information can be reviewed in your "Student Center".
- To get to the **Student Center**, please log into the Cerritos College web page at [www.cerritos.edu](http://www.cerritos.edu).
- Select "**MyCerritos**" and log on by entering your User ID (your 7-digit student ID number). If your student ID number is 6 digits, please add a zero to the front of the numbers.
- Enter your password, which is your 6-digit date of birth (mmddyy) **unless** you have changed it. Please note that Cerritos College does not have access to passwords that have been changed.
- Once you have logged into **MyCerritos**, select **Student Center**.
- Your scheduled appointment date and time will appear in the yellow box under "**Enrollment Dates**" to the right of the page.

## WHO MAY ENROLL USING MYCERRITOS

All continuing students (students who attended Spring 2020), new, returning, and transfer students who have met Student Success and Support Program requirements.

*Exceptions:*

- First-time students who have an Assessment/SRT (ASM) or Orientation (ORI) hold.
- Students who have a Dismissal (DIS) hold.
- Students who have a "PRB" and/or "100+" hold due to second semester probation or more than 100 units.
- Students who have a Loss of CCPG Fee Waiver (LBW) hold.
- Students with enrollment holds (NSF checks, library and athletic obligations, administrative holds, etc.)

Information regarding probation and 100+ unit holds may be found on page 4 under "Priority Enrollment Criteria and Conditions".

## RECOMMENDATIONS BEFORE ENROLLMENT

### Academic Advisement:

Students who need advisement assistance are encouraged to see a counselor prior to their MyCerritos enrollment appointment date.

### Clear Holds:

All enrollment holds must be cleared prior to your enrollment date.

### CalWORKs, EOPS, Foster Youth, SAS, and Student Veterans:

Should first contact a counselor or specialist in their program for enrollment assistance.

## PLAN YOUR CLASS SCHEDULE

- **Check student data on enrollment appointment.** If there are corrections, please contact the Admissions and Records Office, in person, as soon as possible. Address, phone number, and email corrections can be made by using **MyCerritos, Student Center**.
- **Check "Holds" and "To Do List" prior to enrolling on MyCerritos, Student Center.**
- **List classes in priority order; 18 units maximum per semester.**
- **List alternative classes** in case your class choices are not available. Pick alternatives with the same time offerings.
- **Verify your placement scores and completion of prerequisites.** Identify required LABS and possible CLASS TIME CONFLICTS.
- **Students can make PROGRAM CHANGES (class adds and drops) by MyCerritos after initial enrollment.**

## WAIT LIST NOTES

- **Cerritos College uses an "auto-enroll" process from wait list to roster. You are responsible for all drops.** If you do not want your wait-listed classes, please drop to avoid a substandard grade and forfeiture of enrollment fees. For more information on wait lists, see "Wait List" on page 17.
- **Prerequisites ARE CHECKED WHEN YOU ARE PLACED ON A WAIT LIST.** They are also checked at enrollment. YOU MAY LOSE A SEAT if prerequisites are not met when the instructor adds you to a class, or "auto-enroll" is activated. "Auto-enroll" will automatically enroll students from the wait list to the official roster when space becomes available.
- **If you are enrolled in a class AND are on a wait list for the same course (i.e., enrolled in SOC 101 and #1 on the wait list for SOC 101 at another time), you will lose a seat when "auto-enroll" tries to move you from the wait list to the official roster due to "Multiple Enrollment".**

## TO ENROLL

Verify your appointment date and time. If you log on to **MyCerritos before** your appointment date and time, the system will not allow you to enroll. However, you may log on anytime on or after your scheduled appointment date and time during published enrollment hours.

- Go to **MyCerritos** (<http://my.cerritos.edu>) or the Cerritos College home page and select **MyCerritos**.
- Enter your User ID (7-digit student ID number) and Password (6-digit date of birth).
- Select "**Student Center**".
- Select "**Enroll**".
- Verify Term (Fall 2020).
- Enter Class Number and select "**Next**".
- Verify class information and availability, and select "**Next**". If your class is closed you may wish to be added to a wait list, if available. Check the "**Wait List**" box and select "**Next**".
- Your class is now in your "**Shopping Cart**". You may enter another class number or, if done, select "**Proceed to Step 2 of 3**".
- Confirm your class(es) and select "**Finish Enrolling**".
- Verify your status as "**Success**".
- To pay for your class(es), select "**Make a Payment**" and follow the directions for credit card payments.

**PLEASE NOTE:** Students wishing to take a short-term class that is a prerequisite to the subsequent short-term class may enroll **IN PERSON** for class.

*Example:*

1<sup>st</sup> 9 weeks

English 72

2<sup>nd</sup> 9 weeks

English 100

The student may enroll in English 72 on their scheduled appointment date via MyCerritos AND THEN enroll in English 100, on or after their scheduled appointment date, by contacting the Admissions and Records Office at [admissions-info@cerritos.edu](mailto:admissions-info@cerritos.edu).

## PAYING YOUR FEES

**IMPORTANT:** Students are required to pay all fees at the time of enrollment. Payment plans are not available. Each enrollment in a class, or add to a wait list for a class, results in a fee amount due. Students adding their names to wait lists will be charged the applicable enrollment fees, tuition, and applicable lab/materials fees. The amounts due will appear on the student account. **PAY CLOSE ATTENTION TO ALL DEBTS LISTED FOR EACH TRANSACTION.** The California College Promise Grant (CCPG) waives students' course enrollment fees; **however, all other fees, including but not limited to the Student Health fee, Student Activity fee, and applicable lab/materials fees, are due and payable at the time of enrollment.** (See FEES on page 19 for waiver information.)

Enrollment Period	Payment Schedule	Failure to Pay on Time
June 8, 2020 – August 16, 2020	<b>Online:</b> Monday – Saturday, 2 am – midnight Sunday, 8 am – midnight	May result in a drop from classes and/or wait lists
Sunday, August 16, 2020	<b>IOnline:</b> Monday – Thursday, 8 am – 6:30 pm Friday, 8 am – 1:30 pm	May result in a drop from classes and/or wait lists
August 17, 2020 – Instructor Add Period	Midnight of the following day	HOLD on all student accounts and records

### ON THE WEB VIA MYCERRITOS ([HTTP://MY.CERRITOS.EDU](http://my.cerritos.edu)):

- After logging in, select “Student Center” on the MyCerritos home page.
- Under "Finances", select “Make a Payment”.
- Fees must be paid by credit card (MasterCard, VISA, Discover or American Express).

### BY MAIL:

- MyCerritos will indicate your total fees and the date your payment is due.
- Enclose a money order or cashier’s check, or complete the credit card information on your registration payment coupon. **Cerritos College does not accept personal checks.** Please make your payment in the exact amount due and print your Student I.D. number in the “memo” portion of your money order or cashier’s check.
- Send your payment to: Admissions and Records, Cerritos College, 11110 Alondra Boulevard, Norwalk, CA 90650

*If you require further assistance, contact the Admissions and Records Office at (562) 860-2451, extension 2211, 8 am–6 pm, Monday through Thursday; 8 am–4 pm, Friday.*

# BECOME A LEADER – JOIN STUDENT GOVERNMENT

**WWW.CERRITOS.EDU/ACTIVITIES**



## WAIT LIST

As you enroll in classes, you may find that some are “closed.” This means that these classes have reached maximum enrollment. In this event you may choose to add your name to the wait list. The number of additions to wait lists is limited to 10 units. Please follow the instructions in **MyCerritos, Student Center**.

Cerritos College has implemented a “paid” wait list. What this means is that once you have added your name to the wait list, you must pay all applicable fees for that class. Additionally, “auto-enroll” will be in operation. Auto-enroll will automatically enroll students from the wait list to the official roster when space becomes available. Auto-enroll from a wait list will not occur if:

1. Student has a hold (service indicator) on their account. Please check in **MyCerritos, Student Center**, under **Holds and To Do List**.
2. The class prerequisite has not been met.
3. Illegal course repetition has occurred (See the Admissions and Records web page for Academic Records and Standards petition).
4. There is a class time conflict. Students may not be enrolled in two classes that meet at the same time.
5. If you are enrolled in a class AND are on a wait list for the same course (i.e., enrolled in SOC 101 and #1 on the wait list for SOC 101 at another time) you will lose a seat when “auto-enroll” tries to move you from the wait list to the official roster due to “Multiple Enrollment”.

Auto-enrollment will continue through the Friday before classes begin. View your enrollment status on **MyCerritos** (<http://my.cerritos.edu>). **Failure to attend class IS NOT an automatic drop or refund. If you do not want your wait-listed classes, please drop to avoid a substandard grade and forfeiture of enrollment fees.**

**Prompt attendance on the first day is recommended for all wait-listed students. Failure to attend will jeopardize your enrollment status.**



# READING THE CLASS SCHEDULE

*Must satisfy requirements PRIOR to taking the course*

*Course number*

*Course name*

**ENGL 100**      **4.0 UNITS**      **FRESHMAN COMPOSITION**

Transferable to UC, CSU (CAN ENGL 2)  
 Prerequisite: Satisfactory completion of the English Placement Process or ENGL 52 or equivalent with a grade of Pass or "C" or higher.

20372	11:00- 1:00PM	MW	STAFF	CB101
20375	2:00- 4:00PM	MW	Clemens,S	CB102
20376	3:00- 5:00PM	TTh	Ernest,R (HYBRID)	LC213
<b>20880</b>	<b>5:00- 7:00PM</b>	<b>MW</b>	O'Neil,S	LC134
21681	4.0 HRS ARR	(OL)	Swanson,J	ONLINE

Mandatory Orientation: 7:00 - 9:00 am, Saturday - January 14 in PS20.

22149	7:00- 9:00AM	TTh	Mueller,B	LC134
22082	7:00- 9:40PM	TTh	STAFF	CB103

Class#22082 meets 01/30/2012-05/18/2012

23244	8:00-12:00PM	MW	Conley,A	CB106
-------	--------------	----	----------	-------

Class#23244 meets 01/09/2012-03/09/2012

23065	1:00- 5:00PM	TTh	STAFF	CB102
-------	--------------	-----	-------	-------

Class#23065 meets 03/12/2012-05/18/2012

*Time class meets. Evening classes are designated in bold print*

*Class meets online*

*Class number needed for enrollment*

*Dates class meets*

*Classes meet both on campus and online- See definition below*

*Online course- See definition below*

*Instructor name*

*Building & room number*

*Days the class meets*

*Specific instructor not yet designated*

**Online** – Most work and communications occur online. Access to email and the internet is required.

**Hybrid** – Hybrid courses meet both on campus and online. See your instructor’s website for class meetings.



# FEES/REFUND INFORMATION AND PROCEDURES

## FEES

1. **\*Enrollment Fee:** \$46 per unit.
2. **Non-Resident Tuition:** Students who are non-residents of California or International Students, with or without F-1 visas, will be assessed \$310 per unit (\$290 per unit non-resident tuition and a \$20 per unit capital outlay fee) in addition to the \$46 per unit enrollment fee above.
3. **Student Activity Fee:** \$10 per semester; \$4 for summer session. This fee is automatically charged and is due and payable at enrollment, but may be waived subsequently by the student. Fee purpose and waiver information is available online at both the Admissions and Records' and the Office of Student Affairs' websites.
4. **Student Representation Fee:** \$2 per semester; \$2 for summer session. Fee purpose is available on the Student Activities website. This fee may be waived in advance by completing the form on the Admissions & Records website.
5. **Student Health Fee:** \$19 per semester; \$16 for summer session. Students who rely on prayer for healing and can supply the college with documentation from their spiritual leader are exempt.
6. **Parking:** On-campus student parking for vehicles will be free. There will be no cost for student parking during the Fall semester 2020, between the hours of 6 am and 10 pm. Students parking in white student stalls will not require a parking permit. All other parking violations will be strictly enforced (i.e. Student's parking in staff stalls, handicapped and fire zone violations).
7. **Lab/Materials Fees:** As listed with courses in this class schedule. Please note that failure to pay these fees may result in withdrawal from courses for lack of payment.

Students are required to pay all fees at the time of enrollment. Students adding their names to wait lists will be charged the applicable enrollment fees, tuition, and applicable lab/materials fees. Students who do not pay fees and drop classes after the refund date are still responsible for all fees. **California College Promise Grant Fee Waiver (CCPGFW) waives students' course enrollment fees; however, all other fees, including but not limited to the Student Health fee, Student Activity fee, and applicable lab/materials fees, are due and payable at the time of enrollment.** Payments for the parking, student activity, and student health fees may be subject to additional considerations.

The Student Activities Fee and Student Representation Fee are subject to student waiver. Information is available from the Office of Student Affairs located in the Student Activities Office. The Waiver Request forms are available online at the Admissions and Records web page. Revenue from the collection of these fees may be used by ASCC to support or oppose political measures. The student health fee may be waived with documentation from the student's spiritual leader that the student relies on prayer for healing.

\*Subject to legislative change.

## RESIDENT REQUIREMENTS

To be considered a California resident for purposes of admission to Cerritos College, a student is required to have resided in the state of California for at least one year and one day prior to the start of the semester for which the student is enrolling and present intent for one year and one day prior to the start of the semester for which the student is enrolling.

## REFUND POLICIES AND PROCEDURES

It is the student's responsibility to apply for a refund. A student is eligible for a refund after classes have been officially dropped. Classes must be dropped

by the appropriate deadline for the session in order to be eligible for a refund. Stated deadlines are not adjusted due to late enrollment. Session dates and deadlines available for viewing online.

A student is eligible for a refund if: a) classes are dropped by the required deadline; b) the program change is the result of action taken by the college to cancel or reschedule a class; c) the student is dropped for failure to meet a prerequisite(s) or corequisite(s); and/or, d) the student is active or reserve U.S. Military personnel who withdraws due to military orders.

Eligible students may file a petition with the district requesting refund of their enrollment fee(s). A refund will not be processed if academic credit has been awarded for the class. Refunds are not automatically processed.

To request a refund, a student must contact the Admissions and Records Office and submit a Refund Request Form. The Refund Request Form is also available online and can be emailed to the Admissions and Records Office. Approved refunds will be emailed in approximately four to six weeks. Be sure your current mailing address is on file with the college.

A check is the only form of payment that Cerritos College uses to issue refunds. If a payment is made by credit card for any registration transaction, and you later drop any or all of your classes within the required refund period, we will **NOT** credit your credit card account. All refund checks are made payable to the student.

*Refunds are made pursuant to Title 5, Section 58501 or 58501.1.*

## CREDITS/REFUNDS

### Credits

**Enrollment Fee, Non-Resident Tuition, and Capital Outlay Fee** will be credited if the official drop has occurred within the appropriate deadline\* for session or semester. This is in accordance with the Refund of Enrollment Fee Regulation, Title 5, 58508.

**Student Health, Student Activity<sup>1</sup>, Student Representation, and Parking Fees<sup>2</sup>** will be credited only if all classes within the semester have been officially dropped within the appropriate deadline\* for the semester.

\* *Deadlines for fee credit are defined as the first two weeks of full semester length classes, or 10% of class meetings for shorter than semester-length classes.*

<sup>1</sup> *Student Activity sticker for the semester must be surrendered at the time of refund request. No refund will be given if sticker is marked or used.*

<sup>2</sup> *Parking Permit for the semester must be surrendered at the time of refund request.*

### Refunds

A Refund Request Form must be completed to receive credit funds on the account. The Refund Request Form is available online on the Admissions web page under "FORMS", or in the Admissions and Records Office.

**Time limit on requesting a refund:** A **one-year limitation** exists on the credit. Students must apply for the refund between the beginning of the semester in which the credit was issued and the last day of the semester one year later.

**MYCERRITOS ACCEPTS PAYMENT BY MASTERCARD, VISA, DISCOVER OR AMERICAN EXPRESS CREDIT CARD.  
This method of payment is encouraged for immediate confirmation of your enrollment.**

# ACADEMIC INFORMATION

## REPETITION OF COURSES

At Cerritos College, previous course enrollment is reviewed electronically for prior enrollment attempts. All courses have repetition limitations. Cerritos College offers some courses that have designated repeatability. Please review the catalog for maximum repeat units available.

Students may repeat a course in which a substandard grade (D, F, NP, FW) or “W” in any combination has been received one time. Students receiving any combination of substandard grades may petition the Academic Records and Standards Committee for an exception to the two attempts rule. All petitions are subject to approval or denial. Upon completion of a repeated course, the most recent grade earned will be computed in the cumulative grade point average and the student’s academic record so annotated.

When a student repeats a class to alleviate substandard academic work, the previous grade and credit shall be disregarded in the computation of grade point averages, but shall not be deleted from the student’s permanent record. Courses that are repeated shall be recorded on the student’s permanent academic record using an appropriate annotation. Annotating the permanent academic record shall be done in a manner so that all work remains legible, insuring a true and complete academic history.

Students may use an equivalent course from an accredited college or university to replace a Cerritos College course in which a substandard grade was recorded, if earned subsequent to the substandard grade at Cerritos College. The student must petition the Academic Records and Standards Committee to record the change. The College may honor the prior course repetition actions of other accredited colleges and universities in determining acceptance of credits, subject to student petition to, and approval by, the Academic Records and Standards Committee.

### Examples of Exceptions for Consideration of Course Repetition Limitations

An Academic Records and Standards petition must be filed for official consideration of course repetition. All petitions are subject to approval or denial. Contact the Admissions and Records Office for specific directions.

1. Student received an “MW” (Military Withdrawal), or student received an “EW” (Extenuating Withdrawal).
2. Student’s previous grades are a result of documented extenuating circumstances beyond his/her control.
3. Cooperative work experience courses, subject to stated maximums, as provided in the College Administrative Procedures.
4. Certain activity or skill building courses, subject to stated maximums, as provided in College Administrative Procedures.
5. Certain classes for students with disabilities, subject to stated qualifications, as provided in College Administrative Procedures.
6. Repetition necessary for legally mandated training. Such courses may be repeated any number of times, regardless of whether or not substandard work was previously recorded, and the grade received each time shall be included for purposes of calculating the student’s grade point average.
7. After a significant lapse of time, a student may repeat a course in which a grade of “C” or better was received if the course is required by the district as a properly established recency prerequisite or another institution of higher education, to which the student is seeking to transfer, requires the student to have taken the course more recently than the student’s last enrollment (Title 5, Sections 55040(b)(3), 55053).

## PASS/NO PASS CLASSES

Classes offered on a non-optional pass/no pass basis only will be indicated on a student’s permanent record as a “P” grade (with unit credit) or “NP” grade (no units earned). This will not affect the student’s grade point average. Optional pass/no pass courses are designed to encourage students to explore courses in areas they feel they may have an interest. See page 23 for guidelines and a list of approved courses in each department.

## OPEN ENTRY/OPEN EXIT CLASSES

All students should meet with the instructor as soon as possible after the start of the session to inquire about enrollment (unless otherwise noted). A student may enter these classes at any time during the session prior to the specific cut-off date for the individual classes. The courses may be completed within the session in whatever time is necessary for the student to finish the course requirements.

## DIRECTED STUDIES

Any student interested in pursuing independent projects on an individual basis for one or two units should contact a faculty member to determine if he/she is available to sponsor a directed studies project. Students may enroll in these classes only through the second week and with the authorization to enroll in Directed Studies Form, which must be signed by both the instructional dean and the faculty member conducting the Directed Studies.

## WORK EXPERIENCE

Students may register for Cooperative Work Experience only through the second week of classes. Only a reduction of hours may be made after the first week.

## PREREQUISITES, COREQUISITES, RECOMMENDATIONS AND PREREQUISITE CHALLENGE PROCEDURE

Please see “Prerequisites” in the Cerritos College Catalog.

## DEFINITION OF A CLASS HOUR

A “class hour” is the basic unit of scheduled attendance and/or examination and is defined as a period not less than 50 minutes. A “clock hour” is a 60-minute time frame which is composed of one 50-minute class hour and a 10-minute segment referred to as a “passing period” or “break”. Classes scheduled for more than an hour follow formulas to stay within this definition. For example, a class scheduled from 8:00 to 8:50 has already incorporated the passing period and students must be in attendance for the full 50 minutes. Cerritos College has scheduled classes to account for the passing period and there is no need to leave 10 minutes early. Classes that meet for multiple hours may assign a 10-minute break between hours, but not in the last hour of attendance. Cerritos College follows these time patterns.

## WITHDRAWALS [TITLE V, SECTION 58004 (C) (3)]

Pursuant to Title 5, section 58004 and Cerritos College Board Policy, it is the student’s responsibility to participate fully in class (es), once enrollment is complete. However, should it become necessary to withdraw from class, it is the student’s responsibility to drop in person in the Admissions and Records Office or through MyCerritos.

# ACADEMIC INFORMATION

## THE ULTIMATE RESPONSIBILITY OF WITHDRAWAL FALLS TO THE STUDENT.

### How to officially withdraw after enrollment ends:

Complete an Add/Drop card (available in the Admissions and Records Office) or for a faster response, use MyCerritos (<http://my.cerritos.edu>). Retain an updated printout for your records.

**ALL WITHDRAWALS MUST BE COMPLETED BY THE LISTED DEADLINES. FAILURE TO OFFICIALLY WITHDRAW FROM CLASS(ES) MAY RESULT IN AN “F/FW” GRADE FOR EACH CLASS. See the “Session Dates and Deadlines” now available online at: <https://www.cerritos.edu/admissions-and-records/add-drop-dates>.**

**WITHDRAWALS RESULTING IN PROGRESS PROBATION AND/OR GRADES RESULTING IN ACADEMIC PROBATION FOR TWO CONSECUTIVE TERMS CAUSE LOSS OF ENROLLMENT PRIORITY, WITH CERTAIN EXCEPTIONS, AND ARE SUBJECT TO APPEAL.**

### PROBATION

#### A. Academic Probation

Students who have attempted at least twelve (12) semester units as shown by the official academic record shall be placed on academic probation if the students have earned a grade point average below 2.0 in all units undertaken at Cerritos College.

#### B. Progress Probation

Students who have enrolled in a total of at least twelve (12) semester units as shown by the official academic record shall be placed on progress probation when the percentage of all units at Cerritos College which the students have attempted and for which entries of “W,” “I,” and “NP” are recorded reaches or exceeds 50 percent.

Probation is entered on the student’s permanent records and transcripts of record. Students placed on academic or progress probation will be notified by email at the email address listed on the official college record.

### Probation Clearance:

#### A. Academic Probation Clearance

Students may clear academic probation by earning sufficient grade points to raise the cumulative grade point average to 2.0 or higher in the next semester of attendance. Probation status is not cleared by one semester of 2.0 GPA if it does not raise the cumulative GPA to 2.0 or higher.

#### B. Progress Probation Clearance

Students may clear progress probation by decreasing the percentage of “W,” “I,” or “NP” entries to less than 50 percent of all units in which the students have attempted.

### Appeals:

Appeals of the loss of enrollment priority must be submitted on the Enrollment Priority Appeals Petition available on the Admissions and Records website. Automatic clearance is provided to students who achieve Significant Academic Improvement as defined in regulations.

### STANDARDS FOR DISMISSAL

#### A. Academic Dismissal

Students are subject to academic dismissal when their GPA is less than 2.0 in 12 units or more for two consecutive semesters on academic probation. Students subject to academic dismissal shall be placed on continued probation when their latest semester’s GPA is 2.0 or higher.

#### B. Progress Dismissal

Students who have been placed on progress probation shall be

subject to dismissal if the percentage of units in which the students have been enrolled and for which entries of “W,” “I,” or “NP” are recorded in at least two (2) consecutive semesters reaches or exceeds 50 percent. Students subject to progress dismissal shall be placed on continued probation when no “W,” “I,” or “NP” entries are recorded for their latest semester.

Students are notified they have been placed on probation shortly after the beginning of the subsequent semester. Dismissal notices are issued before the start of the fall semester. Dismissed students may attend summer session to improve academic deficiencies.

### REINSTATEMENT AFTER DISMISSAL

#### A. Academic Reinstatement

Students may re-enter the semester following academic dismissal through successful petition to the Academic Records and Standards Committee. However, such students will remain on probation until the accumulated GPA is 2.0 or higher.

#### B. Progress Reinstatement

Students may re-enter the semester following progress dismissal through successful petition to the Academic Records and Standards Committee. However, such students will remain on probation until the percentage of “W,” “I,” or “NP” entries is less than 50 percent of all units in which the students have enrolled.

Petitions must be filed prior to the deadline indicated on the readmission petition.

### ADD/DROP PROCEDURES

If you wish to change your class schedule, please follow the steps below:

- Classes may be added via **MyCerritos, Student Center** (<http://my.cerritos.edu>).

To add a closed class, go to class on the first day and time that it meets; be on time. Respectfully request of the instructor(s) to be added to the class(es). If the instructor approves, an electronic enrollment will be submitted on your behalf to the Admissions and Records Office. Note that prerequisites, holds/service indicators (SI), conflicts, and illegal course repetition will be checked. Refer to the Fee Payment Schedule on page 16 for payment deadlines. Check your student account via **MyCerritos, Student Center** (<http://my.cerritos.edu>) or in the **Admissions and Records Office**. All enrollments must be completed by the listed add deadlines.

- Classes may be dropped via **MyCerritos, Student Center** (<http://my.cerritos.edu>). Be mindful of deadline dates for refunds and posting of “W’s” to transcripts.

### LEVEL/SECTION CHANGES

**Level/section changes must be processed by the Admissions and Records office.** Program changes which involve level changes in skill and performance classes may be made by the add deadline. Students may also make level changes in Work Experience classes by the add deadline, but only a reduction of hours may be made after the add deadline.

Section changes may not be made between terms or semesters. A student may not drop a first 6/8-week course and then enroll in a second 6/8-week course by executing a section change. The student is required to officially drop the first 6/8-week class and then pay the appropriate fees to be enrolled in the second 6/8-week class. The money will not transfer from one term to another if the drop is processed outside of the refund date.



# ACADEMIC INFORMATION

## WHAT CERRITOS COLLEGE OFFERS

- Freshman and sophomore level course work transferable to four-year colleges and universities.
- Vocational/Technical courses designed to prepare for immediate employment.
- General education course work designed for academic, cultural, and educational enrichment.

## DEADLINES

Throughout the enrollment process (including class petitioning), certain deadlines are necessary in order to comply with state attendance laws and must be followed by all students. Failure to comply with these guidelines may mean that the student will not be enrolled and will not receive credit for, or be allowed to, attend classes. Stated deadlines are not adjusted due to late enrollment.

## RETURNED CHECK POLICY

Personal checks are not accepted for payment of tuition, fees, and other costs. If a check is accepted for another purpose, a \$25 fee will be charged on all returned and stop-payment checks. All fees are subject to change without notice in accordance with action taken by the Board of Trustees. Under state law, including California Civil Code 1719, any person who writes a check which is dishonored for lack of funds is civilly liable, and under the law is liable for at least \$100 or three times the amount of the check, plus additional costs.

## FAILURE TO PAY FINANCIAL OBLIGATIONS

Failure to pay a financial obligation will result in an administrative withholding of grades, transcripts, diplomas or enrollment privileges, or any combination thereof. The item or items being withheld shall be released when the financial obligation has been met (California Code of Regulations, Title 5, Section 59410).

## AUDITING OF COURSES

Auditing courses is permitted at Cerritos College. An auditor is a student who attends a course or courses for no credit or notation on an official transcript. Auditing may be available, pending signed permission, for any student who wishes to attend a course for information, review purposes, or skill building. Students wishing to audit should be aware that audited courses will NOT appear on the official transcript.

1. Students may not audit a course unless he/she has **exhausted all possibilities to take the course for credit**.
2. If criteria is met, permission to audit a course is granted at the discretion of the instructor. Signature of both the instructor and division dean are required.
3. With the instructor's and division dean's signed permission, a student may submit the audit form to the Admissions and Records Office anytime during the semester after the first class meeting.
4. An auditor may be allowed to elect credit in lieu of audit **prior** to the end of the **5th week** of school for a semester length course or **prior** to 30% of a course for a short-term course, **with the instructor's written permission**. No refund of audit fees will be available and all credit fees must be paid in full at the time of credit election.
5. A credit student may be allowed to elect audit status in lieu of credit **prior** to end of the **5th week** of school for a semester length course or **prior** to 30% of a course for a short-term course, **with the instructor's written permission**. No refund of credit fees will be available after the refund deadline and all audit fees must be paid in full at the time of audit election.
6. Credit students have priority over auditing students. If a course closes after an auditor has been admitted, the auditor may be asked to withdraw to make room for a credit student. Instructor discretion is strongly recommended.
7. The fee to audit a class is **\$15** per unit (in addition to the student fees). Students enrolled in 10 or more units can audit 3 units free (may be 3 one-unit classes). The **\$15** per unit audit fee will automatically be charged if the student drops below 10 units.

For additional information regarding auditing, students may make inquiries at the Counseling Office, Office of Academic Affairs, division office, or the Admissions and Records Office. Audit forms may be obtained on the Admissions and Records Office website.

## CREDIT BY EXAM CLASSES

Occasionally a student may feel that he/she can earn credit for a certain course by taking a special examination. The student may have gained proficiency through work experience, travel, or independent study. In these cases, a student may petition to receive unit credit by taking an exam prepared by the department. For more information, contact your counselor.

Credit by Examination will not be offered this semester by the Modern Languages Department.

The following courses have been designated by the divisions as those which may be taken for credit by examination:

### **BUSINESS, HUMANITIES, & SOCIAL SCIENCES**

Accounting 100  
Administration of Justice (all courses except for AJ 71, 91, 107, 173, 220)  
Business Administration 106, 107, 114, 115, 118, 120, 132, 156  
Business Communications Office Technology 131

### **FINE ARTS & COMMUNICATIONS**

Art 120  
Music 100, 101, 102, 103, 104, 104B, 105, 106, 110, 112, 120  
Photography 160  
Theatre 101, 102, 103, 110, 150, 151

### **HEALTH OCCUPATIONS**

Child Development/Early Childhood 161  
Culinary Arts 101  
Health Occupations 152  
Medical Assisting 63, 161  
Nursing (all courses)  
Pharmacy Technician 50, 83, 85

### **SCIENCE, ENGINEERING, & MATH**

Astronomy 102, 103  
Mathematics 75, 80  
Physics 100

### **TECHNOLOGY**

Autobody 51, 61, 181  
Automotive 54, 55, 100, 101, 107, 109, 110, 120, 130, 140, 150, 160, 170, 180, 280  
Engineering Design Technology 103, 104, 105, 116, 117, 131, 133, 134, 138, 237, 257, 259, 260, 261, 262, 263  
Engineering Technology 101, 102, 103, 137, 139  
Machine Tool Technology 51, 59, 68, 71, 72, 180, 278  
New Product Development 100, 101, 102, 103, 104, 105, 106  
Plastics Manufacturing Technology 51, 53, 61, 67, 70, 72, 76, 100, 221



# PASS/NO PASS CLASSES

The option to enroll in a pass/no pass class is designed to encourage students to explore courses in areas they may feel they have an interest. Only these courses listed specifically for pass/no pass may be taken on this basis. Units thus earned may be counted toward the A.A. degree, but grade points are not assigned to pass/no pass grading symbols.

Courses approved for pass/no pass will be indicated on the student's permanent record as "P" with units earned and no grade points; or "NP" with no units earned and no grade points. Units attempted for which "NP" is recorded shall be considered in probation and dismissal procedures. The student is required to take all tests, complete all assignments, and shall be subject to all withdrawal and attendance regulations. Standards of evaluation are identical for all students. Please refer to the college catalog for additional information.

## **Non-Optional Pass/No Pass Classes**

These classes are offered on a pass/no pass basis only and are graded entirely on a pass/no pass basis.

### **APPRENTICESHIP**

Fire Sprinklers 72.01, 72.02, 72.03, 72.04, 72.05, 72.06, 72.07, 72.08, 72.09, 72.10, 72.11, 72.12, 72.13, 72.14, 72.15, 72.16, 72.17, 72.18, 72.19, 72.20, 72.21, 72.22, 72.23, 72.24, 72.25

### **BUSINESS, HUMANITIES, & SOCIAL SCIENCES**

Law 1T

**COUNSELING** 10, 100, 101A, 101B, 101C

### **DISABLED STUDENT PROGRAMS & SERVICES**

Access Learning 90, 91, 92

### **HEALTH OCCUPATIONS**

Dental Assisting 1

Health Occupations 7

Nursing 5, 25, 26, 48T, 57LA, 57LB, 57LC, 57LD, 251

Physical Therapist Assistant 126, 236, 246

### **KINESIOLOGY**

Dance 50, 108C

### **LIBERAL ARTS**

English 5L

English as a Second Language 36

Reading 6, 41

**LIBRARY** 50, 100, 101

### **SCIENCE, ENGINEERING, & MATH**

Biology 95

Chemistry 95A, 95B, 95C, 95D, 95E, 95F

Math 5

Physics 95

### **TECHNOLOGY**

Woodworking Manufacturing Technology 291

### **Optional Pass/No-Pass Classes: 15-unit limit**

The student shall petition for an optional pass/no pass course through the Admissions and Records Office. The request for such a class must be completed no later than the end of the first 30% of the term. A student may be allowed to elect a letter grade in lieu of the pass/no pass option prior to completion of 30% of the course. See college catalog for addi-

tional information.

### **BUSINESS, HUMANITIES, & SOCIAL SCIENCES**

(all business courses, except Business Administration 109, 116, 124, 125, 126, 208, 233; Law 65, 104, 105, 115, 150, 160, 171, 172, 290; Real Estate 98, 99, 101, 120, 125, 130, 151, 174A; or those listed under Non-Optional Pass/No Pass classes)

Administration of Justice 101, 102, 103, 113

Anthropology 170, 203

Economics 101, 204

History 120, 230, 245, 250, 255, 260, 265

Interdisciplinary Studies 100

Philosophy 100, 102, 103, 104, 106, 200, 298, 299

Political Science 90, 110, 210, 230

Sociology 110, 205, 220

Women's and Gender Studies 115, 140

**COUNSELING** 200, 210, 220, 298, 299

### **FINE ARTS & COMMUNICATIONS**

Art 106, 110, 114, 116, 118, 120, 133A, 150, 155, 156L, 171, 182A, 191A, 191B, 193, 194A

Film 101, 103, 104, 159, 160, 293

Journalism 100, 101, 106, 107, 111, 119

Music 100, 101, 102, 103, 104, 104B, 112, 139, 143, 152, 153, 171, 244

Photography 100, 171

Theatre Arts 101, 107, 115, 120, 123, 123A, 126, 144, 150, 151, 171, 208, 216, 221, 221A, 222

### **HEALTH OCCUPATIONS**

Health Occupations 150

Nursing 80

### **KINESIOLOGY**

Athletics 202L, 240, 241, 242

Dance 100, 101, 102, 105, 106A, 106B, 107, 108A, 108B, 109, 110, 112, 120, 121, 122, 123, 124, 125, 126, 130A, 130B, 131, 132, 133, 134, 135, 136, 140, 141, 142, 143, 144, 150, 151

Health Education 100, 101, 110, 200, 201, 202

Kinesiology 110, 205, 206A, 206B

Physical Education (all activity courses)

### **LIBERAL ARTS**

(all courses, except American Sign Language 110, 111, 210, 211, 220, English 225, 239, and 250, French 285, and Spanish 285, or those listed under Non-Optional Pass/No Pass classes)

### **SCIENCE, ENGINEERING, & MATH**

Anatomy and Physiology 120, 150, 151, 200, 201

Biology 100, 105, 110, 115, 120, 200, 201, 202

Botany 120

Chemistry 100, 110, 111

Computer and Information Sciences (all courses, except CIS 160, 162, 164, 170A, 170B, 170E, 170F, 170G, 170H, 170I, 170K, 170L, 170P, 170R, 170S, 185, 200A, 207, 231, 286, 288, 292)

Earth Science 101, 102, 104, 104L, 106, 110

Energy 100

Environmental Policy 200

## PASS/NO PASS CLASSES

Geography 101, 101L, 102, 103, 105, 140, 160  
Geology 100, 101, 102, 102L, 103, 103L, 105L, 120, 201, 204, 207, 208,  
209  
Mathematics 20, 40, 60, 70, 75, 80, 80A, 80B, 105, 110A, 110B, 112, 114,  
115, 116, 140, 170  
Microbiology 200  
Physical Science 100  
Physics 100  
Zoology 120

### STUDENT ACCESSIBILITY SERVICES SERVICES

Access Learning 101

### TECHNOLOGY

Architecture (all courses except for ARCH 101, 110, 112, 222)  
Automotive Collision Repair 51, 52, 53, 54, 55, 56, 57, 58L, 59F, 59M,  
59P, 59U, 61, 61L, 62, 63, 64, 65, 66, 67, 68L, 73, 74, 75, 76, 77, 79L, 80,  
83A, 83P, 83U, 86, 88, 98, 99, 181, 182, 183, 188, 281, 282, 283, 285, 286,  
287, 288  
Automotive Mechanical Repair 5, 54, 55, 60, 73, 74, 80, 98, 99, 100, 109,  
110, 111, 120, 121, 130, 140, 150, 151, 160, 161, 170, 179, 180, 181, 190,  
193, 194, 195, 210, 211, 280, 281  
Cosmetology 54, 55, 60A, 70A  
Engineering Design Technology 102, 106, 137, 138, 139, 237, 267, 299  
Machine Tool Technology 51, 52, 56, 57, 59, 62, 78, 91L, 92L, 94L, 95L,  
100, 111, 112, 168  
Manufacturing Technology 53, 54  
Plastics/Composites Manufacturing Technology 53, 59, 61, 63L, 67, 68,  
70, 72, 76, 98, 99, 100, 221  
Welding 43, 44, 52, 53, 98, 99, 100, 120, 130, 200, 220, 240L, 250L  
Woodworking Manufacturing Technology 1, 43, 44, 80, 98, 99, 100,  
101, 102L, 120, 182L, 183, 211, 212, 222, 223, 224, 228L, 229L, 231, 232,  
233, 235, 237, 239L, 246, 249L, 250, 252, 258, 269L, 281, 282

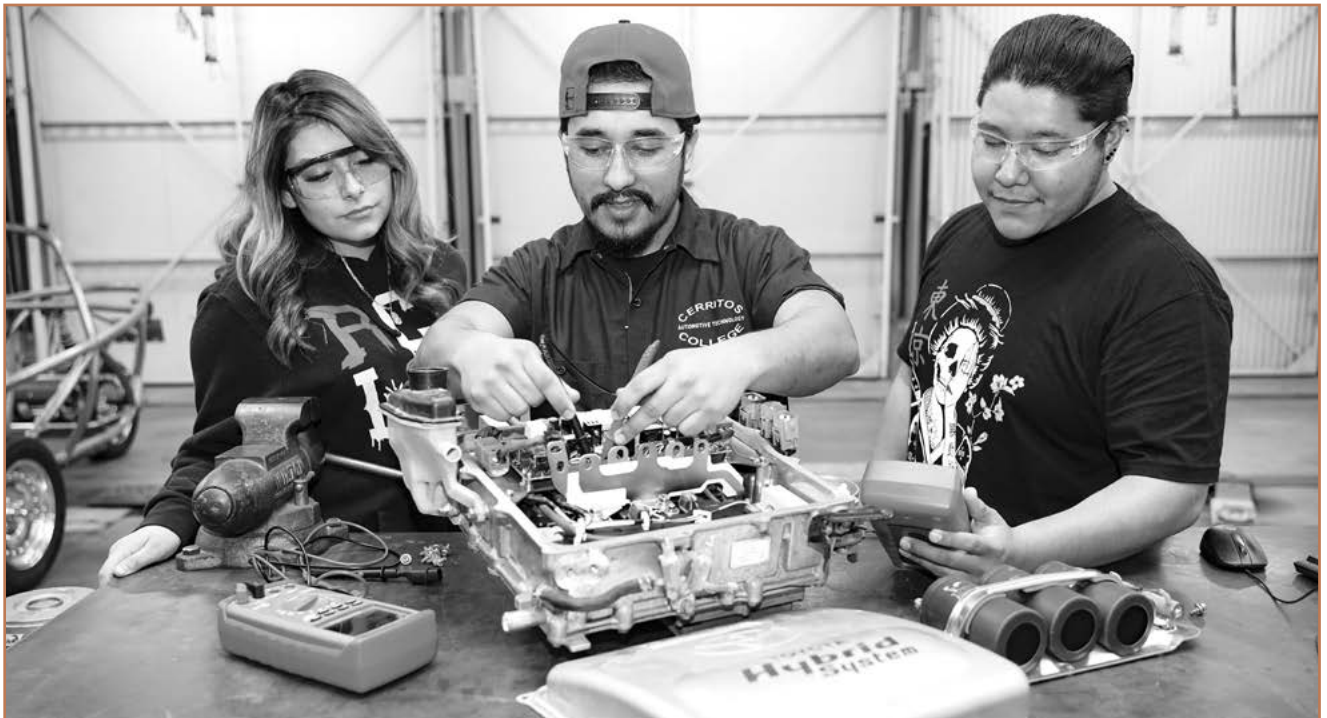

# COURSE REPEATABILITY

Effective Fall 2013, repeatability in Dance, Drama, Physical Education, Visual Arts, and most Music courses has been changed. Intercollegiate Athletics and some Music and Theater courses that are required for transfer programs are the only courses in these disciplines that will remain repeatable; all other courses previously offered as repeatable will be offered as single enrollment courses. There will be a notation after the course description if the course is allowed to be repeated.

The college has developed Families of Courses. The Families of Courses include old and new courses related in content (see below for Families of Courses listed by department). A family of courses may consist of more than four courses, but students are limited to a maximum of four courses in any family. Further, all grades, including “W”s, will count toward the four-course enrollment limitation. Students can repeat Art, Dance, Drama, Music, and PE courses that are included in Families of Courses in which a grade of “NP”, “D”, or “F” was earned or a “W” was assigned; however, all enrollments count toward the four-enrollment maximum for each family of courses.

## FAMILIES OF COURSES

### **ART AND DESIGN**

#### *3D Animation*

Art 191A, 191B, 195

#### *Calligraphy*

Art 180, 181, 183A, 183B, 287A, 287B

#### *Ceramics*

Art 150, 151, 152, 153, 154, 252, 253

#### *Computer Graphics*

Art 184, 186, 189L, 284

#### *Digital Painting*

Art 196

#### *Drawing*

Art 111, 114, 183, 185, 285

#### *Foundation Design Principles*

Art 110, 120, 121

#### *Graphic Design*

Art 184, 284

#### *Lettering and Typography*

Art 182A, 182B

#### *Life Drawing*

Art 112, 213, 214, 232

#### *Life Painting*

Art 237, 238, 239

#### *Motion Graphics*

Art 198

#### *Motion Picture Editing*

Art 192, 192B

#### *Multimedia Design*

Art 194

#### *Painting*

Art 130A, 130B, 136, 231

#### *Print Making*

Art 116, 117, 218, 219

#### *Water Coloring*

Art 133A, 133B, 134, 135

### **COMMUNICATIONS STUDIES**

#### *Forensic Activity*

Communications Studies 231, 232, 233

### **COUNSELING**

#### *Educational Planning*

Counseling 101A, 101B, 101C

### **DANCE**

#### *Adaptive Dance*

Dance 102

#### *Ballet*

Dance 106A, 106B, 107

#### *Commercial Dance*

Dance 110, 124, 126

#### *Dance Composition*

Dance 130, 130A, 130B

#### *Dance Documentation*

Dance 131, 132

#### *Formal Dance Performance*

Dance 133, 134, 136, 150

#### *Informal Dance Performance*

Dance 50, 135, 151

#### *Introductory Dance*

Dance 105

#### *Modern Dance*

Dance 108A, 108B, 108C

#### *Partnering*

Dance 120, 121, 125

#### *Tap Dance*

Dance 142, 143

#### *Theatrical Dance*

Dance 112, 140, 141, 144

#### *World Dance*

Dance 109, 122, 123

### **FILM**

#### *Motion Picture*

Film 101, 104, 107, 293

#### *Television*

Film 102, 103

### **JOURNALISM**

#### *College Newspaper*

Journalism 107, 107A, 107B, 107C, 107D

### **LIBRARY**

#### *Library Research*

Library 100, 101

### **MUSIC**

#### *Guitar Studies*

Music 120, 121, 122, 123

#### *Piano*

Music 112, 113, 115, 144

#### *Vocal Studies*

Music 116, 117, 118, 119, 143

### **PHYSICAL EDUCATION**

#### *Adapted Activities*

PEX 100, 100A

#### *Adapted Aquatics*

PEX 105, 106, 106A

#### *Adapted Fitness*

PEX 101, 102, 104, 109

#### *Adapted Individual Sports*

PEX 108

#### *Adapted Muscular Conditioning*

PEX 103, 103A

#### *Adapted Team Sports*

PEX 107, 107A

#### *Aerobics*

PEX 110, 111, 112, 113

#### *Badminton*

PEX 161, 162, 261

# COURSE REPEATABILITY

## *Baseball*

PEX 163, 263

## *Basketball*

PEX 165, 166, 265, 266

## *Bowling*

PEX 167, 267

## *Cardiovascular Fitness*

PEX 118, 119, 120, 121, 122, 132

## *Cheer*

PEX 169, 170, 171, 271

## *Football*

PEX 172, 272, 274

## *General Fitness*

PEX 124, 126, 130

## *Golf*

PEX 176, 276

## *Indoor Fitness*

PEX 134, 135, 136

## *Muscular Conditioning*

PEX 145, 245, 246

## *Pilates*

PEX 155, 156, 157

## *Self Defense*

PEX 147, 148, 149, 150, 249

## *Soccer*

PEX 177, 178, 179, 278

## *Softball*

PEX 181, 281, 282

## *Swimming*

PEX 184, 185, 186, 284, 285

## *Tennis*

PEX 188, 189, 288, 289

## *Volleyball*

PEX 191, 192, 291, 292

## *Walking, Jogging and Running*

PEX 138, 139, 140, 141, 142, 240

## *Water Aerobics*

PEX 116, 117

## *Wrestling*

PEX 194

## *Yoga*

PEX 151, 152, 153

## **THEATER**

### *Acting*

Theatre 107, 110, 111, 212, 213, 216

### *Costuming*

Theatre 144, 221, 221A

### *Crew*

Theatre 109, 133, 134

### *Improvisation*

Theatre 108, 117, 208

### *Make-Up*

Theatre 123, 123A

### *Musical Theater*

Theatre 105, 146, 147

### *Portable Entertainment*

Theatre 223, 224, 225

### *Rehearsal and Performance*

Theatre 130, 131, 132

### *Touring Theater*

Theatre 136, 137



# ATTENDANCE AND GRADING

## ATTENDANCE

It is the responsibility of students to attend classes regularly and apply themselves to the college studies in which they are enrolled. When students have been absent due to illness, they should report to their instructor to explain the absence. **Students not in attendance or late for the first class meeting are subject to drop. Students who are absent in excess of 10% of the total class hours are subject to drop. Students who are absent during the course add period are subject to drop.** Certain academic and career technical education areas may have stricter attendance requirements. Listed below are two types of absences which permit the making up of work missed, provided that the work is of such a nature that it can be made up.

1. **AUTHORIZED ABSENCE:** For an approved educational field trip or school activity.
2. **EXCUSED ABSENCE:** For illness, injury, or quarantine.

NO CREDIT WILL BE GIVEN FOR A CLASS IN WHICH A STUDENT IS NOT OFFICIALLY ENROLLED. Students must attend the first class meeting or their names may be removed from the roll to allow another student seeking admission to enter. If a student is unable to attend the first class meeting, the instructor must be notified.

## REMOVAL FROM CLASS

A student may be involuntarily removed from a course due to excessive absences, failure to meet prerequisite(s), or as a result of official disciplinary action (California Code of Regulations, Title 5, Section 55003).

## GRADING

Accomplishment in course work is indicated by the following symbols:

Symbol	Definition	Grade Point
A	Excellent . . . . .	4
B	Good . . . . .	3
C	Satisfactory . . . . .	2
D	Passing, less than satisfactory . . . . .	1
F	Failing (earned) . . . . .	0
FW	Failing, due to lack of participation and failure to withdraw . . . . .	0
I	Incomplete . . . . .	-
P	Pass (at least satisfactory, the equivalent of a "C;" units awarded not counted in GPA) . . . . .	-
NP	No Pass (less than satisfactory or failing; units not counted in GPA) . . . . .	-
EW	Extenuating Withdrawal (without penalty) . . . . .	-
MW	Military Withdrawal (without penalty) . . . . .	-
W	Withdrawal . . . . .	-
RD*	Report Delayed . . . . .	-

\* The RD symbol is used when there is a delay in reporting the grade of a student due to circumstances beyond the control of the student. It is a temporary notation to be replaced by a permanent symbol as soon as possible. RD shall not be used in calculating grade point averages.

## INCOMPLETE

**Students are not to re-enroll or audit a course in which a grade of "I" has been recorded.** Incomplete academic work for unforeseeable, emergency, and justifiable reasons at the end of the term may result in an "I" symbol being entered in the student's record. The condition for removal of the "I" shall be stated by the instructor in a written record. This record shall contain the conditions for removal of the "I" and the grade assigned in lieu of its removal. This record must be given to the student with a copy on file with the Admissions and Records Office until the "I" is made up or the time limit has passed. A final grade shall be assigned when the work stipulated has been completed and evaluated, or when the time limit for completing the work has passed. The "I" may be made up no later than one year following the end of the term in which it was assigned. The "I" symbol shall not be used in calculating units attempted, nor for grade points. A student may petition for a time extension due to unusual circumstances by completing a petition form from the Admissions and Records Office.

## GRADE CHANGES

The determination of the student's grade by the instructor shall be final in the absence of mistake, fraud, bad faith, or incompetency. The correction of a grade given shall only be allowed for a request initiated within one year following the end of the term in which it was assigned. Exceptions to the one-year limit on grade changes may be requested by petition of the student in extenuating circumstances. A formal petition must be submitted to the Academic Standards Committee. Extenuating circumstances are verified cases of accident, illness, or other circumstances beyond the control of the students (Title 5, Section 55760, Board Policy 4231).

## GRADE REPORTS

To view your grades, log in to your MyCerritos account and select "Student Center", followed by "My Academics", and finally "Unofficial Transcript". Grades are not mailed to students.

# FINANCIAL ASSISTANCE

## FINANCIAL AID INFORMATION

The Financial Aid Office is available online to answer financial aid questions and assist students with applying for financial aid.

### Services:

◆ **Financial Aid has two options for submitting required documents that are listed on your To Do List on MyCerritos:**

- 1) 2019-2020 documents can be emailed to [finaid@Cerritos.edu](mailto:finaid@Cerritos.edu).
- 2) 2020-2021 documents can be submitted online via student forms. Use the link on the MyCerritos To Do List.

◆ **Online Video Clips** about financial aid topics can be viewed at <https://cerritos.financialaidtv.com>.

◆ **Financial Aid Staff** are available to assist with the following:

- Submit a Free Application for Federal Student Aid (FAFSA)
- Submit a California Dream Act Application (CADAA)
- Check your To Do List in MyCerritos
- IRS Data Retrieval
- View disbursements via MyCerritos
- Activate Cerritos Falcon Card
- Apply for a loan
- Accept/Decline loans

### Contact Information:

**Office Hours:** Please visit our website for hours of operation.

**Website:** [www.cerritos.edu/finaid](http://www.cerritos.edu/finaid)

**Phone:** (562) 860-2451, ext. 2397

**E-mail:** [finaid@cerritos.edu](mailto:finaid@cerritos.edu)

**Fax:** (562) 467-5035

## FINANCIAL AID PROCESS

Apply every academic year. Applications cover Fall, Spring, and Summer. Applications become available in October.

### 1 Apply

- Submit FAFSA at [www.fafsa.gov](http://www.fafsa.gov) or Dream Act Application at [www.caldreamact.org](http://www.caldreamact.org)
- List the federal school code for Cerritos College: 001161

### 2 Submit Forms

- View To Do List on MyCerritos
- Submit required forms electronically

### 3 Review Awards

- For award notification, check your message center on MyCerritos
- You must meet Satisfactory Academic Progress (SAP) standards to receive awards

### 4 Receive Disbursement

- Receive your Refund Selection Kit
- The Financial Aid Office will disburse your financial aid
- View account activity for refund status

## IMPORTANT POINTS OF SATISFACTORY ACADEMIC PROGRESS (SAP)

To be eligible for federal and state financial aid funds (excluding the California College Promise Grant\*), a student must make satisfactory academic progress. The Financial Aid Office at Cerritos College has established the following Satisfactory Academic Progress (SAP) standards to determine if a student is making satisfactory academic progress.

### Grade Point Average (GPA) Requirement

You must maintain a 2.0 cumulative Grade Point Average (GPA).

### Maximum Time Frame Requirement

Students must complete their educational program within a maximum time frame of 150% of the published program's required units at Cerritos College. For example, associate in arts degree and transfer programs generally require 60 units. Therefore, 150% of those programs would be 90 units (60 units x 1.5).

### Unit Completion Requirement – Pace of Progress

Students are required to complete 67% of the units they have attempted. The cumulative units completed will be divided by the cumulative units attempted to calculate the pace of progress. All units are considered in his calculation. Units for which a grade of W, FW, NP, NC, and/or F was received are considered as units attempted, but not completed.

\*Students must meet institutional academic and progress standards for the California College Promise Grant.



# ADMISSION AND ENROLLMENT OF DUAL ENROLLED MINORS

**Special Admit Minors are students enrolled in grades K-12 without high school diplomas, who can benefit from "advanced scholastic or career/technical work."**

## HIGH SCHOOL JUNIORS AND SENIORS

1. The high school principal or designee must recommend and give consent with signature on the Dual Enrollment Form that the student would benefit from college instruction.
2. A parent/guardian must approve student's participation and give consent by signing the Dual Enrollment Form. Signature of the parent/guardian also acknowledges that the student will conform to all College policies and procedures.

### Academic Eligibility

- Students planning to enroll in degree appropriate courses must have a cumulative high school grade point average of 2.0 or higher shown on their most recent school transcript.
- For all courses attempted, students must complete the appropriate College assessment process and meet the stated prerequisite and/or co-requisite for the desired course.
- Students who require accommodations due to a disability should make arrangements through their K-12 school district, in consultation with the Student Accessibility Services (SAS) Office at Cerritos College. For more information, please visit [www.cerritos.edu/sas](http://www.cerritos.edu/sas).

### Limitations on Enrollment

- A high school junior or senior student may be permitted to enroll in up to 8 units. Exceptions may be made, subject to consideration and approval by the Dean of Admissions, Records, and Services.
- Students may not enroll in pre-collegiate courses (1-99) or physical education courses.
- Students may not enroll in a College course to alleviate a high school deficiency.
- Students who have previously enrolled and who have dropped their courses and/or have not made satisfactory progress will not be allowed to continue in the Dual Enrollment Program.
- Students will not receive priority enrollment status and will be charged all applicable fees, with the exception of the California Community College in-state per unit enrollment fee.

## ELEMENTARY AND SECONDARY STUDENTS THROUGH THE 10TH GRADE

1. The school principal or designee must recommend and give consent with signature on the Dual Enrollment Form that the student would benefit from college instruction.
2. A parent/guardian must approve student's participation and give consent by signing the Dual Enrollment Form. Signature of the parent/guardian also acknowledges that the student will conform to all College policies and procedures.

Cerritos College will admit highly gifted elementary students and secondary students through the 10th grade level for enrollment to the College if they are eligible to participate based on the following criteria:

### Academic Eligibility

- Students must have a cumulative school grade point average of 2.5, or higher, as reflected on the most recent school transcript.
- For all courses attempted, the students must complete the appropriate College assessment process and meet the stated prerequisite and/or co-requisite for the desired course.
- Students who require accommodations due to a disability should make arrangements through their K-12 school district, in consultation with the Student Accessibility Services (SAS) Office at Cerritos College. For more information, please visit [www.cerritos.edu/sas](http://www.cerritos.edu/sas).

### Limitations on Enrollment

- Students in grades K-10 may be permitted to enroll in up to 4 units. Exceptions may be made, subject to consideration and approval by the Dean of Admissions, Records, and Services. Enrollment in courses is based on space availability, and the College instructor's signature is required prior to enrollment.
- Students may not enroll in pre-collegiate courses (1-99) or physical education courses.
- Students may not enroll in a College course to alleviate a high school deficiency.
- Students who have previously enrolled and who have dropped their courses and/or have not made satisfactory progress will not be allowed to continue in the Dual Enrollment Program.
- Students will not receive priority enrollment status and will be charged all applicable fees, with the exception of the California Community College in-state per unit enrollment fee.

## SUMMER ENROLLMENT OF K-12 STUDENTS

In addition to the above, minor students wishing to attend summer session must meet the additional criteria:

- The student demonstrates adequate preparation in the discipline to be studied.
- Pre-collegiate courses in English and mathematics may be taken if the student has exhausted all opportunities to enroll in an equivalent course at their school of attendance.

### TO ATTEND CERRITOS COLLEGE AS A DUAL ENROLLMENT MINOR STUDENT, PLEASE FOLLOW THE STEPS BELOW:

1. Complete the Dual Enrollment Form and the Cerritos College Admission Application.
2. Review class(es) of choice, complete SRT(s) and pre-requisites.
3. Dual Enrollment Minors (K-10) must obtain the college instructor's signature prior to enrollment.

It is recommended that Dual Enrollment students (11-12 graders) meet with a Cerritos College academic counselor and participate in the New Student Orientation.

For more information, please call (562) 860-2451, ext. 2211.

# OFFICE OF INTERNATIONAL STUDENT SERVICES



## **Cerritos College is a Student and Exchange Visitor Program (SEVP) certified and approved institution for nonimmigrant students.**

*The Office of International Student Services (OISS) welcomes international students to Cerritos College. Whether planning to achieve an Associate Degree and/or transfer to top universities, OISS is committed in assisting all students to reach their goal(s)! Visit the Office of International Student Services, located in the Santa Barbara Building, for the following services:*

**International Admission and Counseling Assistance:** Assist F-1 international students with the admission process, academic advisement, orientation, registration, and cultural adjustment to the United States, Cerritos College, and our surrounding communities.

**Intensive English Program (IEP):** Cerritos College welcomes international students to develop English skills while introducing them to the American experience and to the diverse cultures of Southern California. Students completing Cerritos College IEP will have the opportunity to continue their education by transferring into the academic program for completion of an Associate of Arts degree and/or to transfer to a university.

Questions may be directed to the Office of International Student Services by phone at (562) 860-2451, ext. 2133, or by email at: [oiss@cerritos.edu](mailto:oiss@cerritos.edu). Please visit our website at [www.cerritos.edu/oiss](http://www.cerritos.edu/oiss) for additional information or on Facebook at Cerritos College Office of International Student Services.

## APPLICATION REQUIREMENTS

The following documents are required for admission to Cerritos College:

- International Student Admission Application (your name must appear the same as in your passport)
- A \$50 processing fee payable to Cerritos College
- Notarized Statement of Support (must be completed by a financial sponsor)
- Bank Certification (verification on bank letterhead, signed by a bank official, showing at least \$22,000, or equivalent, is available to the student). Personal checks will not be accepted for payment of tuition and fees.
- Tuberculosis (TB) exam results
- Transcripts (proof of high school graduation)/High School Diploma
- TOEFL, STEP, iTEP, and/or equivalent Cerritos College Placement Test (not required for students applying for the Intensive English Program)
- Copies of Passport, Visa, and I-94
- Copies of ALL I-20s (both SEVIS and Non-SEVIS I-20s)
- Transfer Authorization (if transferring from U.S. college or language school)
- Purchase of Medical Insurance: Cerritos College international students are required to purchase college-approved coverage from the Student Insurance Company - more information can be found on our website at <https://www.cerritos.edu/international/medical-insurance-requirement-1.htm>.
- Dependents: Attach a copy of the passport, marriage certificate, and/or birth certificate for each dependent. All dependents are required to have health insurance. Add \$3,000 per dependent to the Bank Certification.
- SEVIS I-20 fee of \$200 (preferred payment by credit card on the internet at [www.fmjfee.com](http://www.fmjfee.com)).

**Note:** We will assist students with other non-immigrant visa status (i.e., B-2, F-2, J-1, etc.) to change to F-1 student status.

**International Student Advisement:** Assist F-1 international students to stay in compliance with the United States Citizenship and Immigration Services (USCIS) and other U.S. and foreign governmental agencies while enrolled in full-time status at Cerritos College.

**Workshops and Programs:** Provide academic and immigration workshops as well as programs and activities to enhance student academic, personal, and cultural experiences.

**Global Studies Club:** A club run by students for students. We welcome all students to join for development of social and cultural skills, educational and professional experiences, and most importantly: to make friends from all around the world!

## F-1 INTERNATIONAL STUDENT REQUIREMENTS

### MAINTAINING F-1 INTERNATIONAL STUDENT REQUIREMENTS

- Enroll in a minimum of **12 units (full-time)** for the Fall and Spring semester
- Maintain a minimum 2.0 grade point average (C grade or better) each semester
- Limit enrollment in online classes to a maximum of 3 units as part of the 12-unit requirement
- Meet with the International Counselor each semester and as needed
- Meet with the International Counselor prior to dropping classes, changing class schedule, or concurrent enrollment at another school
- Enroll for classes on registration appointment date and pay fees by semester deadlines
- Will not work on or off-campus without authorization
- Purchase health insurance from the college approved carrier each academic year
- Notify the OISS of any changes and updates within 10 days on the following personal and college application information: name change, home address, email address, phone numbers, major and field of study, financial support, and dependents information.
- Meet with a Designated School Official (DSO) prior to traveling outside the U.S. and present I-20 and passport.
- File Internal Revenue Form 8843 annually. Download form at: [www.irs.gov/Forms-&-Pubs](http://www.irs.gov/Forms-&-Pubs).
- File state and/or federal income tax if participating in APPROVED on or off-campus employment.
- **Falsification, Plagiarism, and Cheating** are violations of academic dishonesty and such actions are causes for termination of F-1 status and I-20 at Cerritos College.

Beginning May 29, 2015, F-2 children and/or the spouse of an F-1 student in the United States may study part-time in any certified program at an SEVP-certified school, so long as the study does not amount to what regulations define as full-time for F-1 students. For further assistance, please contact the Office of International Student Services at (562) 860-2451, ext. 2133, or via email at [oiss@cerritos.edu](mailto:oiss@cerritos.edu).

Class#	Time	Day	Instructor	Room	Class#	Time	Day	Instructor	Room
--------	------	-----	------------	------	--------	------	-----	------------	------

### FALL 2020 Schedule:

Most classes (including all lecture classes) will take place online during Fall 2020. If a class displays as REMOTE in the schedule, students will be expected to log into the class via Canvas at a specified day/time such as MW 8-9:15am. If the class displays as ONLINE in the schedule, students are permitted to log in to the class via Canvas whenever they are available to complete coursework; however, students must log in for the first time before the census date for the class (see Important Add/Drop Dates on the Admissions & Records webpage) and must complete all assignments by the deadlines established by the class instructor. All students who register for an online class should log in to the Canvas site for additional information about class meetings and course requirements.

Please note that a very limited number of classes will take place on campus during Fall 2020. In the schedule, these on-ground classes will display a specified meeting day/time and a physical room location (e.g., SL 121). Additional information will be provided about specific guidelines for students enrolled in classes scheduled to take place on campus in Fall 2020.

## ACCESS LEARNING

### ACLR 91 - 1.0 UNIT CAREER EXPLORATION FOR THE STUDENT WITH DISABILITIES

Not Transferable

21396 2.0 HRS ARR (OL) Segura,A ONLINE  
Class# 21396 meets 10/19/2020-12/18/2020

### ACLR 101 - 2.0 UNITS INCREASING YOUR ACCESS POTENTIAL

Transferable to CSU

Recommendation: ENGL 52 or ENGL 72 or ESL 152 or equivalent with a grade of "C" or higher or "Pass", or completion of the English assessment/placement process with eligibility for ENGL 100 or ENGL 100S, and satisfactory completion of READ 54 or READ 97 with a grade of "C" or higher or "Pass", or completion of the Reading assessment/placement process with eligibility for "reading exempt".

28147 4.0 HRS ARR (OL) LaVigne,S ONLINE  
Class# 28147 meets 08/17/2020-10/16/2020  
29465 4.0 HRS ARR (OL) Segura,A ONLINE  
Class# 29465 meets 10/19/2020-12/18/2020

## ACCOUNTING

### ACCT 60 - 1.5 UNITS QUICKBOOKS ACCOUNTING

Not Transferable

NOTE: a material fee of \$2.50 is required for ACCT 60

21945 3.0 HRS ARR (OL) Ambriz,L ONLINE  
Note: For class information and orientation, visit the Canvas website.  
Class# 21945 meets 08/17/2020-10/16/2020

### ACCT 61 - 1.5 UNITS TURBO TAX ACCOUNTING

Not Transferable

NOTE: a material fee of \$2.50 is required for ACCT 61

21950 3.0 HRS ARR (OL) Fronke,M ONLINE  
Note: For class information and orientation email instructor at mfronke@cerritos.edu  
Class# 21950 meets 08/17/2020-10/16/2020  
21951 3.0 HRS ARR (OL) Fronke,M ONLINE  
Note: For class information and orientation email instructor at mfronke@cerritos.edu  
Class# 21951 meets 10/19/2020-12/18/2020

### ACCT 100 - 3.0 UNITS INTRODUCTION TO ACCOUNTING

Transferable to CSU

21900 8:00-9:15AM MW Aeryn,T REMOTE  
21901 9:30-10:45AM MW Aeryn,T REMOTE  
21902 11:00-12:15PM MW Tsang,W REMOTE  
21903 7:00-9:50PM T Eliassen,A REMOTE  
21904 7:00-9:50PM M Eliassen,A REMOTE  
21906 9:30-10:45AM TTh Osaki,C REMOTE  
21907 3.0 HRS ARR (OL) Johnson,D ONLINE  
21908 5:30-6:45PM TTh Moloney,P REMOTE  
23561 3.0 HRS ARR (OL) Fronke,M ONLINE  
Note: For class information and orientation, visit the Canvas website.  
27141 3.0 HRS ARR (OL) Johnson,D ONLINE  
27978 1:30-2:45PM MW Moloney,P REMOTE  
24408 3.0 HRS ARR (OL) Fronke,M ONLINE  
Note: For class information and orientation email instructor at mfronke@cerritos.edu  
21911 3.6 HRS ARR (OL) Farina,M ONLINE  
Note: For class information and orientation, visit the Canvas website  
Class# 21911 meets 09/08/2020-12/18/2020  
21948 3.6 HRS ARR (OL) Kisling,K ONLINE  
Class# 21948 meets 09/08/2020-12/18/2020  
25200 2:00-3:30PM TTh Moloney,P REMOTE  
Class# 25200 meets 09/08/2020-12/17/2020

### ACCT 101 - 3.5 UNITS FUNDAMENTALS OF ACCOUNTING I

Transferable to UC, CSU (CAN BUS 2)(CAN BUS SEQ A)

Prerequisite: ACCT 100 or equivalent with a grade of "C" or higher or "Pass".

21912 11:00-12:30PM MW Moloney,P REMOTE  
12:30-1:15PM MW Moloney,P REMOTE  
21914 3.0 HRS ARR (OL) Johnson,D ONLINE  
+ 2.0 HRS ARR (OL) Johnson,D ONLINE  
21918 7:30-9:00PM MW Tsang,W REMOTE  
9:00-9:45PM MW Tsang,W REMOTE  
21920 8:30-10:00AM TTh Aeryn,T REMOTE  
10:00-10:45AM TTh Aeryn,T REMOTE  
21922 3.0 HRS ARR (OL) Fronke,M ONLINE  
+ 2.0 HRS ARR (OL) Fronke,M ONLINE  
21924 5:00-6:30PM TTh Osaki,C REMOTE  
6:30-7:15PM TTh Osaki,C REMOTE  
21916 3.6 HRS ARR (OL) Aviles,S ONLINE  
+ 2.4 HRS ARR (OL) Aviles,S ONLINE  
Class# 21916 meets 09/08/2020-12/18/2020

### ACCT 102 - 3.5 UNITS FUNDAMENTALS OF ACCOUNTING II

Transferable to UC, CSU (CAN BUS 4)(CAN BUS SEQ A)

Prerequisite: ACCT 101 or equivalent with a grade of "C" or higher or "Pass".

21928 3.0 HRS ARR (OL) Fronke,M ONLINE  
+ 2.0 HRS ARR (OL) Fronke,M ONLINE  
21932 11:00-12:30PM MW Aeryn,T REMOTE  
12:30-1:15PM MW Aeryn,T REMOTE  
21934 3.0 HRS ARR (OL) Johnson,D ONLINE  
+ 2.0 HRS ARR (OL) Johnson,D ONLINE  
27755 12:30-2:00PM TTh Tsang,W REMOTE  
2:00-2:45PM TTh Tsang,W REMOTE  
21930 3.6 HRS ARR (OL) Aviles,S ONLINE  
+ 2.4 HRS ARR (OL) Aviles,S ONLINE  
Class# 21930 meets 09/08/2020-12/18/2020

### ACCT 130 - 3.0 UNITS PAYROLL TAX ACCOUNTING

Transferable to CSU

Prerequisite: ACCT 100 or ACCT 101 or equivalent with a grade of Pass or "C" or higher.

21936 3.0 HRS ARR (OL) Castellanos-Gaona,S ONLINE

### ACCT 131 - 3.0 UNITS COMPUTERIZED ACCOUNTING - IBM

Transferable to CSU

Prerequisite: ACCT 100 or ACCT 101 or equivalent with a grade of "C" or higher or "Pass".

NOTE: a material fee of \$4.00 is required for ACCT 131

21937 3.6 HRS ARR (OL) Ambriz,L ONLINE  
Note: Class will meet the first day and the instructor will inform the students of future class meetings.  
Class# 21937 meets 09/08/2020-12/18/2020

### ACCT 133 - 3.0 UNITS SPREADSHEET ACCOUNTING I

Transferable to CSU

Prerequisite: ACCT 100 or equivalent with a grade of "C" or higher or "Pass".

NOTE: a material fee of \$4.00 is required for ACCT 133

21940 3.0 HRS ARR (OL) Johnson,D ONLINE  
Note: For orientation and class information go to [www.cerritos.edu/dljohnson](http://www.cerritos.edu/dljohnson).  
Four on campus visits required over the course of the semester.  
21938 3.6 HRS ARR (OL) Johnson,D ONLINE  
Note: For orientation and class information go to [www.cerritos.edu/dljohnson](http://www.cerritos.edu/dljohnson).  
Four on campus visits required over the course of the semester.  
Class# 21938 meets 09/08/2020-12/18/2020

If a class displays as REMOTE in the schedule, students will be expected to log into the class at a specified day/time (e.g., MW 8-9:15am).  
If the class displays as ONLINE in the schedule, students are permitted to log into the class whenever they are available to complete coursework by the established deadlines.

Students not in attendance or late for the first class meeting are subject to drop.

Class#	Time	Day	Instructor	Room	Class#	Time	Day	Instructor	Room
<b>ACCT 160 - 3.0 UNITS ACCOUNTING FOR QUICKBOOKS FOR CERTIFICATION</b> Not Transferable					<b>AJ 104 - 3.0 UNITS CRIMINAL EVIDENCE</b> Transferable to CSU (CAN AJ 6) Recommendation: An English assessment/placement score into ENGL 100 or ENGL 100S or ENGL 52 with a grade of "C" or higher or "Pass" and satisfactory completion of the Reading assessment/placement process or READ 54 with a grade of "C" or higher or "Pass".				
30369	7:00-9:50PM	Th	Wang,S	REMOTE	20050	3.0 HRS ARR	(OL)	Jimenez,F	ONLINE
<b>ACCT 201 - 3.5 UNITS INTERMEDIATE ACCOUNTING I</b> Transferable to CSU Prerequisite: ACCT 102 or equivalent with a grade of "C" or higher or "Pass".					<b>27315 5:00-6:15PM MW</b> STAFF REMOTE				
21941	5:00-6:30PM	MW	Tsang,W	REMOTE					
	6:30-7:15PM	MW	Tsang,W	REMOTE					
<b>ACCT 220 - 4.0 UNITS ACCOUNTING ETHICS</b> Transferable to CSU Prerequisite: ACCT 101 or equivalent with a grade of "C" or higher or "Pass".					<b>AJ 105 - 3.0 UNITS COMMUNITY RELATIONS AND CULTURAL AWARENESS</b> Transferable to UC, CSU Recommendation: ENGL 52 or ENGL 72 or ESL 152 or equivalent with a grade of "C" or higher, or "Pass" or completion of the English assessment/placement Process with eligibility for ENGL 100 or ENGL 100S and completion of READ 54 or READ 97 with a grade of "C" or higher, or "Pass," or completion of the Reading assessment/placement Process with eligibility for a course above the level or READ 54.				
28138	4.8 HRS ARR	(OL)	Kroll,S	ONLINE	20621	5:00-6:15PM	TTh	Clansy,A	REMOTE
Note: For class information and orientation email instructor at skroll@cerritos.edu Class# 28138 meets 09/08/2020-12/18/2020					27979	3.0 HRS ARR	(OL)	Gomez,R	ONLINE
<b>ACCT 240 - 3.5 UNITS COST ACCOUNTING</b> Transferable to CSU Prerequisite: ACCT 100 or ACCT 101 or equivalent with a grade of "C" or higher or "Pass".					<b>AJ 107 - 3.0 UNITS INTRODUCTION TO CORRECTIONS, PROBATION AND PAROLE</b> Transferable to CSU				
21943	3.0 HRS ARR	(OL)	Castellanos-Gaona,S	ONLINE	23767	3.0 HRS ARR	(OL)	Jimenez,F	ONLINE
	+ 2.0 HRS ARR	(OL)	Castellanos-Gaona,S	ONLINE	30016	3.0 HRS ARR	(OL)	Smith,J	ONLINE
<b>ACCT 250 - 3.0 UNITS INCOME TAX ACCOUNTING</b> Transferable to CSU Prerequisite: ACCT 100 or ACCT 101 or equivalent with a grade of "C" or higher or "Pass".					<b>AJ 110 - 3.0 UNITS PATROL PROCEDURES AND ENFORCEMENT TACTICS</b> Transferable to CSU Recommendation: An English assessment/placement score into ENGL 100 or ENGL 100S or ENGL 52 with a grade of "C" or higher or "Pass" and satisfactory completion of the Reading assessment/placement process or READ 54 with a grade of "C" or higher or "Pass".				
29090	3.6 HRS ARR	(OL)	Kroll,S	ONLINE	21680	3.0 HRS ARR	(OL)	Jimenez,F	ONLINE
Note: For class information and orientation email instructor at skroll@cerritos.edu Class# 29090 meets 09/08/2020-12/18/2020					30492	3.0 HRS ARR	(OL)	Henshaw,T	ONLINE
<b>ACCT 270 - 3.0 UNITS FUNDAMENTALS OF AUDITING</b> Transferable to CSU Prerequisite: ACCT 101 or equivalent with a grade of "C" or higher or "Pass".					<b>AJ 113 - 3.0 UNITS REPORT WRITING PROCEDURES</b> Transferable to CSU Recommendation: ENGL 52 or ENGL 72 or ESL 152 or completion of the English assessment/placement process with eligibility for ENGL 100 or ENGL 100S and READ 54 or READ 97 or READ 102 or completion of the Reading assessment/placement process with eligibility as "Reading Exempt".				
27768	3.6 HRS ARR	(OL)	Kroll,S	ONLINE	30014	3.0 HRS ARR	(OL)	Jimenez,F	ONLINE
Note: For class information and orientation email instructor at skroll@cerritos.edu Class# 27768 meets 09/08/2020-12/18/2020					30015	3.0 HRS ARR	(OL)	Mellana,T	ONLINE
<b>ADMINISTRATION OF JUSTICE</b>									
<b>AJ 101 - 3.0 UNITS INTRODUCTION TO ADMINISTRATION OF JUSTICE</b> Transferable to UC, CSU (CAN AJ 2) Recommendation: An English assessment/placement score into ENGL 100 or ENGL 100S or ENGL 52 with a grade of "C" or higher or "Pass" and satisfactory completion of the Reading assessment/placement process or READ 54 with a grade of "C" or higher or "Pass".					<b>AJ 202 - 3.0 UNITS SUBSTANTIVE LAW</b> Transferable to CSU Prerequisite: AJ 102 or equivalent with a grade of "C" or higher or "Pass". Recommendation: An English assessment/placement score into ENGL 100 or ENGL 100S or ENGL 52 with a grade of "C" or higher or "Pass" and satisfactory completion of the Reading assessment/placement process or READ 54 with a grade of "C" or higher or "Pass".				
20043	3.0 HRS ARR	(OL)	Gomez,R	ONLINE	25506	3.0 HRS ARR	(OL)	Gomez,R	ONLINE
20044	3.0 HRS ARR	(OL)	Jimenez,F	ONLINE	25507	3.0 HRS ARR	(OL)	Collins,J	ONLINE
MANDATORY orientations at www.cerritos.edu/de and also through the class webpage; students must visit both sites					<b>AJ 208 - 3.0 UNITS SPECIAL ISSUES IN LAW ENFORCEMENT</b> Transferable to CSU Recommendation: ENGL 52 or ENGL 72 or ESL 152 or equivalent with a grade of "C" or higher, or "Pass," or completion of the English assessment/placement process with eligibility for ENGL 100 or ENGL 100S and completion of READ 54 or READ 97 with a grade of "C" or higher or "Pass" or completion of the Reading assessment/placement process with eligibility for a course above the level of READ 54.				
20045	3.0 HRS ARR	(OL)	Gomez,R	ONLINE	27148	3.0 HRS ARR	(OL)	Smith,J	ONLINE
20618	6:30-9:00PM	M	Bodmer,R	REMOTE	<b>AJ 220 - 3.0 UNITS CRIMINAL INVESTIGATION</b> Transferable to CSU (CAN AJ 8)				
25988	3.0 HRS ARR	(OL)	Walquist,B	ONLINE	20051	3.0 HRS ARR	(OL)	Gomez,R	ONLINE
<b>AJ 102 - 3.0 UNITS CONCEPTS OF CRIMINAL LAW</b> Transferable to UC, CSU (CAN AJ 4)					20622	3.0 HRS ARR	(OL)	Smith,J	ONLINE
20046	3.0 HRS ARR	(OL)	Henshaw,T	ONLINE	<b>AJ 221 - 3.0 UNITS NARCOTICS AND VICE CONTROL</b> Transferable to CSU Recommendation: An English assessment/placement score into ENGL 100 or ENGL 100S or ENGL 52 with a grade of "C" or higher or "Pass" and satisfactory completion of the Reading assessment/placement process or READ 54 with a grade of "C" or higher or "Pass".				
20619	3.0 HRS ARR	(OL)	Walquist,B	ONLINE	29411	6:30-9:20PM	Th	Clansy,A	REMOTE
<b>AJ 103 - 3.0 UNITS CRIMINAL PROCEDURES</b> Transferable to CSU Recommendation: An English assessment/placement score into ENGL 100 or ENGL 100S or ENGL 52 with a grade of "C" or higher or "Pass" and satisfactory completion of the Reading assessment/placement process or READ 54 with a grade of "C" or higher or "Pass".									
20048	3.0 HRS ARR	(OL)	Walquist,B	ONLINE					
29091	3.0 HRS ARR	(OL)	Collins,J	ONLINE					

If a class displays as **REMOTE** in the schedule, students will be expected to log into the class at a specified day/time (e.g., MW 8-9:15am). If the class displays as **ONLINE** in the schedule, students are permitted to log into the class whenever they are available to complete coursework by the established deadlines.

Students not in attendance or late for the first class meeting are subject to drop.

Class#	Time	Day	Instructor	Room	Class#	Time	Day	Instructor	Room
<b>AJ 222 - 3.0 UNITS JUVENILE PROCEDURES</b> Transferable to CSU Recommendation: An English assessment/placement score into ENGL 100 or ENGL 100S or ENGL 52 with a grade of "C" or higher or "Pass" and satisfactory completion of the Reading assessment/placement process or READ 54 with a grade of "C" or higher "Pass".									
20052	3.0 HRS ARR	(OL)	Wolfe,J	ONLINE	28153	3.0 HRS ARR	(OL)	Narvaez, A	ONLINE
MANDATORY orientations at www.cerritos.edu/de and also through the class webpage; students must visit both sites					<b>ASL 215 - 3.0 UNITS BEGINNING INTERPRETING AND ETHICS 1</b> Transferable to CSU Prerequisite: ASL 210 with a grade of "C" or higher or ""Pass" or equivalent.				
					<b>ASL 220 - 3.0 UNITS DEAF CULTURE</b> Transferable to UC, CSU 12:30-1:50PM TTh Kelly,E REMOTE LAB IS ONE HOUR PER WEEK 30404 3.0 HRS ARR (OL) Hall,C ONLINE				

## AMERICAN SIGN LANGUAGE

<b>ASL 110 - 4.0 UNITS AMERICAN SIGN LANGUAGE I</b> Transferable to UC, CSU									
24566	9:00-10:50AM	TTh	Kelly,E	REMOTE					
	+ 1.0 HRS ARR		Kelly,E	REMOTE					
LAB IS ONE HOUR PER WEEK									
24568	4.0 HRS ARR	(OL)	Morford,V	ONLINE					
	+ 1.0 HRS ARR	(OL)	Morford,V	ONLINE					
LAB IS ONE HOUR PER WEEK									
24570	4.0 HRS ARR	(OL)	Hall,C	ONLINE					
	+ 1.0 HRS ARR	(OL)	Hall,C	ONLINE					
LAB IS ONE HOUR PER WEEK									
24572	9:00-10:50AM	MW	Kelly,E	REMOTE					
	+ 1.0 HRS ARR	(OL)	Kelly,E	REMOTE					
LAB IS ONE HOUR PER WEEK									
24574	4.0 HRS ARR	(OL)	Morford,V	ONLINE					
	+ 1.0 HRS ARR	(OL)	Morford,V	ONLINE					
LAB IS ONE HOUR PER WEEK									
24576	4.0 HRS ARR	(OL)	Delao,J	ONLINE					
	+ 1.0 HRS ARR	(OL)	Delao,J	ONLINE					
24578	4.0 HRS ARR	(OL)	Gough,T	ONLINE					
	+ 1.0 HRS ARR	(OL)	Gough,T	ONLINE					
LAB IS ONE HOUR PER WEEK									
24580	4.0 HRS ARR	(OL)	Hall,C	ONLINE					
	+ 1.0 HRS ARR	(OL)	Hall,C	ONLINE					
LAB IS ONE HOUR PER WEEK									
24582	4.0 HRS ARR	(OL)	Delao,J	ONLINE					
	+ 1.0 HRS ARR	(OL)	Delao,J	ONLINE					
LAB IS ONE HOUR PER WEEK									
26297	5:00-6:50PM	MW	Harper-Johnson,P	REMOTE					
	+ 1.0 HRS ARR	(OL)	Harper-Johnson,P	REMOTE					
LAB IS ONE HOUR PER WEEK									
26299	5:00-6:50PM	TTh	Michelotti,A	REMOTE					
	+ 1.0 HRS ARR		Michelotti,A	REMOTE					
LAB IS ONE HOUR PER WEEK									
<b>ASL 111 - 4.0 UNITS AMERICAN SIGN LANGUAGE II</b> Transferable to UC, CSU Prerequisite: SL 101 or ASL 110 or equivalent with a grade of "C" or higher or "Pass".									
24584	11:00-12:50PM	MW	Kelly,E	REMOTE					
	+ 1.0 HRS ARR		Kelly,E	REMOTE					
LAB IS ONE HOUR PER WEEK									
24586	7:00-8:50PM	TTh	Michelotti,A	REMOTE					
	+ 1.0 HRS ARR		Michelotti,A	REMOTE					
LAB IS ONE HOUR PER WEEK									
30400	4.0 HRS ARR	(OL)	Hall,C	ONLINE					
	+ 1.0 HRS ARR	(OL)	Hall,C	ONLINE					
LAB IS ONE HOUR PER WEEK									
<b>ASL 210 - 4.0 UNITS AMERICAN SIGN LANGUAGE III</b> Transferable to UC, CSU Prerequisite: SL 102 or ASL 111 or equivalent with a grade of "C" or higher or "Pass".									
24588	1:00-2:50PM	MW	Kelly,E	REMOTE					
	+ 1.0 HRS ARR		Kelly,E	REMOTE					
LAB IS ONE HOUR PER WEEK									
<b>ASL 211 - 4.0 UNITS AMERICAN SIGN LANGUAGE IV</b> Transferable to UC, CSU Prerequisite: SL 201 or ASL 210 or equivalent with a grade of "C" or higher or "Pass".									
30402	4.0 HRS ARR	(OL)	Hall,C	ONLINE					
	+ 1.0 HRS ARR	(OL)	Hall,C	ONLINE					

## ANATOMY AND PHYSIOLOGY

<b>A&amp;P 120 - 4.0 UNITS INTRODUCTION TO HUMAN ANATOMY AND PHYSIOLOGY</b> Transferable to UC, CSU Prerequisite: ENGL 52 or ENGL 72 or ESL 152 or equivalent with a grade of "C" or higher or "Pass" or completion of the English assessment/placement process with a score eligible for ENGL 100 or ENGL 100S.									
20031	+ 3.0 HRS ARR	(OL)	Tydell,C	ONLINE					
20033	3.0 HRS ARR	(OL)	Tydell,C	ONLINE					
20034	3.0 HRS ARR	(OL)	Tydell,C	ONLINE					
20610	+ 3.0 HRS ARR	(OL)	Majewski,A	ONLINE					
20611	3.0 HRS ARR	(OL)	Majewski,A	ONLINE					
20612	3.0 HRS ARR	(OL)	Majewski,A	ONLINE					
<b>A&amp;P 150 - 4.0 UNITS INTRODUCTION TO HUMAN ANATOMY</b> Transferable to UC, CSU Prerequisite: ENGL 100 or ENGL 100S or equivalent with a grade of "C" or higher or "Pass." Recommendation: A&P 120 or equivalent with a grade of "C" or higher or "Pass".									
20035	12:30-1:45PM	TTh	Babiar,R	REMOTE					
20036	3.0 HRS ARR	(OL)	Babiar,R	ONLINE					
20037	3.0 HRS ARR	(OL)	Babiar,R	ONLINE					
20038	3.0 HRS ARR	(OL)	Babiar,R	ONLINE					
21791	8:00-10:50AM	M	Yi,M	REMOTE					
29452	6:00-8:50PM	F	Kuo,Y	REMOTE					
30197	2:00-3:15PM	MW	Yi,M	REMOTE					
20613	5:00-6:15PM	MW	Cocca,S	REMOTE					
20614	7:00-9:50PM	M	Yi,M	REMOTE					
20615	7:00-9:50PM	W	Taylor,T	REMOTE					
24290	12:00-2:50PM	F	Kuo,Y	REMOTE					
	3:00-5:50PM	F	Kuo,Y	REMOTE					
28981	3:30-6:20PM	Th	Kennedy,W	REMOTE					
	+ 3.0 HRS ARR	(OL)	Covill,M	ONLINE					
29453	3.0 HRS ARR	(OL)	Covill,M	ONLINE					
29454	3.0 HRS ARR	(OL)	Tamminga,S	ONLINE					
<b>A&amp;P 151 - 4.0 UNITS INTRODUCTION TO HUMAN PHYSIOLOGY</b> Transferable to UC, CSU Prerequisite: A&P 150 or equivalent with a grade of "C" or higher or "Pass". Recommendation: CHEM 100 or equivalent with a grade of "C" or higher or "Pass".									
21221	+ 3.0 HRS ARR	(OL)	Tydell,C	ONLINE					
21223	3:30-6:20PM	T	Babiar,R	REMOTE					
28026	11:00-1:50PM	Th	Huss,B	REMOTE					
	2:00-3:15PM	TTh	Huss,B	REMOTE					
28978	8:00-10:50AM	Th	Babiar,R	REMOTE					
30198	5:00-6:15PM	MW	Maltz,N	REMOTE					
30199	7:00-9:50PM	M	Maltz,N	REMOTE					
30200	7:00-9:50PM	W	Maltz,N	REMOTE					
<b>A&amp;P 200 - 5.0 UNITS HUMAN ANATOMY</b> Transferable to UC, CSU (CAN BIOL 10)(CAN BIOL SEQ B) Prerequisite: A four-unit college-level biological science with lab course with a grade of "C" or higher or "Pass". Recommendation: ENGL 100 or ENGL 100S or equivalent with a grade of "C" or higher or "Pass".									
20039	9:00-10:15AM	MW	Lepere,S	REMOTE					
20040	11:00-1:50PM	MW	Lepere,S	REMOTE					
20041	8:00-10:50AM	TTh	Lepere,S	REMOTE					

If a class displays as **REMOTE** in the schedule, students will be expected to log into the class at a specified day/time (e.g., MW 8-9:15am). If the class displays as **ONLINE** in the schedule, students are permitted to log into the class whenever they are available to complete coursework by the established deadlines.

Students not in attendance or late for the first class meeting are subject to drop.

Class#	Time	Day	Instructor	Room	Class#	Time	Day	Instructor	Room
--------	------	-----	------------	------	--------	------	-----	------------	------

## ANTHROPOLOGY

### ANTH 100 - 3.0 UNITS CULTURAL ANTHROPOLOGY

Transferable to UC, CSU (CAN ANTH 4)  
 Recommendation: ENGL 52 or ENGL 72 or ESL 152 or equivalent with a grade of "C" or higher or "Pass" or completion of the English assessment/placement process with eligibility for ENGL 100 or ENGL 100S and READ 54 or READ 97 or READ 102 with a grade of "C" or higher, or "Pass" or completion of the Reading assessment/placement process with a score of "Reading Exempt".

20053	8:00-9:15AM	MW	Rigby,J	REMOTE
22380	3.0 HRS ARR	(OL)	Garcia,S	ONLINE
27758	6:30-7:45AM	TTh	Rigby,J	REMOTE
20055	12:30-1:45PM	TTh	Rigby,J	REMOTE
30017	3.0 HRS ARR	(OL)	Vechayiem,D	ONLINE
21365	3.6 HRS ARR	(OL)	Abbruzzese,M	ONLINE

Class# 21365 meets 09/08/2020-12/18/2020

### ANTH 110 - 3.0 UNITS INTRODUCTION TO FORENSIC ANTHROPOLOGY

Transferable to CSU, UC transferability pending  
 Recommendation: ANTH 115 or ANTH 115L or A&P 120 with a grade of "C" or higher or "Pass".

22879	3.0 HRS ARR	(OL)	Abbruzzese,M	ONLINE
	+ 1.0 HRS ARR	(OL)	Abbruzzese,M	ONLINE

### ANTH 115 - 3.0 UNITS PHYSICAL ANTHROPOLOGY

Transferable to UC, CSU (CAN ANTH 2)

20057	6:30-7:45AM	MW	Rigby,J	REMOTE
20058	3.0 HRS ARR	(OL)	Vechayiem,D	ONLINE
20059	9:30-10:45AM	MW	Rigby,J	REMOTE
20060	8:00-9:15AM	TTh	Rigby,J	REMOTE
20623	6:30-9:20PM	W	Fierro,B	REMOTE
21260	3.0 HRS ARR	(OL)	Abbruzzese,M	ONLINE
30372	3.6 HRS ARR	(OL)	Abbruzzese,M	ONLINE

Class# 30372 meets 09/08/2020-12/18/2020

Class# 21332 meets 09/08/2020-12/18/2020

Class# 21332 meets 09/08/2020-12/18/2020

Class# 26734 meets 09/08/2020-12/18/2020

Class# 23870 meets 08/17/2020-10/16/2020

### ANTH 115L - 1.0 UNIT INTRODUCTION TO PHYSICAL ANTHROPOLOGY LAB

Transferable to UC, CSU  
 Prerequisite: ANTH 115 with a grade "C" or higher or "Pass" or concurrent enrollment.

21689	3.0 HRS ARR	(OL)	Abbruzzese,M	ONLINE
21831	1:00-3:50PM	Th	Little,L	REMOTE
22284	3.0 HRS ARR	(OL)	Garcia,S	ONLINE
24436	2:00-4:50PM	F	Little,L	REMOTE
29728	3.0 HRS ARR	(OL)	Vechayiem,D	ONLINE

### ANTH 170 - 3.0 UNITS INTRODUCTION TO LANGUAGE AND CULTURE

Transferable to UC, CSU  
 Recommendation: Satisfactory completion of English & Reading assessment/placement Process or ENGL 52 or ENGL 72 or ESL 152 or equivalent with a grade of "C" or higher or "Pass" and READ 54 or READ 97 or equivalent with a grade of "C" or higher or "Pass".

22575	3.0 HRS ARR	(OL)	Abbruzzese,M	ONLINE
-------	-------------	------	--------------	--------

### ANTH 203 - 3.0 UNITS THE ANTHROPOLOGY OF MAGIC, WITCHCRAFT, AND RELIGION

Transferable to UC, CSU  
 Recommendation: Satisfactory completion of English & Reading assessment/placement Process or ENGL 52 or ENGL 72 or ESL 152 or equivalent with a grade of "C" or higher or "Pass" and READ 54 or READ 97 or equivalent with a grade of "C" or higher or "Pass".

30373	9:30-10:45AM	TTh	Rigby,J	REMOTE
-------	--------------	-----	---------	--------

## ARCHITECTURE

### ARCH 110 - 3.0 UNITS INTRODUCTION TO ARCHITECTURE AND ENVIRONMENTAL DESIGN

Transferable to UC, CSU  
 Please read the technical standards relevant to this department at <http://cms.cerritos.edu/technology/standards.htm>

27592	4:30-5:50PM	TTh	Van,H	REMOTE
28944	3.0 HRS ARR	(OL)	Rother,E	ONLINE

### ARCH 111 - 3.0 UNITS ARCHITECTURAL DRAFTING AND DESIGN I

Transferable to CSU  
 NOTE: a material fee of \$6.00 is required for ARCH 111

26129	3.0 HRS ARR	(OL)	Rother, E.	ONLINE
	3.0 HRS ARR	(OL)	Rother, E.	ONLINE

### ARCH 112 - 3.0 UNITS HISTORY OF ARCHITECTURE

Transferable to UC, CSU

20062	3.0 HRS ARR	(OL)	Paul,D	ONLINE
20625	3.0 HRS ARR	(OL)	Paul,D	ONLINE
26809	3:30-6:20PM	T	Phinney,P	ONLINE
29985	3.0 HRS ARR	(OL)	Greas,M	ONLINE

### ARCH 113 - 4.0 UNITS BUILDING CODES

Transferable to CSU

28942	12:30-2:20PM	TTh	Van,H	REMOTE
-------	--------------	-----	-------	--------

### ARCH 121 - 3.0 UNITS ARCHITECTURAL DRAFTING AND DESIGN II

Transferable to CSU  
 Prerequisite: ARCH 111 or equivalent with a grade of "C" or higher or "Pass", or appropriate work experience.

NOTE: a material fee of \$6.00 is required for ARCH 121

30347	3.0 HRS ARR	(OL)	Morales,T	ONLINE
	3.0 HRS ARR	(OL)	Morales,T	ONLINE

### ARCH 122 - 2.0 UNITS ARCHITECTURAL DELINEATION

Transferable to UC, CSU  
 NOTE: a material fee of \$6.00 is required for ARCH 122

29986	3.0 HRS ARR	(OL)	Phinney,P,T	ONLINE
	3.0 HRS ARR	(OL)	Phinney,P,T	ONLINE

### ARCH 123 - 4.0 UNITS INTRODUCTION TO 2D COMPUTER AIDED DRAFTING

Transferable to CSU  
 NOTE: a material fee of \$6.00 is required for ARCH 123

29988	3.0 HRS ARR	(OL)	Rother,E	ONLINE
	+ 3.0 HRS ARR	(OL)	Rother,E	ONLINE

### ARCH 212 - 3.0 UNITS ARCHITECTURAL DESIGN THEORY I

Transferable to UC, CSU  
 NOTE: a material fee of \$6.00 is required for ARCH 212

22739	3.0 HRS ARR	(OL)	Rother, E.	ONLINE
	3.0 HRS ARR	(OL)	Rother, E.	ONLINE

## ART AND DESIGN

### ART 100 - 3.0 UNITS INTRODUCTION TO WORLD ART

Transferable to UC, CSU  
 Recommendation: ENGL 52, or ENGL 72 or ESL 152 and READ 54 or READ 97 or equivalent with grades of "C" or higher or "Pass".

22533	3.0 HRS ARR	(OL)	Goldsmith,M	ONLINE
20063	3.0 HRS ARR	(OL)	Robertson,C	ONLINE
28217	3.0 HRS ARR	(OL)	Mac Devitt,J	ONLINE

### ART 101 - 3.0 UNITS ART HISTORY I: PREHISTORY TO GOTHIC

Transferable to UC, CSU (CAN ART 2)  
 Recommendation: ENGL 52, or ENGL 72 or ESL 152 and READ 54 or READ 97 or equivalent with grades of "C" or higher or "Pass".

22102	3.0 HRS ARR	(OL)	Robertson,C	ONLINE
22534	3.6 HRS ARR	(OL)	Vitela,L	ONLINE

Class# 22534 meets 08/17/2020-11/27/2020

If a class displays as **REMOTE** in the schedule, students will be expected to log into the class at a specified day/time (e.g., MW 8-9:15am). If the class displays as **ONLINE** in the schedule, students are permitted to log into the class whenever they are available to complete coursework by the established deadlines.

Students not in attendance or late for the first class meeting are subject to drop.

Class#	Time	Day	Instructor	Room	Class#	Time	Day	Instructor	Room
<b>ART 102 - 3.0 UNITS ART HISTORY II: RENAISSANCE TO ROCOCO</b> Transferable to UC, CSU (CAN ART 4) Recommendation: ENGL 52 or ENGL 72 or ESL 152 and READ 54 or READ 97 or equivalent with grades of "C" or higher or "Pass".					28016	1:00-2:00PM 2:00-3:50PM	MW MW	Bersaglieri,A Bersaglieri,A	REMOTE REMOTE
26174	3.6 HRS ARR	(OL)	Vitela,L	ONLINE	Asynchronous/Hybrid classes meet the first day of each week for a mandatory Zoom meeting. Students have an optional second day of the week for office hours or discussions of the assigned course work.				
<b>ART 103 - 3.0 UNITS ART HISTORY III: NEOCLASSICAL TO PRESENT</b> Transferable to UC, CSU Recommendation: ENGL 52 or ENGL 72 or ESL 152 and READ 54 or READ 97 or equivalent with grades of "C" or higher or "Pass".					28018	3.0 HRS ARR 3.0 HRS ARR	(OL) (OL)	Phelps,,J Phelps,,J	ONLINE ONLINE
26175	3.0 HRS ARR	(OL)	Mac Devitt,J	ONLINE	<b>ART 112 - 3.0 UNITS LIFE DRAWING</b> Transferable to UC, CSU (CAN ART 24) Prerequisite: ART 110 or equivalent with a grade of "C" or higher or "Pass".				
<b>ART 104 - 3.0 UNITS AFRICAN ART HISTORY</b> Transferable to UC, CSU Recommendation: ENGL 52, or ENGL 72 or ESL 152 and READ 54 or READ 97 or equivalent with grades of "C" or higher or "Pass".					20067	9:00-10:00AM 10:00-11:50AM	MW MW	Najarian,H Najarian,H	REMOTE REMOTE
30046	3.0 HRS ARR	(OL)	Robertson,C	ONLINE	Life Drawing- MW- Synchronous for three hours of instruction, twice a week. Please note that due to the nature of the course and sensitive subject matter, the course offers live model imagery for the curriculum, which will only be shared with the students during the hours of instruction. Students must attend a mandatory Zoom meeting on the first scheduled day of class. Students have an optional second day of the week for office hours or discussions of the assigned course work.				
<b>ART 105A - 3.0 UNITS THE ARTS OF LATIN AMERICA AND THE CARIBBEAN: PRE-COLUMBIAN</b> Transferable to UC, CSU Recommendation: ENGL 52 or ENGL 72 or ESL 152 and READ 54 or READ 97 or equivalent with grades of "C" or higher or "Pass".					20628	6:00-7:00PM 7:00-8:50PM	MW MW	Martinez,E Martinez,E	REMOTE REMOTE
27402	3.0 HRS ARR	(OL)	Mac Devitt,J	ONLINE	Life Drawing- MW- Synchronous for three hours of instruction, twice a week. Please note that due to the nature of the course and sensitive subject matter, the course offers live model imagery for the curriculum, which will only be shared with the students during the hours of instruction. Students must attend a mandatory Zoom meeting on the first scheduled day of class. Students have an optional second day of the week for office hours or discussions of the assigned course work.				
<b>ART 108 - 3.0 UNITS BLACK IMAGES IN POPULAR CULTURE</b> Transferable to UC, CSU Recommendation: ENGL 52 and READ 54 or equivalent with grades of "C" or higher or "Pass" is strongly recommended.					21706	1:00-2:00PM 2:00-3:50PM	MW MW	Graziano,A Graziano,A	REMOTE REMOTE
30578	3.0 HRS ARR	(OL)	Goldsmith,M	ONLINE	Life Drawing- MW- Synchronous for three hours of instruction, twice a week. Please note that due to the nature of the course and sensitive subject matter, the course offers live model imagery for the curriculum, which will only be shared with the students during the hours of instruction. Students must attend a mandatory Zoom meeting on the first scheduled day of class. Students have an optional second day of the week for office hours or discussions of the assigned course work.				
<b>ART 110 - 3.0 UNITS FREEHAND DRAWING</b> Transferable to UC, CSU (CAN ART 8)					20064	8:00-9:00AM 9:00-10:50AM	TTh TTh	Tran,B Tran,B	REMOTE REMOTE
20065	9:00-10:50AM 10:00-11:50AM	MW MW	Bersaglieri,A Bersaglieri,A	REMOTE REMOTE	Asynchronous/Hybrid classes meet the first day of each week for a mandatory Zoom meeting. Students have an optional second day of the week for office hours or discussions of the assigned course work.				
20066	1:00-2:00PM 2:00-3:50PM	TTh TTh	Graziano,A Graziano,A	REMOTE REMOTE	Asynchronous/Hybrid classes meet the first day of each week for a mandatory Zoom meeting. Students have an optional second day of the week for office hours or discussions of the assigned course work.				
24007	6:00-7:00PM 7:00-8:50PM	TTh TTh	Rolon,A Rolon,A	REMOTE REMOTE	Asynchronous/Hybrid classes meet the first day of each week for a mandatory Zoom meeting. Students have an optional second day of the week for office hours or discussions of the assigned course work.				
20627	6:00-7:00PM 7:00-8:50PM	MW MW	Kuo,A Kuo,A	REMOTE REMOTE	Asynchronous/Hybrid classes meet the first day of each week for a mandatory Zoom meeting. Students have an optional second day of the week for office hours or discussions of the assigned course work.				
24349	1:00-2:00PM 2:00-3:50PM	MW MW	Teran,S Teran,S	REMOTE REMOTE	Asynchronous/Hybrid classes meet the first day of each week for a mandatory Zoom meeting. Students have an optional second day of the week for office hours or discussions of the assigned course work.				
24351	9:00-11:00AM 11:00-2:50PM	F F	Minear,S Minear,S	REMOTE REMOTE	Asynchronous/Hybrid classes meet the first day of each week for a mandatory Zoom meeting. Students have an optional second day of the week for office hours or discussions of the assigned course work.				
26837	6:00-7:00PM 7:00-8:50PM	MW MW	Acuna,R Acuna,R	REMOTE REMOTE	Asynchronous/Hybrid classes meet the first day of each week for a mandatory Zoom meeting. Students have an optional second day of the week for office hours or discussions of the assigned course work.				
<b>ART 114 - 3.0 UNITS STORYBOARDING AND ANIMATION PRINCIPLES FOR FILM</b> Transferable to CSU					21858	2.0 HRS ARR + 4.0 HRS ARR	(OL) (OL)	Hirohama,S Hirohama,S	ONLINE ONLINE
30636	2.0 HRS ARR + 4.0 HRS ARR	(OL) (OL)	Hirohama,S Hirohama,S	ONLINE ONLINE	Asynchronous/Hybrid classes meet the first day of each week for a mandatory Zoom meeting. Students have an optional second day of the week for office hours or discussions of the assigned course work.				
<b>ART 115L - 1.0 UNIT PRINTMAKING LAB</b> Transferable to UC, CSU Corequisite: Concurrent enrollment in ART 116 or ART 117					20629	5:30-6:50PM	MW	Teran,S	REMOTE
Asynchronous/Hybrid classes meet the first day of each week for a mandatory Zoom meeting. Students have an optional second day of the week for office hours or discussions of the assigned course work.					<b>ART 116 - 3.0 UNITS BEGINNING PRINTMAKING</b> Transferable to UC, CSU (CAN ART 20) NOTE: a material fee of \$35.00 is required for ART 116				
20630	7:00-8:00PM 8:00-9:50PM	MW MW	Teran,S Teran,S	REMOTE REMOTE	Asynchronous/Hybrid classes meet the first day of each week for a mandatory Zoom meeting. Students have an optional second day of the week for office hours or discussions of the assigned course work.				
<b>ART 117 - 3.0 UNITS INTERMEDIATE PRINTMAKING</b> Transferable to UC, CSU Prerequisite: ART 116 or equivalent with a grade of "C" or higher "Pass". NOTE: a material fee of \$35.00 is required for ART 117					20631	7:00-8:00PM 8:00-9:50PM	MW MW	Teran,S Teran,S	REMOTE REMOTE
Asynchronous/Hybrid classes meet the first day of each week for a mandatory Zoom meeting. Students have an optional second day of the week for office hours or discussions of the assigned course work.									

If a class displays as **REMOTE** in the schedule, students will be expected to log into the class at a specified day/time (e.g., MW 8-9:15am). If the class displays as **ONLINE** in the schedule, students are permitted to log into the class whenever they are available to complete coursework by the established deadlines.

Students not in attendance or late for the first class meeting are subject to drop.

Class#	Time	Day	Instructor	Room	Class#	Time	Day	Instructor	Room
<b>ART 118 - 3.0 UNITS HISTORY OF WOMEN IN VISUAL ARTS</b> Transferable to UC, CSU Recommendation: ENGL 52 or ENGL 72 or ESL 152 or equivalent with a grade of "C" or higher or "Pass" or completion of the English assessment/placement process with a score eligible for ENGL 100 or ENGL 100S and READ 54 or READ 97 or READ 102 or equivalent with a grade of "C" or higher or "Pass" or completion of the Reading assessment/placement process with a score of "Reading Exempt."					20073	1:00-2:00PM 2:00-3:50PM	TTh TTh	Najarian,H Najarian,H	REMOTE REMOTE
29720	3.6 HRS ARR	(OL)	Vitela,L	ONLINE	<b>ART 136 - 3.0 UNITS PAINTING FOR ART MAJORS</b> Transferable to UC, CSU Prerequisite: ART 110 or equivalent with a grade of "C" or higher or "Pass". Recommendation: ART 120 or equivalent with a grade of "C" or higher or "Pass". Asynchronous/Hybrid classes meet the first day of each week for a mandatory Zoom meeting. Students have an optional second day of the week for office hours or discussions of the assigned course work.				
<b>ART 120 - 3.0 UNITS TWO-DIMENSIONAL DESIGN</b> Transferable to UC, CSU (CAN ART 14) Asynchronous/Hybrid classes meet the first day of each week for a mandatory Zoom meeting. Students have an optional second day of the week for office hours or discussions of the assigned course work.					20074	8:00-9:00AM 9:00-10:50AM	TTh TTh	Graziano,A Graziano,A	REMOTE REMOTE
20068	12:30-1:30PM 1:30-3:20PM	TTh TTh	Teran,S Teran,S	REMOTE REMOTE	20075	1:00-2:00PM 2:00-3:50PM	TTh TTh	Najarian,H Najarian,H	REMOTE REMOTE
20632	6:00-7:00PM 7:00-8:50PM	TTh TTh	Lopez,R Lopez,R	REMOTE REMOTE	<b>ART 150 - 3.0 UNITS INTRODUCTION TO CERAMICS</b> Transferable to UC, CSU (CAN ART 6) NOTE: a material fee of \$10.00 is required for ART 150 Note: Asynchronous/Hybrid classes meet the first day of each week for a mandatory Zoom meeting.				
<b>ART 121 - 3.0 UNITS THREE-DIMENSIONAL DESIGN</b> Transferable to UC, CSU (CAN ART 16) Prerequisite: ART 120 or equivalent with a grade of "C" or higher or "Pass". NOTE: a material fee of \$25.00 is required for ART 121 Note: Asynchronous/Hybrid classes meet the first day of each week for a mandatory Zoom meeting.					24357	2.0 HRS ARR + 4.0 HRS ARR	(OL) (OL)	Weiss,T Weiss,T	ONLINE ONLINE
20069	12:30-1:30PM 1:30-3:20PM	MW MW	Weiss,T Weiss,T	REMOTE REMOTE	23419	2.0 HRS ARR + 4.0 HRS ARR	(OL) (OL)	STAFF STAFF	ONLINE ONLINE
<b>ART 122 - 3.0 UNITS COLOR THEORY</b> Transferable to UC, CSU Prerequisite: Completion of Art 110 or Art 120 or equivalent with a grade of "C" or higher or "Pass".					20076	2.0 HRS ARR + 4.0 HRS ARR	(OL) (OL)	Gonzalez,A Gonzalez,A	ONLINE ONLINE
27243	1:00-2:00PM 2:00-3:50PM	MW MW	Najarian,H Najarian,H	REMOTE REMOTE	<b>ART 182A - 3.0 UNITS LETTERING AND TYPOGRAPHY</b> Transferable to CSU NOTE: a material fee of \$10.00 is required for ART 182A Note: Students must have access to: A computer that can run Adobe software. System requirements are here: <a href="https://helpx.adobe.com/creative-cloud/system-requirements.html">https://helpx.adobe.com/creative-cloud/system-requirements.html</a> Adobe Creative Cloud Subscription. Best student price here: <a href="https://foundationccc.org/CollegeBuys">https://foundationccc.org/CollegeBuys</a> A highspeed Internet connection.				
<b>ART 124 - 3.0 UNITS INTRODUCTION TO MEDIA STUDIES</b> Transferable to CSU Recommendation: ENGL 52 or ENGL 72 or ESL 152 or equivalent with a grade of "C" or higher or "Pass" or completion of the English assessment/placement process with a score eligible for ENGL 100 or ENGL 100S and READ 54 or READ 97 or equivalent with a grade of "C" or higher or "Pass" or completion of the Reading assessment/placement process with a score of "Reading Exempt."					20078	2.0 HRS ARR + 4.0 HRS ARR	(OL) (OL)	Gill,S Gill,S	ONLINE ONLINE
30047	6.0 HRS ARR	(OL)	Trager,J	ONLINE	<b>ART 186 - 3.0 UNITS COMPUTER GRAPHICS WITH ADOBE ILLUSTRATOR</b> Transferable to CSU NOTE: a material fee of \$10.00 is required for ART 186 Note: Students must have access to: A computer that can run Adobe software. System requirements are here: <a href="https://helpx.adobe.com/creative-cloud/system-requirements.html">https://helpx.adobe.com/creative-cloud/system-requirements.html</a> Adobe Creative Cloud Subscription. Best student price here: <a href="https://foundationccc.org/CollegeBuys">https://foundationccc.org/CollegeBuys</a> A highspeed Internet connection.				
<b>ART 130A - 3.0 UNITS FUNDAMENTALS OF PAINTING</b> Transferable to UC, CSU (CAN ART 10) Prerequisite: ART 110 or equivalent with a grade of "C" or higher or "Pass". Recommendation: ART 120 or equivalent with a grade of "C" or higher or "Pass".					22426	2.0 HRS ARR + 4.0 HRS ARR	(OL) (OL)	Barrett,B Barrett,B	ONLINE ONLINE
20070	8:00-9:00AM 9:00-10:50AM	TTh TTh	Graziano,A Graziano,A	REMOTE REMOTE	<b>ART 188 - 3.0 UNITS DESIGN FOR DIGITAL PUBLISHING</b> Transferable to CSU NOTE: a material fee of \$10.00 is required for ART 188 Note: Students must have access to: A computer that can run Adobe software. System requirements are here: <a href="https://helpx.adobe.com/creative-cloud/system-requirements.html">https://helpx.adobe.com/creative-cloud/system-requirements.html</a> Adobe Creative Cloud Subscription. Best student price here: <a href="https://foundationccc.org/CollegeBuys">https://foundationccc.org/CollegeBuys</a> A highspeed Internet connection.				
20071	1:00-2:00PM 2:00-3:50PM	TTh TTh	Najarian,H Najarian,H	REMOTE REMOTE	27241	2.0 HRS ARR + 4.0 HRS ARR	(OL) (OL)	Jankowski,J Jankowski,J	ONLINE ONLINE
<b>ART 130B - 3.0 UNITS FUNDAMENTALS OF PAINTING</b> Transferable to UC, CSU Prerequisite: ART 130A or equivalent with a grade of "C" or higher or "Pass".					22107	2.0 HRS ARR + 4.0 HRS ARR	(OL) (OL)	Barrett,B Barrett,B	ONLINE ONLINE
20072	8:00-9:00AM 9:00-10:50AM	TTh TTh	Graziano,A Graziano,A	REMOTE REMOTE	Asynchronous/Hybrid classes meet the first day of each week for a mandatory Zoom meeting. Students have an optional second day of the week for office hours or discussions of the assigned course work.				

If a class displays as **REMOTE** in the schedule, students will be expected to log into the class at a specified day/time (e.g., MW 8-9:15am). If the class displays as **ONLINE** in the schedule, students are permitted to log into the class whenever they are available to complete coursework by the established deadlines.

Students not in attendance or late for the first class meeting are subject to drop.



Class#	Time	Day	Instructor	Room	Class#	Time	Day	Instructor	Room
<b>ART 192 - 3.0 UNITS PHOTOSHOP/DIGITAL IMAGING</b> Transferable to CSU NOTE: a material fee of \$10.00 is required for ART 192									
20082	2.0 HRS ARR	(OL)	Wilson,C	ONLINE					
	+ 4.0 HRS ARR	(OL)	Wilson,C	ONLINE					
Note: This is an ONLINE course – all class instruction completed online. Please check Canvas or instructor website for more information: <a href="http://www.art192.com">http://www.art192.com</a> for online orientation information and directions for completion (instructor e-mail address: <a href="mailto:cw@art192.com">cw@art192.com</a> )									
20083	2.0 HRS ARR	(OL)	Miller,K	ONLINE					
	+ 4.0 HRS ARR	(OL)	Miller,K	ONLINE					
A computer that can run Adobe software. System requirements are here: <a href="https://helpx.adobe.com/creative-cloud/system-requirements.html">https://helpx.adobe.com/creative-cloud/system-requirements.html</a> Adobe Creative Cloud Subscription. Best student price here: <a href="https://foundationccc.org/CollegeBuys">https://foundationccc.org/CollegeBuys</a> A highspeed Internet connection.									
26180	2.0 HRS ARR	(OL)	Wilson,C	ONLINE					
	+ 4.0 HRS ARR	(OL)	Wilson,C	ONLINE					
A computer that can run Adobe software. System requirements are here: <a href="https://helpx.adobe.com/creative-cloud/system-requirements.html">https://helpx.adobe.com/creative-cloud/system-requirements.html</a> Adobe Creative Cloud Subscription. Best student price here: <a href="https://foundationccc.org/CollegeBuys">https://foundationccc.org/CollegeBuys</a> A highspeed Internet connection.									
Note: This is an ONLINE course – all class instruction completed online. Please check Canvas or instructor website for more information: <a href="http://www.art192.com">http://www.art192.com</a> for online orientation information and directions for completion (instructor e-mail address: <a href="mailto:cw@art192.com">cw@art192.com</a> )									
27032	2.0 HRS ARR	(OL)	Miller,K	ONLINE					
	+ 4.0 HRS ARR	(OL)	Miller,K	ONLINE					
A computer that can run Adobe software. System requirements are here: <a href="https://helpx.adobe.com/creative-cloud/system-requirements.html">https://helpx.adobe.com/creative-cloud/system-requirements.html</a> Adobe Creative Cloud Subscription. Best student price here: <a href="https://foundationccc.org/CollegeBuys">https://foundationccc.org/CollegeBuys</a> A highspeed Internet connection.									
<b>ART 193 - 3.0 UNITS MOTION PICTURE EDITING</b> Transferable to CSU									
30582	2.4 HRS ARR	(OL)	Wilson,C	ONLINE					
	+ 4.8 HRS ARR	(OL)	Wilson,C	ONLINE					
Class# 30582 meets 08/18/2020-11/24/2020 Note: This is an ONLINE course – all instruction completed online. Please visit instructor website for more information: <a href="http://www.art193.com">http://www.art193.com</a> or check Canvas for Online Orientation information and directions for completion (Instructor e-mail address: <a href="mailto:HYPERLINKmailto:cw@art192.com">HYPERLINK "mailto:cw@art192.com" cw@art192.com</a> )									
<b>ART 194A - 3.0 UNITS ADVANCED FINAL CUT PRO</b> Transferable to CSU									
30584	2.4 HRS ARR	(OL)	Wilson,C	ONLINE					
	+ 4.8 HRS ARR	(OL)	Wilson,C	ONLINE					
Class# 30584 meets 08/18/2020-11/24/2020 Note: This is an ONLINE course – all instruction completed online. Please visit instructor website for more information: <a href="http://www.art193.com">http://www.art193.com</a> or check Canvas for Online Orientation information and directions for completion (Instructor e-mail address: <a href="mailto:HYPERLINKmailto:cw@art192.com">HYPERLINK "mailto:cw@art192.com" cw@art192.com</a> )									
<b>ART 195 - 3.0 UNITS 3D MODELING FOR ANIMATION</b> Transferable to CSU NOTE: a material fee of \$10.00 is required for ART 195									
26840	2.0 HRS ARR	(OL)	Miller,K	ONLINE					
	+ 4.0 HRS ARR	(OL)	Miller,K	ONLINE					
Note: This is an ONLINE course – all instruction completed online. Please visit instructor website for more information: <a href="http://www.art193.com">http://www.art193.com</a> or check Canvas for Online Orientation information and directions for completion (Instructor e-mail address: <a href="mailto:HYPERLINKmailto:cw@art192.com">HYPERLINK "mailto:cw@art192.com" cw@art192.com</a> )									
<b>ART 196 - 3.0 UNITS WEB DESIGN WITH FLASH AND DREAMWEAVER</b> Transferable to CSU Recommendation: CIS 205 or equivalent with a grade of "C" or higher or "Pass". NOTE: a material fee of \$10.00 is required for ART 196									
20085	2.0 HRS ARR	(OL)	Miller,K	ONLINE					
	+ 4.0 HRS ARR	(OL)	Miller,K	ONLINE					
Note: This is an ONLINE course – all instruction completed online. Please visit instructor website for more information: <a href="http://www.art193.com">http://www.art193.com</a> or check Canvas for Online Orientation information and directions for completion (Instructor e-mail address: <a href="mailto:HYPERLINKmailto:cw@art192.com">HYPERLINK "mailto:cw@art192.com" cw@art192.com</a> )									
<b>ART 207 - 3.0 UNITS WOMEN AND MEDIA</b> Transferable to UC, CSU Prerequisite: ENGL 52 or ENGL 72 or ESL 152 or equivalent with a grade of "C" or higher, or "Pass," or completion of the English assessment/placement process with eligibility for ENGL 100 or ENGL 100S.									
29079	6.0 HRS ARR	(OL)	Trager,J	ONLINE					
Class# 29079 meets 10/20/2020-12/17/2020									
<b>ART 213 - 3.0 UNITS INTERMEDIATE LIFE DRAWING</b> Transferable to UC, CSU Prerequisite: ART 112 or equivalent with a grade of "C" or higher or "Pass".									
20086	9:00-10:00AM	MW	Najarian,H	REMOTE					
	10:00-11:50AM	MW	Najarian,H	REMOTE					
Life Drawing- MW- Synchronous for three hours of instruction, twice a week. Please note that due to the nature of the course and sensitive subject matter, the course offers live model imagery for the curriculum, which will only be shared with the students during the hours of instruction. Students must attend a mandatory Zoom meeting on the first scheduled day of class. Students have an optional second day of the week for office hours or discussions of the assigned course work.									
20636	6:00-7:00PM	MW	Martinez,E	REMOTE					
	7:00-8:50PM	MW	Martinez,E	REMOTE					
Life Drawing- MW- Synchronous for three hours of instruction, twice a week. Please note that due to the nature of the course and sensitive subject matter, the course offers live model imagery for the curriculum, which will only be shared with the students during the hours of instruction. Students must attend a mandatory Zoom meeting on the first scheduled day of class. Students have an optional second day of the week for office hours or discussions of the assigned course work.									
21708	1:00-2:00PM	MW	Graziano,A	REMOTE					
	2:00-3:50PM	MW	Graziano,A	REMOTE					
Life Drawing- MW- Synchronous for three hours of instruction, twice a week. Please note that due to the nature of the course and sensitive subject matter, the course offers live model imagery for the curriculum, which will only be shared with the students during the hours of instruction. Students must attend a mandatory Zoom meeting on the first scheduled day of class. Students have an optional second day of the week for office hours or discussions of the assigned course work.									
<b>ART 214 - 3.0 UNITS SPECIAL STUDIES IN LIFE DRAWING</b> Transferable to UC, CSU Prerequisite: ART 213 or equivalent with a grade of "C" or higher or "Pass".									
21710	1:00-2:00PM	MW	Graziano,A	REMOTE					
	2:00-3:50PM	MW	Graziano,A	REMOTE					
Life Drawing- MW- Synchronous for three hours of instruction, twice a week. Please note that due to the nature of the course and sensitive subject matter, the course offers live model imagery for the curriculum, which will only be shared with the students during the hours of instruction. Students must attend a mandatory Zoom meeting on the first scheduled day of class. Students have an optional second day of the week for office hours or discussions of the assigned course work.									
21762	6:00-7:00PM	MW	Martinez,E	REMOTE					
	7:00-8:50PM	MW	Martinez,E	REMOTE					
Life Drawing- MW- Synchronous for three hours of instruction, twice a week. Please note that due to the nature of the course and sensitive subject matter, the course offers live model imagery for the curriculum, which will only be shared with the students during the hours of instruction. Students must attend a mandatory Zoom meeting on the first scheduled day of class. Students have an optional second day of the week for office hours or discussions of the assigned course work.									
21856	9:00-10:00AM	MW	Najarian,H	REMOTE					
	10:00-11:50AM	MW	Najarian,H	REMOTE					
Life Drawing- MW- Synchronous for three hours of instruction, twice a week. Please note that due to the nature of the course and sensitive subject matter, the course offers live model imagery for the curriculum, which will only be shared with the students during the hours of instruction. Students must attend a mandatory Zoom meeting on the first scheduled day of class. Students have an optional second day of the week for office hours or discussions of the assigned course work.									
<b>ART 217L - 1.0 UNIT ADVANCED SCREENPRINTING/ADVANCED ETCHING LAB</b> Transferable to CSU Corequisite: Concurrent enrollment in ART 218 or ART 219.									
21379	5:30-6:50PM	MW	Teran,S	REMOTE					

If a class displays as **REMOTE** in the schedule, students will be expected to log into the class at a specified day/time (e.g., MW 8-9:15am). If the class displays as **ONLINE** in the schedule, students are permitted to log into the class whenever they are available to complete coursework by the established deadlines.

Students not in attendance or late for the first class meeting are subject to drop.

Class#	Time	Day	Instructor	Room	Class#	Time	Day	Instructor	Room
<b>ART 218 - 3.0 UNITS SCREENPRINTING</b> Transferable to UC, CSU Prerequisite: ART 117 or equivalent with a grade of "C" or higher or "Pass". NOTE: a material fee of \$35.00 is required for ART 218									
20637	7:00-8:00PM	MW	Teran,S	REMOTE					
	8:00-9:50PM	MW	Teran,S	REMOTE					
<b>ART 219 - 3.0 UNITS ADVANCED ETCHING</b> Transferable to UC, CSU Prerequisite: ART 117 or equivalent with a grade of "C" or higher or "Pass". NOTE: a material fee of \$35.00 is required for ART 219									
22027	7:00-8:00PM	MW	Teran,S	REMOTE					
	8:00-9:50PM	MW	Teran,S	REMOTE					
<b>ART 231 - 3.0 UNITS INTERMEDIATE PAINTING</b> Transferable to UC, CSU Prerequisite: ART 130B or equivalent with a grade of "C" or higher or "Pass". 8:00-9:00AM TTh Graziano,A REMOTE 9:00-10:50AM TTh Graziano,A REMOTE Asynchronous/Hybrid classes meet the first day of each week for a mandatory Zoom meeting. Students have an optional second day of the week for office hours or discussions of the assigned course work.									
21714	1:00-2:00PM	TTh	Graziano,A	REMOTE					
	2:00-3:50PM	TTh	Graziano,A	REMOTE					
20087	1:00-2:00PM	TTh	Graziano,A	REMOTE					
	2:00-3:50PM	TTh	Graziano,A	REMOTE					
Asynchronous/Hybrid classes meet the first day of each week for a mandatory Zoom meeting. Students have an optional second day of the week for office hours or discussions of the assigned course work.									
<b>ASTRONOMY</b>									
<b>ASTR 102 - 3.0 UNITS INTRODUCTORY ASTRONOMY: STARS AND THE UNIVERSE</b> Transferable to UC, CSU									
30325	3.0 HRS ARR	(OL)	Szabo,T	ONLINE					
Note Orientation: All class information will be available online via Canvas. Email address tszabo@cerritos.edu									
22659	4:00-5:15PM	MW	Szabo,T	REMOTE					
22258	4:00-5:15PM	TTh	Szabo,T	REMOTE					
25395	12:30-1:45PM	MW	Szabo,T	REMOTE					
26924	2:00-3:15PM	TTh	Szabo,T	REMOTE					
<b>ASTR 103 - 3.0 UNITS INTRODUCTORY ASTRONOMY: THE SOLAR SYSTEM</b> Transferable to UC, CSU									
22796	3.0 HRS ARR	(OL)	McLarty-Schroeder,J	ONLINE					
20088	3.0 HRS ARR	(OL)	McLarty-Schroeder,J	ONLINE					
Note Orientation: All class information will be available online via Canvas. Email address jmclarty@cerritos.edu									
21253	3.0 HRS ARR	(OL)	McLarty-Schroeder,J	ONLINE					
21254	3.0 HRS ARR	(OL)	McLarty-Schroeder,J	ONLINE					
Note Orientation: All class information will be available online via Canvas. Email address jmclarty@cerritos.edu									
22394	3.0 HRS ARR	(OL)	McLarty-Schroeder,J	ONLINE					
Note Orientation: All class information will be available online via Canvas. Email address jmclarty@cerritos.edu									
<b>ASTR 104 - 3.0 UNITS LIFE IN THE UNIVERSE</b> Transferable to UC, CSU									
20640	3.0 HRS ARR	(OL)	McLarty-Schroeder,J	ONLINE					
<b>ASTR 105L - 1.0 UNIT OBSERVATIONAL ASTRONOMY</b> Transferable to UC, CSU Prerequisite: ASTR 101 or ASTR 102 or ASTR 103 or ASTR 104 or ASTR 106 or equivalent with a grade of "C" or higher or "Pass" or concurrent enrollment.									
20641	7:00-9:50PM	Th	Szabo,T	REMOTE					
20642	7:00-9:50PM	T	Szabo,T	REMOTE					
<b>ATHLETICS</b>									
<b>ATH 201LB - 2.0 UNITS BASEBALL, MEN, OFF SEASON INTERCOLLEGIATE</b> Transferable to UC, CSU									
24670	1:00-3:50PM	MW	Buttler Jr.,V	REMOTE					
<b>ATH 202L - 3.0 UNITS BASKETBALL, MEN</b> Transferable to UC, CSU									
24671	3:00-4:50PM	MTWThF	May,R	REMOTE					
<b>ATH 204L - 1.5 UNITS BASKETBALL, WOMEN</b> Transferable to UC, CSU									
24673	1:00-2:50PM	MTWThF	Kozlowski,T	REMOTE	Class# 24673 meets 10/19/2020-12/18/2020				
<b>ATH 205LA - 1.0 UNIT BASKETBALL, WOMEN, OFF SEASON INTERCOLLEGIATE</b> Transferable to UC, CSU									
24674	1:00-2:20PM	MTWTh	Kozlowski,T	REMOTE	Class# 24674 meets 08/17/2020-10/15/2020				
<b>ATH 206L - 3.0 UNITS CROSS COUNTRY, MEN</b> Transferable to UC, CSU									
24675	9:00-10:50AM	F	Richardson,C	REMOTE					
	12:00-1:50PM	MTWTh	Richardson,C	REMOTE					
<b>ATH 208L - 3.0 UNITS CROSS COUNTRY, WOMEN</b> Transferable to UC, CSU									
24676	1:00-2:50PM	MTWTh	Richardson,C	REMOTE					
<b>ATH 210L - 3.0 UNITS FOOTBALL, MEN</b> Transferable to UC, CSU									
24677	3:45-5:35PM	MTWF	Garcia,P	REMOTE					
	7:00-8:50PM	Th	Gnodle,D	REMOTE					
26226	3:45-5:35PM	MTWF	Caines,T	REMOTE					
	7:00-8:50PM	Th	Caines,T	REMOTE					
26227	3:45-5:35PM	MTWF	Grosfeld,S	REMOTE					
	7:00-8:50PM	Th	Grosfeld,S	REMOTE					
<b>ATH 212L - 3.0 UNITS SOCCER, MEN</b> Transferable to UC, CSU									
24678	2:00-3:50PM	MTWThF	Artiaga,B	REMOTE					
<b>ATH 214L - 3.0 UNITS SOCCER, WOMEN</b> Transferable to UC, CSU									
24679	7:00-8:20AM	Sat	Gonzalez,R	REMOTE					
	8:00-9:20AM	MWTh	Gonzalez,R	REMOTE					
	3:15-4:50PM	TF	Gonzalez,R	REMOTE					
<b>ATH 217LC - 3.0 UNITS SOFTBALL, WOMEN, OFF SEASON INTERCOLLEGIATE</b> Transferable to UC, CSU									
24680	1:00-3:05PM	MTWTh	Murray,K	REMOTE					
<b>ATH 219LC - 3.0 UNITS SWIMMING, MEN, OFF SEASON INTERCOLLEGIATE</b> Transferable to UC, CSU									
24681	7:00-10:00AM	F	Abing,J	REMOTE					
	9:00-9:50AM	MW	Abing,J	REMOTE					
	4:30-6:20PM	TTh	Abing,J	REMOTE					
<b>ATH 221LA - 1.0 UNIT SWIMMING, WOMEN, OFF SEASON INTERCOLLEGIATE</b> Transferable to UC, CSU									
30215	6:00-6:50AM	TWTh	Macias,S	REMOTE					
<b>ATH 223LA - 1.0 UNIT TENNIS, MEN, OFF SEASON INTERCOLLEGIATE</b> Transferable to UC, CSU									
30216	12:30-1:45PM	TTh	Caldaron,Q	REMOTE					
<b>ATH 225LA - 1.0 UNIT TENNIS, WOMEN, OFF SEASON INTERCOLLEGIATE</b> Transferable to UC, CSU									
30217	11:00-12:15PM	TTh	Caldaron,Q	REMOTE					

If a class displays as **REMOTE** in the schedule, students will be expected to log into the class at a specified day/time (e.g., MW 8-9:15am). If the class displays as **ONLINE** in the schedule, students are permitted to log into the class whenever they are available to complete coursework by the established deadlines.

Students not in attendance or late for the first class meeting are subject to drop.

Class#	Time	Day	Instructor	Room	Class#	Time	Day	Instructor	Room
<b>ATH 227LC - 3.0 UNITS TRACK AND FIELD, MEN, OFF SEASON INTERCOLLEGIATE</b>					<b>AB 52 - 4.5 UNITS STRUCTURAL DAMAGE REPAIR</b>				
Transferable to UC, CSU					Not Transferable				
25023	12:00-12:50PM	F	Richardson,C	REMOTE	Recommendation: AB 51 or AB 57 or equivalent with a grade of "C" or higher or "Pass".				
	2:00-3:50PM	MTWTh	Richardson,C	REMOTE	NOTE: a material fee of \$20.00 is required for AB 52				
<b>ATH 229LC - 3.0 UNITS TRACK AND FIELD, WOMEN, OFF SEASON INTERCOLLEGIATE</b>					30343	3.6 HRS ARR	(OL)	Chisum,A	ONLINE
Transferable to UC, CSU						<b>5:30-10:00PM</b>	<b>MW</b>	Chisum,A (HYBRID)	AT 60
25024	1:00-1:50PM	F	Richardson,C	REMOTE	The lab portion of this class will be a hybrid - partially on campus & partially online. The class will be divided into two groups. Each group will be on campus partially. You will be contacted by your instructor on which group you will be assigned to.				
	1:00-2:50PM	MTWTh	Richardson,C	REMOTE	Class# 30343 meets 09/08/2020-12/18/2020				
<b>ATH 230L - 3.0 UNITS VOLLEYBALL, WMEN</b>					<b>AB 53 - 4.5 UNITS STEERING, SUSPENSION AND POWERTRAIN DAMAGE</b>				
Transferable to UC, CSU					Not Transferable				
24687	7:00-8:50AM	MTWTh	Hemmerling,K	REMOTE	Recommendation: AB 51 or equivalent with a grade of "C" or higher or "Pass".				
<b>ATH 232L - 3.0 UNITS WATER POLO, MEN</b>					NOTE: a material fee of \$20.00 is required for AB 53				
Transferable to UC, CSU					27580	3.0 HRS ARR	(OL)	Ferre,C	ONLINE
24688	10:00-11:50AM	MW	Abing,J	REMOTE		7:00-11:00AM	TTh	Ferre,C (HYBRID)	AT 70
	10:00-12:50PM	F	Abing,J	REMOTE	The lab portion of this class will be a hybrid - partially on campus & partially online. The class will be divided into two groups. Each group will be on campus partially. You will be contacted by your instructor on which group you will be assigned to.				
	12:30-1:50PM	TTh	Abing,J	REMOTE	Class# 27580 meets 09/08/2020-12/18/2020				
<b>ATH 234L - 3.0 UNITS WATER POLO, WOMEN</b>					<b>AB 56 - 2.0 UNITS NON-STRUCTURAL AUTOMOTIVE WELDING</b>				
Transferable to UC, CSU					Not Transferable				
24689	7:00-8:50AM	MTWThF	Macias,S	REMOTE	29255	3.0 HRS ARR	(OL)	Chisum,A	ONLINE
<b>ATH 236L - 3.0 UNITS WRESTLING, MEN</b>						1:00- 5:00PM	TTh	Chisum,A (HYBRID)	AT 50
Transferable to UC, CSU					The lab portion of this class will be a hybrid - partially on campus & partially online. The class will be divided into two groups. Each group will be on campus partially. You will be contacted by your instructor on which group you will be assigned to.				
24690	4:00-6:20PM	MTWTh	Gould,E	REMOTE	Class# 29255 meets 10/19/2020-12/18/2020				
<b>ATH 237LC - 3.0 UNITS WRESTLING, MEN, OFF SEASON INTERCOLLEGIATE</b>					<b>AB 63 - 4.5 UNITS PRODUCTION REFINISHING</b>				
Transferable to UC, CSU					Not Transferable				
30218	6:00-8:50PM	TWTh	STAFF	REMOTE	Recommendation: AB 61 or AB 62 or equivalent with a grade of "C" or higher or "Pass".				
<b>ATH 241 - 2.0 UNITS CHEERLEADING, OFF-SEASON</b>					NOTE: a material fee of \$20.00 is required for AB 63				
Transferable to UC, CSU					30600	3.0 HRS ARR	(OL)	Chisum,A	ONLINE
30219	7:00-9:50PM	MTWTh	Haley Peaslee,D	REMOTE		<b>6:00-10:00PM</b>	<b>TTh</b>	Chisum,A	AT 70

## AUTOMOTIVE COLLISION REPAIR & REFINISHING/AUTOBODY

<b>AB 51 - 4.5 UNITS NON-STRUCTURAL REPAIR</b>					<b>AB 66 - 2.5 UNITS LETTERING, STRIPING AND DESIGN</b>				
Not Transferable					Not Transferable				
NOTE: a material fee of \$20.00 is required for AB 51					Recommendation: AB 61 or equivalent with a grade of "C" or higher or "Pass" or appropriate work experience or concurrent enrollment.				
Please read the technical standards relevant to this department at <a href="http://cms.cerritos.edu/technology/standards.htm">http://cms.cerritos.edu/technology/standards.htm</a>					NOTE: a material fee of \$20.00 is required for AB 66				
29979	3.6 HRS ARR	(OL)	Ferre,C	ONLINE	28932	4.0 HRS ARR	(OL)	Ferre,C	ONLINE
	<b>5:30-10:30PM</b>	<b>MW</b>	Ferre,C (HYBRID)	AT 60		<b>6:00-10:00PM</b>	<b>MW</b>	Ferre,C (HYBRID)	AT 70
The lab portion of this class will be a hybrid - partially on campus & partially online. The class will be divided into two groups. Each group will be on campus partially. You will be contacted by your instructor on which group you will be assigned to.					The lab portion of this class will be a hybrid - partially on campus & partially online. The class will be divided into two groups. Each group will be on campus partially. You will be contacted by your instructor on which group you will be assigned to.				
Class# 29979 meets 09/08/2020-12/18/2020					Class# 28932 meets 08/17/2020-10/16/2020				
25682	3.6 HRS ARR	(OL)	Ferre,C	ONLINE	<b>AB 67 - 2.0 UNITS AUTOMOTIVE CUSTOM PAINTING</b>				
Please read the technical standards relevant to this department at <a href="http://cms.cerritos.edu/technology/standards.htm">http://cms.cerritos.edu/technology/standards.htm</a>					Not Transferable				
	8:00-12:30PM	MW	Ferre,C (HYBRID)	AT 60	Recommendation: AB 61 or AB 62 or equivalent with a grade "C" or higher or "Pass".				
The lab portion of this class will be a hybrid - partially on campus & partially online. The class will be divided into two groups. Each group will be on campus partially. You will be contacted by your instructor on which group you will be assigned to.					28934	2.0 HRS ARR	(OL)	Ferre,C	ONLINE
Class# 25682 meets 09/08/2020-12/18/2020						<b>5:00-10:00PM</b>	<b>MW</b>	Ferre,C (HYBRID)	AT 70
					The lab portion of this class will be a hybrid - partially on campus & partially online. The class will be divided into two groups. Each group will be on campus partially. You will be contacted by your instructor on which group you will be assigned to.				
					Class# 28934 meets 10/19/2020-12/18/2020				
					<b>AB 80 - 2.0 UNITS AUTOBODY CUSTOMER SERVICE</b>				
					Not Transferable				
					28936	4.0 HRS ARR	(OL)	Roehrs,K	ONLINE
					Class# 28936 meets 08/17/2020-10/16/2020				

If a class displays as **REMOTE** in the schedule, students will be expected to log into the class at a specified day/time (e.g., MW 8-9:15am). If the class displays as **ONLINE** in the schedule, students are permitted to log into the class whenever they are available to complete coursework by the established deadlines.

Students not in attendance or late for the first class meeting are subject to drop.

Class#	Time	Day	Instructor	Room	Class#	Time	Day	Instructor	Room
<b>AB 86 - 2.0 UNITS PRODUCTION MANAGEMENT</b> Not Transferable Recommendation: Work experience in the automotive collision repair industry. 28941 4.0 HRS ARR (OL) Roehrs,K ONLINE Class# 28941 meets 10/19/2020-12/18/2020					30603	3.0 HRS ARR <b>7:00- 9:00PM</b>	(OL) <b>MW</b>	Martin,E Martin,E	ONLINE AT 25
<b>AB 181 - 3.0 UNITS NON-STRUCTURAL DAMAGE ESTIMATING</b> Transferable to CSU Recommendation: Proficient in MS Windows Software application. NOTE: a material fee of \$5.00 is required for AB 181 29983 2.5 HRS ARR (OL) Tabares,R ONLINE + 1.5 HRS ARR (OL) Tabares,R ONLINE					23765	3.0 HRS ARR 8:00-1:50PM	(OL) F	Tedtaotao,D Tedtaotao,D	ONLINE AT 25
<b>AB 286 - 3.0 UNITS COMPUTERIZED SHOP MANAGEMENT</b> Transferable to CSU Prerequisite: AB 182 or AB 285 or equivalent with a grade of "C" or higher or "Pass", or concurrent enrollment or equivalent work experience. 29981 3.0 HRS ARR (OL) Corzo,R ONLINE + 1.0 HRS ARR (OL) Corzo,R ONLINE					21219	3.0 HRS ARR + 3.0 HRS AR	(OL) (OL)	Glick,L Glick,L	ONLINE ONLINE
<div style="background-color: #8B4513; color: white; padding: 10px; border: 1px solid black;"> <h2 style="margin: 0;">AUTOMOTIVE MECHANICAL REPAIR TECHNOLOGY</h2> </div>									
AUTO 54 - 4.0 UNITS INTRODUCTION TO ELECTRIC VEHICLE Not Transferable NOTE: a material fee of \$15.00 is required for AUTO 54 Please read the technical standards relevant to this department at <a href="http://cms.cerritos.edu/technology/standards.htm">http://cms.cerritos.edu/technology/standards.htm</a> 29443 3.0 HRS ARR (OL) Chavez,P ONLINE <b>6:30-9:20PM TTh</b> Chavez,P AT 25 The lab portion of this class will be a hybrid - partially on campus & partially online. The class will be divided into two groups. Each group will be on campus partially. You will be contacted by your instructor on which group you will be assigned to.					<b>AUTO 110 - 5.0 UNITS AUTOMOTIVE ENGINES</b> Transferable to CSU Recommendation: AUTO 100 or equivalent with a grade of "C" or higher or "Pass". NOTE: a material fee of \$15.00 is required for AUTO 110 21217 4.0 HRS ARR (OL) Vasilik,R ONLINE <b>6:30-10:20PM TTh</b> Vasilik,R AT 25 The lab portion of this class will be a hybrid - partially on campus & partially online. The class will be divided into two groups. Each group will be on campus partially. You will be contacted by your instructor on which group you will be assigned to.				
<b>AUTO 73 - 3.0 UNITS AUTOMOTIVE MECHANICAL REPAIR OCCUPATIONAL WORK EXPERIENCE</b> Not Transferable 30607 1.0 HRS ARR (OL) Vega,F ONLINE 20888 2.0 HRS ARR (OL) Glick,L ONLINE Class# 20888 meets 08/17/2020-10/16/2020 20889 2.0 HRS ARR (OL) Baron,T ONLINE Class# 20889 meets 08/17/2020-10/16/2020 20942 2.0 HRS ARR (OL) Bender,W ONLINE Class# 20942 meets 10/19/2020-12/18/2020 28947 2.0 HRS ARR (OL) Taylor,K ONLINE Please read the technical standards relevant to this department at <a href="http://cms.cerritos.edu/technology/standards.htm">http://cms.cerritos.edu/technology/standards.htm</a> Class# 28947 meets 10/19/2020-12/18/2020					<b>AUTO 120 - 5.0 UNITS AUTOMATIC TRANSMISSIONS AND TRANSAXLES</b> Transferable to CSU Recommendation: AUTO 100 or equivalent with a grade of Pass or "C" or higher, or appropriate work experience. NOTE: a material fee of \$15.00 is required for AUTO 120 27599 8:00-10:00 TTh Treadwell,G REMOTE 10:00-11:50AM TTh Treadwell,G REMOTE The lab portion of this class will be a hybrid - partially on campus & partially online. The class will be divided into two groups. Each group will be on campus partially. You will be contacted by your instructor on which group you will be assigned to.				
<b>AUTO 80 - 5.0 UNITS BUREAU OF AUTOMOTIVE REPAIR (BAR) ASE ALTERNATIVE COURSES FO</b> Not Transferable Recommendation: Appropriate work experience. NOTE: a material fee of \$100.00 is required for AUTO 80 29444 4.0 HRS ARR (OL) Baron,T ONLINE					<b>AUTO 121 - 6.0 UNITS DRIVETRAIN TRANSMISSIONS AND AXLES</b> Transferable to CSU Recommendation: AUTO 181 and AUTO 73/74 or equivalent with grades of Pass or "C" or higher. NOTE: a material fee of \$15.00 is required for AUTO 121 21398 10.0 HRS ARR (OL) Bender,W ONLINE + 10.0 HRS ARR (OL) Bender,W ONLINE Class# 21398 meets 08/17/2020-10/15/2020				
<b>AUTO 100 - 4.0 UNITS AUTOMOTIVE MAINTENANCE AND OPERATION</b> Transferable to CSU NOTE: a material fee of \$15.00 is required for AUTO 100 27035 3.0 HRS ARR (OL) Vega,F ONLINE 8:00-10:50AM W Vega,F AT 25 20091 3.0 HRS ARR (OL) Vega,F ONLINE 8:00-10:50AM Th Vega,F AT 25 The lab portion of this class will be a hybrid - partially on campus & partially online. The class will be divided into two groups. Each group will be on campus partially. You will be contacted by your instructor on which group you will be assigned to.					<b>AUTO 130 - 5.0 UNITS MANUAL DRIVETRAIN AND AXLES</b> Transferable to CSU Recommendation: AUTO 100 or equivalent with a grade of "C" or higher or "Pass". NOTE: a material fee of \$15.00 is required for AUTO 130 20645 4.0 HRS ARR (OL) Taylor,K ONLINE + 4.0 HRS ARR (OL) Taylor,K ONLINE				
					<b>AUTO 140 - 5.0 UNITS AUTOMOTIVE STEERING AND SUSPENSION</b> Transferable to CSU Recommendation: AUTO 100 or equivalent with a grade of "C" or higher or "Pass", or appropriate work experience. 27207 4.0 HRS ARR (OL) Borio,S ONLINE <b>6:30-9:30PM MW</b> Borio,S AT 45 The lab portion of this class will be a hybrid - partially on campus & partially online. The class will be divided into two groups. Each group will be on campus partially. You will be contacted by your instructor on which group you will be assigned to.				

If a class displays as **REMOTE** in the schedule, students will be expected to log into the class at a specified day/time (e.g., MW 8-9:15am). If the class displays as **ONLINE** in the schedule, students are permitted to log into the class whenever they are available to complete coursework by the established deadlines.

Students not in attendance or late for the first class meeting are subject to drop.

Class#	Time	Day	Instructor	Room	Class#	Time	Day	Instructor	Room
<b>AUTO 150 - 5.0 UNITS AUTOMOTIVE BRAKES</b> Transferable to CSU Recommendation: AUTO 100 or equivalent with a grade of "C" or higher or "Pass", or appropriate work experience. NOTE: a material fee of \$15.00 is required for AUTO 150					23827	8:00-10:50AM	T	Stieber,M	REMOTE
20992	4.0 HRS ARR	(OL)	Mulleary,J	ONLINE	20103	9:30-10:45AM	TTh	Stieber,M	REMOTE
	8:00-11:00AM	MW	Mulleary,J	AT 45	20107	3.0 HRS ARR	(OL)	Tydel,C	ONLINE
The lab portion of this class will be a hybrid - partially on campus & partially online. The class will be divided into two groups. Each group will be on campus partially. You will be contacted by your instructor on which group you will be assigned to.					20113	12:30-3:20PM	Th	Stieber,M	REMOTE
<b>AUTO 160 - 5.0 UNITS INTRODUCTION TO AUTOMOTIVE ELECTRICAL</b> Transferable to CSU Recommendation: AUTO 100 or appropriate work experience or equivalent with a grade of "C" or higher or "Pass". NOTE: a material fee of \$15.00 is required for AUTO 160					20105	3:30- 6:20PM	M	Takahashi,G	REMOTE
20644	4.0 HRS ARR	(OL)	Bender,W	ONLINE		+ 3.0 HRS ARR	(OL)	STAFF	ONLINE
	+ 4.0 HRS ARR	(OL)	Bender,W	ONLINE	20112	8:00-10:50AM	Th	Johnson,W	REMOTE
<b>AUTO 161 - 7.0 UNITS AUTOMOTIVE ELECTRICITY</b> Transferable to CSU Recommendation: AUTO 100 or AUTO 151 and AUTO 73/74 or equivalent with grades of Pass or "C" or higher. NOTE: a material fee of \$15.00 is required for AUTO 161						+ 3.0 HRS ARR	(OL)	STAFF	ONLINE
20899	12.0 HRS ARR	(OL)	Taylor,K	ONLINE		7:00- 9:50PM	T	Palmier,C	REMOTE
	+ 8.0 HRS ARR	(OL)	Taylor,K	ONLINE	20656	7:00- 9:50PM	W	Palmier,C	REMOTE
	Class# 20899 meets 08/17/2020-10/15/2020				20657	3.0 HRS ARR	(OL)	Chien,J	ONLINE
21292	12.0 HRS ARR	(OL)	Baron,T	ONLINE	20108	3:30- 6:20PM	T	Henderson,S	REMOTE
	+ 8.0 HRS ARR	(OL)	Baron,T	ONLINE	20114	3.0 HRS ARR	(OL)	Chien,J	ONLINE
	Class# 21292 meets 10/19/2020-12/17/2020					2:00- 3:15PM	TTh	Stieber,M	REMOTE
<b>AUTO 181 - 6.0 UNITS ELECTRONIC ENGINE MANAGEMENT SYSTEMS-CORPORATE</b> Transferable to CSU Recommendation: AUTO 100 and AUTO 73/74 or equivalent with grades of "C" or higher or "Pass". NOTE: a material fee of \$15.00 is required for AUTO 181					20109	9:00-11:50AM	W	Valcarcel,A	REMOTE
29996	6:30-8:00PM	F	Jacobo,C	REMOTE		2:00- 3:15PM	MW	Valcarcel,A	REMOTE
	6:30-9:40PM	TTh	Jacobo,C	AT 45	26868	9:00-11:50AM	M	Valcarcel,A	REMOTE
The lab portion of this class will be a hybrid - partially on campus & partially online. The class will be divided into two groups. Each group will be on campus partially. You will be contacted by your instructor on which group you will be assigned to.					<b>BIOL 200 - 5.0 UNITS PRINCIPLES OF BIOLOGY</b> Transferable to UC, CSU (CAN BIOL SEQ A) Prerequisite: CHEM 111 or equivalent with a grade of "C" or higher or "Pass" or concurrent enrollment and BIOL 120 or ZOOL 120 or BOT 120 or equivalent with a grade of "C" or higher or "Pass."				
30624	10.0 HRS ARR	(OL)	Mulleary,J	ONLINE	20115	11:00-12:15PM	W	Henderson,S	REMOTE
	+10.0 HRS ARR	(OL)	Mulleary,J (HYBRID)	AT 45		11:00-12:15PM	M	Henderson,S	REMOTE
	Class# 30624 meets 08/17/2020-10/16/2020				Meet in different room on Wednesday				
27603	10.0 HRS ARR	(OL)	Glick,L	ONLINE		1:00- 3:50PM	MW	Henderson,S	REMOTE
	+10.0 HRS ARR	(OL)	Glick,L	ONLINE	20117	8:00- 9:15AM	WF	Covill,M	REMOTE
	Class# 27603 meets 10/19/2020-12/17/2020				On Friday 11/13 & Friday 12/11, this class will meet from 11:00-5:00 pm for a field trip in lieu of normal class session. Dates subject to change based on permission to use sites.				
<b>BIOL 105 - 3.0 UNITS HUMANS AND THE ENVIRONMENT</b> Transferable to UC, CSU Recommendation: ENGL 52 or ENGL 72 or ESL 152 or equivalent with a grade of "C" or higher or "Pass" or completion of the English assessment/placement process with a score eligible for ENGL 100 or ENGL 100S.						10:00-12:50PM	WF	Covill,M	REMOTE
20101	12:30-1:45PM	MW	Valcarcel,A	REMOTE	<b>BIOL 201 - 5.0 UNITS PRINCIPLES OF BIOLOGY</b> Transferable to UC, CSU (CAN BIOL SEQ A) Prerequisite: CHEM 111 or equivalent with a grade of "C" or higher or "Pass" and (BIOL 120 or ZOOL 120 or BOT 120 ) or equivalent with a grade of "C" or higher or "Pass".				
23980	3.0 HRS ARR	(OL)	Behmer,E	ONLINE	20118	12:30-1:45PM	MW	Stieber,M	REMOTE
24294	12:30-1:45PM	TTh	Valcarcel,A	REMOTE		2:00- 4:50PM	MW	Stieber,M	REMOTE
29753	2:00-3:15PM	TTh	McNulty,S	REMOTE	29353	5:00- 6:15PM	Th	Martinez,I	REMOTE
<b>BIOL 115 - 3.0 UNITS MARINE BIOLOGY</b> Transferable to UC, CSU						5:00- 6:15PM	T	Martinez,I	REMOTE
26454	12:00-1:45PM	F	Reyes,J	REMOTE		7:00-9:50PM	TTh	Martinez,I	REMOTE
	2:00-4:50PM	F	Reyes,J	REMOTE	Meet in different room on Tuesday				
<b>BIOL 120 - 4.0 UNITS INTRODUCTION TO BIOLOGICAL SCIENCE</b> Transferable to UC, CSU (CAN BIOL 2) Prerequisite: ENGL 52 or ENGL 72 or ESL 152 or equivalent with a grade of "C" or higher or "Pass" or completion of the English assessment/placement process with a score eligible for ENGL 100 or ENGL 100S.					<b>BUSINESS ADMINISTRATION</b>				
20102	11:00-12:15PM	MW	Fang,Y	REMOTE	<b>BA 100 - 3.0 UNITS FUNDAMENTALS OF BUSINESS</b> Transferable to UC, CSU NOTE: a material fee of \$20.00 is required for BA 100				
If a class displays as <b>REMOTE</b> in the schedule, students will be expected to log into the class at a specified day/time (e.g., MW 8-9:15am). If the class displays as <b>ONLINE</b> in the schedule, students are permitted to log into the class whenever they are available to complete coursework by the established deadlines.					20093	3.0 HRS ARR	(OL)	Ramos,G	ONLINE
Students not in attendance or late for the first class meeting are subject to drop.						The \$20.00 course materials fee includes the eTextbook.			
					20094	3.0 HRS ARR	(OL)	Hu,J	ONLINE
					20095	3.0 HRS ARR	(OL)	STAFF	ONLINE
					21250	3.0 HRS ARR	(OL)	Ramos,G	ONLINE
					21438	3.0 HRS ARR	(OL)	Daltro,M	ONLINE
					21734	3.0 HRS ARR	(OL)	Van Dine,B	ONLINE
					24409	3.0 HRS ARR	(OL)	Wright,W	ONLINE
					27759	11:00-12:15PM	TTh	Grady,J	REMOTE
					25587	6:30- 9:20PM	M	Grady,J	REMOTE
					30374	.0 HRS ARR	(OL)	Keshishyan,P	ONLINE
					26054	3.6 HRS ARR	(OL)	STAFF	ONLINE
					Note: For class and textbook information, go to www.cerritos.edu/business-administration.				
					Class# 26054 meets 08/17/2020-11/27/2020				
					21772	3.6 HRS ARR	(OL)	Demoner,G	ONLINE
					Class# 21772 meets 09/08/2020-12/18/2020				
					27445	6.0 HRS ARR	(OL)	Livingston,R	ONLINE
					Note: For class and textbook information, go to www.cerritos.edu/business-administration.				
					Class# 27445 meets 08/17/2020-10/16/2020				
					26210	6.0 HRS ARR	(OL)	Hu,J	ONLINE
					Note: For class and textbook information, go to www.cerritos.edu/business-administration.				
					Class# 26210 meets 08/17/2020-10/16/2020				

Class#	Time	Day	Instructor	Room	Class#	Time	Day	Instructor	Room
20646	6.0 HRS ARR	(OL)	Moriarty,C	ONLINE	23569	6.0 HRS ARR	(OL)	Moriarty,C	ONLINE
Note: For class and textbook information, go to <a href="http://www.cerritos.edu/business-administration">www.cerritos.edu/business-administration</a> .					Note: For class and textbook information, go to <a href="http://www.cerritos.edu/business-administration">www.cerritos.edu/business-administration</a> .				
Class# 20646 meets 08/17/2020-10/16/2020					Class# 23569 meets 10/19/2020-12/18/2020				
25586	6.0 HRS ARR	(OL)	Hu,J	ONLINE	26781	6.0 HRS ARR	(OL)	Van Dine,B	ONLINE
Note: For class and textbook information, go to <a href="http://www.cerritos.edu/business-administration">www.cerritos.edu/business-administration</a> .					Note: For class and textbook information, go to <a href="http://www.cerritos.edu/business-administration">www.cerritos.edu/business-administration</a> .				
Class# 25586 meets 10/19/2020-12/18/2020					Class# 26781 meets 10/19/2020-12/18/2020				
26211	6.0 HRS ARR	(OL)	Livingston,R	ONLINE	<b>BA 107 - 3.0 UNITS HUMAN RELATIONS IN BUSINESS</b>				
Note: For class and textbook information, go to <a href="http://www.cerritos.edu/business-administration">www.cerritos.edu/business-administration</a> .					Transferable to CSU				
Class# 26211 meets 10/19/2020-12/18/2020					NOTE: a material fee of \$20.00 is required for BA 107				
29847	6.0 HRS ARR	(OL)	STAFF	ONLINE	25588	3.6 HRS ARR	(OL)	Acheson,M	ONLINE
Note: For class and textbook information, go to <a href="http://www.cerritos.edu/business-administration">www.cerritos.edu/business-administration</a> .					The \$20.00 course materials fee includes the eTextbook.				
Class# 29847 meets 10/19/2020-12/18/2020					Note: For class and textbook information, go to <a href="http://www.cerritos.edu/business-administration">www.cerritos.edu/business-administration</a> .				
<b>BA 101 - 3.0 UNITS INTERNATIONAL BUSINESS</b>					Class# 25588 meets 08/17/2020-11/27/2020				
Transferable to CSU					23770 6.0 HRS ARR (OL) Acheson,M ONLINE				
27419 3.0 HRS ARR (OL) Franks Sayed,D ONLINE					Note: For class and textbook information, go to <a href="http://www.cerritos.edu/business-administration">www.cerritos.edu/business-administration</a> .				
Note: Class will meet Tuesday and Thursday the first week and the instructor will inform students of future class meetings.					Class# 23770 meets 08/17/2020-10/16/2020				
22849	6.0 HRS ARR	(OL)	Hu,J	ONLINE	23571	6.0 HRS ARR	(OL)	Wright,W	ONLINE
Note: For class and textbook information, go to <a href="http://www.cerritos.edu/business-administration">www.cerritos.edu/business-administration</a> .					Note: For class and textbook information, go to <a href="http://www.cerritos.edu/business-administration">www.cerritos.edu/business-administration</a> .				
Class# 22849 meets 08/17/2020-10/16/2020					Class# 23571 meets 08/17/2020-10/16/2020				
29848	6.0 HRS ARR	(OL)	STAFF	ONLINE	23570	6.0 HRS ARR	(OL)	Wright,W	ONLINE
Note: For class and textbook information, go to <a href="http://www.cerritos.edu/business-administration">www.cerritos.edu/business-administration</a> .					Note: For class and textbook information, go to <a href="http://www.cerritos.edu/business-administration">www.cerritos.edu/business-administration</a> .				
Class# 29848 meets 10/19/2020-12/18/2020					Class# 23570 meets 08/17/2020-10/16/2020				
25354	6.0 HRS ARR	(OL)	Hu,J	ONLINE	29447	6.0 HRS ARR	(OL)	STAFF	ONLINE
Note: For class and textbook information, go to <a href="http://www.cerritos.edu/business-administration">www.cerritos.edu/business-administration</a> .					Note: For class and textbook information, go to <a href="http://www.cerritos.edu/business-administration">www.cerritos.edu/business-administration</a> .				
Class# 25354 meets 10/19/2020-12/18/2020					Class# 29447 meets 08/17/2020-10/16/2020				
<b>BA 104 - 3.0 UNITS MANAGING CULTURAL DIVERSITY</b>					24420 6.0 HRS ARR (OL) Fantroy,S ONLINE				
Transferable to CSU					Note: For class and textbook information, go to <a href="http://www.cerritos.edu/business-administration">www.cerritos.edu/business-administration</a> .				
26992	6.0 HRS ARR	(OL)	Anaya,J	ONLINE	Class# 24420 meets 10/19/2020-12/18/2020				
Note: For class and textbook information, go to <a href="http://www.cerritos.edu/business-administration">www.cerritos.edu/business-administration</a> .					27420 6.0 HRS ARR (OL) STAFF ONLINE				
Class# 26992 meets 08/17/2020-10/16/2020					Note: For class and textbook information, go to <a href="http://www.cerritos.edu/business-administration">www.cerritos.edu/business-administration</a> .				
21790	6.0 HRS ARR	(OL)	Hu,J	ONLINE	Class# 27420 meets 10/19/2020-12/18/2020				
Note: For class and textbook information, go to <a href="http://www.cerritos.edu/business-administration">www.cerritos.edu/business-administration</a> .					26086 6.0 HRS ARR (OL) Livingston,R ONLINE				
Class# 21790 meets 10/19/2020-12/18/2020					Note: For class and textbook information, go to <a href="http://www.cerritos.edu/business-administration">www.cerritos.edu/business-administration</a> .				
26993	6.0 HRS ARR	(OL)	STAFF	ONLINE	Class# 26086 meets 10/19/2020-12/18/2020				
Note: For class and textbook information, go to <a href="http://www.cerritos.edu/business-administration">www.cerritos.edu/business-administration</a> .					28769 6.0 HRS ARR (OL) STAFF ONLINE				
Class# 26993 meets 10/19/2020-12/18/2020					Note: For class and textbook information, go to <a href="http://www.cerritos.edu/business-administration">www.cerritos.edu/business-administration</a> .				
<b>BA 106 - 3.0 UNITS HUMAN RESOURCE MANAGEMENT</b>					Class# 28769 meets 10/19/2020-12/18/2020				
Transferable to CSU					<b>BA 108 - 3.0 UNITS LABOR MANAGEMENT RELATIONS</b>				
NOTE: a material fee of \$20.00 is required for BA 106					Transferable to CSU				
29094	3.6 HRS ARR	(OL)	Garza,J	ONLINE	27766 6.0 HRS ARR (OL) STAFF ONLINE				
The \$20.00 course materials fee includes the eTextbook.					Note: For class and textbook information, go to <a href="http://www.cerritos.edu/business-administration">www.cerritos.edu/business-administration</a> .				
Note: For class and textbook information, go to <a href="http://www.cerritos.edu/business-administration">www.cerritos.edu/business-administration</a> .					Class# 27766 meets 10/19/2020-12/18/2020				
Class# 29094 meets 08/17/2020-11/27/2020					<b>BA 109 - 3.0 UNITS HUMAN RESOURCE DEVELOPMENT</b>				
24099	6.0 HRS ARR	(OL)	Daltro,M	ONLINE	Transferable to CSU				
Note: For class and textbook information, go to <a href="http://www.cerritos.edu/business-administration">www.cerritos.edu/business-administration</a> .					28277 3.6 HRS ARR (OL) Stevenson,K ONLINE				
Class# 24099 meets 08/17/2020-10/16/2020					Note: For class and textbook information, go to <a href="http://www.cerritos.edu/business-administration">www.cerritos.edu/business-administration</a> .				
26997	6.0 HRS ARR	(OL)	Moriarty,C	ONLINE	Class# 28277 meets 09/08/2020-12/18/2020				
Note: For class and textbook information, go to <a href="http://www.cerritos.edu/business-administration">www.cerritos.edu/business-administration</a> .					27767 6.0 HRS ARR (OL) Demoner,G ONLINE				
Class# 26997 meets 08/17/2020-10/16/2020					Note: For class and textbook information, go to <a href="http://www.cerritos.edu/business-administration">www.cerritos.edu/business-administration</a> .				
26047	6.0 HRS ARR	(OL)	Daltro,M	ONLINE	Class# 27767 meets 08/17/2020-10/16/2020				
Note: For class and textbook information, go to <a href="http://www.cerritos.edu/business-administration">www.cerritos.edu/business-administration</a> .					29849 6.0 HRS ARR (OL) STAFF ONLINE				
Class# 26047 meets 08/17/2020-10/16/2020					Note: For class and textbook information, go to <a href="http://www.cerritos.edu/business-administration">www.cerritos.edu/business-administration</a> .				
22123	6.0 HRS ARR	(OL)	Moriarty,C	ONLINE	Class# 29849 meets 10/19/2020-12/18/2020				
Note: For class and textbook information, go to <a href="http://www.cerritos.edu/business-administration">www.cerritos.edu/business-administration</a> .					<b>BA 110 - 3.0 UNITS ADVERTISING</b>				
Class# 22123 meets 10/19/2020-12/18/2020					Transferable to CSU				
27142	6.0 HRS ARR	(OL)	STAFF	ONLINE	27421 6.0 HRS ARR (OL) Elam,C ONLINE				
Note: For class and textbook information, go to <a href="http://www.cerritos.edu/business-administration">www.cerritos.edu/business-administration</a> .					Note: For class and textbook information, go to <a href="http://www.cerritos.edu/business-administration">www.cerritos.edu/business-administration</a> .				
Class# 27142 meets 10/19/2020-12/18/2020					Class# 27421 meets 08/17/2020-10/16/2020				

If a class displays as **REMOTE** in the schedule, students will be expected to log into the class at a specified day/time (e.g., MW 8-9:15am). If the class displays as **ONLINE** in the schedule, students are permitted to log into the class whenever they are available to complete coursework by the established deadlines.

Students not in attendance or late for the first class meeting are subject to drop.

Class#	Time	Day	Instructor	Room	Class#	Time	Day	Instructor	Room
29729	6.0 HRS ARR	(OL)	STAFF	ONLINE	20651	6.0 HRS ARR	(OL)	Livingston,R	ONLINE
Note: For class and textbook information, go to <a href="http://www.cerritos.edu/business-administration">www.cerritos.edu/business-administration</a> . Class# 29729 meets 10/19/2020-12/18/2020					Note: For class and textbook information, go to <a href="http://www.cerritos.edu/business-administration">www.cerritos.edu/business-administration</a> . Class# 20651 meets 08/17/2020-10/16/2020				
<b>BA 113 - 3.0 UNITS LEGAL ENVIRONMENT OF BUSINESS</b>					27426 6.0 HRS ARR (OL) Ciraulo,J ONLINE				
Transferable to UC, CSU					Note: For class and textbook information, go to <a href="http://www.cerritos.edu/business-administration">www.cerritos.edu/business-administration</a> .				
20649	3.0 HRS ARR	(OL)	Ramos,G	ONLINE	Class# 27426 meets 08/17/2020-10/16/2020				
21439	3.0 HRS ARR	(OL)	Ramos,G	ONLINE	24985	6.0 HRS ARR	(OL)	Ciraulo,J	ONLINE
21773	3.6 HRS ARR	(OL)	Ramos,G	ONLINE	Note: For class and textbook information, go to <a href="http://www.cerritos.edu/business-administration">www.cerritos.edu/business-administration</a> .				
Orientation: Midterm and Final exams to be taken on-campus or online. Further class information will be available at <a href="http://www.cerritos.edu/business-administration">www.cerritos.edu/business-administration</a> . Class# 21773 meets 08/17/2020-11/27/2020					Class# 24985 meets 08/17/2020-10/16/2020				
25589	3.6 HRS ARR	(OL)	Ramos,G	ONLINE	23573	6.0 HRS ARR	(OL)	Grady,J	ONLINE
Orientation: Midterm and Final exams to be taken on-campus or online. Further class information will be available at <a href="http://www.cerritos.edu/business-administration">www.cerritos.edu/business-administration</a> . Class# 25589 meets 09/08/2020-12/18/2020					Note: For class and textbook information, go to <a href="http://www.cerritos.edu/business-administration">www.cerritos.edu/business-administration</a> .				
26212	3.6 HRS ARR	(OL)	Paquette,R	ONLINE	Class# 23573 meets 08/17/2020-10/16/2020				
Orientation: Midterm and Final exams to be taken on-campus or online. Further class information will be available at <a href="http://www.cerritos.edu/business-administration">www.cerritos.edu/business-administration</a> . Class# 26212 meets 09/08/2020-12/18/2020					22063	6.0 HRS ARR	(OL)	Livingston,R	ONLINE
Class# 26212 meets 09/08/2020-12/18/2020					Note: For class and textbook information, go to <a href="http://www.cerritos.edu/business-administration">www.cerritos.edu/business-administration</a> .				
<b>25664</b>	<b>6:30-9:50PM</b>	<b>T</b>	EIarcosa,J	REMOTE	Class# 22063 meets 10/19/2020-12/18/2020				
Class# 25664 meets 09/08/2020-12/15/2020					23574	6.0 HRS ARR	(OL)	Moriarty,C	ONLINE
22851	6.0 HRS ARR	(OL)	EIarcosa,J	ONLINE	Note: For class and textbook information, go to <a href="http://www.cerritos.edu/business-administration">www.cerritos.edu/business-administration</a> .				
Orientation: Midterm and Final exams to be taken on-campus or online. Further class information will be available at <a href="http://www.cerritos.edu/business-administration">www.cerritos.edu/business-administration</a> . Class# 22851 meets 08/17/2020-10/16/2020					Class# 23574 meets 10/19/2020-12/18/2020				
27422	6.0 HRS ARR	(OL)	Daltro,M	ONLINE	24421	6.0 HRS ARR	(OL)	Ciraulo,J	ONLINE
Orientation: Midterm and Final exams to be taken on-campus or online. Further class information will be available at <a href="http://www.cerritos.edu/business-administration">www.cerritos.edu/business-administration</a> . Class# 27422 meets 10/19/2020-12/18/2020					Note: For class and textbook information, go to <a href="http://www.cerritos.edu/business-administration">www.cerritos.edu/business-administration</a> .				
29850	6.0 HRS ARR	(OL)	Daltro,M	ONLINE	Class# 24421 meets 10/19/2020-12/18/2020				
Orientation: Midterm and Final exams to be taken on-campus or online. Further class information will be available at <a href="http://www.cerritos.edu/business-administration">www.cerritos.edu/business-administration</a> . Class# 29850 meets 10/19/2020-12/18/2020					27448	6.0 HRS ARR	(OL)	STAFF	ONLINE
Class# 29850 meets 10/19/2020-12/18/2020					Note: For class and textbook information, go to <a href="http://www.cerritos.edu/business-administration">www.cerritos.edu/business-administration</a> .				
<b>BA 114 - 3.0 UNITS MARKETING</b>					Class# 27448 meets 10/19/2020-12/18/2020				
Transferable to CSU					<b>BA 118 - 3.0 UNITS RETAIL MANAGEMENT</b>				
NOTE: a material fee of \$20.00 is required for BA 114					Transferable to CSU				
22126	11:00-12:15PM	MW	Chugh,R	REMOTE	NOTE: a material fee of \$20.00 is required for BA 118				
The \$20.00 course materials fee includes the eTextbook.					The \$20.00 course materials fee includes the eTextbook.				
20098	6.0 HRS ARR	(OL)	Baber,J	ONLINE	Note: For class and textbook information, go to <a href="http://www.cerritos.edu/business-administration">www.cerritos.edu/business-administration</a> .				
Note: For class and textbook information, go to <a href="http://www.cerritos.edu/business-administration">www.cerritos.edu/business-administration</a> . Class# 20098 meets 08/17/2020-10/16/2020					Class# 22852 meets 08/17/2020-10/16/2020				
27447	6.0 HRS ARR	(OL)	Livingston,R	ONLINE	24412	6.0 HRS ARR	(OL)	Ciraulo,T	ONLINE
Note: For class and textbook information, go to <a href="http://www.cerritos.edu/business-administration">www.cerritos.edu/business-administration</a> . Class# 27447 meets 08/17/2020-10/16/2020					Note: For class and textbook information, go to <a href="http://www.cerritos.edu/business-administration">www.cerritos.edu/business-administration</a> .				
22854	6.0 HRS ARR	(OL)	Moriarty,C	ONLINE	Class# 24412 meets 08/17/2020-10/16/2020				
Note: For class and textbook information, go to <a href="http://www.cerritos.edu/business-administration">www.cerritos.edu/business-administration</a> . Class# 22854 meets 08/17/2020-10/16/2020					26215	6.0 HRS ARR	(OL)	Ghidella,R	ONLINE
20650	6.0 HRS ARR	(OL)	Livingston,R	ONLINE	Note: For class and textbook information, go to <a href="http://www.cerritos.edu/business-administration">www.cerritos.edu/business-administration</a> .				
Note: For class and textbook information, go to <a href="http://www.cerritos.edu/business-administration">www.cerritos.edu/business-administration</a> . Class# 20650 meets 10/19/2020-12/18/2020					Class# 26215 meets 08/17/2020-10/16/2020				
22124	6.0 HRS ARR	(OL)	Ciraulo,T	ONLINE	27762	6.0 HRS ARR	(OL)	Baber,J	ONLINE
Note: For class and textbook information, go to <a href="http://www.cerritos.edu/business-administration">www.cerritos.edu/business-administration</a> . Class# 22124 meets 10/19/2020-12/18/2020					Note: For class and textbook information, go to <a href="http://www.cerritos.edu/business-administration">www.cerritos.edu/business-administration</a> .				
26050	6.0 HRS ARR	(OL)	Ramos,G	ONLINE	Class# 27762 meets 10/19/2020-12/18/2020				
Note: For class and textbook information, go to <a href="http://www.cerritos.edu/business-administration">www.cerritos.edu/business-administration</a> . Class# 26050 meets 10/19/2020-12/18/2020					29095	6.0 HRS ARR	STAFF	ONLINE	
27761	6.0 HRS ARR	(OL)	Ciraulo,T	ONLINE	Note: For class and textbook information, go to <a href="http://www.cerritos.edu/business-administration">www.cerritos.edu/business-administration</a> .				
Note: For class and textbook information, go to <a href="http://www.cerritos.edu/business-administration">www.cerritos.edu/business-administration</a> . Class# 27761 meets 10/19/2020-12/18/2020					Class# 29095 meets 10/19/2020-12/18/2020				
<b>BA 115 - 3.0 UNITS MANAGEMENT-BUSINESS</b>					29096 6.0 HRS ARR (OL) STAFF ONLINE				
Transferable to CSU					Note: For class and textbook information, go to <a href="http://www.cerritos.edu/business-administration">www.cerritos.edu/business-administration</a> . Class# 29096 meets 10/19/2020-12/18/2020				
NOTE: a material fee of \$20.00 is required for BA 115					<b>BA 120 - 3.0 UNITS MANAGEMENT-ACCOUNTING AND INTERNAL CONTROL</b>				
21441	3.6 HRS ARR	(OL)	Abadi,M	ONLINE	Transferable to CSU				
The \$20.00 course materials fee includes the eTextbook. Class# 21441 meets 09/08/2020-12/18/2020					NOTE: a material fee of \$20.00 is required for BA 120				
Class# 21441 meets 09/08/2020-12/18/2020					The \$20.00 course materials fee includes the eTextbook.				
Class# 21441 meets 09/08/2020-12/18/2020					Note: For class and textbook information, go to <a href="http://www.cerritos.edu/business-administration">www.cerritos.edu/business-administration</a> .				
Class# 21441 meets 09/08/2020-12/18/2020					Class# 22551 meets 08/17/2020-11/27/2020				
Class# 21441 meets 09/08/2020-12/18/2020					25590	6.0 HRS ARR	(OL)	Baber,J	ONLINE
Class# 21441 meets 09/08/2020-12/18/2020					Note: For class and textbook information, go to <a href="http://www.cerritos.edu/business-administration">www.cerritos.edu/business-administration</a> . Class# 25590 meets 08/17/2020-10/16/2020				

If a class displays as **REMOTE** in the schedule, students will be expected to log into the class at a specified day/time (e.g., MW 8-9:15am). If the class displays as **ONLINE** in the schedule, students are permitted to log into the class whenever they are available to complete coursework by the established deadlines.

Students not in attendance or late for the first class meeting are subject to drop.

Class#	Time	Day	Instructor	Room	Class#	Time	Day	Instructor	Room
26216	6.0 HRS ARR	(OL)	Keshishyan,P	ONLINE					
Note: For class and textbook information, go to <a href="http://www.cerritos.edu/business-administration">www.cerritos.edu/business-administration</a> . Class# 26216 meets 08/17/2020-10/16/2020									
26218	6.0 HRS ARR	(OL)	Keshishyan,P	ONLINE	21774	6.0 HRS ARR	(OL)	Anaya,J	ONLINE
Note: For class and textbook information, go to <a href="http://www.cerritos.edu/business-administration">www.cerritos.edu/business-administration</a> . Class# 26218 meets 10/19/2020-12/18/2020					Note: For class and textbook information, go to <a href="http://www.cerritos.edu/business-administration">www.cerritos.edu/business-administration</a> . Class# 21774 meets 08/17/2020-10/16/2020				
27763	6.0 HRS ARR	(OL)	Fantroy,S	ONLINE	27427	6.0 HRS ARR	(OL)	Jo,J	ONLINE
Note: For class and textbook information, go to <a href="http://www.cerritos.edu/business-administration">www.cerritos.edu/business-administration</a> . Class# 27763 meets 10/19/2020-12/18/2020					Note: For class and textbook information, go to <a href="http://www.cerritos.edu/business-administration">www.cerritos.edu/business-administration</a> . Class# 27427 meets 10/19/2020-12/18/2020				
<b>BA 121 - 3.0 UNITS SALES</b> Transferable to CSU					<b>BA 153 - 3.0 UNITS INTRODUCTION TO ENTREPRENEURSHIP</b> Transferable to CSU				
20099	6.0 HRS ARR	(OL)	Munoz,D	ONLINE	26055	6.0 HRS ARR	(OL)	Brown,S	ONLINE
Note: For class and textbook information, go to <a href="http://www.cerritos.edu/business-administration">www.cerritos.edu/business-administration</a> . Class# 20099 meets 08/17/2020-10/16/2020					Recommendation: BA 101 or equivalent with a grade of Pass or "C" or higher. Class# 26055 meets 10/19/2020-12/18/2020				
28285	6.0 HRS ARR	(OL)	Elam,C	ONLINE	<b>BA 155 - 3.0 UNITS INTRODUCTION TO GLOBAL LOGISTICS</b> Transferable to CSU				
Note: For class and textbook information, go to <a href="http://www.cerritos.edu/business-administration">www.cerritos.edu/business-administration</a> . Class# 28285 meets 10/19/2020-12/18/2020					Recommendation: BA 101 or equivalent with a grade of Pass or "C" or higher.				
<b>BA 126 - 3.0 UNITS E-LEARNING</b> Transferable to CSU					<b>BA 156 - 3.0 UNITS MOTIVATIONAL PRESENTATION SKILLS FOR MANAGERS</b> Transferable to CSU				
30019	3.6 HRS ARR	(OL)	Garza,J	ONLINE	30020	3.0 HRS ARR	(OL)	STAFF	ONLINE
Class# 30019 meets 08/17/2020-11/27/2020					NOTE: a material fee of \$20.00 is required for BA 156 The \$20.00 course materials fee includes the eTextbook. Note: For class and textbook information, go to <a href="http://www.cerritos.edu/business-administration">www.cerritos.edu/business-administration</a> .				
<b>BA 132 - 3.0 UNITS COMPUTER APPLICATIONS FOR MANAGERS</b> Transferable to CSU					25592	3.6 HRS ARR	(OL)	STAFF	ONLINE
27760	3.0 HRS ARR	(OL)	Acheson,M	ONLINE	Note: For class and textbook information, go to <a href="http://www.cerritos.edu/business-administration">www.cerritos.edu/business-administration</a> . Class# 25592 meets 08/17/2020-11/27/2020				
The \$20.00 course materials fee includes the eTextbook.					22287	6.0 HRS ARR	(OL)	Celestine,M	ONLINE
26545	6.0 HRS ARR	(OL)	Garza,J	ONLINE	Note: For class and textbook information, go to <a href="http://www.cerritos.edu/business-administration">www.cerritos.edu/business-administration</a> . Class# 22287 meets 08/17/2020-10/16/2020				
Note: For class and textbook information, go to <a href="http://www.cerritos.edu/business-administration">www.cerritos.edu/business-administration</a> . Class# 26545 meets 08/17/2020-10/16/2020					23771	6.0 HRS ARR	(OL)	Stevenson,K	ONLINE
22554	6.0 HRS ARR	(OL)	Franks Sayed,D	ONLINE	Note: For class and textbook information, go to <a href="http://www.cerritos.edu/business-administration">www.cerritos.edu/business-administration</a> . Class# 23771 meets 08/17/2020-10/16/2020				
Note: For class and textbook information, go to <a href="http://www.cerritos.edu/business-administration">www.cerritos.edu/business-administration</a> . Class# 22554 meets 08/17/2020-10/16/2020					26737	6.0 HRS ARR	(OL)	STAFF	ONLINE
22553	6.0 HRS ARR	(OL)	Stevenson,K	ONLINE	Note: For class and textbook information, go to <a href="http://www.cerritos.edu/business-administration">www.cerritos.edu/business-administration</a> . Class# 26737 meets 10/19/2020-12/18/2020				
Note: For class and textbook information, go to <a href="http://www.cerritos.edu/business-administration">www.cerritos.edu/business-administration</a> . Class# 22553 meets 08/17/2020-10/16/2020					27145	6.0 HRS ARR	(OL)	Celestine,M	ONLINE
25158	6.0 HRS ARR	(OL)	Anaya,J	ONLINE	Note: For class and textbook information, go to <a href="http://www.cerritos.edu/business-administration">www.cerritos.edu/business-administration</a> . Class# 27145 meets 10/19/2020-12/18/2020				
Note: For class and textbook information, go to <a href="http://www.cerritos.edu/business-administration">www.cerritos.edu/business-administration</a> . Class# 25158 meets 08/17/2020-10/16/2020					29097	6.0 HRS ARR	(OL)	Gray,G	ONLINE
27764	6.0 HRS ARR	(OL)	Wright,W	ONLINE	Note: For class and textbook information, go to <a href="http://www.cerritos.edu/business-administration">www.cerritos.edu/business-administration</a> . Class# 29097 meets 10/19/2020-12/18/2020				
Note: For class and textbook information, go to <a href="http://www.cerritos.edu/business-administration">www.cerritos.edu/business-administration</a> . Class# 27764 meets 10/19/2020-12/18/2020					<b>BA 157 - 3.0 UNITS PRINCIPLES OF PUBLIC RELATIONS</b> Transferable to CSU				
27765	6.0 HRS ARR	(OL)	Wright,W	ONLINE	22661	6.0 HRS ARR	(OL)	Moriarty,C	ONLINE
Note: For class and textbook information, go to <a href="http://www.cerritos.edu/business-administration">www.cerritos.edu/business-administration</a> . Class# 27765 meets 10/19/2020-12/18/2020					Note: For class and textbook information, go to <a href="http://www.cerritos.edu/business-administration">www.cerritos.edu/business-administration</a> . Class# 22661 meets 08/17/2020-10/16/2020				
29448	6.0 HRS ARR	(OL)	Wright,W	ONLINE	<b>BA 204 - 3.0 UNITS PROJECT MANAGEMENT</b> Transferable to CSU				
Note: For class and textbook information, go to <a href="http://www.cerritos.edu/business-administration">www.cerritos.edu/business-administration</a> . Class# 29448 meets 10/19/2020-12/18/2020					23585	6.0 HRS ARR	(OL)	Brown,S	ONLINE
29851	6.0 HRS ARR	(OL)	STAFF	ONLINE	Note: For class and textbook information, go to <a href="http://www.cerritos.edu/business-administration">www.cerritos.edu/business-administration</a> . Class# 23585 meets 10/19/2020-12/18/2020				
Note: For class and textbook information, go to <a href="http://www.cerritos.edu/business-administration">www.cerritos.edu/business-administration</a> . Class# 29851 meets 10/19/2020-12/18/2020					<b>BA 205 - 3.0 UNITS ORGANIZATIONAL LEADERSHIP</b> Transferable to CSU				
<b>BA 152 - 3.0 UNITS FUNDAMENTALS OF IMPORTING AND EXPORTING</b> Transferable to CSU					23586	6.0 HRS ARR	(OL)	Dokter,D	ONLINE
27285	6.0 HRS ARR	(OL)	Brown,S	ONLINE	Note: For class and textbook information, go to <a href="http://www.cerritos.edu/business-administration">www.cerritos.edu/business-administration</a> . Class# 23586 meets 08/17/2020-10/16/2020				
Note: For class and textbook information, go to <a href="http://www.cerritos.edu/business-administration">www.cerritos.edu/business-administration</a> . Class# 27285 meets 10/19/2020-12/18/2020					29730	6.0 HRS ARR	(OL)	Munoz,D	ONLINE
					Note: For class and textbook information, go to <a href="http://www.cerritos.edu/business-administration">www.cerritos.edu/business-administration</a> . Class# 29730 meets 10/19/2020-12/18/2020				

If a class displays as **REMOTE** in the schedule, students will be expected to log into the class at a specified day/time (e.g., MW 8-9:15am). If the class displays as **ONLINE** in the schedule, students are permitted to log into the class whenever they are available to complete coursework by the established deadlines.

Students not in attendance or late for the first class meeting are subject to drop.



Class#	Time	Day	Instructor	Room	Class#	Time	Day	Instructor	Room
<b>BA 208 - 3.0 UNITS LEADERSHIP FOR WOMEN IN BUSINESS</b>					<b>BCOT 96 - 1.5 UNITS MICROSOFT POWERPOINT</b>				
Transferable to UC, CSU					Not Transferable				
22549	6.0 HRS ARR	(OL)	Livingston,B	(Women's Studies) ONLINE	29114	3.0 HRS ARR	(OL)	Wyszpolski,J	ONLINE
Note: For class and textbook information, go to www.cerritos.edu/business-administration.					NOTE: a material fee of \$2.00 is required for BCOT 96				
Class# 22549 meets 08/17/2020-10/16/2020					+ 2.0 HRS ARR (OL) Wyszpolski,J				
25738	6.0 HRS ARR	(OL)	Livingston,B	(Women's Studies) ONLINE	All class information will be available in Canvas.				
Note: For class and textbook information, go to www.cerritos.edu/business-administration.					Class# 29114 meets 08/17/2020-10/16/2020				
Class# 25738 meets 10/19/2020-12/18/2020					<b>BCOT 97 - 1.5 UNITS MICROSOFT OUTLOOK</b>				
26221	6.0 HRS ARR	(OL)	Livingston,B	(Women's Studies) ONLINE	Not Transferable				
Note: For class and textbook information, go to www.cerritos.edu/business-administration.					NOTE: a material fee of \$2.00 is required for BCOT 97				
Class# 26221 meets 10/19/2020-12/18/2020					21350	3.0 HRS ARR	(OL)	Doucette,E	ONLINE
					+ 2.0 HRS ARR (OL) Doucette,E				
					All class information will be available in Canvas.				
					Class# 21350 meets 10/19/2020-12/18/2020				
					<b>BCOT 112 - 3.5 UNITS MICROSOFT WORD</b>				
					Transferable to CSU				
					Recommendation: Ability to type 30 wpm.				
					NOTE: a material fee of \$4.00 is required for BCOT 112				
					21357	6.0 HRS ARR	(OL)	Sharp,M	ONLINE
					+ 4.0 HRS ARR (OL) Sharp,M				
					All class information will be available in Canvas.				
					Class# 21357 meets 08/17/2020-10/16/2020				
					<b>BCOT 113 - 3.5 UNITS MICROSOFT EXCEL</b>				
					Transferable to CSU				
					NOTE: a material fee of \$4.00 is required for BCOT 113				
22856	3.0 HRS ARR	(OL)	STAFF	ONLINE	25596	6.0 HRS ARR	(OL)	Doucette,E	ONLINE
All class information will be available in Canvas. Class offered only in the FALL semester.					+ 4.0 HRS ARR (OL) Doucette,E				
Class# 22856 meets 09/28/2020-11/06/2020					All class information will be available in Canvas.				
					Class# 25596 meets 08/17/2020-10/14/2020				
					21359	6.0 HRS ARR	(OL)	Sharp,M	ONLINE
					+ 4.0 HRS ARR (OL) Sharp,M				
					All class information will be available in Canvas.				
					Class# 21359 meets 10/19/2020-12/18/2020				
					<b>BCOT 114 - 3.5 UNITS INTRODUCTION TO MICROSOFT OFFICE</b>				
					Transferable to CSU				
					Recommendation: Ability to type 30 wpm.				
					NOTE: a material fee of \$4.00 is required for BCOT 114				
21488	3.0 HRS ARR	(OL)	Wyszpolski,J	ONLINE	29116	3.0 HRS ARR	(OL)	Soden,B	ONLINE
+ 1.5 HRS ARR (OL) Wyszpolski,J					+ 2.0 HRS ARR (OL) Soden,B				
All class information will be available in Canvas.					All class information will be available in Canvas. Submit student information form in Canvas for initial roll.				
Class# 21488 meets 08/17/2020-09/25/2020									
27728	3.0 HRS ARR	(OL)	Wyszpolski,J	ONLINE	<b>BCOT 118 - 1.5 UNITS MICROSOFT ACCESS FOR OFFICE TECHNOLOGY</b>				
+ 1.0 HRS ARR (OL) Wyszpolski,J					Transferable to CSU				
All class information will be available in Canvas.					30495	4.5 HRS ARR	(OL)	Wyszpolski,J	ONLINE
Class# 27728 meets 09/28/2020-11/06/2020					+ 3.0 HRS ARR (OL) Wyszpolski,J				
					All class information will be available in Canvas.				
					Class# 30495 meets 10/19/2020-11/25/2020				
					<b>BCOT 148 - 3.0 UNITS EFFECTIVE BUSINESS PRESENTATIONS</b>				
					Transferable to CSU				
					Recommendation: BCOT 96 and BCOT 147 or equivalent with a grade of "C" or higher, or "Pass".				
30031	4.0 HRS ARR	(OL)	STAFF	ONLINE	29684	6.0 HRS ARR	(OL)	Doucette,E	ONLINE
+ 2.0 HRS ARR (OL) STAFF					All class information will be available in Canvas.				
All class information will be available in Canvas.					Class# 29684 meets 10/19/2020-12/18/2020				
					<b>BCOT 162 - 3.0 UNITS BUSINESS SPELLING AND PROOFREADING SKILLS</b>				
					Transferable to CSU				
					Recommendation: MA 60 and MA 161.				
					NOTE: a material fee of \$4.00 is required for BCOT 71				
30493	3.0 HRS ARR		STAFF	ONLINE	26202	3.0 HRS ARR	(OL)	Sharp,M	ONLINE
30494	+ 2.0 HRS ARR		STAFF	ONLINE	All class information will be available in Canvas. Class offered only in the FALL semester.				
All class information will be available in Canvas.									
					<b>BCOT 247 - 3.0 UNITS MANAGERIAL BUSINESS COMMUNICATIONS</b>				
					Transferable to CSU				
					Prerequisite: ENGL 100 or ENGL 100S equivalent with a grade of "C" or higher or "Pass".				
29274	3.0 HRS ARR	(OL)	Doucette,E	ONLINE	25410	3.0 HRS ARR	(OL)	Sharp,M	ONLINE
+ 1.5 HRS ARR (OL) Doucette,E					All class information will be available in Canvas. Orientation Monday, August 17, 9:30 a.m., BE 120				
All class information will be available in Canvas. Class offered only in the FALL semester.					25667	9:30-10:45AM	MW	Sharp,M	(HYBRID) REMOTE
					First week of class will meet on Monday and Wednesday; future classes will meet only on Wednesdays.				

## BUSINESS COMMUNICATIONS OFFICE TECHNOLOGY

<b>BCOT 60 - 1.0 UNIT CUSTOMER SERVICE/TELEPHONE TECHNIQUES</b>				
Not Transferable				
22856	3.0 HRS ARR	(OL)	STAFF	ONLINE
All class information will be available in Canvas. Class offered only in the FALL semester.				
Class# 22856 meets 09/28/2020-11/06/2020				
<b>BCOT 62 - 1.0 UNIT COMPUTER KEYBOARDING</b>				
Not Transferable				
NOTE: a material fee of \$1.00 is required for BCOT 62				
21346	3.0 HRS ARR	(OL)	Sharp,M	ONLINE
+ 1.5 HRS ARR (OL) Sharp,M				
All class information will be available in Canvas.				
Class# 21346 meets 08/17/2020-09/25/2020				
<b>BCOT 63 - 1.0 UNIT KEYBOARDING SPEED/CONTROL BUILDING</b>				
Not Transferable				
Recommendation: Knowledge of keyboard and key strokes.				
NOTE: a material fee of \$1.00 is required for BCOT 63				
21488	3.0 HRS ARR	(OL)	Wyszpolski,J	ONLINE
+ 1.5 HRS ARR (OL) Wyszpolski,J				
All class information will be available in Canvas.				
Class# 21488 meets 08/17/2020-09/25/2020				
27728	3.0 HRS ARR	(OL)	Wyszpolski,J	ONLINE
+ 1.0 HRS ARR (OL) Wyszpolski,J				
All class information will be available in Canvas.				
Class# 27728 meets 09/28/2020-11/06/2020				
<b>BCOT 70 - 4.0 UNITS MEDICAL MACHINE TRANSCRIPT</b>				
Not Transferable				
Prerequisite: BCOT 46, BCOT 131, BCOT 162 and MA 161 or their equivalents with grades of Pass or "C" or higher, or concurrent enrollment in these courses.				
Recommendation: Ability to type 30 wpm.				
NOTE: a material fee of \$4.00 is required for BCOT 70				
30031	4.0 HRS ARR	(OL)	STAFF	ONLINE
+ 2.0 HRS ARR (OL) STAFF				
All class information will be available in Canvas.				
<b>BCOT 71 - 3.5 UNITS COMPUTERS IN THE MEDICAL OFFICE</b>				
Not Transferable				
Recommendation: MA 60 and MA 161.				
NOTE: a material fee of \$4.00 is required for BCOT 71				
30493	3.0 HRS ARR		STAFF	ONLINE
30494	+ 2.0 HRS ARR		STAFF	ONLINE
All class information will be available in Canvas.				
<b>BCOT 81 - 4.0 UNITS LEGAL OFFICE PROCEDURES</b>				
Not Transferable				
Recommendation: BCOT 131 or equivalent with a grade of "C" or higher or "Pass".				
NOTE: a material fee of \$4.00 is required for BCOT 81				
29274	3.0 HRS ARR	(OL)	Doucette,E	ONLINE
+ 1.5 HRS ARR (OL) Doucette,E				
All class information will be available in Canvas. Class offered only in the FALL semester.				

If a class displays as **REMOTE** in the schedule, students will be expected to log into the class at a specified day/time (e.g., MW 8-9:15am). If the class displays as **ONLINE** in the schedule, students are permitted to log into the class whenever they are available to complete coursework by the established deadlines.

Students not in attendance or late for the first class meeting are subject to drop.

Class#	Time	Day	Instructor	Room	Class#	Time	Day	Instructor	Room
25668	3.0 HRS ARR	(OL)	Doucette,E	ONLINE					
All class information will be available in Canvas.									
<b>30376</b>	<b>6:00-7:15PM</b>	<b>TTh</b>	Doucette,E (HYBRID)	REMOTE					
First week of class will meet on Tuesday and Thursday; future classes will meet only on Tuesdays.									

## CHEMISTRY

### CHEMISTRY DEPARTMENT COURSE SEQUENCE

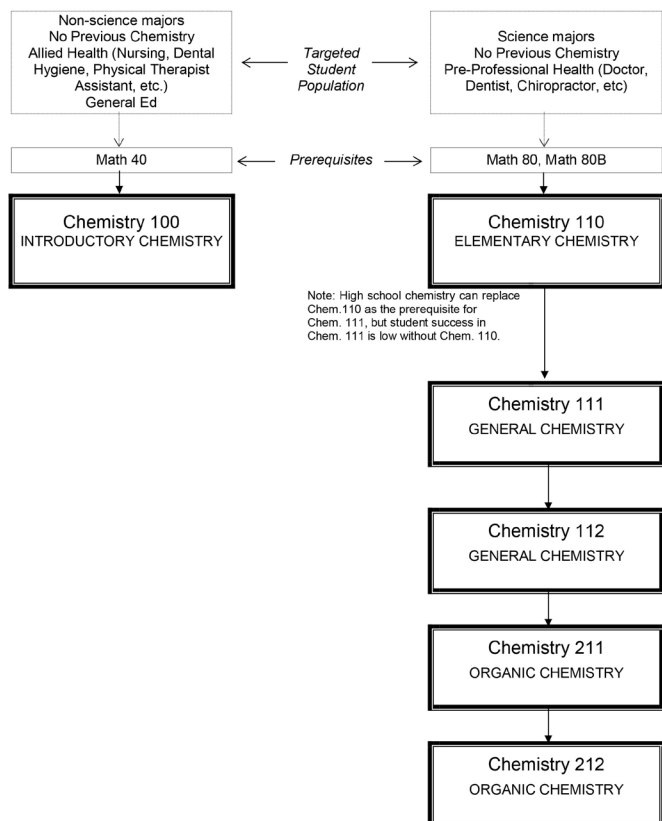

#### CHEM 100 - 4.0 UNITS INTRODUCTORY CHEMISTRY

Transferable to UC, CSU (CAN CHEM 6)  
Prerequisite: MATH 40 or equivalent with a grade of "C" or higher or "Pass" or completion of the math placement process with a score eligible for MATH 60.  
Recommendation: Meet the prerequisite within four years prior to the date of enrollment in CHEM 100.

20002	+ 3.0 HRS ARR	(OL)	Waldman,L	ONLINE
20003	3.0 HRS ARR	(OL)	Waldman,L	ONLINE
20004	3.0 HRS ARR	(OL)	Khodagholian,S	ONLINE
30201	3.0 HRS ARR	(OL)	Khodagholian,S	ONLINE
	+ 3.0 HRS ARR	(OL)	Waldman,L	ONLINE
24299	3.0 HRS ARR	(OL)	Trieu,T	ONLINE
29356	3.0 HRS ARR	(OL)	Trieu,T	ONLINE
	+ 3.0 HRS ARR	(OL)	Trieu,T	ONLINE
25399	+ 3.0 HRS ARR	(OL)	Waldman,L	ONLINE
29355	3.0 HRS ARR	(OL)	Mays-Larson,P	ONLINE
24296	+ 3.0 HRS ARR	(OL)	Waldman,L	ONLINE
25400	3.0 HRS ARR	(OL)	Mays-Larson,P	ONLINE
24297	3.0 HRS ARR	(OL)	Chen,K	ONLINE
	+ 3.0 HRS ARR	(OL)	Waldman,L	ONLINE
<b>26762</b>	<b>5:00-6:15PM</b>	<b>MW</b>	Dukhovny,O	REMOTE
<b>26763</b>	<b>7:00-9:50PM</b>	<b>W</b>	Mays-Larson,P	REMOTE

#### CHEM 110 - 4.0 UNITS ELEMENTARY CHEMISTRY

Transferable to UC, CSU  
Prerequisite: MATH 80 or MATH 80B or equivalent with a grade of "C" or higher or "Pass" or completion of the math placement process with a score eligible for MATH courses numbered 100 level or higher.  
Recommendation: Meet the prerequisite within four years prior to the date of enrollment in CHEM 110.

20006	11:00-12:15PM	TTh	Nguyen,H	REMOTE
20009	8:00-10:50AM	Th	Bradbury,J	REMOTE
Targeted for Future Teachers but Open to All Students				
20008	12:30-1:45PM	TTh	Bonness Jr.,N	REMOTE
22649	2:00-4:50PM	Th	Bonness Jr.,N	REMOTE
<b>20026</b>	<b>5:30-6:45PM</b>	<b>MW</b>	Chen,K	REMOTE
<b>20028</b>	<b>7:00-9:50PM</b>	<b>M</b>	Chen,K	REMOTE
24300	2:30-5:20PM	W	Mathur,R	REMOTE
	1:00-2:15PM	MW	Mathur,R	REMOTE
<b>25608</b>	<b>5:00-6:15PM</b>	<b>TTh</b>	Bonness Jr.,N	REMOTE
25609	2:00-4:50PM	T	Bonness Jr.,N	REMOTE
<b>20010</b>	<b>7:00-9:50PM</b>	<b>T</b>	Nguyen,H	REMOTE
	<b>5:30-6:45PM</b>	<b>TTh</b>	Nguyen,H	REMOTE

#### CHEM 111 - 5.0 UNITS GENERAL CHEMISTRY

Transferable to UC, CSU (CAN CHEM 2)(CAN CHEM SEQ A)  
Prerequisite: CHEM 110 or equivalent with a grade of "C" or higher or "Pass" and MATH 80 or MATH 80B or equivalent with a grade of "C" or higher or "Pass" or completion of the math placement process with a score eligible for MATH courses numbered 100 level or higher.  
Recommendation: Meet the prerequisite within four years prior to the date of enrollment in CHEM 111.

20013	11:00-12:15PM	MW	Moskun,A	REMOTE
20015	8:00-10:50AM	MW	Moskun,A	REMOTE
<b>30634</b>	<b>5:30-6:45PM</b>	<b>MW</b>	Bonness Jr.,N	REMOTE
30635	2:00-4:50PM	MW	Bonness Jr.,N	REMOTE
20017	8:00-10:50AM	TTh	Moskun,A	REMOTE
	12:30-1:45PM	TTh	Moskun,A	REMOTE
<b>21263</b>	<b>7:00-9:50PM</b>	<b>MW</b>	Flores,J	REMOTE
	<b>5:30-6:45PM</b>	<b>MW</b>	Flores,J	REMOTE
<b>23999</b>	<b>5:30-6:45PM</b>	<b>TTh</b>	Ho,T	REMOTE
<b>24000</b>	<b>7:00-9:50PM</b>	<b>TTh</b>	Ho,T	REMOTE

#### CHEM 112 - 5.0 UNITS GENERAL CHEMISTRY

Transferable to UC, CSU (CAN CHEM 4)(CAN CHEM SEQ A)  
Prerequisite: CHEM 111 or equivalent with a grade of "C" or higher or "Pass."  
Recommendation: It is strongly recommended that the preceding prerequisite be completed within four years prior to the date of enrollment in CHEM 112.

20018	12:30-1:45PM	TTh	Bradbury,J	REMOTE
20019	2:00-4:50PM	TTh	Bradbury,J	REMOTE
21736	12:30-1:45PM	MW	Bradbury,J	REMOTE
21737	2:00-4:50PM	MW	Bradbury,J	REMOTE

#### CHEM 211 - 5.0 UNITS ORGANIC CHEMISTRY

Transferable to UC, CSU  
Prerequisite: CHEM 112 or equivalent with a grade of "C" or higher or "Pass."  
Recommendation: It is strongly recommended that the preceding prerequisite be completed within four years prior to the date of enrollment in CHEM 211.

20023	6.0 HRS ARR	(OL)	Lou,R	ONLINE
	12:30-1:45PM	TTh	Lou,R	REMOTE
Note: A proctoring program will be used for all tests in this course. Therefore, you must have access to a computer or laptop with a webcam and microphone.				
25406	6.0 HRS ARR	(OL)	Lou,R	ONLINE

#### CHEM 212 - 5.0 UNITS ORGANIC CHEMISTRY

Transferable to UC, CSU  
Prerequisite: CHEM 211 or equivalent with a grade of "C" or higher or "Pass."  
Recommendation: It is strongly recommended that the preceding prerequisite be completed within four years prior to the date of enrollment in CHEM 212.

<b>26195</b>	<b>5:30-6:45PM</b>	<b>TTh</b>	Hajjawi,A	REMOTE
Note: A proctoring program will be used for all tests in this course. Therefore, you must have access to a computer or laptop with a webcam and microphone.				
26196	6.0 HRS ARR	(OL)	Hajjawi,A	ONLINE

If a class displays as **REMOTE** in the schedule, students will be expected to log into the class at a specified day/time (e.g., MW 8-9:15am). If the class displays as **ONLINE** in the schedule, students are permitted to log into the class whenever they are available to complete coursework by the established deadlines.

Students not in attendance or late for the first class meeting are subject to drop.

## CHILD DEVELOPMENT

### Earn a Bachelor's Degree with the University of La Verne

Cerritos College and La Verne have created a partnership to provide students an opportunity to earn a bachelor's degree in child development. Students may take La Verne upper division courses while completing Cerritos GE courses. The program has accelerated 10 week semesters.



**BS Child Development**  
For more information contact:  
(909) 593-3511, Ext. 5436

#### CD 110 - 3.0 UNITS CHILD DEVELOPMENT

Transferable to UC, CSU (CAN HEC 14)

20120	3.0 HRS ARR	(OL)	Gradin,S	ONLINE
Targeted for Future Teachers but Open to all Students				
20121	3.0 HRS ARR	(OL)	Pullman,S	ONLINE
Targeted for Future Teachers but Open to all Students				
23800	3.0 HRS ARR	(OL)	Gibson,D	ONLINE
Targeted for Future Teachers but Open to all Students				
20122	3.0 HRS ARR	(OL)	Beck,A	ONLINE
Targeted for Future Teachers but Open to all Students				
22181	3.0 HRS ARR	(OL)	Roque,G	ONLINE
23805	3.0 HRS ARR	(OL)	Andrade,O	ONLINE
Targeted for Future Teachers but Open to all Students				
20124	3.0 HRS ARR	(OL)	Andrade,O	ONLINE
Targeted for Future Teachers but Open to all Students				
22182	3.0 HRS ARR	(OL)	Beck,A	ONLINE
Targeted for Future Teachers but Open to all Students				
27025	3.0 HRS ARR	(OL)	Gradin,S	ONLINE
27026	3.0 HRS ARR	(OL)	O'Neill,C	ONLINE
30055	3.0 HRS ARR	(OL)	Shah,S	ONLINE

Class# 30055 meets 08/22/2020-12/12/2020

#### CD 124 - 3.0 UNITS TEACHING IN A DIVERSE SOCIETY

Transferable to CSU

20661	3.0 HRS ARR	(OL)	Palma,J	ONLINE
22183	3.0 HRS ARR	(OL)	Palma,J	ONLINE

#### CD 139 - 3.0 UNITS OBSERVATION, ASSESSMENT, AND POSITIVE GUIDANCE OF CHILDHOOD

Transferable to CSU

Recommendation: CDEC 111 and CD 110 or equivalent with grades of Pass or "C" or higher.

20125	3.0 HRS ARR	(OL)	Gibson,D	ONLINE
21761	3.0 HRS ARR	(OL)	Gibson,D	ONLINE
29279	3.0 HRS ARR	(OL)	Beck,A	ONLINE

## CHILD DEVELOPMENT/EARLY CHILDHOOD

#### CDEC 111 - 3.0 UNITS PRINCIPLES AND PRACTICES IN EARLY CHILDHOOD EDUCATION

Transferable to CSU

20128	3.0 HRS ARR	(OL)	Ramirez,M	ONLINE
20127	3.0 HRS ARR	(OL)	Andrade,O	ONLINE
24178	3.0 HRS ARR	(OL)	Palma,J	ONLINE

Targeted for Future Teachers but Open to all Students

#### CDEC 112 - 3.0 UNITS INTRODUCTION TO CURRICULUM

Transferable to CSU

20665	3.0 HRS ARR	(OL)	Andrade,O	ONLINE
20130	3.0 HRS ARR	(OL)	Black,K	ONLINE
23803	3.0 HRS ARR	(OL)	Tharuvai,S	ONLINE

#### CDEC 113 - 3.0 UNITS THE CHILD, FAMILY, AND COMMUNITY

Transferable to CSU

23804	3.0 HRS ARR	(OL)	Palma,J	ONLINE
20132	3.0 HRS ARR	(OL)	Palma,J	ONLINE
21660	3.0 HRS ARR	(OL)	Beck,A	ONLINE

#### CDEC 161 - 3.0 UNITS HEALTH, SAFETY, AND NUTRITION

Transferable to CSU

20662	3.0 HRS ARR	(OL)	Sandoval,Y	ONLINE
22355	3.0 HRS ARR	(OL)	Beck,A	ONLINE

#### CDEC 164 - 3.0 UNITS PRACTICUM FIELD EXPERIENCE

Transferable to CSU

Prerequisite: CD 110, CDEC 111, CDEC 112, and CDEC 113 or equivalent with grades of Pass or "C" or higher. Recommendation: CD 124, CD 139, and CDEC 161.

<b>26164</b>	<b>6:00-7:50PM</b>	<b>T</b>	Ward,D	REMOTE
+ 3.0 HRS ARR			Ward,D	

#### CDEC 166 - 3.0 UNITS ADMINISTRATION I: PROGRAMS IN EARLY CHILDHOOD EDUCATION

Transferable to CSU

Prerequisite: CD 110, CDEC 111, CDEC 112, and CDEC 113 or equivalents with grades of "C" or higher or "Pass."

26168	3.0 HRS ARR	(OL)	Gradin,S	ONLINE
-------	-------------	------	----------	--------

#### CDEC 230 - 3.0 UNITS ADULT SUPERVISION AND MENTORING IN EARLY CARE AND EDUCATION

Transferable to CSU

Prerequisite: CD 110, CDEC 111, CDEC 112, and CDEC 113 or equivalents with grades of "C" or higher or "Pass."

20668	3.0 HRS ARR	(OL)	Gibson,D	ONLINE
-------	-------------	------	----------	--------

## CHILD DEVELOPMENT/INFANT TODDLER

#### CDIT 151 - 3.0 UNITS INFANT AND TODDLER DEVELOPMENT

Transferable to CSU

Recommendation: CD 110 or equivalent with a grade of Pass or "C" or higher.

20669	3.0 HRS ARR	(OL)	Gradin,S	ONLINE
-------	-------------	------	----------	--------

#### CDIT 152 - 3.0 UNITS CARE AND EDUCATION FOR INFANTS AND TODDLERS

Transferable to CSU

Recommendation: CD 110 and CDIT 151 or equivalent with grades of Pass or "C" or higher.

22833	3.0 HRS ARR	(OL)	Gradin,S	ONLINE
-------	-------------	------	----------	--------

## CHILD DEVELOPMENT/SPECIAL EDUCATION

#### CDSE 150 - 3.0 UNITS INTRODUCTION TO CHILDREN WITH SPECIAL NEEDS

Transferable to CSU

26166	3.0 HRS ARR	(OL)	Roberts,R	ONLINE
-------	-------------	------	-----------	--------

#### CDSE 152 - 3.0 UNITS CURRICULUM AND STRATEGIES FOR CHILDREN WITH SPECIAL NEEDS

Transferable to CSU

26167	3.0 HRS ARR	(OL)	STAFF	ONLINE
-------	-------------	------	-------	--------

## CHINESE

#### CHIN 101 - 5.0 UNITS ELEMENTARY CHINESE I

Transferable to UC, CSU

22601	12:30-2:45PM	TTh	Zhou,Y	(HYBRID)	REMOTE
+ 1.0 HRS ARR			Zhou,Y		REMOTE
LAB IS ONE HOUR PER WEEK I					
22603	12:30-2:45PM	MW	Zhou,Y	(HYBRID)	REMOTE
+ 1.0 HRS ARR			Zhou,Y		REMOTE
LAB IS ONE HOUR PER WEEK					

If a class displays as **REMOTE** in the schedule, students will be expected to log into the class at a specified day/time (e.g., MW 8-9:15am). If the class displays as **ONLINE** in the schedule, students are permitted to log into the class whenever they are available to complete coursework by the established deadlines.

Students not in attendance or late for the first class meeting are subject to drop.

Class#	Time	Day	Instructor	Room	Class#	Time	Day	Instructor	Room
<b>CHIN 102 - 5.0 UNITS ELEMENTARY CHINESE II</b>					29244 3.6 HRS ARR (OL) Forsythe,C ONLINE				
Transferable to UC, CSU					Mandatory Orientation: Instructor will contact students prior to class. Students give presentations and receive peer/faculty feedback via digital platforms.				
Prerequisite: CHIN 101 or equivalent with a grade of Pass or "C" or higher.					Class# 29244 meets 09/08/2020-12/18/2020				
23483	4:00-6:15PM	W	Zhou,Y (HYBRID)	REMOTE	20887	6.0 HRS ARR (OL)	Journey,J	REMOTE	ONLINE
+ 1.0 HRS ARR Zhou,Y REMOTE					Class# 20887 meets 08/17/2020-10/16/2020				
LAB IS ONE HOUR PER WEEK					29245 6.0 HRS ARR (OL) Wagner,H ONLINE				
<b>CHIN 201 - 5.0 UNITS INTERMEDIATE CHINESE I</b>					Mandatory Orientation: Instructor will contact students prior to class. Students give presentations and receive peer/faculty feedback via digital platforms.				
Transferable to UC, CSU					Class# 29245 meets 08/17/2020-10/16/2020				
Prerequisite: CHIN 102 or equivalent with a grade of "C" or higher of Pass					30189 6.0 HRS ARR (OL) Wagner,H ONLINE				
27077	4:00-6:15PM	Th	Zhou,Y (HYBRID)	REMOTE	Mandatory Orientation: Instructor will contact students prior to class. Students give presentations and receive peer/faculty feedback via digital platforms.				
+ 0.3 HRS ARR Zhou,Y REMOTE					Class# 30189 meets 10/19/2020-12/18/2020				
LAB IS ONE HOUR PER WEEK					24079 6.0 HRS ARR (OL) Journey,J ONLINE				
<b>CHIN 202 - 5.0 UNITS INTERMEDIATE CHINESE II</b>					Class# 24079 meets 10/19/2020-12/18/2020				
Transferable to UC, CSU					<b>COMM 103 - 3.0 UNITS ARGUMENTATION, PERSUASION, AND CRITICAL THINKING</b>				
Prerequisite: CHIN 201 or equivalent with a grade of "C" or higher or "Pass."					Transferable to UC, CSU (CAN SPCH 6)				
27079	4:00-6:15PM	Th	Zhou,Y (HYBRID)	REMOTE	Prerequisite: ENGL 100 or ENGL 100S or equivalent with a grade of "C" or "Pass" or higher.				
+ 0.3 HRS ARR Zhou,Y REMOTE					22149 9:30-10:45AM MW Sparks Jr.,W REMOTE				
LAB IS ONE HOUR PER WEEK					21658 3.0 HRS ARR (OL) Hernandez,W ONLINE				

## COMMUNICATION STUDIES

<b>COMM 60 - 3.0 UNITS BASICS OF SPEECH COMMUNICATION</b>				
Not Transferable				
29593	3.0 HRS ARR	(OL)	Forsythe,C	ONLINE
<b>COMM 100 - 3.0 UNITS INTRODUCTION TO COMMUNICATIONS STUDIES</b>				
Transferable to UC, CSU (CAN SPCH 2)				
Prerequisite: Completion of at least one of these courses with a grade of "C" or higher or "Pass" or an equivalent course: SPCH 60,ENGL 52, ENGL 72, ESL 152, READ 54, READ 97, or completion of the English or Reading Placement process.				
20571	11:00-12:15PM	TTh	Trickett,D	REMOTE
26984	3.0 HRS ARR	(OL)	Paek,J	ONLINE
20574	3.0 HRS ARR	(OL)	Carrell,K	ONLINE
20575	3.0 HRS ARR	(OL)	Gonzalez,R	ONLINE
20578	3.0 HRS ARR	(OL)	Montenegro,D	ONLINE
20579	3.0 HRS ARR	(OL)	Breit,C	ONLINE
20580	3.0 HRS ARR	(OL)	Nia,H	ONLINE
<b>21786</b>	<b>7:00-9:50PM</b>	<b>W</b>	Salim,F	REMOTE
21656	3.0 HRS ARR	(OL)	Hanniff,B	ONLINE
22279	3.0 HRS ARR	(OL)	Nia,H	ONLINE
<b>27082</b>	<b>7:00-9:50PM</b>	<b>M</b>	Salim,F	REMOTE
<b>26538</b>	<b>5:30-6:45PM</b>	<b>MW</b>	Salim,F	REMOTE
25973	3.0 HRS ARR	(OL)	Ayala,E	ONLINE
26507	3.0 HRS ARR	(OL)	Hanniff,B	ONLINE
26518	11:00-12:15PM	MW	Sparks Jr.,W	REMOTE
27305	8:00-9:15AM	MW	Sparks Jr.,W	REMOTE
27439	3.0 HRS ARR	(OL)	Michel,L	ONLINE
27451	3.0 HRS ARR	(OL)	Curva,A	ONLINE
27469	3.0 HRS ARR	(OL)	Ayala,E	ONLINE
27917	3.0 HRS ARR	(OL)	Ayala,E	ONLINE
27918	3:30- 4:45PM	TTh	Toomey,A	REMOTE
29246	3.0 HRS ARR	(OL)	Bracamontes,A	ONLINE
Mandatory Orientation: Instructor will contact students prior to class. Students give presentations and receive peer/faculty feedback via digital platforms.				
29352	3.0 HRS ARR	(OL)	Breit,C	ONLINE
29632	3.0 HRS ARR	(OL)	Lavariere,C	ONLINE
Mandatory Orientation: Instructor will contact students prior to class. Students give presentations and receive peer/faculty feedback via digital platforms.				
29633	3.0 HRS ARR	(OL)	Lavariere,C	ONLINE
Mandatory Orientation: Instructor will contact students prior to class. Students give presentations and receive peer/faculty feedback via digital platforms.				
29243	3.9 HRS ARR	(OL)	Nia,H	ONLINE
Class# 29243 meets 09/12/2020-12/12/2020				
30190	3.6 HRS ARR	(OL)	Arvilla Bohmer,E	ONLINE
Class# 30190 meets 09/08/2020-12/18/2020				
30191	3.6 HRS ARR	(OL)	Arvilla Bohmer,E	ONLINE
Class# 30191 meets 09/08/2020-12/18/2020				
27468	3.6 HRS ARR	(OL)	Hanniff,B	ONLINE
Mandatory Orientation: Instructor will contact students prior to class. Students give presentations and receive peer/faculty feedback via digital platforms.				
Class# 27468 meets 09/08/2020-12/18/2020				

<b>COMM 103 - 3.0 UNITS ARGUMENTATION, PERSUASION, AND CRITICAL THINKING</b>				
Transferable to UC, CSU (CAN SPCH 6)				
Prerequisite: ENGL 100 or ENGL 100S or equivalent with a grade of "C" or "Pass" or higher.				
22149	9:30-10:45AM	MW	Sparks Jr.,W	REMOTE
21658	3.0 HRS ARR	(OL)	Hernandez,W	ONLINE
20590	9:30-10:45AM	TTh	Trickett,D	REMOTE
26988	3.6 HRS ARR	(OL)	Navarro,M	ONLINE
Class# 26988 meets 09/08/2020-12/18/2020				
24624	3.6 HRS ARR	(OL)	Matthews,N	ONLINE
Class# 24624 meets 09/08/2020-12/17/2020				
<b>COMM 110 - 3.0 UNITS INTERCULTURAL COMMUNICATION</b>				
Transferable to UC, CSU				
Prerequisite: Completion of at least one of these courses with a grade of "C" or higher or "Pass" or an equivalent course: SPCH 60, ENGL 52, ESL 152, READ 54, READ 97, or completion of the English or Reading placement process.				
25057	2:00-3:15PM	TTh	Toomey,A	REMOTE
20581	9:30-11:00AM	Th	Cravalho,A	REMOTE
Class# 20581 meets 09/08/2020-12/17/2020				
25632	6.0 HRS ARR	(OL)	Hoppe-Nagao,A	ONLINE
Mandatory Orientation: Instructor will contact students prior to class. Students give presentations and receive peer/faculty feedback via digital platforms.				
Class# 25632 meets 08/17/2020-10/16/2020				
25633	6.0 HRS ARR	(OL)	Benitez-Whitney,M	ONLINE
Mandatory Orientation: Instructor will contact students prior to class. Students give presentations and receive peer/faculty feedback via digital platforms.				
Class# 25633 meets 10/19/2020-12/18/2020				
<b>COMM 115 - 3.0 UNITS GENDER, COMMUNICATION, AND THE DIGITAL REVOLUTION</b>				
Transferable to CSU				
Prerequisite: Completion of at least one of these courses: COMM 60, ENGL 52, ENGL 72,ESL 152,READ 54,READ 97 or completion of the English or Reading placement/assessment process with eligibility for ENGL 100 or ENGL 100S.				
29249	6.0 HRS ARR	(OL)	Rosenfeld,K	ONLINE
Mandatory Orientation: Instructor will contact students prior to class. Students give presentations and receive peer/faculty feedback via digital platforms.				
Class# 29249 meets 08/17/2020-10/16/2020				
28151	6.0 HRS ARR	(OL)	Rosenfeld,K	ONLINE
Mandatory Orientation: Instructor will contact students prior to class. Students give presentations and receive peer/faculty feedback via digital platforms.				
Class# 28151 meets 10/19/2020-12/18/2020				
<b>COMM 120 - 3.0 UNITS INTERPERSONAL COMMUNICATION</b>				
Transferable to CSU				
Prerequisite: Completion of at least one of these courses: COMM 60, ENGL 52, ENGL 72,ESL 152,READ 54,READ 97 or completion of the English or Reading placement/assessment process with eligibility for ENGL 100 or ENGL 100S.				
20582	3.0 HRS ARR	(OL)	STAFF	ONLINE
Mandatory Orientation: Instructor will contact students prior to class. Students give presentations and receive peer/faculty feedback via digital platforms.				
21864	12:30-1:45PM	TTh	Toomey,A	REMOTE
20583	3.0 HRS ARR	(OL)	Wagner,H	ONLINE
30193	3.0 HRS ARR	(OL)	Hanniff,B	ONLINE
25059	3.0 HRS ARR	(OL)	Curva,A	ONLINE
23936	8:00-9:15AM	TTh	Benitez-Whitney,M	REMOTE
27083	3.0 HRS ARR	(OL)	Hoppe-Nagao,A	ONLINE
29251	3.0 HRS ARR	(OL)	Hanniff,B	ONLINE

If a class displays as **REMOTE** in the schedule, students will be expected to log into the class at a specified day/time (e.g., MW 8-9:15am). If the class displays as **ONLINE** in the schedule, students are permitted to log into the class whenever they are available to complete coursework by the established deadlines.

Students not in attendance or late for the first class meeting are subject to drop.

Class#	Time	Day	Instructor	Room	Class#	Time	Day	Instructor	Room
--------	------	-----	------------	------	--------	------	-----	------------	------

**COMM 125 - 3.0 UNITS ORGANIZATIONAL COMMUNICATION**

Transferable to CSU  
 Recommendation: Suggested completion of at least one of these courses with a grade of "C" or higher or "Pass" or an equivalent course: ENGL 72, or ESL 152, or READ 54, or READ 97, or completion of the English, r ESL or Reading placement/assessment process with eligibility for ENGL 100.

23507	3.0 HRS ARR	(OL)	Paek,J	ONLINE
27919	3.0 HRS ARR	(OL)	Hernandez,W	ONLINE

**COMM 130 - 3.0 UNITS PUBLIC SPEAKING**

Transferable to UC, CSU (CAN SPCH 4)  
 Prerequisite: Completion of at least one of these courses course:COMM 60, ENGL 52, ENGL72,ESL 152,READ 54,READ 97 or completion of the English or Reading placement/assessment process with eligibility for ENGL 100 or ENGL 100S.

21866	3.0 HRS ARR	(OL)	Hernandez,W	ONLINE
20584	12:30- 1:45PM	TTh	Crvalho,A	REMOTE
20586	3.0 HRS ARR	(OL)	Matthews,N	ONLINE
21463	3.0 HRS ARR	(OL)	Carrell,K	ONLINE
23938	3.0 HRS ARR	(OL)	Hanniff,B	ONLINE
23937	3.0 HRS ARR	(OL)	Dejean,A	ONLINE
25976	3.0 HRS ARR	(OL)	Eldridge Jr.,A	ONLINE
22411	3.0 HRS ARR	(OL)	Forsythe,C	ONLINE
28407	3.0 HRS ARR	(OL)	Michel,L	ONLINE
29252	3.0 HRS ARR	(OL)	Dejean,A	ONLINE
24619	3.6 HRS ARR	(OL)	Morones,D	ONLINE

Targeted for Future Teachers but Open to All Students  
 Class# 24619 meets 09/08/2020-12/18/2020

30194	6.0 HRS ARR	(OL)	Aguirre,S	ONLINE
29254	6.0 HRS ARR	(OL)	Aguirre,S	ONLINE

Class# 30194 meets 08/17/2020-10/16/2020  
 Class# 29254 meets 10/19/2020-12/18/2020

**COMM 132 - 3.0 UNITS SMALL GROUP COMMUNICATION**

Transferable to UC, CSU (CAN SPCH 10)  
 Prerequisite: Completion of at least one of these courses: COMM 60, ENGL 52, ENGL 72,ESL 152,READ 54,READ 97 or completion of the English or Reading placement/assessment process with eligibility for ENGL 100 or ENGL 100S.

21657	3.0 HRS ARR	(OL)	Carrell,K	ONLINE
26315	3.0 HRS ARR	(OL)	Judy,R	ONLINE

**COMM 140 - 3.0 UNITS ORAL INTERPRETATION OF LITERATURE**

Transferable to UC, CSU  
 Prerequisite: Completion of at least one of these courses with a grade of "C" or higher or "Pass" or an equivalent course:COMM 60,ENGL 52,ENGL72,ESL 152,READ 54,READ 97 or completion of the English or Reading placement/assessment process with eligibility for ENGL 100.

24622	3.6 HRS ARR	(OL)	Gonzalez,R	ONLINE
-------	-------------	------	------------	--------

Class# 24622 meets 09/08/2020-12/18/2020

**COMM 145 - 3.0 UNITS STORYTELLING**

Transferable to CSU  
 30195 3.6 HRS ARR (OL) Navarro,M ONLINE  
 Class# 30195 meets 09/08/2020-12/18/2020

**COMM 200 - 3.0 UNITS CONTEMPORARY COMMUNICATION TOPICS**

Transferable to CSU  
 Recommendation: Suggested completion of at least one of these courses with a grade of "C" or higher or "Pass" or an equivalent course: ENGL 72, or ESL 152, or READ 54, or READ 97, or completion of the English, or ESL or Reading assessment/assessment process with eligibility for ENGL 100 or ENGL 100S.  
 24623 6.0 HRS ARR (OL) Rosenfeld,K ONLINE  
 Mandatory Orientation: Instructor will contact students prior to class. Students give presentations and receive peer/faculty feedback via digital platforms.  
 Class# 24623 meets 10/19/2020-12/18/2020

**COMM 231 - 1.0 UNIT FORENSICS ACTIVITY 1 (COMPETITIVE SPEECH AND DEBATE)**

Transferable to CSU  
 27190 1.0 HRS ARR (OL) Aguirre,S REMOTE  
 Class will meet Tuesday and Thursday at 4:00-5:30 p.m.  
 Class# 27190 meets 08/17/2020-12/18/2020

**COMM 232 - 2.0 UNITS FORENSICS ACTIVITY 2 (COMPETITIVE SPEECH AND DEBATE)**

Transferable to CSU  
 27191 2.0 HRS ARR (OL) Aguirre,S REMOTE  
 Class will meet Tuesday and Thursday at 4:00-5:30 p.m.  
 Class# 27191 meets 08/17/2020-12/18/2020

**COMM 233 - 3.0 UNITS FORENSICS ACTIVITY 3 (COMPETITIVE SPEECH AND DEBATE)**

Transferable to CSU  
 30196 3.0 HRS ARR (OL) Gonzalez,R REMOTE  
 Class will meet Tuesday and Thursday at 4:00-5:30 p.m.  
 Class# 30196 meets 08/17/2020-12/18/2020

**COMPUTER AND INFORMATION SCIENCES**

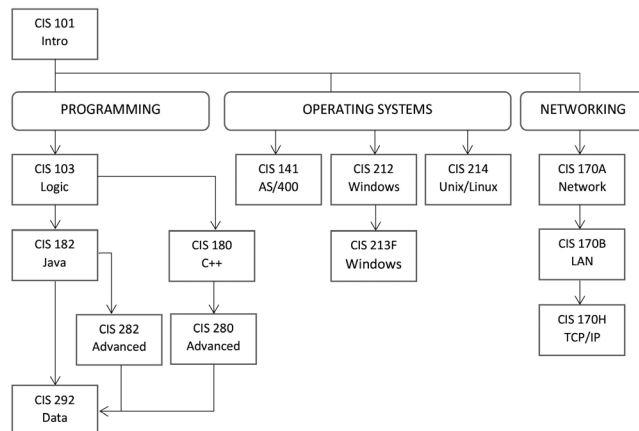

**Insert Above CIS 58A:**

**To Prepare for the CompTIA A+ Certification**

Take the following courses:  
 CIS 102 Intro Micrcomp Hdwrr Sfwrr  
 CIS 58A PC Operating System A+ Certification  
 CIS 58B PC Core Hardware A+ Certification  
 For more information, contact:  
 Kenny Lou at [klou@cerritos.edu](mailto:klou@cerritos.edu) or  
 Gene LaZor at [glazor@cerritos.edu](mailto:glazor@cerritos.edu)

**CIS 58A - 3.5 UNITS PC OPERATING SYSTEM A+ CERTIFICATION**

Not Transferable  
 Recommendation: CIS 101 or CIS 102 or equivalent with a grade of "C" or higher or "Pass" or appropriate work experience.  
 27672 6.0 HRS ARR (OL) Lazor,C ONLINE  
 + 4.0 HRS ARR (OL) Lazor,C ONLINE  
 Note: The course orientation will be online. The instructor will contact you with orientation information. Please check Canvas and your email for updates.  
 Class# 27672 meets 08/17/2020-10/16/2020

**CIS 58B - 3.5 UNITS PC CORE HARDWARE A+ CERTIFICATION**

Not Transferable  
 Recommendation: CIS 101 or CIS 102 or equivalent with a grade of "C" or higher or "Pass" or appropriate work experience.  
 29361 6.0 HRS ARR (OL) Lazor,C ONLINE  
 + 4.0 HRS ARR (OL) Lazor,C ONLINE  
 Note: The course orientation will be online. The instructor will contact you with orientation information. Please check Canvas and your email for updates.  
 Class# 29361 meets 10/19/2020-12/18/2020

If a class displays as **REMOTE** in the schedule, students will be expected to log into the class at a specified day/time (e.g., MW 8-9:15am). If the class displays as **ONLINE** in the schedule, students are permitted to log into the class whenever they are available to complete coursework by the established deadlines.

Students not in attendance or late for the first class meeting are subject to drop.

Class#	Time	Day	Instructor	Room	Class#	Time	Day	Instructor	Room
<b>CIS 101 - 3.0 UNITS INTRODUCTION TO COMPUTER INFORMATION SYSTEMS</b>					<b>CIS 155 - 3.0 UNITS MICROSOFT ACCESS</b>				
Transferable to UC, CSU (CAN BUS 6)					Transferable to CSU				
Recommendation: CIS 102 or equivalent with a grade of Pass or "C" or higher.					Recommendation: CIS 102 or equivalent with a grade of Pass or "C" or higher.				
20138	3.0 HRS ARR	(OL)	Woolever,J	ONLINE	26885	3.6 HRS ARR	(OL)	Whitney,D	ONLINE
	+ 1.0 HRS ARR	(OL)	Woolever,J	ONLINE		+ 2.4 HRS ARR	(OL)	Whitney,D	ONLINE
Note: The course orientation will be online. The instructor will contact you with orientation information. Please check Canvas and your email for updates.					Note: The course orientation will be online. The instructor will contact you with orientation information. Please check Canvas and your email for updates.				
Class# 26885 meets 09/08/2020-12/18/2020									
20141	3.0 HRS ARR	(OL)	Konefsky,B	ONLINE	<b>CIS 160 - 3.5 UNITS WEB PAGE DEVELOPMENT</b>				
	+ 1.0 HRS ARR	(OL)	Konefsky,B	ONLINE	Transferable to CSU				
Note: The course orientation will be online. The instructor will contact you with orientation information. Please check Canvas and your email for updates.					26889				
20145	3.0 HRS ARR	(OL)	Alavian,M	ONLINE		3.0 HRS ARR	(OL)	Huynh,H	ONLINE
	+ 1.0 HRS ARR	(OL)	Alavian,M	ONLINE		+ 2.0 HRS ARR	(OL)	Huynh,H	ONLINE
Note: The course orientation will be online. The instructor will contact you with orientation information. Please check Canvas and your email for updates.					Note: The course orientation will be online. The instructor will contact you with orientation information. Please check Canvas and your email for updates.				
26877	3.0 HRS ARR	(OL)	Lazor,C	ONLINE	<b>CIS 162 - 3.5 UNITS HTML AND CSS</b>				
	+ 1.0 HRS ARR	(OL)	Lazor,C	ONLINE	Transferable to CSU				
Note: The course orientation will be online. The instructor will contact you with orientation information. Please check Canvas and your email for updates.					Recommendation: CIS 101 or CIS 102 or equivalent with a grade of "C" or higher or "Pass."				
23987	3.6 HRS ARR	(OL)	Laredo,N	ONLINE	24321	3.0 HRS ARR	(OL)	Lazor,C	ONLINE
	+ 1.2 HRS ARR	(OL)	Laredo,N	ONLINE		+ 2.0 HRS ARR	(OL)	Lazor,C	ONLINE
Note: The course orientation will be online. The instructor will contact you with orientation information. Please check Canvas and your email for updates.					Note: The course orientation will be online. The instructor will contact you with orientation information. Please check Canvas and your email for updates.				
Class# 23987 meets 09/08/2020-12/18/2020					<b>CIS 170A - 3.5 UNITS NETWORKING FUNDAMENTALS</b>				
20673	6.0 HRS ARR	(OL)	Davis,R	ONLINE	Transferable to CSU				
	+ 2.0 HRS ARR	(OL)	Davis,R	ONLINE	24307	6.0 HRS ARR	(OL)	Lou,Z	ONLINE
Note: The course orientation will be online. The instructor will contact you with orientation information. Please check Canvas and your email for updates.					+ 4.0 HRS ARR (OL) Lou,Z ONLINE				
Class# 20673 meets 08/17/2020-10/16/2020					Mandatory Orientation: See website <a href="http://www.cerritos.edu/klou">http://www.cerritos.edu/klou</a> or email to <a href="mailto:klou@cerritos.edu">klou@cerritos.edu</a> for orientation instructions				
29800	6.0 HRS ARR	(OL)	Ford,B	ONLINE	Class# 24307 meets 08/17/2020-10/16/2020				
	+ 2.0 HRS ARR	(OL)	Ford,B	ONLINE	<b>CIS 170B - 3.5 UNITS NETWORK + CERTIFICATION</b>				
Note: The course orientation will be online. The instructor will contact you with orientation information. Please check Canvas and your email for updates.					Transferable to CSU				
Class# 29800 meets 10/19/2020-12/18/2020					24311	3.6 HRS ARR	(OL)	Lou,Z	ONLINE
						+ 2.4 HRS ARR	(OL)	Lou,Z	ONLINE
					Mandatory Orientation: See website <a href="http://www.cerritos.edu/klou">http://www.cerritos.edu/klou</a> or email to <a href="mailto:klou@cerritos.edu">klou@cerritos.edu</a> for orientation instructions				
					Class# 24311 meets 09/08/2020-12/18/2020				
<b>CIS 102 - 3.0 UNITS INTRODUCTION TO MICROCOMPUTER HARDWARE AND APPLICATIONS SOFT</b>					<b>CIS 170E - 3.5 UNITS ROUTER CONFIGURATIONS AND PROTOCOL</b>				
Transferable to UC, CSU					Transferable to CSU				
Recommendation: Concurrent enrollment in or completion of CIS 101 or CIS 102 or equivalent with a grade of "C" or higher or "Pass."					Prerequisite: CIS 170A (formerly CIS 70A) or equivalent with a grade of "C" or higher or "Pass" or appropriate work experience.				
20674	3.0 HRS ARR	(OL)	Nance,W	ONLINE	24313	3.0 HRS ARR	(OL)	Lazor,C	ONLINE
See website <a href="http://www.cerritos.edu/nance">http://www.cerritos.edu/nance</a> for orientation document and quiz due 8/17/20.						+ 2.0 HRS ARR	(OL)	Lazor,C	ONLINE
	+ 2.0 HRS ARR	(OL)	Nance,W	ONLINE	Note: The course orientation will be online. The instructor will contact you with orientation information. Please check Canvas and your email for updates.				
<b>CIS 103 - 3.5 UNITS COMPUTER PROGRAMMING LOGIC</b>					<b>CIS 170F - 3.5 UNITS ADVANCED SWITCHING AND ROUTING</b>				
Transferable to UC, CSU					Transferable to CSU				
Recommendation: Concurrent enrollment in or completion of CIS 101 or CIS 102 or equivalent with a grade of "C" or higher or "Pass."					Prerequisite: CIS 170E (formerly CIS 70E) or equivalent with a grade of "C" or higher or "Pass" or appropriate work experience.				
24104	3.0 HRS ARR	(OL)	Nguyen,P	ONLINE	24315	3.0 HRS ARR	(OL)	Lazor,C	ONLINE
	+ 2.0 HRS ARR	(OL)	Nguyen,P	ONLINE		+ 2.0 HRS ARR	(OL)	Lazor,C	ONLINE
Note: The course orientation will be online. The instructor will contact you with orientation information. Please check Canvas and your email for updates.					Note: The course orientation will be online. The instructor will contact you with orientation information. Please check Canvas and your email for updates.				
20147	3.0 HRS ARR	(OL)	Nguyen,P	ONLINE	<b>CIS 170G - 3.5 UNITS WIDE AREA NETWORKS</b>				
	+ 2.0 HRS ARR	(OL)	Nguyen,P	ONLINE	Transferable to CSU				
Note: The course orientation will be online. The instructor will contact you with orientation information. Please check Canvas and your email for updates.					Prerequisite: CIS 170E (formerly CIS 70E) or equivalent with a grade of "C" or higher or "Pass" or appropriate work experience.				
20676	3.0 HRS ARR	(OL)	Nguyen,P	ONLINE	24317	3.0 HRS ARR	(OL)	Lazor,C	ONLINE
	+ 2.0 HRS ARR	(OL)	Nguyen,P	ONLINE		+ 2.0 HRS ARR	(OL)	Lazor,C	ONLINE
Note: The course orientation will be online. The instructor will contact you with orientation information. Please check Canvas and your email for updates.					Note: The course orientation will be online. The instructor will contact you with orientation information. Please check Canvas and your email for updates.				
27962	3.0 HRS ARR	(OL)	Mellas,D	ONLINE	<b>CIS 170H - 3.0 UNITS TCP/IP FUNDAMENTALS</b>				
	+ 2.0 HRS ARR	(OL)	Mellas,D	ONLINE	Transferable to CSU				
Note: The course orientation will be online. The instructor will contact you with orientation information. Please check Canvas and your email for updates.					Recommendation: A knowledge of Web browser and e-mail applications.				
25183	3.6 HRS ARR	(OL)	James,J	ONLINE	26367	6.0 HRS ARR	(OL)	Lou,Z	ONLINE
	+ 2.4 HRS ARR	(OL)	James,J	ONLINE	Note: See website <a href="http://www.cerritos.edu/klou">http://www.cerritos.edu/klou</a> or email to <a href="mailto:klou@cerritos.edu">klou@cerritos.edu</a> for orientation instructions.				
Note: The course orientation will be online. The instructor will contact you with orientation information. Please check Canvas and your email for updates.					Class# 26367 meets 10/19/2020-12/18/2020				
Class# 25183 meets 09/08/2020-12/18/2020									
<b>CIS 151 - 3.5 UNITS MICROSOFT EXCEL FOR INFORMATION SYSTEMS/INFORMATION TECHNOLOGY</b>									
Transferable to CSU									
28997	3.6 HRS ARR	(OL)	Whitney,D	ONLINE					
	+ 2.4 HRS ARR	(OL)	Whitney,D	ONLINE					
Note: The course orientation will be online. The instructor will contact you with orientation information. Please check Canvas and your email for updates.									
Class# 28997 meets 09/08/2020-12/18/2020									

If a class displays as **REMOTE** in the schedule, students will be expected to log into the class at a specified day/time (e.g., MW 8-9:15am). If the class displays as **ONLINE** in the schedule, students are permitted to log into the class whenever they are available to complete coursework by the established deadlines.

Students not in attendance or late for the first class meeting are subject to drop.

Class#	Time	Day	Instructor	Room	Class#	Time	Day	Instructor	Room
<b>CIS 170I - 3.5 UNITS CISCO NETWORK SECURITY</b> Transferable to CSU Recommendation: A knowledge of Cisco Internet Operating Systems (IOS) or appropriate work experience.					<b>CIS 214 - 3.0 UNITS UNIX AND LINUX OPERATING SYSTEMS</b> Transferable to CSU Recommendation: Knowledge of one operating system.				
29001	3.6 HRS ARR + 2.4 HRS ARR	(OL) (OL)	Dellaca,R Dellaca,R	ONLINE ONLINE	20679	3.0 HRS ARR + 2.0 HRS ARR	(OL) (OL)	Mellas,D Mellas,D	ONLINE ONLINE
Note: The course orientation will be online. The instructor will contact you with orientation information. Please check Canvas and your email for updates. Class# 29001 meets 09/08/2020-12/18/2020					Note: The course orientation will be online. The instructor will contact you with orientation information. Please check Canvas and your email for updates.				
<b>CIS 170L - 3.5 UNITS CYBERSECURITY FUNDAMENTALS</b> Transferable to CSU					<b>CIS 231 - 3.5 UNITS COMPUTER ORGANIZATION AND ASSEMBLY LANGUAGE PROGRAMMING</b> Transferable to UC, CSU Prerequisite: CIS 180 or CIS 182 or CIS 183 or equivalent with a grade of "C" or higher or "Pass."				
24305	3.0 HRS ARR + 2.0 HRS ARR	(OL) (OL)	Lou,Z Lou,Z	ONLINE ONLINE	30202	3.0 HRS ARR + 2.0 HRS ARR	(OL) (OL)	Nachawati,S Nachawati,S	ONLINE ONLINE
See website <a href="http://www.cerritos.edu/klou">http://www.cerritos.edu/klou</a> or email to <a href="mailto:klou@cerritos.edu">klou@cerritos.edu</a> for orientation instructions.					Note: The course orientation will be online. The instructor will contact you with orientation information. Please check Canvas and your email for updates.				
<b>CIS 171A - 3.0 UNITS INTRODUCTION TO CLOUD COMPUTING</b> Transferable to CSU					<b>CIS 280X - 3.5 UNITS OBJECT-ORIENTED PROGRAMMING IN C++</b> Transferable to CSU Recommendation: Strongly recommend CIS 180 or equivalent with a grade of Pass or "C" or higher.				
30630	3.0 HRS ARR + 1.0 HRS ARR	(OL) (OL)	Lou,Z Lou,Z	ONLINE ONLINE	29003	3.0 HRS ARR + 2.0 HRS ARR	(OL) (OL)	Nachawati,S Nachawati,S	ONLINE ONLINE
See website <a href="http://www.cerritos.edu/klou">http://www.cerritos.edu/klou</a> or email <a href="mailto:klou@cerritos.edu">klou@cerritos.edu</a> for mandatory orientation instructions.					Note: The course orientation will be online. The instructor will contact you with orientation information. Please check Canvas and your email for updates.				
<b>CIS 180 - 3.0 UNITS PROGRAMMING IN C/C++</b> Transferable to UC, CSU Prerequisite: CIS 103 or equivalent with a grade of "C" or higher or "Pass."					<b>CIS 288 - 3.5 UNITS MOBILE APPLICATION DEVELOPMENT</b> Transferable to CSU Recommendation: Knowledge of one object-oriented programming language (such as C++, Java, or C#) or related work experience.				
21448	3.0 HRS ARR + 2.0 HRS ARR	(OL) (OL)	Nguyen,P Nguyen,P	ONLINE ONLINE	24331	3.0 HRS ARR + 2.0 HRS ARR	(OL) (OL)	Huynh,H Huynh,H	ONLINE ONLINE
Note: The course orientation will be online. The instructor will contact you with orientation information. Please check Canvas and your email for updates.					Note: The course orientation will be online. The instructor will contact you with orientation information. Please check Canvas and your email for updates.				
29712	3.6 HRS ARR + 2.4 HRS ARR	(OL) (OL)	Tilak,N Tilak,N	ONLINE ONLINE					
Note: The course orientation will be online. The instructor will contact you with orientation information. Please check Canvas and your email for updates. Class# 29712 meets 09/08/2020-12/18/2020					<b>CIS 292 - 3.0 UNITS DATA STRUCTURES</b> Transferable to UC, CSU Prerequisite: CIS 183 or CIS 280X or equivalent of either course with a grade of "C" or higher or "Pass" or appropriate work experience.				
<b>CIS 183 - 3.0 UNITS JAVA PROGRAMMING</b> Transferable to CSU Prerequisite: CIS 103 or equivalent with a grade of "C" or higher or "Pass."					27686 3.0 HRS ARR (OL) Mellas,D ONLINE Note: The course orientation will be online. The instructor will contact you with orientation information. Please check Canvas and your email for updates.				
25716	3.0 HRS ARR + 2.0 HRS ARR	(OL) (OL)	Wolde,E Wolde,E	ONLINE ONLINE					
Note: The course orientation will be online. The instructor will contact you with orientation information. Please check Canvas and your email for updates.									
25718	3.0 HRS ARR + 2.0 HRS ARR	(OL) (OL)	Mellas,D Mellas,D	ONLINE ONLINE					
Note: The course orientation will be online. The instructor will contact you with orientation information. Please check Canvas and your email for updates.									
<b>CIS 185 - 3.0 UNITS DISCRETE STRUCTURES</b> Transferable to UC, CSU Prerequisite: CIS 183 or equivalent with a grade of "C" or higher or "Pass."									
26365	3.0 HRS ARR + 1.0 HRS ARR	(OL) (OL)	Nguyen,M Nguyen,M	ONLINE ONLINE					
Note: The course orientation will be online. The instructor will contact you with orientation information. Please check Canvas and your email for updates.									
<b>CIS 212 - 3.5 UNITS INTRODUCTION TO MICROSOFT WINDOWS ADMINISTRATION</b> Transferable to CSU Recommendation: CIS 58A or equivalent with a grade of "C" or higher or "Pass."									
28282	3.6 HRS ARR + 2.4 HRS ARR	(OL) (OL)	Dellaca,R Dellaca,R	ONLINE ONLINE					
Note: The course orientation will be online. The instructor will contact you with orientation information. Please check Canvas and your email for updates. Class# 28282 meets 09/08/2020-12/18/2020									
<b>CIS 213F - 3.5 UNITS MICROSOFT WINDOWS SERVER ADMINISTRATION</b> Transferable to CSU									
28737	3.6 HRS ARR + 2.4 HRS ARR	(OL) (OL)	Dellaca,R Dellaca,R	ONLINE ONLINE					
Note: The course orientation will be online. The instructor will contact you with orientation information. Please check Canvas and your email for updates. Class# 28737 meets 09/08/2020-12/18/2020									
<b>COSMETOLOGY</b>									
<b>COS 53 - 7.5 UNITS ADVANCED COSMETOLOGY MANIPULATION</b> Not Transferable Prerequisite: COS62B or COS 70C with a grade of "C" or higher or "Pass". Please read the technical standards relevant to this department at <a href="http://cms.cerritos.edu/technology/standards.htm">http://cms.cerritos.edu/technology/standards.htm</a>					<b>COS 54 - 11.0 UNITS INTRODUCTORY ESTHETICIAN</b> Not Transferable Prerequisite: ENGL 100 or ENGL 100S or equivalent with a grade of "C" or higher or "Pass" and READ 54 or READ 97 or equivalent with a grade of "C" or higher or "Pass" or completion of the Reading placement process with eligibility for "Reading Exempt."				
27128 8:00-10:10AM WThF Petrova,R REMOTE 10:10-5:10PM WThF Petrova,R REMOTE Class# 27128 meets 08/17/2020-10/16/2020					24231 8:00-10:25AM MTW Petrova,R REMOTE 10:25- 4:20PM MT Petrova,R REMOTE Class# 24231 meets 09/08/2020-12/18/2020				
<b>COS 54A - 11.0 UNITS ADVANCED ESTHETICIAN</b> Not Transferable Prerequisite: COS 54 or equivalent with a grade of Pass or "C" or higher. NOTE: a material fee of \$50.00 is required for COS 54A					27607 8:00-10:30AM WThF Ramirez-Han,J REMOTE 10:30-4:30PM WThF Ramirez-Han,J HS201 The lab portion of this class will be a hybrid - partially on campus & partially online. The class will be divided into two groups. Each group will be on campus partially. You will be contacted by your instructor on which group you will be assigned to. Class# 27607 meets 08/17/2020-11/27/2020				

If a class displays as **REMOTE** in the schedule, students will be expected to log into the class at a specified day/time (e.g., MW 8-9:15am). If the class displays as **ONLINE** in the schedule, students are permitted to log into the class whenever they are available to complete coursework by the established deadlines.

Students not in attendance or late for the first class meeting are subject to drop.

Class#	Time	Day	Instructor	Room	Class#	Time	Day	Instructor	Room
<b>COS 55 - 6.5 UNITS ESTHETICS CROSSOVER</b> Not Transferable Prerequisite: ENGL 100 or ENGL 100S or equivalent; and COS 61B; and READ 54 or READ 97 or equivalent with a grade of "C" or higher or "Pass" or a cosmetology license or proof of completion of a cosmetology program.					COUNSELING				
30002	8:00-10:20AM 10:20- 5:05PM	MTW MTW	Petrova,R Petrova,R	REMOTE REMOTE	29069	2:00- 3:50PM	T	Lee,R	REMOTE
Class# 30002 meets 10/19/2020-12/18/2020					NOTE: a material fee of \$28.00 is required for COUN 10 Class# 29069 meets 10/20/2020-12/15/2020				
<b>COS 60A - 11.0 UNITS INTRODUCTORY COSMETOLOGY I</b> Not Transferable Prerequisite: ENGL 100 or ENGL 100S or equivalent and READ 54 or READ 97 or READ 102 or equivalent with a grade of "C" or higher or "Pass" or completion of the English/Reading assessment/placement process.					<b>COUN 101A - 0.5 UNIT ORIENTATION TO COLLEGE</b> Transferable to CSU				
22217	8:00-10:25AM 10:25- 4:20PM	MTWThF MTWThF	Smith,F Smith,F	REMOTE REMOTE	29277	9:30-10:45AM	W	Hernandez-Garcia,N	REMOTE
Class# 22217 meets 08/17/2020-10/16/2020					Class# 29277 meets 09/30/2020-11/04/2020 <b>23681 5:00- 6:15PM Th</b> Class# 23681 meets 10/01/2020-11/05/2020 Wang,L				
<b>COS 60B - 11.0 UNITS INTRODUCTORY COSMETOLOGY II</b> Not Transferable Prerequisite: COS 60A with a grade of "C" or higher or "Pass".					<b>COUN 101B - 0.5 UNIT EDUCATIONAL PLANNING</b> Transferable to CSU				
22219	8:00-10:30AM 10:30- 4:50PM	MTWThF MTWThF	Smith,F Smith,F	REMOTE REMOTE	30498	9:00-10:15AM	MW	Hernandez,M	REMOTE
Class# 22219 meets 10/19/2020-12/18/2020					Class# 30498 meets 08/17/2020-09/02/2020 Class# 30504 meets 08/17/2020-09/02/2020 Class# 30514 meets 09/11/2020-09/25/2020 Class# 30518 meets 09/11/2020-09/25/2020 Class# 30522 meets 09/11/2020-09/25/2020 Class# 30499 meets 08/18/2020-09/03/2020 Class# 30500 meets 08/18/2020-09/03/2020 Class# 30527 meets 08/22/2020-09/05/2020 Class# 30515 meets 10/02/2020-10/16/2020 Class# 30519 meets 10/02/2020-10/16/2020 Class# 30523 meets 10/02/2020-10/16/2020 Class# 30525 meets 10/02/2020-10/16/2020				
<b>COS 61A - 11.0 UNITS INTERMEDIATE COSMETOLOGY I</b> Not Transferable Prerequisite: COS 60B with a grade of "C" or higher or "Pass".					<b>30507 5:00- 7:50PM M</b> Class# 30507 meets 08/17/2020-08/31/2020 Quilizapa,C				
22221	8:00-10:25AM 10:25-4:20PM	MTWThF MTWThF	Motruk,N Motruk,N	REMOTE HS204	30513	9:00-11:50AM	F	Walsh,M	REMOTE
The lab portion of this class will be a hybrid - partially on campus & partially online. The class will be divided into two groups. Each group will be on campus partially. You will be contacted by your instructor on which group you will be assigned to. Class# 22221 meets 08/17/2020-10/16/2020					Class# 30513 meets 08/21/2020-09/04/2020 Class# 30517 meets 08/21/2020-09/04/2020 Class# 30521 meets 08/21/2020-09/04/2020 Class# 30501 meets 09/08/2020-09/24/2020 Class# 30528 meets 09/12/2020-09/26/2020 Class# 30516 meets 10/23/2020-11/06/2020 Class# 30520 meets 10/23/2020-11/06/2020 Class# 30524 meets 10/23/2020-11/06/2020 Class# 30526 meets 10/23/2020-11/06/2020				
<b>COS 61B - 11.0 UNITS INTERMEDIATE COSMETOLOGY II</b> Not Transferable Prerequisite: COS 61A with a grade of "C" or higher or "Pass".					<b>30517 9:00-11:50AM F</b> Class# 30517 meets 08/21/2020-09/04/2020 Hernandez,M				
22223	8:00-10:30AM 10:30- 4:50PM	MTWThF MTWThF	Motruk,N Motruk,N	REMOTE HS204	30521	12:00- 2:50PM	F	STAFF	REMOTE
The lab portion of this class will be a hybrid - partially on campus & partially online. The class will be divided into two groups. Each group will be on campus partially. You will be contacted by your instructor on which group you will be assigned to. Class# 22223 meets 10/19/2020-12/18/2020					Class# 30521 meets 08/21/2020-09/04/2020 Class# 30501 meets 09/08/2020-09/24/2020 Class# 30528 meets 09/12/2020-09/26/2020 Class# 30516 meets 10/23/2020-11/06/2020 Class# 30520 meets 10/23/2020-11/06/2020 Class# 30524 meets 10/23/2020-11/06/2020 Class# 30526 meets 10/23/2020-11/06/2020				
<b>COS 62A - 11.0 UNITS ADVANCED COSMETOLOGY I</b> Not Transferable Prerequisite: COS 61B or COS 70B with a grade of "C" or higher or "Pass".					<b>30501 11:00-12:15PM TTh</b> Class# 30501 meets 09/08/2020-09/24/2020 Gaucin, J				
22225	8:00-10:25AM 10:25- 4:20PM	MTWThF MTWThF	Motruk,N Motruk,N	REMOTE HS204	30528	9:00-11:50AM	Sat	Wang,L	REMOTE
The lab portion of this class will be a hybrid - partially on campus & partially online. The class will be divided into two groups. Each group will be on campus partially. You will be contacted by your instructor on which group you will be assigned to. Class# 22225 meets 08/17/2020-10/16/2020					Class# 30528 meets 09/12/2020-09/26/2020 Class# 30516 meets 10/23/2020-11/06/2020 Class# 30520 meets 10/23/2020-11/06/2020 Class# 30524 meets 10/23/2020-11/06/2020 Class# 30526 meets 10/23/2020-11/06/2020				
<b>COS 62B - 11.0 UNITS ADVANCED COSMETOLOGY II</b> Not Transferable Prerequisite: COS 62A with a grade of "C" or higher or "Pass".					<b>30516 9:00-11:50AM F</b> Class# 30516 meets 10/23/2020-11/06/2020 Walsh,M				
22227	8:00-10:30AM 10:30- 4:50PM	MTWThF MTWThF	Motruk,N Motruk,N	REMOTE HS204	30520	9:00-11:50AM	F	Hernandez,M	REMOTE
The lab portion of this class will be a hybrid - partially on campus & partially online. The class will be divided into two groups. Each group will be on campus partially. You will be contacted by your instructor on which group you will be assigned to. Class# 22227 meets 10/19/2020-12/18/2020					Class# 30520 meets 10/23/2020-11/06/2020 Class# 30524 meets 10/23/2020-11/06/2020 Class# 30526 meets 10/23/2020-11/06/2020				
<b>COS 99 - 2.0 UNITS DIRECTED STUDIES</b> Not Transferable					<b>30510 5:00-7:50PM Th</b> Class# 30510 meets 09/10/2020-09/24/2020 Gonzalez,A				
30004	12.0 HRS ARR (OL)		Motruk,N	ONLINE	30505	3:00- 4:15PM	MW	Ross,C	REMOTE
Class# 30004 meets 10/19/2020-12/18/2020					Class# 30505 meets 09/28/2020-10/14/2020 Class# 30502 meets 09/29/2020-10/15/2020 Class# 30529 meets 10/03/2020-10/17/2020				
					<b>30508 5:00- 7:50PM M</b> Class# 30508 meets 09/28/2020-10/12/2020 Quilizapa,C				
					<b>30511 5:00- 7:50PM Th</b> Class# 30511 meets 10/01/2020-10/15/2020 Alvarado,J				
					Class# 30530 meets 10/24/2020-11/07/2020 Class# 30530 meets 10/24/2020-11/07/2020				

If a class displays as **REMOTE** in the schedule, students will be expected to log into the class at a specified day/time (e.g., MW 8-9:15am). If the class displays as **ONLINE** in the schedule, students are permitted to log into the class whenever they are available to complete coursework by the established deadlines.

Students not in attendance or late for the first class meeting are subject to drop.



Class#	Time	Day	Instructor	Room	Class#	Time	Day	Instructor	Room
<b>30512</b>	<b>5:00- 7:50PM</b>	<b>Th</b>	Gonzalez, A	REMOTE	25579	12:30- 1:45PM	TTh	Hill,S	REMOTE
	Class# 30512 meets 10/22/2020-11/05/2020				25032	3.0 HRS ARR	(OL)	Bello,F	ONLINE
<b>30509</b>	<b>5:00- 7:50PM</b>	<b>M</b>	Quilizapa,C	REMOTE	26431	1:00- 2:15PM	TTh	Aslanyan,K	EOPS REMOTE
	Class# 30509 meets 10/19/2020-11/02/2020				26347	3.0 HRS ARR	(OL)	Herrera,M	ONLINE
30506	3:00- 4:15PM	MW	Ross,C	REMOTE	26348	11:00-12:15PM	MW	Aguilar,M	LINC REMOTE
	Class# 30506 meets 10/19/2020-11/04/2020				30043	3.0 HRS ARR	(OL)	Bello,F	ONLINE
30503	11:00-12:15PM	TTh	Gaucin, J	REMOTE	30044	3.0 HRS ARR	(OL)	Castro,R	ONLINE
	Class# 30503 meets 10/20/2020-11/05/2020				30308	8:00- 9:15AM	MW	Wang,L	REMOTE
30531	3.0 HRS ARR	(OL)	Gallardo,B	ONLINE	30310	3.0 HRS ARR	(OL)	Delacruz,G	ONLINE
	Class# 30531 meets 09/09/2020-09/29/2020				29585	3.6 HRS ARR	(OL)	Zier,J	ONLINE
30532	3.0 HRS ARR	(OL)	Gonzalez, A	ONLINE		Class# 29585 meets 09/08/2020-12/18/2020			
	Class# 30532 meets 09/28/2020-10/16/2020				29584	8:00- 9:35AM	MW	Lee,R	REMOTE
30533	3.0 HRS ARR	(OL)	Bello,F	ONLINE		Class# 29584 meets 09/09/2020-12/16/2020			
	Class# 30533 meets 10/19/2020-11/06/2020				20133	6.0 HRS ARR	(OL)	Gallardo,B	ONLINE
30313	1.5 HRS ARR	(OL)	Ukita,T	ONLINE		Class# 20133 meets 08/17/2020-10/16/2020			
	Class# 30313 meets 09/28/2020-11/06/2020				22306	6.0 HRS ARR	(OL)	Hoyle,S	ONLINE
<b>30312</b>	<b>5:00- 6:15PM</b>	<b>T</b>	Gaucin, J	REMOTE		Class# 22306 meets 08/17/2020-10/16/2020			
	Class# 30312 meets 08/18/2020-09/22/2020				30306	6.0 HRS ARR	(OL)	Gallardo,B	ONLINE
<b>30314</b>	<b>5:00- 6:15PM</b>	<b>W</b>	Alvardao, J	REMOTE		Class# 30306 meets 10/19/2020-12/18/2020			
	Class# 30314 meets 08/19/2020-09/23/2020				30307	6.0 HRS ARR	(OL)	Hoyle,S	ONLINE
<b>30315</b>	<b>5:00- 6:15PM</b>	<b>W</b>	Gaucin, J	REMOTE		Class# 30307 meets 10/19/2020-12/18/2020			
	Class# 30315 meets 09/30/2020-11/04/2020								
23687	1.5 HRS ARR	(OL)	Valenzuela,R	ONLINE					
	Class# 23687 meets 11/10/2020-12/15/2020								
27964	12:00-12:50PM	T	Cutkomp, J (Athletes)	REMOTE					
	Class# 27964 meets 08/18/2020-10/13/2020								
27965	1:00- 1:50PM	T	Mahoney, M (Athletes)	REMOTE					
	Class# 27965 meets 08/18/2020-10/13/2020								
<b>27966</b>	<b>5:00- 5:50PM</b>	<b>T</b>	Chew, H (Athletes)	REMOTE					
	Class# 27966 meets 08/18/2020-10/13/2020								
27967	1:00- 1:50PM	T	Fisher, C (Athletes)	REMOTE	30536	2.0 HRS ARR	(OL)	STAFF	ONLINE
	Class# 27967 meets 08/18/2020-10/13/2020					Class# 30536 meets 08/17/2020-10/16/2020			
27968	12:00-12:50PM	T	Chew, H (Athletes)	REMOTE	25517	2.0 HRS ARR	(OL)	Aiton,A	ONLINE
	Class# 27968 meets 08/18/2020-10/13/2020					Class# 25517 meets 10/19/2020-12/18/2020			
27969	1:00- 1:50PM	T	Cutkomp, J (Athletes)	REMOTE					
	Class# 27969 meets 08/18/2020-10/13/2020								
<b>27971</b>	<b>5:00- 5:50PM</b>	<b>T</b>	Fisher, C (Athletes)	REMOTE					
	Class# 27971 meets 08/18/2020-10/13/2020								
	<b>COUN 101C - 1.0 UNIT NAVIGATING THE TRANSFER PROCESS</b>								
	Transferable to CSU								
29419	2.0 HRS ARR	(OL)	Lundeen,B	ONLINE					
	Class# 29419 meets 08/17/2020-10/16/2020								
	<b>COUN 150 - 3.0 UNITS DYNAMICS OF LEADERSHIP</b>								
	Transferable to CSU								
	Recommendation: Satisfactory completion of the English Placement Process or ENGL 52 or equivalent with a grade of Pass or "C" or higher and participation in a college or community-based organization or club.								
29421	11:00-12:15PM	MW	Hurtado,H	REMOTE					
	<b>COUN 200 - 3.0 UNITS SUCCESS IN COLLEGE AND CAREER</b>								
	Transferable to UC, CSU								
	Recommendation: Completion of ENGL 20 or equivalent with a grade of "C" or higher or "Pass" or completion of the English Placement Process with eligibility for ENGL 52, ENGL 72, and ESL 152.								
	NOTE: a material fee of \$28.00 is required for COUN 200								
26201	9:30-10:45AM	TTh	Mahoney, M (Athletes)	REMOTE					
22518	9:30-10:45AM	TTh	Aguayo,R	REMOTE					
	This COUN 200 class is part of the Health Occupations House in the First Year Experience Program, which includes ENGL 100 (#27865), MATH 5 (#29045), MATH 112 (#20339), and SOC 101 (#20550). To learn more about FYE and to enroll in this house, please visit <a href="https://www.cerritos.edu/lcp/fye.htm">https://www.cerritos.edu/lcp/fye.htm</a> .								
30041	9:30-10:45AM	MW	Majano,N	REMOTE					
22519	12:30- 1:45PM	TTh	Romero,G (PUENTE)	REMOTE					
	This COUN 200 class is part of the Puente Learning Community, which includes ENGL 100S #30095. For additional information on PUENTE, please contact the program counselor/coordinator Gustavo Romero at <a href="mailto:gromero@cerritos.edu">gromero@cerritos.edu</a> .								
21233	4:00- 6:50PM	W	Quilizapa,C	REMOTE					
22047	1:00- 3:50PM	F	Carrillo,R	REMOTE					
25033	3.0 HRS ARR	(OL)	Herrera,V	ONLINE					
30497	12:30- 1:45PM	MW	Fisher,C (OL)	REMOTE					
	This COUN 200 class is part of the Arts, Humanities, & Communication House in the First Year Experience Program, which includes ENGL 100 (#26510), MATH 5 (#29060), and MATH 112 (#24343). To learn more about FYE and to enroll in this house, please visit <a href="https://www.cerritos.edu/lcp/fye.htm">https://www.cerritos.edu/lcp/fye.htm</a> .								

## CULINARY ARTS

### CA 55 - 1.0 UNIT FUNDAMENTALS OF RESPONSIBLE ALCOHOL SERVICE

Not Transferable

30536	2.0 HRS ARR	(OL)	STAFF	ONLINE
	Class# 30536 meets 08/17/2020-10/16/2020			
25517	2.0 HRS ARR	(OL)	Aiton,A	ONLINE
	Class# 25517 meets 10/19/2020-12/18/2020			

### CA 101 - 1.0 UNIT INTRODUCTION TO FOOD SERVICE, SAFETY, AND SANITATION

Transferable to CSU

30537	4:00- 4:50PM	T	STAFF	REMOTE
20890	2:00- 3:50PM	T	Yu,J	REMOTE
	Class# 20890 meets 08/18/2020-10/13/2020			
20900	2:00- 3:50PM	T	Yu,J	REMOTE
	Class# 20900 meets 10/20/2020-12/15/2020			

### CA 120 - 3.0 UNITS INTRODUCTION TO THE HOSPITALITY INDUSTRY

Transferable to CSU

24705	3.0 HRS ARR	(OL)	Lew,E	ONLINE
-------	-------------	------	-------	--------

### CA 230 - 3.0 UNITS PROFESSIONAL HEALTHY COOKING

Transferable to CSU

24706	2:00- 4:50PM	T	Pierini,M	REMOTE
-------	--------------	---	-----------	--------

### CA 240 - 3.0 UNITS HUMAN RELATIONS IN HOSPITALITY

Transferable to CSU

30538	3.0 HRS ARR	(OL)	STAFF	ONLINE
-------	-------------	------	-------	--------

### CA 250 - 7.0 UNITS PROFESSIONAL COOKING I

Transferable to CSU

24187	1:00- 4:50PM	F	Lopez,J	CB102
-------	--------------	---	---------	-------

Corequisite: CA 101 or prior completion or equivalent with a grade of "C" or higher or "Pass."  
 Recommendation: Completion of ENGL 52 or ENGL 72 or ESL 152 or equivalent with a grade of "C" or higher or "Pass" or completion of the assessment/placement process with eligibility for ENGL 100 or ENGL 100S.  
 NOTE: a material fee of \$50.00 is required for CA 250 24187 ONLINE. NOTE: 24187 is the enrollment section so #24188 should be suppressed.

### CA 260 - 3.0 UNITS FOODS PURCHASE AND CONTROL

Transferable to CSU

24193	3.0 HRS ARR	(OL)	Lew,E	ONLINE
-------	-------------	------	-------	--------

If a class displays as **REMOTE** in the schedule, students will be expected to log into the class at a specified day/time (e.g., MW 8-9:15am). If the class displays as **ONLINE** in the schedule, students are permitted to log into the class whenever they are available to complete coursework by the established deadlines.

Students not in attendance or late for the first class meeting are subject to drop.

Class#	Time	Day	Instructor	Room	Class#	Time	Day	Instructor	Room
<b>DANCE</b>					26229	2:00- 2:30PM	MW	Berney,D	REMOTE
						2:30- 3:50PM	MW	Berney,D	REMOTE
					22361	10:00-11:10AM	Sat	Cole,P	REMOTE
						11:10- 2:35PM	Sat	Cole,P	REMOTE
					Class# 22361 meets 08/22/2020-12/12/2020				
<b>DANC 50 - 1.0 UNIT INDIVIDUALIZED DANCE DEVELOPMENT</b>					<b>DANC 106B - 2.0 UNITS INTERMEDIATE BALLET</b>				
Not Transferable					Transferable to UC, CSU				
27702	2:00- 5:50PM	F	Gregory,C	REMOTE	27988	9:00- 9:30AM	TTh	Ibarguen Allpas,V	REMOTE
Class# 27702 meets 08/24/2020-12/18/2020						9:30-10:50AM	TTh	Ibarguen Allpas,V	REMOTE
<b>DANC 100 - 3.0 UNITS DANCE APPRECIATION</b>					26233	2:00- 2:30PM	MW	Berney,D	REMOTE
Transferable to UC, CSU						2:30- 3:50PM	MW	Berney,D	REMOTE
24020	9:30-10:45AM	MW	Roman-Rodriguez,D	REMOTE	26235	10:00-11:10AM	Sat	Cole,P	REMOTE
21800	3.0 HRS ARR	(OL)	Berney,D	ONLINE		11:10- 2:35PM	Sat	Cole,P	REMOTE
24484	9:00-11:50AM	F	Hendrix,J	REMOTE	Class# 26235 meets 08/22/2020-12/12/2020				
27084	3.6 HRS ARR	(OL)	Ibarguen Allpas,V	ONLINE	<b>DANC 106C - 2.0 UNITS ADVANCED BALLET</b>				
Class# 27084 meets 09/08/2020-12/18/2020					Transferable to UC, CSU				
29898	9.0 HRS ARR	(OL)	STAFF	ONLINE	30227	9:00- 9:30AM	TTh	Ibarguen Allpas,V	REMOTE
Class# 29898 meets 10/19/2020-11/25/2020						9:30-10:50AM	TTh	Ibarguen Allpas,V	REMOTE
29825	9.0 HRS ARR	(OL)	STAFF	ONLINE	30229	2:00- 2:30PM	MW	Berney,D	REMOTE
Class# 29825 meets 09/28/2020-11/05/2020						2:30- 3:50PM	MW	Berney,D	REMOTE
22679	6.0 HRS ARR	(OL)	Hathaway,R	ONLINE	30231	10:00-11:10AM	Sat	Cole,P	REMOTE
Targeted for Future Teachers but Open to all Students						11:10- 2:35PM	Sat	Cole,P	REMOTE
Class# 22679 meets 08/17/2020-10/16/2020					Class# 30231 meets 08/22/2020-12/12/2020				
27555	6.0 HRS ARR	(OL)	Gregory,C	ONLINE	<b>DANC 107 - 2.0 UNITS BALLET VARIATIONS</b>				
Class# 27555 meets 08/17/2020-10/16/2020					Transferable to UC, CSU				
28158	6.0 HRS ARR	(OL)	Gregory,C	ONLINE	27990	9:00- 9:30AM	TTh	Ibarguen Allpas,V	REMOTE
Targeted for Future Teachers but Open to all Students						9:30-10:50AM	TTh	Ibarguen Allpas,V	REMOTE
Class# 28158 meets 08/17/2020-10/16/2020					27992	2:00- 2:30PM	MW	Berney,D	REMOTE
28735	6.0 HRS ARR	(OL)	Hathaway,R	ONLINE		2:30- 3:50PM	MW	Berney,D	REMOTE
Targeted for Future Teachers but Open to all Students					26237	10:00-11:10AM	Sat	Cole,P	REMOTE
Class# 28735 meets 08/17/2020-10/16/2020						11:10- 2:35PM	Sat	Cole,P	REMOTE
22083	6.0 HRS ARR	(OL)	Hathaway,R	ONLINE	Class# 26237 meets 08/22/2020-12/12/2020				
Targeted for Future Teachers but Open to all Students					<b>DANC 108A - 2.0 UNITS DANCE, MODERN, BEGINNING</b>				
Class# 22083 meets 10/19/2020-12/18/2020					Transferable to UC, CSU				
26742	6.0 HRS ARR	(OL)	Gregory,C	ONLINE	22203	12:30-1:00PM	TTh	Wicks,K	REMOTE
Targeted for Future Teachers but Open to all Students						1:00-2:20PM	TTh	Wicks,K	REMOTE
Class# 26742 meets 10/19/2020-12/18/2020					28159	12:00-12:30PM	MW	Roman-Rodriguez,D	REMOTE
28682	6.0 HRS ARR	(OL)	Gregory,C	ONLINE		12:30- 1:50PM	MW	Roman-Rodriguez,D	REMOTE
Class# 28682 meets 10/19/2020-12/18/2020					<b>DANC 108B - 2.0 UNITS DANCE, MODERN, INTERMEDIATE</b>				
28924	6.0 HRS ARR	(OL)	Hathaway,R	ONLINE	Transferable to UC, CSU				
Targeted for Future Teachers but Open to all Students					21808	12:30- 1:00PM	TTh	Wicks,K	REMOTE
Class# 28924 meets 10/19/2020-12/18/2020						1:00- 2:20PM	TTh	Wicks,K	REMOTE
29824	6.0 HRS ARR	(OL)	Gregory,C	ONLINE	28161	12:00-12:30PM	MW	Roman-Rodriguez,D	REMOTE
Class# 29824 meets 10/19/2020-12/18/2020						12:30- 1:50PM	MW	Roman-Rodriguez,D	REMOTE
<b>DANC 101 - 3.0 UNITS HISTORY OF DANCE</b>					<b>DANC 108C - 2.0 UNITS DANCE, MODERN ADVANCED</b>				
Transferable to UC, CSU					Transferable to UC, CSU				
24485	9:30-10:45AM	TTh	Hendrix,J	REMOTE	30233	12:30- 1:00PM	TTh	Wicks,K	REMOTE
27703	3.0 HRS ARR	(OL)	Berney,D	ONLINE		1:00- 2:20PM	TTh	Wicks,K	REMOTE
30220	3.6 HRS ARR	(OL)	Wicks,K	ONLINE	30235	12:00-12:30PM	MW	Roman-Rodriguez,D	REMOTE
Class# 30220 meets 09/08/2020-12/18/2020						12:30- 1:50PM	MW	Roman-Rodriguez,D	REMOTE
<b>DANC 102 - 2.0 UNITS INTRODUCTION TO ADAPTIVE DANCE</b>					<b>DANC 109 - 2.0 UNITS INTRODUCTION TO DANCE CULTURES OF THE WORLD</b>				
Transferable to UC, CSU					Transferable to UC, CSU				
29611	9:00- 9:30AM	TTh	Horner,B	REMOTE	29284	3:00- 4:30PM	TTh	Robertson,J	REMOTE
	9:30-10:50AM	TTh	Horner,B	REMOTE	30409	2:30- 3:00PM	TTh	Robertson,J	REMOTE
<b>DANC 103 - 1.0 UNIT DANCE CONDITIONING AND ALIGNMENT</b>					<b>DANC 110 - 2.0 UNITS COMMERCIAL DANCE FOUNDATIONS</b>				
Transferable to UC, CSU					Transferable to UC, CSU				
30221	11:00-11:15AM	MW	Roman-Rodriguez,D	REMOTE	21810	10:00-11:00AM	F	Cabag,V	REMOTE
	11:15-11:50AM	MW	Roman-Rodriguez,D	REMOTE		11:00- 1:50PM	F	Cabag,V	REMOTE
30223	11:00-11:15AM	TTh	Horner,B	REMOTE	22084	12:30- 1:00PM	TTh	Robertson,J	REMOTE
	11:15-11:50AM	TTh	Horner,B	REMOTE		1:00- 2:20PM	TTh	Robertson,J	REMOTE
<b>DANC 104 - 1.0 UNIT CARDIO BARRE CONDITIONING</b>					<b>DANC 112 - 2.0 UNITS CONTEMPORARY DANCE</b>				
Transferable to UC, CSU					Transferable to UC, CSU				
30225	5:30- 5:45PM	TTh	Wicks,K	REMOTE	23695	4:00- 4:30PM	MW	Jones,M	REMOTE
	5:45- 6:20PM	TTh	Wicks,K	REMOTE		4:30- 5:50PM	MW	Jones,M	REMOTE
<b>DANC 105 - 3.0 UNITS INTRODUCTION TO DANCE MOVEMENT</b>					30237	2:30- 3:00PM	TTh	Robertson,J	REMOTE
Transferable to UC, CSU						3:00- 4:30PM	TTh	Robertson,J	REMOTE
21802	2.0 HRS ARR	(OL)	Horner,B	ONLINE					
	9:00-10:50AM	TTh	Horner,B	REMOTE					
+ 1 hour of arranged lecture									
<b>DANC 106A - 2.0 UNITS BEGINNING BALLET</b>									
Transferable to UC, CSU									
27986	9:00- 9:30AM	TTh	Ibarguen Allpas,V	REMOTE					
	9:30-10:50AM	TTh	Ibarguen Allpas,V	REMOTE					

If a class displays as **REMOTE** in the schedule, students will be expected to log into the class at a specified day/time (e.g., MW 8-9:15am). If the class displays as **ONLINE** in the schedule, students are permitted to log into the class whenever they are available to complete coursework by the established deadlines.

Students not in attendance or late for the first class meeting are subject to drop.

Class#	Time	Day	Instructor	Room	Class#	Time	Day	Instructor	Room
<b>DANC 115 - 2.0 UNITS LITURGICAL DANCE</b>					<b>DANC 140 - 2.0 UNITS BEGINNING JAZZ DANCE</b>				
Transferable to UC, CSU					Transferable to UC, CSU				
30239	4:00- 4:30PM	MW	Jones,M	REMOTE	21822	10:00-10:30AM	MW	Cabag,V	REMOTE
	4:30- 5:50PM	MW	Jones,M	REMOTE		10:30-11:50AM	MW	Cabag,V	REMOTE
<b>DANC 120 - 2.0 UNITS PARTNERING FOR DANCE</b>					<b>DANC 141 - 2.0 UNITS INTERMEDIATE JAZZ DANCE</b>				
Transferable to UC, CSU					Transferable to UC, CSU				
29285	4:30- 5:00PM	TTh	Rosa,S	REMOTE	Prerequisite: TH 140 or DANC 140 or equivalent with a grade of Pass or "C" or higher.				
	5:00- 6:20PM	TTh	Rosa,S	REMOTE	21823	10:00-10:30AM	MW	Cabag,V	REMOTE
<b>DANC 121 - 2.0 UNITS LATIN SOCIAL DANCE</b>					10:30-11:50AM MW Cabag,V REMOTE				
Transferable to UC, CSU					<b>DANC 142 - 2.0 UNITS BEGINNING TAP DANCE</b>				
27704	6:00- 6:30PM	MW	Cole,P	REMOTE	Transferable to UC, CSU				
	6:30- 7:50PM	MW	Cole,P	REMOTE	29291	12:00-12:30PM	MW	Cabag,V	REMOTE
29287	4:30- 5:00PM	TTh	Rosa,S	REMOTE		12:30- 1:50PM	MW	Cabag,V	REMOTE
	5:00- 6:20PM	TTh	Rosa,S	REMOTE	<b>DANC 143 - 2.0 UNITS INTERMEDIATE TAP DANCE</b>				
<b>DANC 123 - 2.0 UNITS AFRICAN DANCE</b>					Transferable to UC, CSU				
Transferable to UC, CSU					Prerequisite: TH 142 or DANC 142 or equivalent with a grade of Pass or "C" or higher.				
30241	2:00- 2:30PM	MW	Jones,M	REMOTE	29293	12:00-12:30PM	MW	Cabag,V	REMOTE
	2:30- 3:50PM	MW	Jones,M	REMOTE		12:30- 1:50PM	MW	Cabag,V	REMOTE
<b>DANC 124 - 2.0 UNITS HIP HOP DANCE I</b>					<b>DANC 144 - 2.0 UNITS DANCE FOR MUSICAL THEATRE</b>				
Transferable to UC, CSU					Transferable to UC, CSU				
22363	12:30- 1:00PM	MW	Robertson,J	REMOTE	30410	10:00-10:30AM	MW	Cabag,V	REMOTE
	1:00- 2:20PM	MW	Robertson,J	REMOTE		10:30-11:50AM	MW	Cabag,V	REMOTE
24486	10:00-11:00AM	F	Cabag,V	REMOTE	<b>DANC 125 - 2.0 UNITS INTRODUCTION TO BALLROOM DANCE</b>				
	11:00- 1:50PM	F	Cabag,V	REMOTE	Transferable to UC, CSU				
<b>DANC 125 - 2.0 UNITS INTRODUCTION TO BALLROOM DANCE</b>					<b>DANC 126 - 2.0 UNITS HIP HOP DANCE II</b>				
Transferable to UC, CSU					Transferable to UC, CSU				
29289	6:00- 6:30PM	MW	Cole,P	REMOTE	27085	12:30- 1:00PM	TTh	Robertson,J	REMOTE
	6:30- 7:50PM	MW	Cole,P	REMOTE		1:00- 2:20PM	TTh	Robertson,J	REMOTE
<b>DANC 126 - 2.0 UNITS HIP HOP DANCE II</b>					30245				
Transferable to UC, CSU					10:00-11:00AM F Cabag,V REMOTE				
27085	12:30- 1:00PM	TTh	Robertson,J	REMOTE		11:00- 1:50PM	F	Cabag,V	REMOTE
	1:00- 2:20PM	TTh	Robertson,J	REMOTE	<b>DANC 128 - 2.0 UNITS LATIN DANCE PERFORMANCE</b>				
30245	10:00-11:00AM	F	Cabag,V	REMOTE	Transferable to UC, CSU				
	11:00- 1:50PM	F	Cabag,V	REMOTE	30247	4:30-5:30PM	TTh	Rosa,S	REMOTE
<b>DANC 128 - 2.0 UNITS LATIN DANCE PERFORMANCE</b>					5:30- 6:20PM Th Rosa,S REMOTE				
Transferable to UC, CSU					30249				
30247	4:30-5:30PM	TTh	Rosa,S	REMOTE	6:00- 6:30PM MW Cole,P REMOTE				
	5:30- 6:20PM	Th	Rosa,S	REMOTE		6:30- 7:50PM	MW	Cole,P	REMOTE
30249	6:00- 6:30PM	MW	Cole,P	REMOTE	<b>DANC 129 - 2.0 UNITS HEELS DANCE CLASS</b>				
	6:30- 7:50PM	MW	Cole,P	REMOTE	Transferable to UC, CSU				
<b>DANC 129 - 2.0 UNITS HEELS DANCE CLASS</b>					30251				
Transferable to UC, CSU					7:00- 9:50PM F Rosa,S REMOTE				
30251	7:00- 9:50PM	F	Rosa,S	REMOTE		7:00- 9:50PM	F	Rosa,S	REMOTE
<b>DANC 130A - 2.0 UNITS BEGINNING CHOREOGRAPHY</b>					<b>DANC 130B - 2.0 UNITS INTERMEDIATE CHOREOGRAPHY</b>				
Transferable to UC, CSU					Transferable to UC, CSU				
30253	10:00-10:30AM	F	Wicks,K	REMOTE	30255	10:00-10:30AM	F	Wicks,K	REMOTE
	10:30-1:50PM	F	Wicks,K	REMOTE		10:30- 1:50PM	F	Wicks,K	REMOTE
<b>DANC 132 - 3.0 UNITS DANCE AND TECHNOLOGY</b>					<b>DANC 133 - 3.0 UNITS DANCE AND TECHNOLOGY</b>				
Transferable to UC, CSU					Transferable to UC, CSU				
Recommendation: Basic computer skills and dance knowledge recommended.					Recommendation: Basic computer skills and dance knowledge recommended.				
30257	10:00-12:50PM	F	Wicks,K	REMOTE	<b>DANC 134 - 2.0 UNITS DANCE PERFORMANCE</b>				
<b>DANC 134 - 2.0 UNITS DANCE PERFORMANCE</b>					Transferable to UC, CSU				
28164	6.4 HRS ARR (OL)		Hathaway,R	ONLINE	Class# 28164 meets 08/24/2020-12/18/2020				
<b>DANC 136 - 2.0 UNITS DANCE REPERTORY</b>					<b>DANC 135 - 2.0 UNITS DANCE REPERTORY</b>				
Transferable to UC, CSU					Transferable to UC, CSU				
27290	6.4 HRS ARR		Gregory,C	REMOTE	27290	2:00- 5:50PM	F	Gregory,C	REMOTE
	2:00- 5:50PM	F	Gregory,C	REMOTE	<b>DANC 140 - 2.0 UNITS BEGINNING JAZZ DANCE</b>				

## DENTAL ASSISTING

Applications for Fall 2021 admission to the Dental Assisting Program are due in the Applications for Fall 2021 admission to the Dental Hygiene Program are due in the Health Occupations Division Office no later than April 1, 2020. Students must be accepted into the Dental Hygiene Program prior to enrolling in any class. For more information call (562) 860-2451, ext. 2550.

Clearance of a criminal background check and/or drugs of abuse

### DA 51 - 4.0 UNITS APPLIED DENTAL SCIENCE I

Not Transferable

NOTE: a material fee of \$27.00 is required for DA 51

20149 8:00-10:50AM M Cosio,L REMOTE  
PLEASE ENROLL IN LAB SECTION OF YOUR CHOICE. THE LECTURE SECTION #20149 WILL BE AUTOMATICALLY ADDED.

20150 8:00-10:50AM W Saucedo,M LAB A HS304  
30539 11:00-1:50PM W Cosio,L LAB B HS304

### DA 52 - 2.0 UNITS DENTAL RADIOGRAPHY I

Not Transferable

NOTE: a material fee of \$67.00 is required for DA 52

20151 11:00-11:50AM M Hurtado,T REMOTE  
PLEASE ENROLL IN LAB SECTION OF YOUR CHOICE. THE LECTURE SECTION #20151 WILL BE AUTOMATICALLY ADDED.

20153 8:00-10:50AM Th Cosio,L LAB A HS308  
20154 12:30- 3:20PM Th Cosio,L LAB B HS308

### DA 53 - 3.0 UNITS INTRODUCTION TO CHAIRSIDE ASSISTING

Not Transferable

Corequisite: DA 54.

NOTE: a material fee of \$30.00 is required for DA 53

20155 + 2.0 HRS ARR (OL) Contreras,A ONLINE  
PLEASE ENROLL IN LAB SECTION AS ASSIGNED. THE LECTURE SECTION #20155 WILL BE AUTOMATICALLY ADDED.

20157 12:30- 3:20PM T Contreras,A LAB A HS307  
20156 8:00-10:50AM T Contreras,A LAB B HS307

### DA 54 - 4.0 UNITS INTRODUCTION TO OPERATORY PROCEDURES

Not Transferable

Corequisite: DA 53.

NOTE: a material fee of \$45.00 is required for DA 54

20159 + 2.0 HRS ARR (OL) Contreras,A ONLINE  
20161 12:30- 3:20PM ThF Contreras,A LAB A HS307  
20160 8:00-10:50AM ThF Contreras,A LAB B HS307

If a class displays as **REMOTE** in the schedule, students will be expected to log into the class at a specified day/time (e.g., MW 8-9:15am). If the class displays as **ONLINE** in the schedule, students are permitted to log into the class whenever they are available to complete coursework by the established deadlines.

Students not in attendance or late for the first class meeting are subject to drop.

Class#	Time	Day	Instructor	Room	Class#	Time	Day	Instructor	Room
<b>DA 75 - 5.0 UNITS CLINICAL II COOPERATIVE OFFICE TRAINING</b> Not Transferable Prerequisite: DA 65 or equivalent with a grade of Pass or "C" or higher. NOTE: a material fee of \$11.00 is required for DA 75									
30540	2.2 HRS ARR (OL)		STAFF	ONLINE					
	+21.3 HRS ARR (OL)		STAFF	ONLINE					
Class# 30540 meets 10/19/2020-12/18/2020									
<b>DENTAL HYGIENE</b>									
<b>DH 110 - 2.0 UNITS PREVENTIVE DENTISTRY I</b> Transferable to CSU									
20162	8:00- 9:50AM	Th	Shore,M	REMOTE					
<b>DH 111 - 2.0 UNITS INFECTION CONTROL AND DENTAL OFFICE EMERGENCIES</b> Transferable to CSU Corequisite: DH 115C.									
20163	3:00- 4:50PM	Th	STAFF	REMOTE					
<b>DH 112 - 2.0 UNITS DENTAL HYGIENE RADIOGRAPHY</b> Transferable to CSU NOTE: a material fee of \$75.00 is required for DH 112									
20164	7:00- 8:50PM	T	Krayer,A	REMOTE					
PLEASE ENROLL IN LAB SECTION OF YOUR CHOICE. THE LECTURE SECTION #20164 WILL BE AUTOMATICALLY ADDED.									
20165	9:00-11:50AM	W	Shore,M	LAB A	HS308				
20166	1:00- 3:50PM	W	Carroll,D	LAB B	HS308				
<b>DH 114 - 2.0 UNITS DENTAL HYGIENE CLINICAL SCIENCES I</b> Transferable to CSU Corequisite: DH 115C.									
20167	1:00-2:50PM	Th	Loera,D	REMOTE					
<b>DH 115C - 2.0 UNITS PRE-CLINICAL DENTAL HYGIENE I</b> Transferable to CSU Corequisite: DH 114. NOTE: a material fee of \$85.00 is required for DH 115C									
20168	8:30-11:20AM	M	Loera,D	HS303					
	1:00- 3:50PM	F	Grammatica,A	LAB A	HS303				
20169	8:30-11:20AM	M	Krayer,A	HS303					
	1:00- 3:50PM	F	Loera,D	LAB B	HS303				
20170	8:30-11:20AM	F	Loera,D	HS303					
	1:00- 3:50PM	M	Loera,D	LAB C	HS303				
20171	8:30-11:20AM	F	Grammatica,A	HS303					
	1:00- 3:50PM	M	Krayer,A	LAB D	HS303				
<b>DH 116 - 2.0 UNITS HEAD AND NECK ANATOMY</b> Transferable to CSU Corequisite: DH 119.									
20172	1:00- 2:50PM	T	Loera,D	REMOTE					
PLEASE ENROLL IN LAB SECTION OF YOUR CHOICE. THE LECTURE SECTION #20172 WILL BE AUTOMATICALLY ADDED.									
21000	4:00- 4:50PM	T	Loera,D	LAB A	HS103				
30542	5:00-5:50PM	T	Loera,D	LAB B	HS103				
<b>DH 119 - 2.0 UNITS DENTAL EMBRYOLOGY, HISTOLOGY, AND ANATOMY</b> Transferable to CSU Corequisite: DH 115C and DH 116.									
20173	6:30-8:20PM	M	Carroll,D	REMOTE					
PLEASE ENROLL IN LAB SECTION OF YOUR CHOICE. THE LECTURE SECTION #20173 WILL BE AUTOMATICALLY ADDED.									
21001	10:00-10:50AM	T	Carroll,D	HS304					
30543	9:00- 9:50AM	T	Carroll,D	HS304					
<b>DH 232L - 1.0 UNIT DENTAL MATERIALS LABORATORY</b> Transferable to CSU Corequisite: DH 235C. NOTE: a material fee of \$130.00 is required for DH 232L									
20174	1:00- 3:50PM	Th	Rozak,T	LAB A	HS303				
30549	4:00- 6:50PM	Th	Shore,M	LAB B	HS303				
30550	3:00- 5:50PM	T	Shore,M	LAB C	HS303				
<b>DH 234 - 2.0 UNITS DENTAL CARE FOR THE SPECIAL PATIENT</b> Transferable to CSU Prerequisite: DH 125C and DH 127 or equivalent with grades of Pass or "C" or higher. Corequisite: DH 235C.									
20175	11:00-12:50PM	T	Brabender,M	HS304					
<b>DH 235 - 2.0 UNITS DENTAL HYGIENE CLINICAL SCIENCES III</b> Transferable to CSU Prerequisite: DH 125C or equivalent with a grade of Pass or "C" or higher. Corequisite: DH 235C.									
20176	8:00- 8:50AM	W	Loera,D	REMOTE					
	5:00- 5:50PM	W	Carroll,D	REMOTE					
PLEASE ENROLL IN LAB SECTION OF YOUR CHOICE. THE LECTURE SECTION #20176 WILL BE AUTOMATICALLY ADDED.									
21661	10:00-10:50AM	W	Loera,D	LAB A	HS303				
30551	11:00-11:50AM	W	Loera,D	LAB B	HS303				
30552	12:00-12:50PM	W	Loera,D	LAB C	HS303				
<b>DH 238 - 1.0 UNIT COMMUNITY OUTREACH I</b> Transferable to CSU Prerequisite: DH 110 or equivalent with a grade of Pass or "C" or higher.									
21662	8:00- 9:00AM	Th	Brabender,M	REMOTE					
	10:00-10:50AM	Th	Brabender,M	REMOTE					
21664	11:30-12:30PM	Th	Brabender,M	REMOTE					
	12:30-1:20PM	Th	Brabender,M	REMOTE					
<b>DH 239 - 2.0 UNITS INTRODUCTION TO DENTAL BIOSTATISTICS AND RESEARCH</b> Transferable to CSU									
20181	9:00-10:50AM	T	Shore,M	REMOTE					
<b>EARTH SCIENCE</b>									
<b>ESCI 104 - 3.0 UNITS OCEANOGRAPHY</b> Transferable to UC, CSU Recommendation: ENGL 52 or ENGL 72 or ESL 152 or equivalent with a grade of "C" or higher or "Pass" or completion of the English assessment/placement process with a score eligible for ENGL 100 or ENGL 100S, and MATH 40 or equivalent with a grade of "C" or higher or "Pass" or completion of the Math assessment/placement process with a score eligible for MATH 60.									
21885	3.0 HRS ARR (OL)		DeKraker,D	ONLINE					
20697	3.0 HRS ARR (OL)		DeKraker,D	ONLINE					
Note: Orientation: All Class information will be available online via Canvas. Email address: ddekraker@cerritos.edu									
27394	3.0 HRS ARR (OL)		DeKraker,D	ONLINE					
27955	3.0 HRS ARR (OL)		DeKraker,D	ONLINE					
Note: Orientation: All Class information will be available online via Canvas. Email address: ddekraker@cerritos.edu									
<b>ESCI 104L - 1.0 UNIT OCEANOGRAPHY LABORATORY</b> Transferable to UC, CSU Prerequisite: ESCI 104 or equivalent with a grade of "C" or higher or "Pass" or concurrent enrollment. Recommendation: ENGL 52 or ENGL 72 or ESL 152 or equivalent with a grade of "C" or higher or "Pass" or completion of the English assessment/placement process with a score eligible for ENGL 100 or ENGL 100S, and MATH 40 or equivalent with a grade of "C" or higher or "Pass" or completion of the Math assessment/placement process with a score eligible for MATH 60.									
21886	3.0 HRS ARR (OL)		DeKraker,D	ONLINE					
<b>ESCI 106 - 3.0 UNITS WEATHER AND CLIMATE</b> Transferable to UC, CSU Recommendation: ENGL 52 or ENGL 72 or ESL 152 or equivalent with a grade of "C" or higher or "Pass" or completion of the English assessment/placement process with a score eligible for ENGL 100 or ENGL 100S, and MATH 40 or equivalent with a grade of "C" or higher or "Pass" or completion of the Math assessment/placement process with a score eligible for MATH 60.									
29363	6.0 HRS ARR (OL)		Vines,A	ONLINE					
Note: Orientation: All course information will be provided on Canvas. Please contact the instructor avines@cerritos.edu for more information. Class# 29363 meets 08/17/2020-10/16/2020									

If a class displays as **REMOTE** in the schedule, students will be expected to log into the class at a specified day/time (e.g., MW 8-9:15am). If the class displays as **ONLINE** in the schedule, students are permitted to log into the class whenever they are available to complete coursework by the established deadlines.

Students not in attendance or late for the first class meeting are subject to drop.

Class#	Time	Day	Instructor	Room	Class#	Time	Day	Instructor	Room
<b>ESCI 110 - 4.0 UNITS INTRODUCTION TO EARTH SCIENCE</b>					<b>ECON 201M - 3.0 UNITS PRINCIPLES OF MACROECONOMICS</b>				
Transferable to UC, CSU					Transferable to UC, CSU				
Recommendation: ENGL 52 or ENGL 72 or ESL 152 or equivalent with a grade of "C" or higher or "Pass" or completion of the English assessment/placement process with a score eligible for ENGL 100 or ENGL 100S, and MATH 40 or equivalent with a grade of "C" or higher or "Pass" or completion of the Math assessment/placement process with a score eligible for MATH 60.					Prerequisite: MATH 60 or equivalent with a grade of "C" or higher or "Pass" or completion of the assessment/placement process with eligibility for MATH 80 or MATH 80A or higher.				
Recommendation: ENGL 100 or ENGL 100S or equivalent with a grade of "C" or higher or "Pass".					Recommendation: ENGL 100 or ENGL 100S or equivalent with a grade of "C" or higher or "Pass".				
20223	3.0 HRS ARR	(OL)	Okbamichael,M	ONLINE	<b>24438</b>	<b>6:00-9:00PM</b>	<b>Th</b>	Tahernia,F	REMOTE
	+ 3.0 HRS ARR	(OL)	Okbamichael,M	ONLINE		B9:00-9:50PM	Th	Tahernia,F	REMOTE
23824	3.0 HRS ARR	(OL)	Lacy,T	ONLINE	24442	3.0 HRS ARR	(OL)	Merino-Hernandez,H	ONLINE
	Targeted for Future Teachers but Open to all Students					+ 1.0 HRS ARR	(OL)	Merino-Hernandez,H	ONLINE
	+ 3.0 HRS ARR	(OL)	Lacy,T	ONLINE	24444	3.0 HRS ARR	(OL)	Vayo II,L	ONLINE
20224	3.0 HRS ARR	(OL)	DeKraker,D	ONLINE		Note: For class information and orientation go to Canvas.			
	Targeted for Future Teachers but Open to all Students					+ 1.0 HRS ARR	(OL)	Vayo II,L	ONLINE
	+ 3.0 HRS ARR	(OL)	DeKraker,D	ONLINE	26020	3.0 HRS ARR	(OL)	Chi,W	ONLINE
21267	3.0 HRS ARR	(OL)	Sedki,Z	ONLINE		+ 1.0 HRS ARR	(OL)	Chi,W	ONLINE
	+ 3.0 HRS ARR	(OL)	Sedki,Z	ONLINE	27258	3.0 HRS ARR	(OL)	Keenan,D	ONLINE
27661	3.0 HRS ARR	(OL)	Leeper III,R	ONLINE		Note: For class information and orientation go to Canvas.			
	+ 3.0 HRS ARR	(OL)	Leeper III,R	ONLINE		+ 1.0 HRS ARR	(OL)	Keenan,D	ONLINE
<b>ECONOMICS</b>					27732	3.0 HRS ARR	(OL)	Yilan,L	ONLINE
<b>ECON 101 - 3.0 UNITS ECONOMIC ISSUES AND POLICY</b>						Note: For class information and orientation go to Canvas.			
Transferable to UC, CSU					29532	3.0 HRS ARR	(OL)	Yilan,L	ONLINE
22882	3.0 HRS ARR	(OL)	Smith,S	ONLINE		+ 1.0 HRS ARR	(OL)	Chi,W	ONLINE
	Note: For class information and orientation go to Canvas.					+ 1.0 HRS ARR	(OL)	Chi,W	ONLINE
26791	9:00-10:35AM	MW	Namala,S	REMOTE	24440	8:30-9:50AM	TTh	Namala,S (Honors Section)	REMOTE
	Class# 26791 meets 08/17/2020-11/25/2020					9:50-10:40AM	TTh	Namala,S (Honors Section)	REMOTE
<b>25989</b>	<b>7:00-10:00PM</b>	<b>T</b>	Yilan,L	REMOTE		Class# 24440 meets 08/18/2020-11/19/2020			
	Class# 25989 meets 09/08/2020-12/15/2020				27013	11:00-2:00PM	MW	Namala,S	REMOTE
25515	9:00-12:30PM	F	Bahhour,F	REMOTE		2:00-2:50PM	MW	Namala,S	REMOTE
	Class# 25515 meets 09/11/2020-12/18/2020					Class# 27013 meets 08/17/2020-10/14/2020			
<b>ECON 102 - 3.0 UNITS WOMEN IN THE GLOBAL ECONOMY</b>					<b>ECON 202 - 3.0 UNITS PRINCIPLES OF MICROECONOMICS</b>				
Transferable to UC, CSU					Transferable to UC, CSU (CAN ECON 4)				
Recommendation: Completion of English assessment/placement process with a score eligible for ENGL 100 or ENGL 100S, or ENGL 52, or equivalent with a grade of "C" or higher or "Pass".					Prerequisite: MATH 40 or equivalent with a grade of "C" or higher or "Pass" or completion of the Math Placement Process with a score eligible for MATH 60.				
Recommendation: ENGL 100 or ENGL 100S or equivalent with a grade of "C" or higher or "Pass".					Recommendation: ENGL 100 or ENGL 100S or equivalent with a grade of "C" or higher or "Pass".				
29118	3.6 HRS ARR	(OL)	De Los Rios,K	ONLINE	23776	3.0 HRS ARR	(OL)	Keenan,D	ONLINE
	Class# 29118 meets 09/08/2020-12/18/2020					Note: For class information and orientation go to Canvas.			
<b>ECON 201 - 3.0 UNITS PRINCIPLES OF MACROECONOMICS</b>						+ 1.0 HRS ARR	(OL)	Keenan,D	ONLINE
Transferable to UC, CSU (CAN ECON 2)					27734	3.0 HRS ARR	(OL)	Merino-Hernandez,H	ONLINE
Prerequisite: MATH 40 or equivalent with a grade of "C" or higher or "Pass" or completion of the Math Placement Process with a score eligible for MATH 60.						Note: For class information and orientation go to Canvas.			
Recommendation: ENGL 100 or ENGL 100S or equivalent with a grade of "C" or higher or "Pass".						+ 1.0 HRS ARR	(OL)	Merino-Hernandez,H	ONLINE
<b>21833</b>	<b>6:00- 9:00PM</b>	<b>Th</b>	Tahernia,F	REMOTE	27149	3.0 HRS ARR	(OL)	Chi,W	ONLINE
	<b>9:00- 9:50PM</b>	<b>Th</b>	Tahernia,F	REMOTE		+ 1.0 HRS ARR	(OL)	Chi,W	ONLINE
21837	3.0 HRS ARR	(OL)	Keenan,D	ONLINE	30377	3.0 HRS ARR	(OL)	De Los Rios,K	ONLINE
	Note: For class information and orientation go to Canvas.					+ 1.0 HRS ARR	(OL)	De Los Rios,K	ONLINE
	+ 1.0 HRS ARR	(OL)	Keenan,D	ONLINE	27738	3.0 HRS ARR	(OL)	Smith,S	ONLINE
24448	3.0 HRS ARR	(OL)	Merino-Hernandez,H	ONLINE		Note: For class information and orientation go to Canvas.			
	+ 1.0 HRS ARR	(OL)	Merino-Hernandez,H	ONLINE		+ 1.0 HRS ARR	(OL)	Smith,S	ONLINE
26547	3.0 HRS ARR	(OL)	Chi,W	ONLINE	29534	3.0 HRS ARR	(OL)	Chi,W	ONLINE
	+ 1.0 HRS ARR	(OL)	Chi,W	ONLINE		+ 1.0 HRS ARR	(OL)	Chi,W	ONLINE
27256	3.0 HRS ARR	(OL)	Vayo II,L	ONLINE	<b>25671</b>	<b>6:00- 9:30PM</b>	<b>W</b>	Namala,S	REMOTE
	Note: For class information and orientation go to Canvas.					<b>9:30-10:50PM</b>	<b>W</b>	Namala,S	REMOTE
	+ 1.0 HRS ARR	(OL)	Vayo II,L	ONLINE		Class# 25671 meets 08/19/2020-11/25/2020			
27730	3.0 HRS ARR	(OL)	Yilan,L	ONLINE	<b>30035</b>	<b>6:00- 9:00PM</b>	<b>T</b>	Lee,H	REMOTE
	Note: For class information and orientation go to Canvas.					<b>9:00- 9:50PM</b>	<b>T</b>	Lee,H	REMOTE
	+ 1.0 HRS ARR	(OL)	Yilan,L	ONLINE		Class# 30035 meets 09/08/2020-12/15/2020			
29530	3.0 HRS ARR	(OL)	Chi,W	ONLINE	22624	11:00- 2:00PM	MW	Namala,S	REMOTE
	+ 1.0 HRS ARR	(OL)	Chi,W	ONLINE		2:00- 2:50PM	MW	Namala,S	REMOTE
27011	11:00- 2:00PM	MW	Namala,S	REMOTE		Class# 22624 meets 10/19/2020-12/06/2020			
	2:00- 2:50PM	MW	Namala,S	REMOTE	<b>ECON 202M - 3.0 UNITS PRINCIPLES OF MICROECONOMICS</b>				
	Class# 27011 meets 08/17/2020-10/14/2020				Transferable to UC, CSU				
					Prerequisite: MATH 60 or equivalent with a grade of "C" or higher or "Pass" or completion of the assessment/placement process with eligibility for MATH 80 or MATH 80A or higher.				
					Recommendation: ENGL 100 or ENGL 100S or equivalent with a grade of "C" or higher or "Pass".				
27740	3.0 HRS ARR	(OL)	Keenan,D	ONLINE	27740	3.0 HRS ARR	(OL)	Keenan,D	ONLINE
	Note: For class information and orientation go to Canvas.					+ 1.0 HRS ARR	(OL)	Keenan,D	ONLINE
	+ 1.0 HRS ARR	(OL)	Keenan,D	ONLINE	23778	3.0 HRS ARR	(OL)	Smith,S	ONLINE
	+ 1.0 HRS ARR	(OL)	Keenan,D	ONLINE		Note: For class information and orientation go to Canvas.			
	+ 1.0 HRS ARR	(OL)	Keenan,D	ONLINE		+ 1.0 HRS ARR	(OL)	Smith,S	ONLINE

If a class displays as **REMOTE** in the schedule, students will be expected to log into the class at a specified day/time (e.g., MW 8-9:15am). If the class displays as **ONLINE** in the schedule, students are permitted to log into the class whenever they are available to complete coursework by the established deadlines.

Students not in attendance or late for the first class meeting are subject to drop.

Class#	Time	Day	Instructor	Room	Class#	Time	Day	Instructor	Room
27736	3.0 HRS ARR	(OL)	Merino-Hernandez,H	ONLINE					
	Note: For class information and orientation go to Canvas.								
	+ 1.0 HRS ARR	(OL)	Merino-Hernandez,H	ONLINE					
30379	3.0 HRS ARR	(OL)	De Los Rios,K	ONLINE					
	+ 1.0 HRS ARR	(OL)	De Los Rios,K	ONLINE					
27136	3.0 HRS ARR	(OL)	Chi,W	ONLINE					
	+ 1.0 HRS ARR	(OL)	Chi,W	ONLINE					
29536	3.0 HRS ARR	(OL)	Chi,W	ONLINE					
	+ 1.0 HRS ARR	(OL)	Chi,W	ONLINE					
<b>25673</b>	<b>6:00- 9:30PM</b>	<b>W</b>	Namala,S	REMOTE					
	<b>9:30-10:50PM</b>	<b>W</b>	Namala,S	REMOTE					
	Class# 25673 meets 08/19/2020-11/25/2020								
<b>30037</b>	<b>6:00- 9:00PM</b>	<b>T</b>	Lee,H	REMOTE					
	<b>9:00- 9:50PM</b>	<b>T</b>	Lee,H	REMOTE					
	Class# 30037 meets 09/08/2020-12/15/2020								
22634	11:00- 2:00PM	MW	Namala,S	REMOTE					
	2:00- 2:50PM	MW	Namala,S	REMOTE					
	Class# 22634 meets 10/19/2020-12/06/2020								

## EDUCATION

### EDEL 100 - 1.0 UNIT INTRODUCTION TO TEACHING AND LEARNING IN DIVERSE CONTEMPORAR

Transferable to CSU

21425	1.2 HRS ARR	(OL)	Fonti,A	ONLINE
Targeted for Future Teachers but Open to all Students				
Class# 21425 meets 09/08/2020-12/18/2020				

29123	1.2 HRS ARR	(OL)	Morales,X	ONLINE
*Orientation will be entirely online. Instructor will email course information and provide access to the course a week prior to the start of the semester. Additional information will also be posted in Canvas, which can be accessed through the Cerritos College website. Students must access the course online by midnight on the first day of class. To prevent being dropped from the course, students must access the course by the first week of the semester. Waitlist students will be emailed by instructor if they can be added.;Targeted for Future Teachers but Open to all Students				
Class# 29123 meets 09/08/2020-12/18/2020				

29754	1.2 HRS ARR	(OL)	Morales,X	ONLINE
Note: Orientation will be entirely online. Instructor will email course information and provide access to the course a week prior to the start of the semester. Additional information will also be posted in Canvas, which can be accessed through the Cerritos College website. Students must access the course online by midnight on the first day of class. To prevent being dropped from the course, students must access the course by the first week of the semester. Waitlist students will be emailed by instructor if they can be added.				
Class# 29754 meets 09/08/2020-12/18/2020				

### EDEL 200 - 3.0 UNITS INTRODUCTION TO THE TEACHING PROFESSION

Transferable to CSU

Prerequisite: EDEL100 or equivalent, AND ENGL 100 or ENGL 100S or equivalent, AND MATH 70 or Math 80 or equivalent, with a grade of "C" or higher or "Pass", OR completion of the assessment/placement with eligibility for MATH 110A.

25504	3.0 HRS ARR	(OL)	Fonti,A	REMOTE
In order to complete the fieldwork requirement for EDEL 200, student must complete the mandatory online training on Friday, September 11th from 9:00-12:00 pm. Details about logging into the training will be shared by the instructor and Teacher TRAC program.				
STUDENTS MUST BE ACCEPTED INTO THE TEACHER TRAC PROGRAM.				
Applications for fall 2020 admissions are due no later than August 28, 2020. To apply, please visit the Teacher TRAC website at <a href="http://www.teachertrac.com">www.teachertrac.com</a> where you will find the application and instructions.				
For more information please call (562) 860-2451, ext. 2212 or email <a href="mailto:teachertrac@cerritos.edu">teachertrac@cerritos.edu</a>				

## EDUCATIONAL TECHNOLOGY (EDTCH)

### EDT 110 - 2.0 UNITS INTRODUCTION TO EDUCATIONAL TECHNOLOGY

Transferable to CSU

29441	2.4 HRS ARR	(OL)	Rheaume,L	ONLINE
	2:20- 3:30PM	(OL)	Rheaume,L	ONLINE
Class# 29441 meets 09/08/2020-12/18/2020				
22293	4.0 HRS ARR	(OL)	Alexander,C	ONLINE
Targeted for Future Teachers but Open to all Students				
	+ 2.0 HRS ARR	(OL)	Alexander,C	ONLINE
Targeted for Future Teachers but Open to all Students				
Class# 22293 meets 08/17/2020-10/16/2020				
24172	4.0 HRS ARR	(OL)	Alexander,C	ONLINE
	+ 2.0 HRS ARR	(OL)	Alexander,C	ONLINE
Course reserved for Middle College Scholars Academy				
Class# 24172 meets 08/17/2020-10/16/2020				

### EDT 125 - 2.0 UNITS FUNDAMENTALS OF ONLINE TEACHING

Transferable to CSU

Recommendation: EDT 50 or EDT 151 or equivalent with a grade of "C" or higher or "Pass."

21249	4.0 HRS ARR	(OL)	Alexander,C	ONLINE
Orientation will be conducted online. Instructor will email students with instructions prior to the start of the class.				
Class# 21249 meets 10/19/2020-12/18/2020				

### EDT 132 - 2.0 UNITS USING AUDIO IN THE CLASSROOM

Transferable to CSU

Recommendation: EDT 50 or EDT 151 or equivalent with a grade of "C" or higher or "Pass."

30023	4.0 HRS ARR	(OL)	Rodriguez,C	ONLINE
Orientation will be conducted online. Instructor will email students with instructions prior to the start of the class.				
Class# 30023 meets 10/19/2020-12/18/2020				

### EDT 135 - 3.0 UNITS SLIDE PRESENTATION SOFTWARE FOR EDUCATORS

Transferable to CSU

Recommendation: EDT 50 or EDT 151 or equivalent with a grade of "C" or higher or "Pass."

30024	6.0 HRS ARR	(OL)	Alexander,C	ONLINE
Orientation will be conducted online. Instructor will email students with instructions prior to the start of the class.				
Class# 30024 meets 08/17/2020-10/16/2020				

### EDT 139 - 2.0 UNITS E-PORTFOLIOS FOR EDUCATION

Transferable to CSU

Recommendation: EDT 50 or EDT 151 or equivalent with a grade of "C" or higher or "Pass."

30025	4.0 HRS ARR	(OL)	Morgan,V	ONLINE
Orientation will be conducted online. Instructor will email students with instructions prior to the start of the class.				
Class# 30025 meets 10/19/2020-12/18/2020				

### EDT 141 - 2.0 UNITS WEB DESIGN FOR EDUCATORS

Transferable to CSU

Recommendation: EDT 50 or EDT 151 or equivalent with a grade of "C" or higher or "Pass."

30026	4.0 HRS ARR	(OL)	Alexander,C	ONLINE
Orientation will be conducted online. Instructor will email students with instructions prior to the start of the class.				
Class# 30026 meets 10/19/2020-12/18/2020				

## ENGINEERING

### ENGR 110 - 2.0 UNITS INTRODUCTION TO ENGINEERING

Transferable to UC, CSU

25396	1:00- 2:50PM	F	Wong,K	REMOTE
<b>26448</b>	<b>7:00- 8:50PM</b>	<b>Th</b>	Wong,K	REMOTE

If a class displays as **REMOTE** in the schedule, students will be expected to log into the class at a specified day/time (e.g., MW 8-9:15am). If the class displays as **ONLINE** in the schedule, students are permitted to log into the class whenever they are available to complete coursework by the established deadlines.

Students not in attendance or late for the first class meeting are subject to drop.

Class#	Time	Day	Instructor	Room	Class#	Time	Day	Instructor	Room
<b>ENGR 112 - 3.0 UNITS ENGINEERING GRAPHICS</b> Transferable to UC, CSU (CAN ENGR 2) Prerequisite: MATH 140 or equivalent with a grade of "C" or higher or "Pass." Note: All class information will be available online via Canvas. Students will need to download and install free AutoDesk, AutoCAD, and AutoDesk Inventor software, links provided on Canvas. Email address: abakalyar@ceritos.edu.					<b>ENGT 259 - 4.0 UNITS SOLIDWORKS INTRODUCTION</b> Transferable to CSU NOTE: a material fee of \$10.00 is required for ENGT 259				
28148	2.0 HRS ARR	(OL)	Bakalyar,A	ONLINE	24245	3.0 HRS ARR	(OL)	Micic,M	ONLINE
						+ 3.0 HRS ARR	(OL)	Micic,M	ONLINE
<b>ENGR 220 - 3.0 UNITS PROGRAMMING AND PROBLEM-SOLVING IN MATLAB</b> Transferable to UC, CSU Prerequisite: Math 170 or equivalent with a grade of "C" or higher or "Pass".					<b>ENGT 260 - 4.0 UNITS ADVANCED MODELING USING SOLIDWORKS</b> Transferable to CSU Prerequisite: ENGT 259 or equivalent with a grade of Pass or "C" or higher, or appropriate work experience. NOTE: a material fee of \$10.00 is required for ENGT 260				
30579	12:20- 1:30PM	TTh	Kemp,R	REMOTE	28956	3.0 HRS ARR	(OL)	Micic,M	ONLINE
	1:30- 2:40PM	TTh	Kemp,R	REMOTE		+ 3.0 HRS ARR	(OL)	Micic,M	ONLINE
<b>ENGR 235 - 3.0 UNITS STATICS</b> Transferable to UC, CSU (CAN ENGR 8) Prerequisite: MATH 190 and PHYS 201 or equivalents with grades of "C" or higher or "Pass."									
27060	3.0 HRS ARR	(OL)	Bakalyar,A	ONLINE					

## ENGINEERING DESIGN TECHNOLOGY

### ENGT 103 - 3.0 UNITS INTRODUCTION TO ENGINEERING DESIGN USING INVENTOR

Transferable to CSU  
 NOTE: a material fee of \$10.00 is required for ENGT 103  
 Please read the technical standards relevant to this department at <http://cms.ceritos.edu/technology/standards.htm>

24237	2.4 HRS ARR	(OL)	Jamka,A	ONLINE
	+ 3.6 HRS ARR	(OL)	Jamka,A	ONLINE
Class# 24237 meets 09/08/2020-12/18/2020				

### ENGT 116 - 2.0 UNITS BLUEPRINT READING

Transferable to CSU  
 Recommendation: ENGT 131 or equivalent with a grade of Pass or "C" or higher.

21468	1.5 HRS ARR	(OL)	Li,D	ONLINE
	+ 1.5 HRS ARR	(OL)	Li,D	ONLINE
28411	3.0 HRS ARR	(OL)	Li,D	ONLINE
	+ 3.0 HRS ARR	(OL)	Li,D	ONLINE
Class# 28411 meets 10/19/2020-12/18/2020				

### ENGT 117 - 2.0 UNITS GEOMETRICAL DIMENSIONING AND TOLERANCING

Transferable to CSU  
 Corequisite: ENGT 116 or equivalent with a grade of Pass or "C" or higher or prior completion.

26136	4.0 HRS ARR	(OL)	Real,Y	ONLINE
Class# 26136 meets 08/17/2020-10/16/2020				

### ENGT 131 - 3.0 UNITS DESIGN FUNDAMENTALS INCLUDING 3D MODELING

Transferable to CSU  
 Recommendation: ENGT 116 or equivalent with a grade of "C" or higher, or "Pass."

28039	2.0 HRS ARR	(OL)	Li,D	ONLINE
	+ 4.0 HRS ARR	(OL)	Li,D	ONLINE

### ENGT 139 - 4.0 UNITS CLOUD BASED 3D MODELING WITH ONSHAPE

Transferable to CSU

30005	3.0 HRS ARR	(OL)	Micic,M	ONLINE
	+ 3.0 HRS ARR	(OL)	Micic,M	ONLINE

### ENGT 258 - 4.0 UNITS TOOLS AND FIXTURES APPLICATIONS USING SOLID MODELING

Transferable to CSU  
 Prerequisite: ENGT 103, or ENGT 138, or ENGT 259, or ENGT 265 or equivalent with a grade of "C" or higher, or "Pass."  
 NOTE: a material fee of \$10.00 is required for ENGT 258

30007	3.0 HRS ARR	(OL)	Li,D	ONLINE
	+ 3.0 HRS ARR	(OL)	Li,D	ONLINE

## ENGINEERING TECHNOLOGY

### ET 101 - 3.0 UNITS PRINCIPLES OF ENGINEERING TECHNOLOGY

Transferable to CSU  
 NOTE: a material fee of \$10.00 is required for ET 101  
 Please read the technical standards relevant to this department at <http://cms.ceritos.edu/technology/standards.htm>

22684	2.0 HRS ARR	(OL)	Jamka,A	ONLINE
	+ 3.0 HRS ARR	(OL)	Jamka,A	ONLINE

## ENGLISH

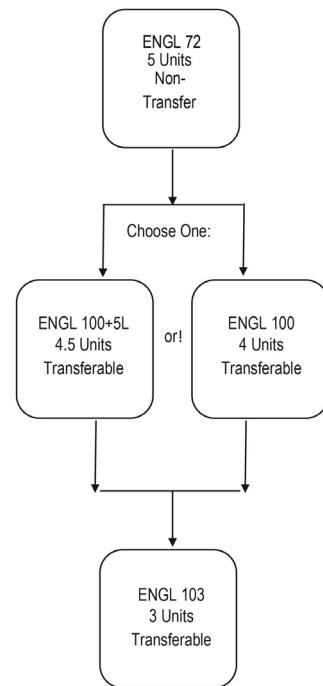

English 100, Freshman Composition, is required for transfer and for A.A. degrees. The English writing classes above help you to achieve those goals.

If you previously placed in English 20, English 72 is now the place to start. Students who were placed in English 52 or who passed English 20 with a C or better may take English 100+5L. This class adds a lab component to the Freshman Composition class to provide extra support for students as they complete their transfer requirement.

Both English 100+5L and English 100 complete the transfer and A.A. degree requirement; students need only take one of those courses. Students whose transfer goals require a critical thinking class may take English 103 after they pass Freshman Composition successfully.

If a class displays as **REMOTE** in the schedule, students will be expected to log into the class at a specified day/time (e.g., MW 8-9:15am). If the class displays as **ONLINE** in the schedule, students are permitted to log into the class whenever they are available to complete coursework by the established deadlines.

Students not in attendance or late for the first class meeting are subject to drop.

Class#	Time	Day	Instructor	Room	Class#	Time	Day	Instructor	Room
<b>ENGL 72 - 5.0 UNITS INTRODUCTION TO COLLEGE WRITING AND REASONING</b>									
Not Transferable									
Prerequisite: Completion of ENGL 20 or equivalent with a grade of "C" or higher, or of "Pass", or completion of the placement process with eligibility for ENGL 20 or ENGL 52.									
29645	30677 1:00-3:00 PM		TR HAMMOND, R.	REMOTE	24540	4.0 HRS ARR	(OL)	Russell,C	ONLINE
	30678 3:00-3:50 PM		TR HAMMOND, R	REMOTE	24595	4.0 HRS ARR	(OL)	Fagundes,M	ONLINE
Note: President's Scholar Academy									
<b>ENGL 100 - 4.0 UNITS FRESHMAN COMPOSITION</b>									
Transferable to UC, CSU (CAN ENGL 2)									
Prerequisite: Prerequisite: ENGL 52 or ENGL 72 or ESL 152 or equivalent with a grade of "C" or higher, or of "Pass", or completion of the assessment/placement process with eligibility for ENGL 100 or ENGL 100S.									
20185	4.0 HRS ARR	(OL)	Clifford,S	ONLINE	27865	4.0 HRS ARR	(OL)	Mitchell-Lambert,J	ONLINE
MANDATORY ORIENTATION: All enrolled students must complete the online orientation that is located on Canvas to remain enrolled in this course.					This ENGL 100 class is part of the Health Occupations House in the First Year Experience Program, which includes COUN 200 (#22518), MATH 5 (#29045), MATH 112 (#20339), and SOC 101 (#20550). To learn more about FYE and to enroll in this house, please visit <a href="https://www.cerritos.edu/lcp/fye.htm">https://www.cerritos.edu/lcp/fye.htm</a> .				
20191	4.0 HRS ARR	(OL)	Kayser,L	ONLINE	26400	4.0 HRS ARR	(OL)	Shah,N	ONLINE
MANDATORY ORIENTATION: All enrolled students must complete the online orientation that is located on Canvas to remain enrolled in this course.					27867	4.0 HRS ARR	(OL)	Nishimura,M	ONLINE
Targeted for Future Teachers but Open to all Students					26402	4.0 HRS ARR	(OL)	Quaas-Berryman,F	ONLINE
20192	4.0 HRS ARR	(OL)	Sartin,N	ONLINE	25967	4.0 HRS ARR	(OL)	STAFF	ONLINE
NOTE: The overarching themes for this course are cultural, class, and gender inequalities. Most all of the assigned readings are written by women and ethnic writers.					25969	4.0 HRS ARR	(OL)	Cagnolatti,D	ONLINE
20194	4.0 HRS ARR	(OL)	Granillo,C	ONLINE	MANDATORY ORIENTATION: All enrolled students must complete the online orientation that is located on Canvas to remain enrolled in this course.				
20196	4.0 HRS ARR	(OL)	Stanfield,S	ONLINE	26403	4.0 HRS ARR	(OL)	STAFF	ONLINE
30157	4.0 HRS ARR	(OL)	Pelonis,C	ONLINE	A PORTION OF THE HOURS FOR THIS CLASS WILL BE ONLINE.				
MANDATORY ORIENTATION: All enrolled students must complete the online orientation that is located on Canvas to remain enrolled in this course.					26404	4.0 HRS ARR	(OL)	Quaas-Berryman,F	ONLINE
20204	4.0 HRS ARR	(OL)	Fagundes,M	ONLINE	A PORTION OF THE HOURS FOR THIS CLASS WILL BE ONLINE.				
20205	4.0 HRS ARR	(OL)	Russell,C	ONLINE	26405	4.0 HRS ARR	(OL)	Gaik,F	ONLINE
20206	4.0 HRS ARR	(OL)	Nishimura,M	ONLINE	21289	4.0 HRS ARR	(OL)	Ludvigsen,L	ONLINE
20208	4.0 HRS ARR	(OL)	Kessworth,B	ONLINE	26456	4.0 HRS ARR	(OL)	McGaw,M	ONLINE
20688	4.0 HRS ARR	(OL)	Kayser,L	ONLINE	26457	4.0 HRS ARR	(OL)	Greene,C	ONLINE
MANDATORY ORIENTATION: All enrolled students must complete the online orientation that is located on Canvas to remain enrolled in this course.					A PORTION OF THE HOURS FOR THIS CLASS WILL BE ONLINE.				
20689	4.0 HRS ARR	(OL)	Shah,N	ONLINE	26458	4.0 HRS ARR	(OL)	Hulett,O	ONLINE
MANDATORY ORIENTATION: All enrolled students must complete the online orientation that is located on Canvas to remain enrolled in this course.					26511	4.0 HRS ARR	(OL)	Dongell,R	ONLINE
20690	9:00-10:50AM	(OL)	Quaas-Berryman,F	ONLINE	<b>22736</b>	<b>6:00- 7:50PM</b>	<b>MW</b>	Vang,B	REMOTE
22150	1:00- 2:50PM		Nave,M	REMOTE	27318	4.0 HRS ARR	(OL)	Hiza,J	ONLINE
22074	7:00- 8:50AM		Gaik,F	ONLINE	27319	9:00-12:50PM	F	Arambula,M	REMOTE
22345	4.0 HRS ARR	(OL)	Shah,N	ONLINE	27375	4.0 HRS ARR	(OL)	Stansbury,D	ONLINE
MANDATORY ORIENTATION: All enrolled students must complete the online orientation that is located on Canvas to remain enrolled in this course.					28702	4.0 HRS ARR	(OL)	Smith,S	ONLINE
24537	4.0 HRS ARR	(OL)	Sandoval,A	ONLINE	30396	4.0 HRS ARR	(OL)	Leis,C	ONLINE
30090	4.0 HRS ARR	(OL)	Quaas-Berryman,F	ONLINE	27868	4.0 HRS ARR	(OL)	Brashear,N	ONLINE
26396	4.0 HRS ARR	(OL)	Sartin,N	ONLINE	27869	4.0 HRS ARR	(OL)	Bielik,N	ONLINE
NOTE: The overarching themes for this course are cultural, class, and gender inequalities. Most all of the assigned readings are written by women and ethnic writers.					27871	4.0 HRS ARR	(OL)	Cristin,S	ONLINE
20197	4.0 HRS ARR	(OL)	Stansbury,D	ONLINE	This ENGL 100 class is part of the Psychology House in the First Year Experience Program, which includes PSYC 101 (#20504), PSYC 210 (#29104), PSYC 210 LAB, and READ 101 (#30187). To learn more about FYE and to enroll in this house, please visit <a href="https://www.cerritos.edu/lcp/fye.htm">https://www.cerritos.edu/lcp/fye.htm</a> .				
20198	4.0 HRS ARR	(OL)	Cole,E	ONLINE	27873	4.0 HRS ARR	(OL)	Reyes,A	ONLINE
MANDATORY ORIENTATION: All enrolled students must complete the online orientation that is located on Canvas to remain enrolled in this course.					27874	4.0 HRS ARR	(OL)	Morrison,A	ONLINE
23986	4.0 HRS ARR	(OL)	Hiza,J	ONLINE	27875	4.0 HRS ARR	(OL)	Hulett,O	ONLINE
20201	1:00- 2:50PM	(OL)	Reyes,A	ONLINE	29171	7:00- 8:50AM	MW	STAFF	REMOTE
20202	4.0 HRS ARR	(OL)	Sartin,N	ONLINE	<b>29189</b>	<b>7:00- 8:50PM</b>	<b>MW</b>	Rios,R	REMOTE
NOTE: The overarching themes for this course are cultural, class, and gender inequalities. Most all of the assigned readings are written by women and ethnic writers.					27878	4.0 HRS ARR	(OL)	Quaas-Berryman,F	ONLINE
20203	4.0 HRS ARR	(OL)	Shah,N	ONLINE	MANDATORY ORIENTATION: All enrolled students must complete the online orientation that is located on Canvas to remain enrolled in this course.				
27317	2:00- 3:50PM	MW	STAFF	REMOTE	29192	4.0 HRS ARR	(OL)	Clifford,S	ONLINE
27247	4.0 HRS ARR	(OL)	Sartin,N	ONLINE	MANDATORY ORIENTATION: All enrolled students must complete the online orientation that is located on Canvas to remain enrolled in this course.				
NOTE: The overarching themes for this course are cultural, class, and gender inequalities. Most all of the assigned readings are written by women and ethnic writers.					27881	1:00- 2:50PM	MW	Arambula,M	REMOTE
22297	4.0 HRS ARR	(OL)	Hammond,R	ONLINE	29197	4.0 HRS ARR	(OL)	Lefebvre,L	ONLINE
26510	4.0 HRS ARR	(OL)	Fagundes,M	ONLINE	29198	4.0 HRS ARR	(OL)	Leis,C	ONLINE
This ENGL 100 class is part of the Arts, Humanities, & Communication House in the First Year Experience Program, which includes COUN 200 (#30497), MATH 5 (#29060), and MATH 112 (#24343). To learn more about FYE and to enroll in this house, please visit <a href="https://www.cerritos.edu/lcp/fye.htm">https://www.cerritos.edu/lcp/fye.htm</a> .					29199	1:00- 2:50PM	TTh	Miranda,V	REMOTE
					27885	4:00- 5:50PM	MW	Zamora,V	REMOTE
					29200	1:00- 2:50PM	TTh	DeFrance,R	REMOTE
					29202	4.0 HRS ARR	(OL)	Mata,C	ONLINE
					29203	3:00- 4:50PM	TTh	Miranda,V	REMOTE
					27889	8:00- 9:50AM	TTh	Crum,A	REMOTE
					29206	4.0 HRS ARR	(OL)	Dongell,R	ONLINE
					27892	12:00- 1:50PM	TTh	Kessworth,B	REMOTE
					27893	11:00-12:50PM	TTh	Crum,A	REMOTE
					29209	4.0 HRS ARR	(OL)	Palencia,M	ONLINE
					29211	4.0 HRS ARR	(OL)	Greene,C	ONLINE
					27896	4.0 HRS ARR	(OL)	Mata,C	ONLINE
					29438	4.0 HRS ARR	(OL)	Lefebvre,L	ONLINE
					30645	9:00-10:50AM	MW	Cristin,S	REMOTE
					27905	4.0 HRS ARR	(OL)	Walsh,W	ONLINE
					29793	4.0 HRS ARR	(OL)	STAFF	ONLINE
					MANDATORY ORIENTATION: All enrolled students must complete the online orientation that is located on Canvas to remain enrolled in this course.				
					27907	12:00- 1:50PM	MW	STAFF	REMOTE
					27909	4.0 HRS ARR	(OL)	Estrada,D	ONLINE
					20193	4.8 HRS ARR	(OL)	Juntilla,T	ONLINE
					Class# 20193 meets 08/17/2020-11/27/2020				
					26399	4.8 HRS ARR	(OL)	Juntilla,T	ONLINE
					Class# 26399 meets 08/17/2020-11/25/2020				

If a class displays as **REMOTE** in the schedule, students will be expected to log into the class at a specified day/time (e.g., MW 8-9:15am). If the class displays as **ONLINE** in the schedule, students are permitted to log into the class whenever they are available to complete coursework by the established deadlines.

Students not in attendance or late for the first class meeting are subject to drop.



Class#	Time	Day	Instructor	Room	Class#	Time	Day	Instructor	Room
27316	4.8 HRS ARR	(OL)	Estrada,D	ONLINE	30137	3:00- 6:50PM	MW	STAFF	REMOTE
	Class# 27316 meets 09/08/2020-12/18/2020					Class# 30137 meets 08/17/2020-10/14/2020			
30159	4.8 HRS ARR	(OL)	Amano-Tompkins,T	ONLINE	30139	3:00- 6:50PM	TTh	Tamayo,K	REMOTE
	MANDATORY ORIENTATION: All enrolled students must complete the online orientation that is located on Canvas to remain enrolled in this course.					Class# 30139 meets 08/18/2020-10/15/2020			
	Class# 30159 meets 09/08/2020-12/18/2020				30138	3:00- 6:50PM	MW	Kalt,K	REMOTE
	Class# 30159 meets 09/08/2020-12/18/2020					Class# 30138 meets 10/19/2020-12/06/2020			
23466	4.8 HRS ARR	(OL)	Blake,L	ONLINE	30140	3:00- 6:50PM	TTh	Tamayo,K	REMOTE
	MANDATORY ORIENTATION: All enrolled students must complete the online orientation that is located on Canvas to remain enrolled in this course.					Class# 30140 meets 10/20/2020-12/17/2020			
	Class# 23466 meets 09/08/2020-12/18/2020					<b>ENGL 100S - 4.5 UNITS ENHANCED FRESHMAN COMPOSITION</b>			
30392	4.8 HRS ARR	(OL)	Ali,J	ONLINE		Transferable to UC, CSU			
	MANDATORY ORIENTATION: All enrolled students must complete the online orientation that is located on Canvas to remain enrolled in this course.					Prerequisite: ENGL 52 or ENGL 72 or ESL 152 or equivalent with a grade of "C" or higher or "Pass" or completion of the current English placement process with eligibility for ENGL 52 or ENGL72.			
	Class# 30392 meets 09/08/2020-12/18/2020				30068	4.0 HRS ARR	(OL)	Cole,E	ONLINE
30397	12:00- 2:10PM	TTh	Lamas,C	REMOTE		+ 2.0 HRS ARR	(OL)	Cole,E	ONLINE
	Class# 30397 meets 09/08/2020-12/18/2020				30074	4.0 HRS ARR	(OL)	Reeves,M	ONLINE
28236	4.8 HRS ARR	(OL)	STAFF	ONLINE		+ 2.0 HRS ARR	(OL)	Reeves,M	ONLINE
	MANDATORY ORIENTATION: All enrolled students must complete the online orientation that is located on Canvas to remain enrolled in this course.				30076	4.0 HRS ARR	(OL)	Blake,L	ONLINE
	Class# 28236 meets 09/08/2020-12/18/2020					+ 2.0 HRS ARR	(OL)	Blake,L	ONLINE
29746	4.8 HRS ARR	(OL)	Bran,B	ONLINE	30078	4.0 HRS ARR	(OL)	Graniillo,C	ONLINE
	Class# 29746 meets 09/08/2020-12/18/2020					+ 2.0 HRS ARR	(OL)	Graniillo,C	ONLINE
29796	4.8 HRS ARR	(OL)	Avalos,B	ONLINE	30084	4.0 HRS ARR	(OL)	Cagnolatti,D	ONLINE
	Class# 29796 meets 09/08/2020-12/17/2020					+ 2.0 HRS ARR	(OL)	Cagnolatti,D	ONLINE
22346	8.0 HRS ARR	(OL)	Kalt,K	ONLINE	30086	4.0 HRS ARR	(OL)	Alvarez,L	ONLINE
	MANDATORY ORIENTATION: All enrolled students must complete the online orientation that is located on Canvas to remain enrolled in this course.					+ 2.0 HRS ARR	(OL)	Alvarez,L	ONLINE
	Class# 22346 meets 08/17/2020-10/16/2020				30088	4.0 HRS ARR	(OL)	Olague,M	ONLINE
22452	8.0 HRS ARR	(OL)	Cheatham,T	ONLINE		+ 2.0 HRS ARR	(OL)	Olague,M	ONLINE
	Class# 22452 meets 08/17/2020-10/16/2020				30091	1:00- 2:50PM	MW	Danielo,J	REMOTE
24542	8.0 HRS ARR	(OL)	Gonzales,J	ONLINE		3:00- 3:50PM	MW	Danielo,J	REMOTE
	MANDATORY ORIENTATION: All enrolled students must complete the online orientation that is located on Canvas to remain enrolled in this course.				30093	4.0 HRS ARR	(OL)	Alvarez,L	ONLINE
	Class# 24542 meets 08/17/2020-10/16/2020					+ 2.0 HRS ARR	(OL)	Alvarez,L	ONLINE
24115	8.0 HRS ARR	(OL)	Cheatham,T	ONLINE	30095	4.0 HRS ARR	(OL)	Gardner, D (PUENTE)	ONLINE
	Class# 24115 meets 08/17/2020-10/16/2020					This ENGL 100S class is part of the Puente Learning Community, which includes COUN 200 #22519. For additional information on PUENTE, please contact the program counselor/coordinator Gustavo Romero at gromero@cerritos.edu.			
21781	8.0 HRS ARR	(OL)	Ludvigsen,L	ONLINE		+ 2.0 HRS ARR	(OL)	Gardner, D (PUENTE)	ONLINE
	MANDATORY ORIENTATION: All enrolled students must complete the online orientation that is located on Canvas to remain enrolled in this course.				30101	4.0 HRS ARR	(OL)	Cagnolatti,D	ONLINE
	Class# 21781 meets 08/17/2020-10/16/2020					+ 2.0 HRS ARR	(OL)	Cagnolatti,D	ONLINE
30393	8.0 HRS ARR	(OL)	Asis,B	ONLINE	30103	4.0 HRS ARR	(OL)	Olague,M	ONLINE
	MANDATORY ORIENTATION: All enrolled students must complete the online orientation that is located on Canvas to remain enrolled in this course.					+ 2.0 HRS ARR	(OL)	Olague,M	ONLINE
	Class# 30393 meets 08/17/2020-10/16/2020				30105	4.0 HRS ARR	(OL)	Cole,E	ONLINE
30395	8.0 HRS ARR	(OL)	Vanciu,A	ONLINE		+ 2.0 HRS ARR	(OL)	Cole,E	ONLINE
	To remain enrolled in the course, you must complete the online orientation through Canvas by 11:59 pm on Monday AUG. 17th				30107	4.0 HRS ARR	(OL)	Walsh,W	ONLINE
	Class# 30395 meets 08/17/2020-10/16/2020					+ 2.0 HRS ARR	(OL)	Walsh,W	ONLINE
28817	8.0 HRS ARR	(OL)	Kalt,K	ONLINE	<b>30109</b>	<b>7:00- 8:50PM</b>	<b>TTh</b>	Crozier,J	REMOTE
	MANDATORY ORIENTATION: All enrolled students must complete the online orientation that is located on Canvas to remain enrolled in this course.					<b>9:00- 9:50PM</b>	<b>TTh</b>	Crozier,J	REMOTE
	Class# 28817 meets 08/17/2020-10/16/2020				30113	4.0 HRS ARR	(OL)	Morrison,A	ONLINE
25191	8.0 HRS ARR	(OL)	Kalt,K	ONLINE		+ 2.0 HRS ARR	(OL)	Morrison,A	ONLINE
	MANDATORY ORIENTATION: All enrolled students must complete the online orientation that is located on Canvas to remain enrolled in this course.				30115	4.0 HRS ARR	(OL)	Hicks,S	ONLINE
	Class# 25191 meets 10/19/2020-12/18/2020					+ 2.0 HRS ARR	(OL)	Hicks,S	ONLINE
30158	8.0 HRS ARR	(OL)	Asis,B	ONLINE	30117	4.0 HRS ARR	(OL)	Palencia,M	ONLINE
	MANDATORY ORIENTATION: All enrolled students must complete the online orientation that is located on Canvas to remain enrolled in this course.					+ 2.0 HRS ARR	(OL)	Palencia,M	ONLINE
	Class# 30158 meets 10/19/2020-12/18/2020				30119	4.0 HRS ARR	(OL)	McGaw,M	ONLINE
25091	8.0 HRS ARR	(OL)	Cheatham,T	ONLINE		+ 2.0 HRS ARR	(OL)	McGaw,M	ONLINE
	Targeted for Technology students but open to all.				30125	4.0 HRS ARR	(OL)	Alvarez,L	ONLINE
	Class# 25091 meets 10/19/2020-12/18/2020					+ 2.0 HRS ARR	(OL)	Alvarez,L	ONLINE
30394	8.0 HRS ARR	(OL)	Vanciu,A	ONLINE	30127	4.0 HRS ARR	(OL)	Pelonis,C	ONLINE
	MANDATORY ORIENTATION: All enrolled students must complete the online orientation that is located on Canvas to remain enrolled in this course.					+ 2.0 HRS ARR	(OL)	Pelonis,C	ONLINE
	Class# 30394 meets 10/19/2020-12/18/2020				30129	1:00- 2:50PM	TTh	Altebarmakian,T (HYBRID)	REMOTE
30398	8.0 HRS ARR	(OL)	Torres-Guimaraes,N	ONLINE		3:00- 3:50PM	TTh	Altebarmakian,T (HYBRID)	REMOTE
	To remain enrolled in the course, you must complete the online orientation through Canvas by 11:59 pm on Monday OCT. 19th				30131	1:00- 2:50PM	MW	Zamora,V	REMOTE
	Class# 30398 meets 10/19/2020-12/18/2020					3:00- 3:50PM	MW	Zamora,V	REMOTE
30160	8.0 HRS ARR	(OL)	STAFF	ONLINE	30141	4.0 HRS ARR	(OL)	Amano-Tompkins,T	ONLINE
	MANDATORY ORIENTATION: All enrolled students must complete the online orientation that is located on Canvas to remain enrolled in this course.					+ 2.0 HRS ARR	(OL)	Amano-Tompkins,T	ONLINE
	Class# 30160 meets 10/19/2020-12/18/2020				30146	4.0 HRS ARR	(OL)	Torres-Guimaraes,N	ONLINE
						+ 2.0 HRS ARR	(OL)	Torres-Guimaraes,N	ONLINE
					30148	4.0 HRS ARR	(OL)	Smith,S	ONLINE
						+ 2.0 HRS ARR	(OL)	Smith,S	ONLINE
					30150	4.0 HRS ARR	(OL)	Cepeda,M	ONLINE
						+ 2.0 HRS ARR	(OL)	Cepeda,M	ONLINE
					30154	4.0 HRS ARR	(OL)	Bran,B	ONLINE
						+ 2.0 HRS ARR	(OL)	Bran,B	ONLINE
					30070	4.8 HRS ARR	(OL)	Serwin,L	ONLINE
						+ 2.4 HRS ARR	(OL)	Serwin,L	ONLINE
						Class# 30070 meets 09/08/2020-12/18/2020			

If a class displays as **REMOTE** in the schedule, students will be expected to log into the class at a specified day/time (e.g., MW 8-9:15am). If the class displays as **ONLINE** in the schedule, students are permitted to log into the class whenever they are available to complete coursework by the established deadlines.

Students not in attendance or late for the first class meeting are subject to drop.

Class#	Time	Day	Instructor	Room	Class#	Time	Day	Instructor	Room
30072	4.8 HRS ARR + 2.4 HRS ARR	(OL) (OL)	Serwin,L Serwin,L	ONLINE ONLINE	27771	3.0 HRS ARR	(OL)	Whyngaught,J	ONLINE
Class# 30072 meets 09/08/2020-12/18/2020					27251	3.0 HRS ARR	(OL)	Mitchell-Lambert,J	ONLINE
30121	4.8 HRS ARR + 2.4 HRS ARR	(OL) (OL)	Serwin,L Serwin,L	ONLINE ONLINE	Targeted for Future Teachers but Open to all Students				
Class# 30121 meets 09/08/2020-12/18/2020					21605	3.0 HRS ARR	(OL)	Gil,N	ONLINE
30161	4.8 HRS ARR	(OL)	Lovejoy-Robold,N	ONLINE	26521	3:00- 4:15PM	TTh	Stavast,J	REMOTE
Targeted for Future Teachers but Open to all Students + 2.4 HRS ARR (OL) Lovejoy-Robold,N					27304	3.0 HRS ARR	(OL)	Whyngaught,J	ONLINE
Class# 30161 meets 09/08/2020-12/18/2020					30399	3.0 HRS ARR	(OL)	Carney,D	ONLINE
30163	4.8 HRS ARR	(OL)	Lovejoy-Robold,N	ONLINE	MANDATORY ORIENTATION: All enrolled students must complete the online orientation that is located on Canvas to remain enrolled in this course.				
Targeted for Future Teachers but Open to all Students Class# 30163 meets 09/08/2020-12/18/2020					24546	3.6 HRS ARR	(OL)	Clifford,S	ONLINE
30164	2.4 HRS ARR	(OL)	Lovejoy-Robold,N	ONLINE	MANDATORY ORIENTATION: All enrolled students must complete the online orientation that is located on Canvas to remain enrolled in this course.				
Class# 30164 meets 09/08/2020-12/18/2020					26408	3.6 HRS ARR	(OL)	Lovejoy-Robold,N	ONLINE
30080	8.0 HRS ARR + 4.0 HRS ARR	(OL) (OL)	Gonzales,J Gonzales,J	ONLINE ONLINE	MANDATORY ORIENTATION: All enrolled students must complete the online orientation that is located on Canvas to remain enrolled in this course.				
Class# 30080 meets 08/17/2020-10/16/2020					26413	3.0 HRS ARR	(OL)	Gil,N	ONLINE
30082	8.0 HRS ARR + 4.0 HRS ARR	(OL) (OL)	Gonzales,J Gonzales,J	ONLINE ONLINE	Class# 26413 meets 08/22/2020-12/12/2020				
Class# 30082 meets 10/19/2020-12/18/2020					30534	9:00-12:05PM	Sat	Walker,C	REMOTE
30097	8.0 HRS ARR + 4.0 HRS ARR	(OL) (OL)	Hua,L Hua,L	ONLINE ONLINE	Class# 30534 meets 08/22/2020-12/12/2020				
Class# 30097 meets 10/19/2020-12/18/2020					21474	6.0 HRS ARR	(OL)	Watnik,W	ONLINE
30099	8.0 HRS ARR + 4.0 HRS ARR	(OL) (OL)	Hua,L Hua,L	ONLINE ONLINE	MANDATORY ORIENTATION: All enrolled students must complete the online orientation that is located on Canvas to remain enrolled in this course.				
Class# 30099 meets 10/19/2020-12/18/2020					21476	6.0 HRS ARR	(OL)	Watnik,W	ONLINE
30123	8.0 HRS ARR + 4.0 HRS ARR	(OL) (OL)	Hua,L Hua,L	ONLINE ONLINE	MANDATORY ORIENTATION: All enrolled students must complete the online orientation that is located on Canvas to remain enrolled in this course.				
Class# 30123 meets 10/19/2020-12/18/2020					<b>ENGL 107 - 3.0 UNITS VOCABULARY BUILDING</b>				
<b>ENGL 102 - 3.0 UNITS INTRODUCTION TO LITERATURE</b>					Transferable to UC, CSU				
Transferable to UC, CSU (CAN ENGL 4)					25480	3.0 HRS ARR	(OL)	Carney,D	ONLINE
Prerequisite: ENGL 100 or ENGL 100S or equivalent with a grade of "C" or higher or "Pass".					MANDATORY ORIENTATION: All enrolled students must complete the online orientation that is located on Canvas to remain enrolled in this course.				
20210	3.0 HRS ARR	(OL)	STAFF	ONLINE	<b>ENGL 110 - 4.0 UNITS CRITICAL THINKING THROUGH LITERATURE</b>				
24543	3.0 HRS ARR	(OL)	Mitchell-Lambert,J	ONLINE	Transferable to UC, CSU				
Targeted for Future Teachers but Open to all Students					Prerequisite: ENGL 100 or ENGL 100S equivalent with a grade of "C" or higher or "Pass".				
24544	3.0 HRS ARR	(OL)	STAFF	ONLINE	29212	4.0 HRS ARR	(OL)	Gardner,D	ONLINE
27770	3.0 HRS ARR	(OL)	Mitchell-Lambert,J	ONLINE	29214	4.0 HRS ARR	(OL)	Avalos,B	ONLINE
MANDATORY ORIENTATION: All enrolled students must complete the online orientation that is located on Canvas to remain enrolled in this course.					29215	1:00- 2:50PM	TTh	Clifford,S	REMOTE
Targeted for Future Teachers but Open to all Students					30166	4.0 HRS ARR	(OL)	Mitchell-Lambert,J	ONLINE
29647	3.6 HRS ARR	(OL)	STAFF	ONLINE	MANDATORY ORIENTATION: All enrolled students must complete the online orientation that is located on Canvas to remain enrolled in this course.				
Class# 29647 meets 09/08/2020-12/18/2020					Targeted for Future Teachers but Open to all Students				
<b>ENGL 103 - 3.0 UNITS CRITICAL AND ARGUMENTATIVE WRITING</b>					30165	8.0 HRS ARR	(OL)	Cheatham,T	ONLINE
Transferable to UC, CSU					Class# 30165 meets 10/19/2020-12/18/2020				
Prerequisite: ENGL 100 or ENGL 100S or equivalent with a grade of "C" or higher or "Pass" or satisfactory completion of the Advanced Placement English Examination of the College Entrance Examination Board.					<b>ENGL 222 - 3.0 UNITS CHILDREN'S LITERATURE</b>				
26407	3.0 HRS ARR	(OL)	Stammler,C	ONLINE	Transferable to UC, CSU				
20212	3.0 HRS ARR	(OL)	Olague,M	ONLINE	Prerequisite: ENGL 52 or ENGL 72 or ESL 152 or equivalent with a grade of "C" or higher or "Pass", or completion of the English assessment/placement process with eligibility for ENGL 100 or ENGL 100S.				
22347	3.0 HRS ARR	(OL)	Krulic,J	ONLINE	26293	3.0 HRS ARR	(OL)	Cole,E	ONLINE
20213	3.0 HRS ARR	(OL)	Whyngaught,J	ONLINE	MANDATORY ORIENTATION: All enrolled students must complete the online orientation that is located on Canvas to remain enrolled in this course.				
22584	3.0 HRS ARR	(OL)	Stammler,C	ONLINE	<b>ENGL 225 - 3.0 UNITS MEXICAN LITERATURE IN TRANSLATION</b>				
22585	3.0 HRS ARR	(OL)	Cagnolatti,D	ONLINE	Transferable to UC, CSU				
MANDATORY ORIENTATION: All enrolled students must complete the online orientation that is located on Canvas to remain enrolled in this course.					Prerequisite: ENGL 52 or ENGL 72 or ESL 152 or equivalent with a grade of "C" or higher, or "Pass," or completion of the English assessment/placement process with eligibility for ENGL 100 or ENGL 100S.				
26414	3.0 HRS ARR	(OL)	Garcia,J	ONLINE	27773	3.6 HRS ARR	(OL)	Gardner,D	ONLINE
20215	3.0 HRS ARR	(OL)	Hicks,S	ONLINE	Class# 27773 meets 09/08/2020-12/18/2020				
20216	3.0 HRS ARR	(OL)	Krulic,J	ONLINE	<b>ENGL 228 - 3.0 UNITS SHAKESPEARE'S PLAYS</b>				
25970	3.0 HRS ARR	(OL)	Robles,A	ONLINE	Transferable to UC, CSU				
20217	3.0 HRS ARR	(OL)	Garcia,J	ONLINE	Prerequisite: ENGL 52 or ENGL 72 or ESL 152 or equivalent with a grade of "C" or higher or "Pass", or completion of the English assessment/placement process with eligibility for ENGL 100 or ENGL 100S.				
24545	3.0 HRS ARR	(OL)	Gil,N	ONLINE	25481	3.6 HRS ARR	(OL)	Gardner,D	ONLINE
21235	3.0 HRS ARR	(OL)	Olague,M	ONLINE	MANDATORY ORIENTATION: All enrolled students must complete the online orientation that is located on Canvas to remain enrolled in this course.				
21237	3.0 HRS ARR	(OL)	Watnik,W	ONLINE	Class# 25481 meets 09/08/2020-12/17/2020				
MANDATORY ORIENTATION: All enrolled students must complete the online orientation that is located on Canvas to remain enrolled in this course.					<b>ENGL 104 - 3.0 UNITS INTRODUCTION TO LITERATURE</b>				
30145	5:00- 6:15PM	TTh	STAFF	REMOTE	Transferable to UC, CSU				
22066	3.0 HRS ARR	(OL)	Mitchell-Lambert,J	ONLINE	Prerequisite: ENGL 100 or ENGL 100S or equivalent with a grade of "C" or higher or "Pass" or satisfactory completion of the Advanced Placement English Examination of the College Entrance Examination Board.				
Targeted for Future Teachers but Open to all Students					<b>ENGL 105 - 3.0 UNITS INTRODUCTION TO LITERATURE</b>				
24547	3.0 HRS ARR	(OL)	Cepeda,M	ONLINE	Transferable to UC, CSU				
30156	3.0 HRS ARR	(OL)	Garcia,J	ONLINE	Prerequisite: ENGL 100 or ENGL 100S or equivalent with a grade of "C" or higher or "Pass", or completion of the English assessment/placement process with eligibility for ENGL 100 or ENGL 100S.				
25971	9:00-11:50AM	F	Deon,L	REMOTE	MANDATORY ORIENTATION: All enrolled students must complete the online orientation that is located on Canvas to remain enrolled in this course.				
26409	3.0 HRS ARR	(OL)	Robles,A	ONLINE	Class# 25481 meets 09/08/2020-12/17/2020				

If a class displays as **REMOTE** in the schedule, students will be expected to log into the class at a specified day/time (e.g., MW 8-9:15am). If the class displays as **ONLINE** in the schedule, students are permitted to log into the class whenever they are available to complete coursework by the established deadlines.

Students not in attendance or late for the first class meeting are subject to drop.

Class#	Time	Day	Instructor	Room	Class#	Time	Day	Instructor	Room
--------	------	-----	------------	------	--------	------	-----	------------	------

**ENGL 230A - 3.0 UNITS INTRODUCTION TO AMERICAN LITERATURE**

Transferable to UC, CSU (CAN ENGL 14)  
Prerequisite: ENGL 52 or ENGL 72 or ESL 152 or equivalent with a grade of "C" or higher or "Pass", or completion of the English assessment/placement process with eligibility for ENGL 100 or ENGL 100S.

23471 1:00- 2:30PM MW Clifford,S REMOTE  
Class# 23471 meets 09/09/2020-12/16/2020

**ENGL 231 - 3.0 UNITS LITERATURE AND FILM**

Transferable to UC, CSU  
Prerequisite: ENGL 52 or ENGL 72 or ESL 152 or equivalent with a grade of "C" or higher or "Pass" or satisfactory completion of the assessment/placement process with eligibility for ENGL 100 or ENGL 100S.

30167 3.0 HRS ARR (OL) STAFF ONLINE

**ENGL 234 - 3.0 UNITS READINGS IN SHORT FICTION**

Transferable to UC, CSU (CAN ENGL 18)  
Prerequisite: ENGL 52 or ENGL 72 or ESL 152 or equivalent with a grade of "C" or higher or "Pass", or completion of the English assessment/placement process with eligibility for ENGL 100 or ENGL 100S.

26963 6.0 HRS ARR (OL) Gonzales,J ONLINE  
Class# 26963 meets 10/19/2020-12/18/2020

**ENGL 237 - 3.0 UNITS ASIAN AMERICAN LITERATURE**

Transferable to UC, CSU  
Prerequisite: ENGL 52 or ENGL 72 or ESL 152 or equivalent with a grade of "C" or higher or "Pass", or completion of the English assessment/placement process with eligibility for ENGL 100 or ENGL 100S.

30169 3.0 HRS ARR (OL) Fagundes,M ONLINE  
MANDATORY ORIENTATION: All enrolled students must complete the online orientation that is located on Canvas to remain enrolled in this course.

**ENGL 240 - 3.0 UNITS CREATIVE WRITING**

Transferable to UC, CSU (CAN ENGL 6)  
Prerequisite: ENGL 52 or ENGL 72 or ESL 152 or equivalent with a grade of "C" or higher, or of "Pass", or completion of the English placement process with eligibility for ENGL 100 or ENGL 100S.

20220 5:00-6:15PM Th Altbarmakian,T REMOTE

**ENGL 241 - 3.0 UNITS SCREENWRITING**

Transferable to UC, CSU  
Prerequisite: ENGL 52 or ENGL 72 or ESL 152 or equivalent with a grade of "C" or higher or "Pass", or completion of the English assessment/placement process with eligibility for ENGL 100 or ENGL 100S.

20692 3.0 HRS ARR (OL) Greene,C ONLINE

**ENGL 244 - 3.0 UNITS WRITING SHORT FICTION**

Transferable to UC, CSU  
Prerequisite: ENGL 240 or equivalent with a grade of 'C' or higher, or 'Pass'.

30168 3.0 HRS ARR (OL) Greene,C ONLINE

**ENGL 246A - 3.0 UNITS SURVEY OF BRITISH LITERATURE A: ANGLO-SAXON TO 18TH CENTURY**

Transferable to UC, CSU (CAN ENGL 8)  
Prerequisite: ENGL 100 or ENGL 100S or equivalent with a grade of "C" or higher, or "Pass", or completion of the English assessment/placement process.

20221 3.6 HRS ARR (OL) Lovejoy-Robold,N ONLINE  
Class# 20221 meets 09/08/2020-12/18/2020

**ENGL 248A - 3.0 UNITS MASTERPIECES OF WORLD LITERATURE**

Transferable to UC, CSU  
Prerequisite: ENGL 52 or ENGL 72 or ESL 152 or equivalent with a grade of "C" or higher or "Pass", or completion of the English assessment/placement process with eligibility for ENGL 100 or ENGL 100S.

20694 3.0 HRS ARR (OL) Greene,C ONLINE

# ENGLISH AS A SECOND LANGUAGE

## CREDIT ESL COURSE SEQUENCE

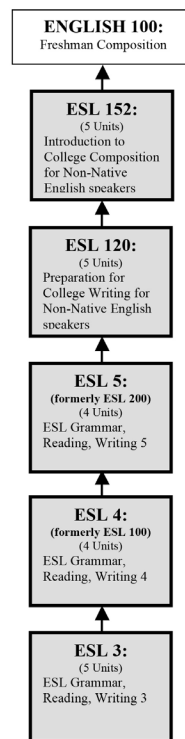

### ESL CORE COURSES

ESL core classes emphasize grammar, reading, and writing. Our core courses prepare non-native English students who plan to get a certificate, AA degree, or take college-level courses. Students need to take the ESL Accuplacer test in the Assessment Center. Placement in a core course is based on the score of the assessment test. The Accuplacer test for native speakers of English may NOT be substituted for placement in ESL core courses.

**ESL 3 - 5.0 UNITS ESL GRAMMAR, READING, AND WRITING 3**

Not Transferable  
22678 9:00-11:50AM MW Sugihara-Cheatham,J REMOTE  
Class# 22678 meets 09/09/2020-12/16/2020

**ESL 4 - 4.0 UNITS ESL GRAMMAR, READING AND WRITING 4**

Not Transferable  
Prerequisite: ESL 3 with a grade of "C" or higher or "Pass" or equivalent or AED 42.17 or equivalent (non-credit Adult Ed. ESL) with a grade of "Pass" or satisfactory completion of the assessment/placement process with eligibility for ESL 4.  
27777 9:00-10:50AM TTh Rouhi,S REMOTE  
+ 1.0 HRS ARR Rouhi,S REMOTE  
LAB IS ONE HOUR PER WEEK  
26023 6:30-8:40PM TTh Rouhi,S REMOTE  
+ 1.2 HRS ARR Rouhi,S REMOTE  
LAB IS 1.2 HOURS PER WEEK I  
Class# 26023 meets 09/09/2020-12/16/2020

**ESL 5 - 4.0 UNITS ESL GRAMMAR, READING, AND WRITING 5**

Not Transferable  
Prerequisite: ESL 4 with a grade of "C" or higher or "Pass" or equivalent or AED 42.18 or equivalent (non-credit Adult Ed. ESL) with a grade of "Pass" or satisfactory completion of the assessment/placement process with eligibility for ESL 5.  
23605 9:00-10:50AM TTh STAFF REMOTE  
+ 1.0 HRS ARR STAFF REMOTE  
LAB IS ONE HOUR PER WEEK

If a class displays as **REMOTE** in the schedule, students will be expected to log into the class at a specified day/time (e.g., MW 8-9:15am). If the class displays as **ONLINE** in the schedule, students are permitted to log into the class whenever they are available to complete coursework by the established deadlines.

Students not in attendance or late for the first class meeting are subject to drop.

Class#	Time	Day	Instructor	Room	Class#	Time	Day	Instructor	Room
29623	4.0 HRS ARR	(OL)	Cox,W	ONLINE	<b>ESL 152 - 5.0 UNITS INTRODUCTION TO COLLEGE COMPOSITION FOR NON-NATIVE ENGLISH S</b>				
30535	1.0 HRS ARR	(OL)	Cox,W	ONLINE	Transferable to UC, CSU				
30648	12:30- 3:20PM + 1.0 HRS ARR	TTh	Sugihara-Cheetham,J Sugihara-Cheetham,J	REMOTE REMOTE	Prerequisite: Completion of the English as a Second Language placement process with a qualifying score for ESL 152 or completion of ESL 120 or equivalent with a grade of Pass or "C" or higher.				
Note: This class is a CCAP Dual Enrollment class for Downey Adult School students.					29822	8:30-10:50AM + 1.0 HRS ARR	MW	Nunez,V Nunez,V	REMOTE REMOTE
<b>ESL 10 - 3.0 UNITS ESL SPEAKING AND LISTENING 1</b>					LAB IS ONE HOUR PER WEEK				
Not Transferable					<b>27913</b>	<b>6:30- 9:20PM</b>	<b>MW</b>	Nunez,V (HYBRID)	REMOTE
30650	3.6 HRS ARR	(OL)	Fischer,A	ONLINE	+ 1.2 HRS ARR				
Class# 30650 meets 09/08/2020-12/18/2020					LAB IS 1.2 HOURS PER WEEK				
26970	12:30- 2:05PM	MW	Sugihara-Cheetham,J	REMOTE	Class# 27913 meets 09/09/2020-12/16/2020				
Class# 26970 meets 09/09/2020-12/16/2020					25488	12:30- 3:20PM + 1.2 HRS ARR	TTh	Jaquibino,E Jaquibino,E	REMOTE
<b>ESL 11 - 1.5 UNITS ESL READING 1</b>					LAB IS 1.2 HOURS PER WEEK				
Not Transferable					Class# 25488 meets 09/08/2020-12/17/2020				
25626	3.0 HRS ARR	(OL)	Berry,P	ONLINE	26973	11:00- 2:20PM + 2.0 HRS ARR	MWF	McIlroy,L (HYBRID) McIlroy,L	REMOTE REMOTE
MANDATORY ORIENTATION: Please see the course syllabus in Canvas for the orientation materials.					LAB IS 2.0 HOURS PER WEEK				
Class# 25626 meets 08/17/2020-10/16/2020					Class# 26973 meets 10/19/2020-12/18/2020				
<b>ESL 12 - 1.5 UNITS ESL PRONUNCIATION</b>									
Not Transferable									
29219	11:00-12:30PM	TTh	Jaquibino,E	REMOTE					
Class# 29219 meets 08/18/2020-10/15/2020									
<b>ESL 14 - 3.0 UNITS PRONUNCIATION PLUS</b>									
Not Transferable									
23479	3.6 HRS ARR	(OL)	Berry,P	ONLINE					
MANDATORY ORIENTATION: Please see the course syllabus in Canvas for the orientation materials.									
Class# 23479 meets 09/08/2020-12/18/2020									
<b>ESL 20 - 3.0 UNITS ESL SPEAKING AND LISTENING 2</b>									
Not Transferable									
Recommendation: ESL 10 or equivalent with a grade of Pass or "C" or higher.									
30651	3.6 HRS ARR	(OL)	Fischer,A	ONLINE					
Class# 30651 meets 09/08/2020-12/18/2020									
<b>ESL 21A - 3.0 UNITS ESL INTERMEDIATE VOCABULARY</b>									
Not Transferable									
30171	3.6 HRS ARR	(OL)	Berry,P	ONLINE					
MANDATORY ORIENTATION: Please see the course syllabus in Canvas for the orientation materials.									
Class# 30171 meets 09/08/2020-12/18/2020									
<b>ESL 31 - 1.5 UNITS ESL READING 2</b>									
Not Transferable									
25629	3.0 HRS ARR	(OL)	Berry,P	ONLINE					
MANDATORY ORIENTATION: Please see the course syllabus in Canvas for the orientation materials.									
Class# 25629 meets 10/19/2020-12/18/2020									
<b>ESL 35 - 1.5 UNITS EDITING ADVANCED GRAMMAR/SYNTAX</b>									
Not Transferable									
29220	11:00-12:30PM + 1.0 HRS ARR	TTh	Rouhi,S Rouhi,S	REMOTE REMOTE					
LAB IS ONE HOUR PER WEEK									
Class# 29220 meets 10/20/2020-12/17/2020									
<b>ESL 120 - 5.0 UNITS PREPARATION FOR COLLEGE WRITING FOR NON-NATIVE ENGLISH SPEAK</b>									
Transferable to UC, CSU									
Prerequisite: Completion of the English as a Second Language placement process with a qualifying score for ESL 120 or completion of ESL 5, ESL 200, or equivalent with a grade of Pass or "C" or higher.									
23697	8:30-10:50AM + 1.0 HRS ARR	TTh	STAFF STAFF	REMOTE REMOTE					
LAB IS ONE HOUR PER WEEK									
29625	12:30-3:20PM + 1.0 HRS ARR	TTh	McIlroy,L McIlroy,L	REMOTE REMOTE					
LAB IS ONE HOUR PER WEEK									
23699	6.0 HRS ARR + 1.2 HRS ARR	(OL)	Stammlier,C Stammlier,C	ONLINE ONLINE					
LAB IS 1.2 HOURS PER WEEK									
Class# 23699 meets 09/08/2020-12/18/2020									
26971	11:00- 2:10PM + 2.0 HRS ARR	MWF	McIlroy,L McIlroy,L	REMOTE REMOTE					
LAB IS 2.0 HOURS PER WEEK									
Class# 26971 meets 08/17/2020-10/16/2020									

## FILM

### FILM 101 - 3.0 UNITS MOTION PICTURE PRODUCTION

Transferable to CSU

NOTE: a material fee of \$40.00 is required for FILM 101

21843	2.0 HRS ARR + 4.0 HRS ARR	(OL)	Turowski,K Turowski,K	ONLINE ONLINE
28218	2.0 HRS ARR + 4.0 HRS ARR	(OL)	Turowski,K Turowski,K	ONLINE ONLINE
29423	2.0 HRS ARR + 4.0 HRS ARR	(OL)	Hirohama,S Hirohama,S	ONLINE ONLINE

### FILM 102 - 3.0 UNITS TELEVISION PRODUCTION

Transferable to CSU

NOTE: a material fee of \$40.00 is required for FILM 102

30316	1.0 HRS ARR + 5.0 HRS ARR	(OL)	Karshmer,A Karshmer,A	ONLINE ONLINE
28238	1.0 HRS ARR + 5.0 HRS ARR	(OL)	Karshmer,A Karshmer,A	ONLINE ONLINE

### FILM 103 - 3.0 UNITS TELEVISION COMMERCIAL AND PUBLIC SERVICE ANNOUNCEMENT PRODUCTION

Transferable to CSU

Prerequisite: FILM 101 or FILM 102 or equivalent with a grade of Pass or "C" or higher

NOTE: a material fee of \$40.00 is required for FILM 103

30318	2.0 HRS ARR + 4.0 HRS ARR	(OL)	Karshmer,A Karshmer,A	ONLINE ONLINE
30320	2.0 HRS ARR + 4.0 HRS ARR	(OL)	Karshmer,A Karshmer,A	ONLINE ONLINE

### FILM 104 - 3.0 UNITS MOTION PICTURE AND DIGITAL CINEMATOGRAPHY

Transferable to CSU

Prerequisite: FILM 101 or equivalent with a grade of Pass or "C" or higher

NOTE: a material fee of \$40.00 is required for FILM 104

29429	2.0 HRS ARR + 4.0 HRS ARR	(OL)	Hirohama,S Hirohama,S	ONLINE ONLINE
30048	2.0 HRS ARR + 4.0 HRS ARR	(OL)	Dowell,A Dowell,A	ONLINE ONLINE
Class# 30048 meets 08/22/2020-12/12/2020				

### FILM 241 - 3.0 UNITS SCREENWRITING

Transferable to UC, CSU

Prerequisite: ENGL 52 or ENGL 72 or ESL 152 or equivalent with a grade of "C" or higher or "Pass" or completion of the English assessment/placement process with eligibility for ENGL 100 or ENGL 100S.

23435	3.6 HRS ARR	(OL)	Campolo,R	ONLINE
Class# 23435 meets 10/19/2020-12/18/2020				

If a class displays as **REMOTE** in the schedule, students will be expected to log into the class at a specified day/time (e.g., MW 8-9:15am). If the class displays as **ONLINE** in the schedule, students are permitted to log into the class whenever they are available to complete coursework by the established deadlines.

Students not in attendance or late for the first class meeting are subject to drop.

Class#	Time	Day	Instructor	Room	Class#	Time	Day	Instructor	Room
<b>FILM 294 - 3.0 UNITS ADVANCED MOTION PICTURE PRODUCTION</b> Transferable to CSU Prerequisite: FILM 101, FILM 104, and FILM 107 or equivalents with a grade of Pass or "C" or higher NOTE: a material fee of \$40.00 is required for FILM 294					<b>FREN 201 - 5.0 UNITS INTERMEDIATE FRENCH</b> Transferable to UC, CSU (CAN FREN 8) Prerequisite: FREN 102 or equivalent with a grade of Pass or "C" or higher.				
29431	2.0 HRS ARR	(OL)	Hirohama,S	ONLINE	20236	11:00- 1:15PM	MW	Florescu,M	REMOTE
	+ 4.0 HRS ARR	(OL)	Hirohama,S	ONLINE				Florescu,M	REMOTE

## FINANCE

<b>FIN 51 - 1.5 UNITS RETIREMENT PLANNING AND INVESTING</b> Not Transferable NOTE: a material fee of \$2.50 is required for FIN 51				
21959	7:00- 9:50PM	T	Wang,C	REMOTE
Note: Class will meet the first day and the instructor will inform the students of future class meetings. Class# 21959 meets 10/20/2020-12/15/2020				
<b>FIN 125 - 3.0 UNITS PERSONAL FINANCE</b> Transferable to CSU NOTE: a material fee of \$4.00 is required for FIN 125				
21957	3.0 HRS ARR	(OL)	Korniakov,A	ONLINE
Note: For class information and orientation, visit the Canvas website				
<b>FIN 125M - 3.0 UNITS PERSONAL FINANCE</b> Transferable to CSU Prerequisite: MATH 60 or equivalent with a grade of "C" or higher or "Pass: or completion of the Math Placement Process with a score eligible for MATH 80 or MATH 80A.				
29587	3.0 HRS ARR	(OL)	Moloney,P	ONLINE
Note: Orientation and all class work are done online. Email instructor at pmoloney@cerritos.edu				
29588	3.0 HRS ARR	(OL)	Moloney,P	ONLINE
Note: Orientation and all class work are done online. Email instructor at pmoloney@cerritos.edu				
30370	3.0 HRS ARR	(OL)	Korniakov,A	ONLINE
Note: For class information and orientation, visit the Canvas website				
30013	3.6 HRS ARR	(OL)	Aeryn,T	ONLINE
Note: For class information and orientation, visit the Canvas website. Class# 30013 meets 09/08/2020-12/18/2020				
30371	3.6 HRS ARR	(OL)	Farina,M	ONLINE
Note: For class information and orientation, visit the Canvas website Class# 30371 meets 09/08/2020-12/18/2020				
<b>FIN 126 - 3.0 UNITS INTRODUCTION TO STOCK MARKET AND INVESTMENTS</b> Transferable to CSU				
21958	7:00- 9:50PM	W	Wang,C	REMOTE

## FRENCH

<b>FREN 101 - 5.0 UNITS ELEMENTARY FRENCH</b> Transferable to UC, CSU (CAN FREN 2)				
20233	12:30- 2:45PM	TTh	Florescu,M	REMOTE
	+ 1.0 HRS ARR		Florescu,M	REMOTE
LAB IS ONE HOUR PER WEEK				
20234	8:30-10:45AM	MW	Florescu,M	REMOTE
	+ 1.0 HRS ARR		Florescu,M	REMOTE
LAB IS ONE HOUR PER WEEK				
B23952	6:00- 8:15PM	TTh	Nicolas,J	REMOTE
	+ 1.0 HRS ARR		Nicolas,J	REMOTE
LAB IS ONE HOUR PER WEEK				
B29223	7:00- 9:15PM	MW	Nicolas,J	REMOTE
	+ 1.0 HRS ARR		Nicolas,J	REMOTE
LAB IS ONE HOUR PER WEEK				
<b>FREN 102 - 5.0 UNITS ELEMENTARY FRENCH</b> Transferable to UC, CSU (CAN FREN 4) Prerequisite: FREN 101 or equivalent with a grade of Pass or "C" or higher.				
20235	8:30-10:45AM	TTh	Florescu,M	REMOTE
	+ 1.0 HRS ARR		Florescu,M	REMOTE
LAB IS ONE HOUR PER WEEK				

<b>FREN 202 - 4.0 UNITS INTERMEDIATE FRENCH</b> Transferable to UC, CSU (CAN FREN 10) Prerequisite: FREN 201 or equivalent with a grade of Pass or "C" or higher.				
20237	11:00-12:50PM	MW	Florescu,M	REMOTE
<b>FREN 203 - 4.0 UNITS INTERMEDIATE FRENCH ADVANCED LEVEL I</b> Transferable to UC, CSU Prerequisite: FREN 202 or equivalent with a grade of Pass or "C" or higher.				
20238	11:00-12:50PM	MW	Florescu,M	REMOTE

## GEOGRAPHY

<b>GEOG 101 - 3.0 UNITS PHYSICAL GEOGRAPHY</b> Transferable to UC, CSU (CAN GEOG 2)				
22791	3.0 HRS ARR	(OL)	Lo Vetere,C	ONLINE
29010	3.0 HRS ARR	(OL)	Conley,J	ONLINE
20239	3.0 HRS ARR	(OL)	Barajas,D	ONLINE
20241	3.0 HRS ARR	(OL)	Lo Vetere,C	ONLINE
26913	3.0 HRS ARR	(OL)	Surfas,L	ONLINE
23823	3.0 HRS ARR	(OL)	Lo Vetere,C	ONLINE
23998	3.0 HRS ARR	(OL)	Lo Vetere,C	ONLINE
29005	3.0 HRS ARR	(OL)	Surfas,L	ONLINE
27055	3.6 HRS ARR	(OL)	Conley,J	ONLINE
Class# 27055 meets 09/08/2020-12/18/2020				
<b>GEOG 101L - 1.0 UNIT PHYSICAL GEOGRAPHY LABORATORY</b> Transferable to UC, CSU Prerequisite: GEOG 101 or equivalent with a grade of "C" or higher or "Pass" or concurrent enrollment.				
21466	3.0 HRS ARR	(OL)	Lo Vetere,C	ONLINE
21467	3.0 HRS ARR	(OL)	Lo Vetere,C	ONLINE
27056	3.0 HRS ARR	(OL)	Lo Vetere,C	ONLINE
<b>GEOG 102 - 3.0 UNITS CULTURAL GEOGRAPHY</b> Transferable to UC, CSU (CAN GEOG 4)				
20242	3.0 HRS ARR	(OL)	Goode,R	ONLINE
23821	6.0 HRS ARR	(OL)	Goode,R	ONLINE
Note: Orientation: All Class information will be available online via Canvas. Email address: rgoode@cerritos.edu Class# 23821 meets 10/19/2020-12/18/2020				
<b>GEOG 103 - 3.0 UNITS ENVIRONMENTAL GEOGRAPHY</b> Transferable to UC, CSU				
27659	3.0 HRS ARR	(OL)	Barajas,D	ONLINE
<b>GEOG 105 - 3.0 UNITS WORLD REGIONAL GEOGRAPHY</b> Transferable to UC, CSU				
23822	3.0 HRS ARR	(OL)	Goode,R	ONLINE
26914	3.0 HRS ARR	(OL)	Goode,R	ONLINE
27658	6.0 HRS ARR	(OL)	Goode,R	ONLINE
Note: Orientation: All Class information will be available online via Canvas. Email address: rgoode@cerritos.edu Class# 27658 meets 08/17/2020-10/16/2020				

If a class displays as **REMOTE** in the schedule, students will be expected to log into the class at a specified day/time (e.g., MW 8-9:15am). If the class displays as **ONLINE** in the schedule, students are permitted to log into the class whenever they are available to complete coursework by the established deadlines.

Students not in attendance or late for the first class meeting are subject to drop.

Class#	Time	Day	Instructor	Room	Class#	Time	Day	Instructor	Room
--------	------	-----	------------	------	--------	------	-----	------------	------

## GEOLOGY

### GEOL 101 - 4.0 UNITS PHYSICAL GEOLOGY

Transferable to UC, CSU (CAN GEOL 2)  
 Prerequisite: ENGL 52 or ENGL 72 or ESL 152 or equivalent with a grade of "C" or higher or "Pass", or completion of the English placement process with a score eligible for ENGL 100 or ENGL 100S.  
 Recommendation: MATH 40 or equivalent with a grade of "C" or higher or "Pass", or completion of the Math assessment/placement process with a score eligible for MATH 60.

20703	3.0 HRS ARR	(OL)	Lacy,T	ONLINE
Note: Targeted for Future Teachers but Open to all Students				
	+ 4.0 HRS ARR	(OL)	Lacy,T	ONLINE
21888	3.0 HRS ARR	(OL)	Lacy,T	ONLINE
	+ 4.0 HRS ARR	(OL)	Lacy,T	ONLINE
27057	3.0 HRS ARR	(OL)	Berekian,B	ONLINE
	+ 4.0 HRS ARR	(OL)	Berekian,B	ONLINE

### GEOL 102 - 3.0 UNITS PHYSICAL GEOLOGY LECTURE

Transferable to UC, CSU  
 Recommendation: ENGL 52 or ENGL 72 or ESL 152 or equivalent with a grade of "C" or higher or "Pass," or completion of the English assessment/placement tests with a score eligible for ENGL 100 or ENGL 100S; and MATH 40 with a grade of "C" or higher or "Pass," or completion of the Math assessment/ placement process with a score eligible for Math 60.

29011	3.0 HRS ARR	(OL)	Sedki,Z	ONLINE
-------	-------------	------	---------	--------

### GEOL 102L - 1.0 UNIT PHYSICAL GEOLOGY LABORATORY

Transferable to UC, CSU  
 Prerequisite: GEOL 102 or equivalent with a grade of "C" or higher or "Pass" or concurrent enrollment.  
 Recommendation: ENGL 52 or ENGL 72 or ESL 152 or equivalent with a grade of "C" or higher or "Pass", or completion of the English assessment/placement process with a score eligible for ENGL 100 or ENGL 100S; and MATH 40 or equivalent with a grade of "C" or higher or "Pass" or completion of the Math assessment/placement process with a score eligible for MATH 60.

29007	3.0 HRS ARR	(OL)	Leeper III,R	ONLINE
-------	-------------	------	--------------	--------

### GEOL 103 - 3.0 UNITS ENVIRONMENTAL GEOLOGY LECTURE

Transferable to UC, CSU  
 Recommendation: ENGL 100 or ENGL 100S or equivalent with a grade of "C" or higher or "Pass" and MATH 40 or equivalent with a grade of "C" or higher or "Pass" or completion of the Math assessment/placement process with a score eligible for MATH 60.

29008	6.0 HRS ARR	(OL)	Berekian,B	ONLINE
This class is intended for Technology students but is open to all students/majors at the College.				
Class# 29008 meets 10/19/2020-12/18/2020				

### GEOL 298 - 1.0 UNIT DIRECTED STUDIES

Transferable to CSU

30327	3.0 HRS ARR		Lo Vetere,C	
30328	3.0 HRS ARR		Lo Vetere,C	

## GERMAN

### GERM 101 - 5.0 UNITS ELEMENTARY GERMAN

Transferable to UC, CSU (CAN GERM 2)

22436	4:30- 6:45PM	MW	Salvilla,J	REMOTE
	+ 1.0 HRS ARR		Salvilla,J	REMOTE
LAB IS ONE HOUR PER WEEK				

### GERM 102 - 5.0 UNITS ELEMENTARY GERMAN

Transferable to UC, CSU (CAN GERM 4)

Prerequisite: GERM 101 or equivalent with a grade of Pass or "C" or higher.

30405	5.0 HRS ARR	(OL)	Smith,D	ONLINE
	+ 1.0 HRS ARR	(OL)	Smith,D	ONLINE
LAB IS ONE HOUR PER WEEK				

## HEALTH EDUCATION

### HED 100 - 3.0 UNITS CONTEMPORARY HEALTH PROBLEMS

Transferable to UC, CSU

20246	3.0 HRS ARR	(OL)	May,R	ONLINE
20856	3.0 HRS ARR	(OL)	Gonzalez,R	ONLINE
20248	11:00-12:15PM	MW	STAFF	REMOTE
20249	3.0 HRS ARR	(OL)	Gonzalez,R	ONLINE
20250	11:00-12:15PM	TTh	Anderson,R	REMOTE
20251	8:00- 9:15AM	TTh	Valencia,B	REMOTE
20254	3.0 HRS ARR	(OL)	Hemmerling,K	ONLINE
20256	2:00- 3:15PM	TTh	STAFF	REMOTE
25071	4:00- 5:15PM	MW	STAFF	REMOTE
20709	9:30-10:45AM	MW	Richardson,C	REMOTE
21626	8:00- 9:15AM	MW	STAFF	REMOTE
21627	3.0 HRS ARR	(OL)	Hemmerling,K	ONLINE
21629	3.0 HRS ARR	(OL)	Hemmerling,K	ONLINE
24492	3.0 HRS ARR	(OL)	STAFF	ONLINE
29659	3.0 HRS ARR	(OL)	May,R	ONLINE
21316	9:00-12:26PM	F	STAFF	REMOTE
Class# 21316 meets 09/11/2020-12/18/2020				
24493	6.0 HRS ARR	(OL)	Murray,K	ONLINE
Class# 24493 meets 08/17/2020-10/16/2020				
20257	6.0 HRS ARR	(OL)	Richardson,C	ONLINE
Class# 20257 meets 08/17/2020-10/16/2020				
25072	6.0 HRS ARR	(OL)	Bueno,N	ONLINE
Class# 25072 meets 08/17/2020-10/16/2020				
20901	6.0 HRS ARR	(OL)	Bueno,N	ONLINE
Class# 20901 meets 10/19/2020-12/18/2020				
21314	6.0 HRS ARR	(OL)	Bueno,N	ONLINE
Class# 21314 meets 10/19/2020-12/18/2020				
27579	6.0 HRS ARR	(OL)	Murray,K	ONLINE
Class# 27579 meets 10/19/2020-12/18/2020				
26741	6.0 HRS ARR	(OL)	STAFF	ONLINE
Class# 26741 meets 10/19/2020-12/18/2020				
28926	6.0 HRS ARR	(OL)	STAFF	ONLINE
Note: Online registered students must go to the Canvas class webpage for mandatory online orientation information.				
Class# 28926 meets 10/19/2020-12/18/2020				
25028	11:00- 1:50PM	TTh	STAFF	REMOTE
Class# 25028 meets 10/20/2020-12/17/2020				

### HED 101 - 3.0 UNITS STRESS MANAGEMENT

Transferable to CSU

29617	6.0 HRS ARR	(OL)	Jensen,D	ONLINE
Note: Online registered students must go to the Canvas class webpage for mandatory online orientation information.				
Class# 29617 meets 08/17/2020-10/16/2020				
29618	6.0 HRS ARR	(OL)	Jensen,D	ONLINE
Note: Online registered students must go to the Canvas class webpage for mandatory online orientation information.				
Class# 29618 meets 08/17/2020-10/16/2020				
29619	6.0 HRS ARR	(OL)	Jensen,D	ONLINE
Note: Online registered students must go to the Canvas class webpage for mandatory online orientation information.				
Class# 29619 meets 08/17/2020-10/16/2020				
30258	6.0 HRS ARR	(OL)	Jensen,D	ONLINE
Class# 30258 meets 08/17/2020-10/16/2020				
29620	6.0 HRS ARR	(OL)	Jensen,D	ONLINE
Note: Online registered students must go to the Canvas class webpage for mandatory online orientation information.				
Class# 29620 meets 10/19/2020-12/18/2020				
30574	6.0 HRS ARR	(OL)	Jensen,D	ONLINE
Class# 30574 meets 10/19/2020-12/18/2020				
30575	6.0 HRS ARR	(OL)	Jensen,D	ONLINE
Class# 30575 meets 10/19/2020-12/18/2020				

### HED 103 - 3.0 UNITS WOMEN, THEIR BODIES AND HEALTH

Transferable to CSU

27089	3.0 HRS ARR		Gusman,E	(Women's Studies) ONLINE
27429	6:30- 9:20PM	TTh	Acosta,P	REMOTE
Class# 27429 meets 10/20/2020-12/17/2020				

If a class displays as **REMOTE** in the schedule, students will be expected to log into the class at a specified day/time (e.g., MW 8-9:15am). If the class displays as **ONLINE** in the schedule, students are permitted to log into the class whenever they are available to complete coursework by the established deadlines.

Students not in attendance or late for the first class meeting are subject to drop.

Class#	Time	Day	Instructor	Room	Class#	Time	Day	Instructor	Room					
<b>HED 105 - 3.0 UNITS MIND, BODY, AND HEALTH</b> Transferable to CSU Prerequisite: Completion of HED 100 or equivalent with a grade of "C" or higher, or "Pass".					30056	11:00-12:50PM	F	STAFF	REMOTE					
29296	6.0 HRS ARR	(OL)	Ramos,B	ONLINE	<b>HO 152 - 3.0 UNITS NORMAL AND THERAPEUTIC NUTRITION</b> Transferable to UC, CSU (CAN FCS 2) Recommendation: A&P 150 and A&P 151 or equivalent with grades of Pass or "C" or higher.									
<b>HED 110 - 3.0 UNITS COMMUNITY FIRST AID AND CPR</b> Transferable to CSU					29281	4:00- 6:50PM	Th	Caminiti,C	REMOTE					
20259	3.0 HRS ARR	(OL)	Anderson,R	ONLINE	<b>HIST 102 - 3.0 UNITS POLITICAL AND SOCIAL HISTORY OF THE UNITED STATES: 1500S TO</b> Transferable to UC, CSU (CAN HIST 8)(CAN HIST SEQ B) Prerequisite: Satisfactory completion of English Placement Process or ENGL 52, ENGL 72, or ESL 152 or equivalent with a grade of Pass or "C" or higher. Recommendation: Satisfactory completion of the Reading Placement Process or READ 54 with a grade of Pass or "C" or higher.									
21213	9:30-10:45AM	MW	Cable,B	REMOTE										
24495	6:00- 8:50PM	T	STAFF	REMOTE										
30259	3.0 HRS ARR	(OL)	Edwards,C	ONLINE	21412	11:00-12:15PM	MW	Haas,J	REMOTE					
<b>HED 200 - 3.0 UNITS NUTRITION FOR HEALTH, FITNESS, AND PHYSICAL ACTIVITY</b> Transferable to UC, CSU					21413	8:00- 9:15AM	MW	Davis,J	REMOTE					
20260	9:30-10:45AM	MW	Bueno,N	REMOTE	21414	9:30-10:45AM	MW	Davis,J	REMOTE					
<b>HED 202 - 3.0 UNITS HEALTH SYSTEMS AND PERSPECTIVES</b> Transferable to CSU Prerequisite: Completion of HED 100 or equivalent with a grade of "C" or higher, or "Pass". Recommendation: Completion of ENGL 100 or ENGL 100S or equivalent with a grade of "C" or higher, or "Pass".					21415	9:30-10:45AM	TTh	Haas,J	REMOTE					
29297	6.0 HRS ARR	(OL)	Bueno,N	ONLINE	Targeted for Future Teachers but Open to all Students									
Note: Online registered students must go to the Canvas class webpage for mandatory online orientation information. Class# 29297 meets 08/17/2020-10/16/2020					21416	3.0 HRS ARR	(OL)	Hall,D	ONLINE					
<b>HEALTH OCCUPATIONS</b>					23780	12:30- 1:45PM	TTh	Waszak,L	REMOTE					
					26223	3.0 HRS ARR	(OL)	Hall,D	ONLINE					
<b>HO 53 - 1.0 UNIT ELECTROCARDIOGRAPHY</b> Not Transferable NOTE: a material fee of \$12.00 is required for HO 53 + 2.0 HRS ARR (OL) Bucho,P ONLINE					23877	3.0 HRS ARR	(OL)	Fernandez,W	ONLINE					
PLEASE ENROLL IN LAB SECTION OF YOUR CHOICE. THE LECTURE SECTION #20944 WILL BE AUTOMATICALLY ADDED. Class# 20944 meets 08/18/2020-09/22/2020					21417	9:00-11:50AM	F	Latson,J	REMOTE					
20944	4:00- 6:50PM	T	Bucho,P	SL105	25990	3.0 HRS ARR	(OL)	Fernandez,W	ONLINE					
20945	4:00- 6:50PM	T	Bucho,P	SL105	26222	3.0 HRS ARR	(OL)	Hall,D	ONLINE					
Class# 20945 meets 08/18/2020-09/22/2020					26224	5:30- 6:45PM	TTh	Qasqas,A	REMOTE					
30553	7:00-9:50PM	T	Bucho,P	SL105	27007	3.0 HRS ARR	(OL)	Swendson,P	ONLINE					
<b>HO 54 - 1.0 UNIT MEDICAL LABORATORY SKILLS</b> Not Transferable NOTE: a material fee of \$19.00 is required for HO 54 + 2.0 HRS ARR (OL) Gurrola,M ONLINE					Note: Online orientation via Canvas for History 102 is to be completed during the first week of class course to confirm enrollment in class.									
PLEASE ENROLL IN LAB SECTION OF YOUR CHOICE. THE LECTURE SECTION #20903 WILL BE AUTOMATICALLY ADDED. Class# 30553 meets 08/18/2020-09/22/2020					27268	3.0 HRS ARR	(OL)	Swendson,P	ONLINE					
20903	4:00- 6:50PM	T	Gurrola,M	SL105	Note: Online orientation via Canvas for History 102 is to be completed during the first week of class course to confirm enrollment in class.									
20904	4:00- 6:50PM	T	Gurrola,M	SL105	27269	3.0 HRS ARR	(OL)	Heeren,J	ONLINE					
Class# 20904 meets 09/29/2020-11/03/2020					27743	3.0 HRS ARR	(OL)	Fernandez,W	ONLINE					
30554	7:00- 9:50PM	T	Gurrola,M	SL105	29727	12:30- 1:45PM	MW	Davis,J	REMOTE					
<b>HO 55 - 1.5 UNITS PHLEBOTOMY PROCEDURES</b> Not Transferable Recommendation: MA 161 or equivalent with a grade of Pass or "C" or higher. NOTE: a material fee of \$29.00 is required for HO 55 + 2.0 HRS ARR (OL) Bucho,P ONLINE					Targeted for Future Teachers but Open to all Students									
PLEASE ENROLL IN LAB SECTION OF YOUR CHOICE. THE LECTURE SECTION #20892 WILL BE AUTOMATICALLY ADDED. Class# 30554 meets 09/29/2020-11/03/2020					30381	3:00- 4:30PM	MW	Read,R	REMOTE					
20892	4:00- 6:50PM	W	Bucho,P	SL105	Note: This class meets at the La Mirada Educational Center, 15310 Alondra Blvd, La Mirada, CA 90638. Class# 30381 meets 09/09/2020-12/16/2020									
20893	4:00- 6:50PM	W	Bucho,P	SL105	26764	4:00- 5:30PM	TTh	Waszak,L	REMOTE					
Class# 20893 meets 08/19/2020-10/14/2020					Class# 26764 meets 09/08/2020-12/17/2020									
30555	7:00-9:50PM	W	Bucho,P	SL105	22143	6.0 HRS ARR	(OL)	Hawkins,M	ONLINE					
Class# 30555 meets 08/19/2020-10/14/2020					Class# 22143 meets 08/17/2020-10/16/2020									
<b>HO 56 - 1.0 UNIT MEDICATION CALCULATIONS</b> Not Transferable Prerequisite: MATH 40 or equivalent with a grade of Pass or "C" or higher or satisfactory completion of the Math Placement Process.					27270	7:00- 9:50PM	MW	Latson,J	REMOTE					
20894	8:00- 9:50AM	W	Makarem,N	REMOTE	Class# 27270 meets 10/19/2020-12/06/2020									
Class# 20894 meets 08/19/2020-10/14/2020					<b>HIST 103 - 3.0 UNITS POLITICAL AND SOCIAL HISTORY OF THE UNITED STATES: 1877 TO P</b> Transferable to UC, CSU (CAN HIST 10)(CAN HIST SEQ B) Prerequisite: Satisfactory completion of English Placement Process or ENGL 52, ENGL 72, or ESL 152 or equivalent with a grade of Pass or "C" or higher. Recommendation: Satisfactory completion of the Reading Placement Process or READ 54 with a grade of Pass or "C" or higher.									
<b>HEALTH OCCUPATIONS</b>					22577	8:00- 9:15AM	TTh	Davis,J	REMOTE					
					21418	3.0 HRS ARR	(OL)	Jarrett,G	ONLINE					
					22578	5:30- 6:45PM	MW	Macias,J	REMOTE					
					Note: Emphasis on the Mexican American/Latino(a) experience.					21419	2:00- 3:15PM	MW	Macias,J	REMOTE
					Note: Emphasis on the Mexican American/Latino(a) experience.					21691	9:30-10:45AM	TTh	Read,R	REMOTE
					21693	3.0 HRS ARR	(OL)	Jarrett,G	ONLINE					
					22884	8:00- 9:15AM	TTh	Haas,J	REMOTE					
					21842	3.0 HRS ARR	(OL)	Heeren,J	ONLINE					
					24022	3.0 HRS ARR	(OL)	Jarrett,G	ONLINE					
					23781	2:00- 3:15PM	TTh	Macias,J	REMOTE					
Note: Emphasis on the Mexican American/Latino(a) experience.														

If a class displays as **REMOTE** in the schedule, students will be expected to log into the class at a specified day/time (e.g., MW 8-9:15am). If the class displays as **ONLINE** in the schedule, students are permitted to log into the class whenever they are available to complete coursework by the established deadlines.

Students not in attendance or late for the first class meeting are subject to drop.

Class#	Time	Day	Instructor	Room	Class#	Time	Day	Instructor	Room
26225	12:30- 1:45PM	MW	Macias,J	REMOTE					
	Note: Emphasis on the Mexican American/Latino(a) experience.								
24460	3.0 HRS ARR	(OL)	Jarrett,G	ONLINE					
27008	3.0 HRS ARR	(OL)	Heeren,J	ONLINE					
	Note: Online orientation via Canvas for History 103 is to be completed during the first week of class course to confirm enrollment in class.								
24461	3.6 HRS ARR	(OL)	Hunt,R	ONLINE					
	Note: Online orientation via Canvas for History 103 is to be completed during the first week of class course to confirm enrollment in class.								
	Class# 24461 meets 09/08/2020-12/18/2020								
24462	3.6 HRS ARR	(OL)	Hunt,R	ONLINE					
	Note: Online orientation via Canvas for History 103 is to be completed during the first week of class course to confirm enrollment in class.								
	Class# 24462 meets 09/08/2020-12/18/2020								
26761	3.6 HRS ARR	(OL)	Mishler,K	ONLINE					
	Targeted for Technology students but open to all students;								
	Note: Online orientation via Canvas for History 103 is to be completed during the first week of class course to confirm enrollment in class.								
	Class# 26761 meets 09/08/2020-12/18/2020								
30382	3:00- 4:30PM	TTh	Chang,J	REMOTE					
	Note: This class meets at the La Mirada Educational Center, 15310 Alondra Blvd, La Mirada, CA 90638.								
	Class# 30382 meets 09/08/2020-12/17/2020								
21839	6.0 HRS ARR	(OL)	Hawkins,M	ONLINE					
	Class# 21839 meets 10/19/2020-12/18/2020								
27457	6.0 HRS ARR	(OL)	Hawkins,M	ONLINE					
	Class# 27457 meets 10/19/2020-12/18/2020								
<b>HIST 110 - 3.0 UNITS AFRICAN/AMERICAN HISTORY</b>									
Transferable to UC, CSU									
Recommendation: Completion of ENGL 52, or ENGL 72, or ESL 152, or equivalent with a grade of "C" or higher or "Pass" or completion of the assessment/placement process with eligibility for ENGL 100 or ENGL 100S, and satisfactory completion of the Reading assessment/placement process or READ 43 or READ 49 with a grade of "C" or higher or "Pass".									
27272	3.6 HRS ARR	(OL)	Melton,J	ONLINE					
	Class# 27272 meets 09/08/2020-12/18/2020								
<b>HIST 120 - 3.0 UNITS HISTORY OF CALIFORNIA</b>									
Transferable to UC, CSU									
Recommendation: Satisfactory completion of the English Placement Process or ENGL 20 or equivalent with a grade of "C" or higher or "Pass" and satisfactory completion of the Reading Placement Process or READ 43 and READ 49 with a grade of "C" or higher or "Pass".									
20267	12:30- 1:45PM	TTh	Macias,J	REMOTE					
<b>HIST 230 - 3.0 UNITS HISTORY OF MEXICO</b>									
Transferable to UC, CSU									
Recommendation: Satisfactory completion of the English Placement Process or ENGL 20 or equivalent with a grade of "C" or higher or "Pass" and satisfactory completion of the Reading Placement Process or READ 43 or READ 49 with a grade of "C" or higher or "Pass".									
20268	3.0 HRS ARR	(OL)	Fernandez,W	ONLINE					
20712	3.0 HRS ARR	(OL)	Fernandez,W	ONLINE					
<b>HIST 235 - 3.0 UNITS HISTORY OF LATIN AMERICA</b>									
Transferable to UC, CSU									
Recommendation: Satisfactory completion of the English Placement Process or ENGL 52 or equivalent with a grade of Pass or "C" or higher and satisfactory completion of the Reading Placement Process or READ 54 with a grade of Pass or "C" or higher.									
20269	3.0 HRS ARR	(OL)	Fernandez,W	ONLINE					
<b>HIST 241 - 3.0 UNITS WESTERN CIVILIZATION</b>									
Transferable to UC, CSU (CAN HIST 2)(CAN HIST SEQ A)									
Prerequisite: ENGL 52 or ENGL 72 or ESL 152 or equivalent with a grade of "C" or higher or "Pass", or completion of the English assessment/placement process with eligibility for ENGL 100 or ENGL 100S.									
Recommendation: Satisfactory completion of the Reading assessment/placement process or READ 54 or equivalent with a grade of "C" or higher or "Pass".									
22285	11:00-12:15PM	TTh	Waszak,L	REMOTE					
<b>HIST 245 - 3.0 UNITS WORLD CIVILIZATION FROM ANTIQUITY TO 1500</b>									
Transferable to UC, CSU									
Recommendation: READ 54 and ENGL 52 or equivalent with grades of Pass or "C" or higher.									
22307	9:30-10:45AM	MW	Haas,J	REMOTE					
	Targeted for Future Teachers but Open to all Students								
22434	5:30- 6:45PM	MW	Haas,J	REMOTE					
	Targeted for Future Teachers but Open to all Students								
<b>HIST 246 - 3.0 UNITS WORLD CIVILIZATION FROM 1500 TO PRESENT</b>									
Transferable to UC, CSU									
Recommendation: READ 54 and ENGL 52 or equivalent with grades of Pass or "C" or higher.									
20270	2:00- 3:15PM	MW	Haas,J	REMOTE					
<b>HIST 260 - 3.0 UNITS SURVEY OF THE HISTORY OF ASIA</b>									
Transferable to UC, CSU									
Recommendation: Satisfactory completion of the English Placement Process or ENGL 20 or equivalent with a grade of "C" or higher or "Pass" and satisfactory completion of the Reading Placement Process or READ 43 or READ 49 with a grade of "C" or higher or "Pass".									
29124	11:00-12:30PM	TTh	Chang,J	REMOTE					
	Class# 29124 meets 09/08/2020-12/17/2020								

## HUMANITIES

### HUM 100 - 3.0 UNITS THE ART OF BEING HUMAN

Transferable to UC, CSU

Recommendation: ENGL 52, ENGL 72 or ESL 152 AND READ 54 or READ 97 or equivalent with grades of Pass or "C" or higher.

30586	6.0 HRS ARR	(OL)	Trager,J	ONLINE					
	Class# 30586 meets 08/17/2020-10/16/2020								
28036	6.0 HRS ARR	(OL)	Trager,J	ONLINE					
	Class# 28036 meets 08/17/2020-10/16/2020								
23421	6.0 HRS ARR	(OL)	Trager,J	ONLINE					
	Class# 23421 meets 10/19/2020-12/18/2020								

## INTERDISCIPLINARY STUDIES

### INST 151 - 3.0 UNITS PRINCIPLES OF RECOVERY AND PSYCHOSOCIAL REHABILITATION

Transferable to CSU

21420	6:30- 9:20PM	T	Costello,C	REMOTE					
30662	3.0 HRS ARR	(OL)	Dupee,J	ONLINE					

### INST 152 - 3.0 UNITS HELPING RELATIONSHIPS

Transferable to CSU

Prerequisite: INST 151 with a grade of Pass or "C" or higher.

29268	6:30- 9:20PM	W	Martins,M	REMOTE					
-------	--------------	---	-----------	--------	--	--	--	--	--

### INST 272 - 3.0 UNITS SPECIAL POPULATIONS

Transferable to CSU

21698	6:30- 9:20PM	Th	Martins,M	REMOTE					
-------	--------------	----	-----------	--------	--	--	--	--	--

## JAPANESE

### JAPN 101 - 5.0 UNITS ELEMENTARY JAPANESE

Transferable to UC, CSU

21299	2:00- 4:15PM	MW	Larsen,T	REMOTE					
	+ 1.0 HRS ARR								
	LAB IS ONE HOUR PER WEEK								
21649	2:00- 4:15PM	TTh	STAFF	REMOTE					
	+ 1.0 HRS ARR								
	LAB IS ONE HOUR PER WEEK								
28009	4:30- 6:45PM	MW	STAFF	REMOTE					
	+ 1.0 HRS ARR								
	LAB IS ONE HOUR PER WEEK								

### JAPN 102 - 5.0 UNITS ELEMENTARY JAPANESE

Transferable to UC, CSU

Prerequisite: JAPN 101 or equivalent with a grade of Pass or "C" or higher.

30178	4:30- 6:45PM	TTh	Larsen,T	REMOTE					
	+ 1.0 HRS ARR								
	LAB IS ONE HOUR PER WEEK								

If a class displays as **REMOTE** in the schedule, students will be expected to log into the class at a specified day/time (e.g., MW 8-9:15am). If the class displays as **ONLINE** in the schedule, students are permitted to log into the class whenever they are available to complete coursework by the established deadlines.

Students not in attendance or late for the first class meeting are subject to drop.



Class#	Time	Day	Instructor	Room	Class#	Time	Day	Instructor	Room
<b>JOURNALISM</b>					28925	6.0 HRS ARR	(OL)	STAFF	ONLINE
<b>JOUR 100 - 3.0 UNITS MASS COMMUNICATIONS AND SOCIETY</b> Transferable to UC, CSU (CAN JOUR 4)					Note: Online registered students must go to the Canvas class webpage for mandatory online orientation information. Class# 28925 meets 10/19/2020-12/18/2020				
20275	3.0 HRS ARR	(OL)	Brown,C	ONLINE	29826	6.0 HRS ARR	(OL)	Lim,J	ONLINE
27034	3.6 HRS ARR	(OL)	Brown,C	ONLINE	Note: Online registered students must go to the Canvas class webpage for mandatory online orientation information. Class# 29826 meets 10/19/2020-12/18/2020				
Class# 27034 meets 08/17/2020-11/27/2020					29827	6.0 HRS ARR	(OL)	Nguyen,L	ONLINE
<b>JOUR 101 - 3.0 UNITS BEGINNING NEWSWRITING AND REPORTING</b> Transferable to UC, CSU (CAN JOUR 2) Prerequisite: ENGL 52 or ENGL 72 or ESL 152 or equivalent with a grade of "C" or higher or "Pass", or completion of the English assessment/placement process with eligibility for ENGL 100 or ENGL 100S.					Note: Online registered students must go to the Canvas class webpage for mandatory online orientation information. Class# 29827 meets 10/19/2020-12/18/2020				
20276	3.0 HRS ARR	(OL)	Brown,C	ONLINE	<b>KIN 102 - 3.0 UNITS INTRODUCTION TO ATHLETIC TRAINING</b>				
Transferable to UC, CSU					Transferable to UC, CSU				
Recommendation: JOUR 101 or JOUR 121 or equivalents with a grade of Pass or "C" or higher.					24641	11:00-12:15PM	TTh	Luna,M	REMOTE
23548	2.0 HRS ARR	(OL)	Brown,C	ONLINE	25951	8:00- 9:15AM	MW	Castro,M	REMOTE
<b>JOUR 107A - 3.0 UNITS COLLEGE NEWSPAPER</b> Transferable to CSU					<b>KIN 104 - 3.0 UNITS FITNESS AND WELLNESS</b>				
Recommendation: JOUR 101 or JOUR 121 or equivalents with a grade of Pass or "C" or higher.					Transferable to UC, CSU				
+ 3.0 HRS ARR (OL) Brown,C ONLINE					NOTE: a material fee of \$5.00 is required for KIN 104				
<b>JOUR 107B - 3.0 UNITS INTERMEDIATE COLLEGE NEWSPAPER</b> Transferable to CSU					24645	2.0 HRS ARR	(OL)	Nguyen,L	ONLINE
Prerequisite: JOUR 107A or equivalent with a grade of Pass or "C" or better.					Note: Online registered students must go to the Canvas class webpage for mandatory online orientation information.				
23550	2.0 HRS ARR	(OL)	Brown,C	ONLINE	24646	1:00- 1:50PM	MW	Wikert Hoag,R	REMOTE
+ 3.0 HRS ARR (OL) Brown,C ONLINE					24647	2.0 HRS ARR	(OL)	Kozlowski,T	ONLINE
<b>JOUR 107C - 3.0 UNITS INTERMEDIATE ADVANCED COLLEGE NEWSPAPER</b> Transferable to CSU					24650	11:00-12:15PM	MW	Edwards,C	REMOTE
Prerequisite: JOUR 107B or equivalent with a grade of Pass or "C" or better.					24651	2:00- 3:15PM	MW	Wikert Hoag,R	REMOTE
23552	2.0 HRS ARR	(OL)	Brown,C	ONLINE	24652	9:30-10:45AM	TTh	Kozlowski,T	REMOTE
+ 3.0 HRS ARR (OL) Brown,C ONLINE					30262	9:30-10:45AM	MW	Kozlowski,T	REMOTE
<b>JOUR 107D - 3.0 UNITS ADVANCED COLLEGE NEWSPAPER</b> Transferable to CSU					<b>30263</b>	<b>6:00- 7:15PM</b>	<b>TTh</b>	Velazquez-Ortega,M	REMOTE
Prerequisite: JOUR 107C or equivalent with a grade of Pass or "C" or better.					<b>KIN 108 - 3.0 UNITS WOMEN IN SPORTS</b>				
23554	2.0 HRS ARR	(OL)	Brown,C	ONLINE	Transferable to CSU				
+ 3.0 HRS ARR (OL) Brown,C ONLINE					27287	3.0 HRS ARR	(OL)	Kozlowski,T	ONLINE
<b>JOUR 107E - 3.0 UNITS ADVANCED COLLEGE NEWSPAPER</b> Transferable to CSU					Note: Online registered students must go to the Canvas class webpage for mandatory online orientation information.				
Prerequisite: JOUR 107C or equivalent with a grade of Pass or "C" or better.					27401	6.0 HRS ARR	(OL)	Kozlowski,T	ONLINE
23554	2.0 HRS ARR	(OL)	Brown,C	ONLINE	Note: Online registered students must go to the Canvas class webpage for mandatory online orientation information. Class# 27401 meets 10/19/2020-12/18/2020				
+ 3.0 HRS ARR (OL) Brown,C ONLINE					<b>KIN 110 - 3.0 UNITS COMMUNITY FIRST AID AND CPR</b>				
Transferable to CSU					Transferable to CSU				
<b>KINESIOLOGY</b>					28172	3.0 HRS ARR	(OL)	Anderson,R	ONLINE
<b>KIN 100 - 3.0 UNITS INTRODUCTION TO KINESIOLOGY</b> Transferable to UC, CSU					28173	3.0 HRS ARR	(OL)	Cable,B	ONLINE
24640	3.0 HRS ARR	(OL)	Macias,S	ONLINE	<b>28174</b>	<b>6:00- 8:50PM</b>	<b>T</b>	STAFF	REMOTE
25558	3.0 HRS ARR	(OL)	Carizzi,M	ONLINE	30264	3.0 HRS ARR	(OL)	Edwards,C	ONLINE
26249	3.0 HRS ARR	(OL)	Gnodle,D	ONLINE	<b>KIN 130 - 3.0 UNITS THEORY OF COACHING</b>				
26250	3.0 HRS ARR	(OL)	Kingsbury,D	ONLINE	Transferable to UC, CSU				
27090	3.0 HRS ARR	(OL)	Edwards,C	ONLINE	28175	3.0 HRS ARR	(OL)	Grosfeld,S	ONLINE
Note: Online registered students must go to the Canvas class webpage for mandatory online orientation information.					<b>KIN 134 - 2.0 UNITS THEORY OF FOOTBALL</b>				
27994	3.0 HRS ARR	(OL)	Edwards,C	ONLINE	Transferable to UC, CSU				
Note: Online registered students must go to the Canvas class webpage for mandatory online orientation information.					24660	4.0 HRS ARR	(OL)	Grosfeld,S	ONLINE
29621	3.0 HRS ARR	(OL)	Bueno,N	ONLINE	Class# 24660 meets 08/17/2020-10/16/2020				
30261	3:00- 4:40PM	MW	STAFF	REMOTE	24661	4.0 HRS ARR	(OL)	Caines,T	ONLINE
Class# 30261 meets 09/09/2020-12/16/2020					Class# 24661 meets 10/19/2020-12/18/2020				
30260	3.6 HRS ARR	(OL)	Carizzi,M	ONLINE	<b>KIN 202 - 3.0 UNITS MEASUREMENT AND INTERPRETATION OF FITNESS</b>				
Class# 30260 meets 09/08/2020-12/17/2020					Transferable to CSU				
26743	6.0 HRS ARR	(OL)	Kingsbury,M	ONLINE	24663	2.5 HRS ARR	(OL)	Celis,J	ONLINE
Class# 26743 meets 10/19/2020-12/18/2020					+ 2.0 HRS ARR (OL) Celis,J ONLINE				
27995	6.0 HRS ARR	(OL)	Edwards,C	ONLINE	<b>KIN 205 - 3.0 UNITS ANATOMICAL MOVEMENT ANALYSIS</b>				
Note: Online registered students must go to the Canvas class webpage for mandatory online orientation information.					Transferable to UC, CSU				
Class# 27995 meets 10/19/2020-12/18/2020					28169	3.0 HRS ARR	(OL)	Celis,J	ONLINE
28511	6.0 HRS ARR	(OL)	Edwards,C	ONLINE	<b>KIN 206A - 2.0 UNITS LOWER EXTREMITY INJURY ASSESSMENT AND RECONDITIONING</b>				
Note: Online registered students must go to the Canvas class webpage for mandatory online orientation information.					Transferable to UC, CSU				
Class# 28511 meets 10/19/2020-12/18/2020					28170	9:00- 9:30AM	TTh	Luna,M	REMOTE
					9:30-10:50AM TTh Luna,M REMOTE				

If a class displays as **REMOTE** in the schedule, students will be expected to log into the class at a specified day/time (e.g., MW 8-9:15am). If the class displays as **ONLINE** in the schedule, students are permitted to log into the class whenever they are available to complete coursework by the established deadlines.

Students not in attendance or late for the first class meeting are subject to drop.

Class#	Time	Day	Instructor	Room	Class#	Time	Day	Instructor	Room
<b>KIN 211 - 3.0 UNITS SPORT MANAGEMENT</b>					<b>LAW 104 - 3.0 UNITS ADVANCED LEGAL RESEARCH</b>				
Transferable to CSU					Transferable to CSU				
30576	3.0 HRS ARR	(OL)	Gonzalez,R	ONLINE	Prerequisite: LAW 103 or equivalent with a grade of "C" or higher or "Pass".				
27711	3.6 HRS ARR	(OL)	Gusman,E	ONLINE	Recommendation: LAW 56 or equivalent with a grade of "C" or higher or "Pass".				
Class# 27711 meets 09/08/2020-12/18/2020					<b>26203</b>	<b>7:00- 9:50PM</b>	<b>F</b>	Maline,R	REMOTE
29631	6.0 HRS ARR	(OL)	Gonzalez,R	ONLINE	<b>LAW 105 - 3.0 UNITS INTRODUCTION TO FEDERAL AND CALIFORNIA EMPLOYMENT AND LABOR</b>				
Note: Online registered students must go to the Canvas class webpage for mandatory online orientation information.					Transferable to CSU				
Class# 29631 meets 10/19/2020-12/18/2020					<b>24432</b>	<b>7:00- 9:50PM</b>	<b>W</b>	Tchulluian,L	REMOTE
<b>KIN 271A - 1.0 UNIT OCCUPATIONAL WORK EXPERIENCE ATHLETIC TRAINING</b>					<b>LAW 107 - 3.0 UNITS PROBATE PROCEDURES</b>				
Transferable to CSU					Transferable to CSU				
24665	1.0 HRS ARR	(OL)	STAFF	REMOTE	Recommendation: LAW 56 with a grade of "C" or higher or "Pass. NOTE: a material fee of \$4.00 is required for LAW 107				
<b>KIN 271B - 1.0 UNIT OCCUPATIONAL WORK EXPERIENCE IN FITNESS</b>					<b>27005</b>	<b>5:30- 6:45PM</b>	<b>MW</b>	Binning,M	REMOTE
Transferable to CSU					<b>LAW 108 - 3.0 UNITS FAMILY LAW PROCEDURES</b>				
24666	1.0 HRS ARR		STAFF	REMOTE	Transferable to CSU				
<b>KIN 298 - 1.0 UNIT DIRECTED STUDIES</b>					Recommendation: LAW 56 with a grade of "C" or higher or "Pass.				
Transferable to CSU					<b>23783</b>	<b>7:00- 9:50PM</b>	<b>W</b>	Filer,A	REMOTE
28177	1.2 HRS ARR		Grosfeld,S	REMOTE	<b>LAW 109 - 3.0 UNITS TORTS AND PERSONAL INJURY</b>				
Class# 28177 meets 08/17/2020-11/27/2020					Transferable to CSU				
28176	2.0 HRS ARR		Grosfeld,S	REMOTE	<b>22876</b>	<b>7:00- 9:50PM</b>	<b>M</b>	Maline,R	REMOTE
Class# 28176 meets 10/19/2020-12/18/2020					<b>LAW 110 - 3.0 UNITS BUSINESS LAW</b>				
<b>KIN 299 - 2.0 UNITS DIRECTED STUDIES</b>					Transferable to UC, CSU				
Transferable to CSU					25412	3.0 HRS ARR	(OL)	Binning,M	ONLINE
28178	1.0 HRS ARR		Grosfeld,S	REMOTE	Orientation: All class information will be available online				
					27982	3.6 HRS ARR	(OL)	Kim,R	ONLINE
					Class# 27982 meets 09/08/2020-12/18/2020				
					<b>LAW 111 - 3.0 UNITS BUSINESS LAW</b>				
					Transferable to UC, CSU (CAN BUS 8)				
					21984	12:30- 1:45PM	MW	Noyes,N	REMOTE
					26748	3.0 HRS ARR	(OL)	Noyes,N	ONLINE
					Orientation: All class information will be available online				
					<b>21986</b>	<b>6:30- 9:50PM</b>	<b>Th</b>	Brown Jr.,W	REMOTE
					Class# 21986 meets 09/10/2020-12/17/2020				
					<b>LAW 113 - 3.0 UNITS FUNDAMENTALS OF ALTERNATE DISPUTE RESOLUTIONS</b>				
					Transferable to CSU				
					Recommendation: LAW 56 with a grade of "C" or higher or "Pass.				
					21989	2:30- 5:20PM	W	Tchulluian,L	REMOTE
					<b>LAW 120 - 3.0 UNITS LEGAL ETHICS</b>				
					Transferable to CSU				
					25411	12:30- 1:45PM	TTh	Sauber,D	REMOTE
					<b>LAW 171 - 1.0 UNIT LEGAL OCCUPATIONAL WORK EXPERIENCE</b>				
					Transferable to CSU				
					<b>21992</b>	<b>6:00- 6:50PM</b>	<b>W</b>	Greenberg,B	REMOTE
					21998	1:00- 1:50PM	W	Greenberg,B	REMOTE
					<b>LAW 172 - 2.0 UNITS LEGAL OCCUPATIONAL WORK EXPERIENCE</b>				
					Transferable to CSU				
					<b>21993</b>	<b>6:00- 6:50PM</b>	<b>W</b>	Greenberg,B	REMOTE
					21999	1:00- 1:50PM	W	Greenberg,B	REMOTE
					<b>LAW 173 - 3.0 UNITS LEGAL OCCUPATIONAL WORK EXPERIENCE</b>				
					Transferable to CSU				
					<b>21994</b>	<b>6:00- 6:50PM</b>	<b>W</b>	Greenberg,B	REMOTE
					22000	1:00- 1:50PM	W	Greenberg,B	REMOTE
					<b>LAW 174 - 4.0 UNITS LEGAL OCCUPATIONAL WORK EXPERIENCE</b>				
					Transferable to CSU				
					<b>21995</b>	<b>6:00- 6:50PM</b>	<b>W</b>	Greenberg,B	REMOTE
					22001	1:00- 1:50PM	W	Greenberg,B	REMOTE
					<b>LAW 230 - 3.0 UNITS CORPORATE LAW</b>				
					Transferable to CSU				
					Recommendation: LAW 56 with a grade of "C" or higher or "Pass.				
					<b>24434</b>	<b>7:00- 9:50PM</b>	<b>W</b>	Binning,M	REMOTE

## LAW

### LAW 56 - 3.0 UNITS INTRODUCTION TO COMPUTERIZED LEGAL SOFTWARE

Not Transferable

21973	9:30-10:45AM	MW	Noyes,N	REMOTE
<b>21974</b>	<b>7:00- 9:50PM</b>	<b>F</b>	Noyes,N	REMOTE

### LAW 65 - 3.0 UNITS ADVANCED LEGAL TECHNOLOGY

Not Transferable

Recommendation: LAW 56 or equivalent with a grade of "C" or higher or "Pass.

<b>27004</b>	<b>7:00- 9:50PM</b>	<b>Th</b>	Binning,M	REMOTE
--------------	---------------------	-----------	-----------	--------

### LAW 100 - 3.0 UNITS INTRODUCTION TO CALIFORNIA CIVIL PROCEDURES

Transferable to CSU

Recommendation: LAW 56 with a grade of "C" or higher or "Pass.

21975	8:00- 9:15AM	TTh	Greenberg,B	REMOTE
<b>21976</b>	<b>7:00- 9:50PM</b>	<b>M</b>	Binning,M	REMOTE

### LAW 101 - 3.0 UNITS INTRODUCTION TO LAW

Transferable to CSU

21977	11:00-12:15PM	TTh	Sauber,D	REMOTE
<b>21996</b>	<b>7:00- 9:50PM</b>	<b>M</b>	Filer,A	REMOTE
23782	11:00-12:15PM	MW	Binning,M	REMOTE
29721	3.0 HRS ARR	(OL)	Sanchez,D	ONLINE

This is a College and Career Access Pathway (CCAP) class targeted for high school students.

### LAW 102 - 3.0 UNITS ADVANCED CALIFORNIA CIVIL PROCEDURES

Transferable to CSU

Prerequisite: LAW 100 with a grade of Pass or "C" or higher.

Recommendation: LAW 56 with a grade of "C" or higher or "Pass.

<b>21979</b>	<b>7:00- 9:50PM</b>	<b>T</b>	Noyes,N	REMOTE
30039	11:00-12:15PM	MW	Noyes,N	REMOTE

### LAW 103 - 3.0 UNITS LEGAL RESEARCH

Transferable to CSU

Recommendation: LAW 101 and LAW 56 or equivalent with grades of Pass or "C" or higher.

21980	9:30-10:45AM	TTh	Greenberg,B	REMOTE
<b>21981</b>	<b>6:00- 8:50PM</b>	<b>T</b>	Greenberg,B	REMOTE

If a class displays as **REMOTE** in the schedule, students will be expected to log into the class at a specified day/time (e.g., MW 8-9:15am). If the class displays as **ONLINE** in the schedule, students are permitted to log into the class whenever they are available to complete coursework by the established deadlines.

Students not in attendance or late for the first class meeting are subject to drop.

Class#	Time	Day	Instructor	Room	Class#	Time	Day	Instructor	Room
<b>LAW 260 - 3.0 UNITS IMMIGRATION LAW</b> Transferable to CSU Recommendation: LAW 56 with a grade of "C" or higher or "Pass." <b>25740 7:00- 9:50PM T</b> Torices,E REMOTE					<b>MTT 92L - 1.0 UNIT MASTERCAM LABORATORY</b> Not Transferable Prerequisite: MTT 51 or MTT 57 or equivalent with a grade of Pass or "C" or higher or appropriate work experience. NOTE: a material fee of \$10.00 is required for MTT 92L <b>22099 3.0 HRS ARR (OL)</b> Barnes,J ONLINE				
<b>LAW 290 - 1.0 UNIT CAPSTONE COURSE-PARALEGAL PROGRAM</b> Transferable to CSU Recommendation: To be taken in the final semester of course work for certificate students, and to be taken in the final semester prior to graduation for Paralegal A. <b>22202 1.0 HRS ARR (OL)</b> Kim,R ONLINE					<b>MTT 96L - 1.0 UNIT CNC MULTI-AXIS MILL MACHINING LAB</b> Not Transferable Prerequisite: MTT 52 or equivalent with a grade of "C" or higher, or "Pass." Corequisite: MTT 71 or equivalent or prior completion, with a grade of "C" or higher, or "Pass." NOTE: a material fee of \$15.00 is required for MTT 96L <b>27123 5:30- 8:20PM W</b> Vo,C ME 3H The lab portion of this class will be a hybrid - partially on campus & partially online. The class will be divided into two groups. Each group will be on campus partially. You will be contacted by your instructor on which group you will be assigned to.				

## LIBRARY

<b>LIBR 100 - 1.0 UNIT INTRODUCTION TO LIBRARY RESEARCH</b> Transferable to UC, CSU <b>22163 2.0 HRS ARR (OL)</b> Schenk,L ONLINE + 2.0 HRS ARR (OL) Schenk,L ONLINE Class# 22163 meets 10/19/2020-12/18/2020 <b>22170 2.0 HRS ARR (OL)</b> Taibjee,S ONLINE + 2.0 HRS ARR (OL) Taibjee,S ONLINE Class# 22170 meets 10/19/2020-12/18/2020				
--	--	--	--	--

## MACHINE TOOL TECHNOLOGY

<b>MTT 51 - 3.5 UNITS MASTERCAM MILLING</b> Not Transferable NOTE: a material fee of \$10.00 is required for MTT 51 Please read the technical standards relevant to this department at <a href="http://cms.cerritos.edu/technology/standards.htm">http://cms.cerritos.edu/technology/standards.htm</a> <b>21725 3.0 HRS ARR (OL)</b> Barnes,J ONLINE + 1.5 HRS ARR (OL) Barnes,J ONLINE				
<b>MTT 52 - 2.5 UNITS SETUP AND OPERATION OF CNC MILLING MACHINES</b> Not Transferable NOTE: a material fee of \$15.00 is required for MTT 52 <b>20756 2.0 HRS ARR (OL)</b> Vo,C ONLINE <b>5:30- 6:50PM F</b> Vo,C ME 3H The lab portion of this class will be a hybrid - partially on campus & partially online. The class will be divided into two groups. Each group will be on campus partially. You will be contacted by your instructor on which group you will be assigned to.				
<b>MTT 56 - 2.0 UNITS CNC SHOP INSPECTION</b> Not Transferable <b>25533 4.0 HRS ARR (OL)</b> Real,Y ONLINE Class# 25533 meets 08/17/2020-10/16/2020				
<b>MTT 57 - 2.5 UNITS SETUP AND OPERATION OF CNC LATHES</b> Not Transferable NOTE: a material fee of \$15.00 is required for MTT 57 <b>21258 2.0 HRS ARR (OL)</b> Vo,C ONLINE <b>5:30- 6:50PM M</b> Vo,C ME 3H The lab portion of this class will be a hybrid - partially on campus & partially online. The class will be divided into two groups. Each group will be on campus partially. You will be contacted by your instructor on which group you will be assigned to.				
<b>MTT 68 - 2.0 UNITS COMPUTER-ASSISTED INSPECTION USING VERISURF</b> Not Transferable <b>23600 4.0 HRS ARR (OL)</b> Husted,C ONLINE Class# 23600 meets 08/17/2020-10/16/2020				
<b>MTT 71 - 2.0 UNITS MASTERCAM MULTI-AXIS MILLING</b> Not Transferable Prerequisite: MTT 51 or equivalent with a grade of "C" or higher or "Pass." <b>26145 2.0 HRS ARR (OL)</b> Vo,C ONLINE				
<b>MTT 72 - 2.0 UNITS MASTERCAM MULTI-AXIS TURNING</b> Not Transferable Prerequisite: MTT 51 or MTT 59 or equivalent with a grade of "C" or higher or "Pass." <b>27620 2.0 HRS ARR (OL)</b> Vo,C ONLINE				

<b>MTT 97L - 1.0 UNIT CNC MULTI-AXIS TURNING LABORATORY</b> Not Transferable Prerequisite: MTT 57 or equivalent with a grade of "C" or higher or "Pass." and Corequisite of MTT 72 or equivalent or prior completion with a grade of "C" or higher or "Pass." NOTE: a material fee of \$15.00 is required for MTT 97L <b>28021 5:30- 8:20PM Th</b> Vo,C ME 3H The lab portion of this class will be a hybrid - partially on campus & partially online. The class will be divided into two groups. Each group will be on campus partially. You will be contacted by your instructor on which group you will be assigned to.				
<b>MTT 100 - 2.0 UNITS MACHINE TOOL INTRODUCTION</b> Transferable to CSU NOTE: a material fee of \$15.00 is required for MTT 100 <b>22386 1.0 HRS ARR (OL)</b> Vo,C ONLINE <b>5:30- 8:20PM T</b> Vo,C ME 2J The lab portion of this class will be a hybrid - partially on campus & partially online. The class will be divided into two groups. Each group will be on campus partially. You will be contacted by your instructor on which group you will be assigned to.				
<b>MTT 110 - 2.0 UNITS INDUSTRIAL MAINTENANCE OF MACHINE TOOLS</b> Transferable to CSU <b>30610 4.0 HRS ARR (OL)</b> Real,Y ONLINE Class# 30610 meets 10/19/2020-12/18/2020				
<b>MTT 168 - 1.0 UNIT ADVANCED COMPUTER-ASSISTED INSPECTION USING VERISURF</b> Transferable to CSU Prerequisite: MTT 68 or equivalent with a grade of "C" or higher or "Pass." Recommendation: ENGT 117 and MTT 56. <b>29261 2.6 HRS ARR (OL)</b> Husted,C ONLINE <b>+ 2.6 HRS ARR (OL)</b> Husted,C ONLINE Class# 29261 meets 10/24/2020-12/05/2020				

If a class displays as **REMOTE** in the schedule, students will be expected to log into the class at a specified day/time (e.g., MW 8-9:15am). If the class displays as **ONLINE** in the schedule, students are permitted to log into the class whenever they are available to complete coursework by the established deadlines.

Students not in attendance or late for the first class meeting are subject to drop.

## MATHEMATICS

### Mathematics Department Sequence of Courses

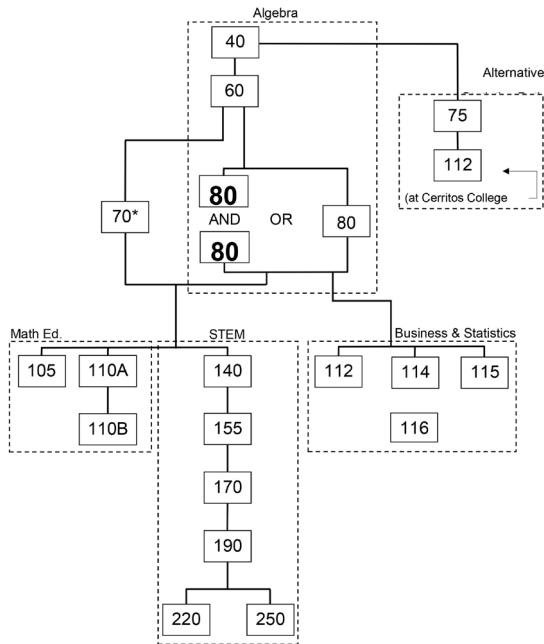

\*Although MATH 70 is not a prerequisite for MATH 115 or MATH 116, it is recommended.

### MATH 5 - 1.0 UNIT MATHEMATICS LEARNING STRATEGIES

Not Transferable

29017	1.0 HRS ARR	(OL)	Mariani,I	ONLINE
Targeted for Future Teachers but Open to all Students				
Note: Students enrolled in this course must also enroll in MATH 114, #20342				
29018	12:00-12:50PM	W	El Abyad,A	REMOTE
Note: Students enrolled in this course must also enroll in MATH 114, #20341				
29019	1.0 HRS ARR	(OL)	Campeau,L	ONLINE
Note: Students enrolled in this course must also enroll in MATH 114, #20741				
<b>29020</b>	<b>5:00- 5:50PM</b>	<b>W</b>	Roque,T	REMOTE
Note: Students enrolled in this course must also enroll in MATH 114, #20740				
29021	10:00-10:50AM	T	Hugen,M	REMOTE
Note: Students enrolled in this course must also enroll in MATH 114, #22806				
29022	10:00-10:50AM	Th	Nguimdjou,E	REMOTE
Note: Students enrolled in this course must also enroll in MATH 114, #26016				
29024	1.0 HRS ARR	(OL)	Pallwitz,K	ONLINE
Note: Students enrolled in this course must also enroll in MATH 114, #29023				
29026	3:00- 3:50PM	T	Hugen,M	REMOTE
Note: Students enrolled in this course must also enroll in MATH 114, #29025				
29027	2:00- 2:50PM	M	Cortez,D	REMOTE
29028	1.0 HRS ARR	(OL)	O'Neil,S	ONLINE
Note: Students enrolled in this course must also enroll in MATH 112, #21301.				
29045	1.0 HRS ARR	(OL)	Morales,M	ONLINE
This MATH 5 class is part of the Health Occupations House in the First Year Experience Program, which includes COUN 200 (#22518), ENGL 100 (#27865), MATH 112 (#20339), and SOC 101 (#20550). To learn more about FYE and to enroll in this house, please visit <a href="https://www.cerritos.edu/lcp/fye.htm">https://www.cerritos.edu/lcp/fye.htm</a> .				
Note: Students enrolled in this course must also enroll in MATH 112, #20339				
29046	1.0 HRS ARR	(OL)	O'Neil,S	ONLINE
Note: Students enrolled in this course must also enroll in MATH 112, #26199.				
29047	1.0 HRS ARR	(OL)	Nikdel,M	ONLINE
Note: Students enrolled in this course must also enroll in MATH 112, #28157				
<b>30627</b>	<b>9:00-9:50PM</b>	<b>W</b>	Can,M	REMOTE
Note: Students enrolled in this course must also enroll in MATH 140, #29404				
29049	2:00- 2:50PM	M	Conley,A	REMOTE
Note: Students enrolled in this course must also enroll in MATH 112, #29040				

<b>30628</b>	<b>5:30-6:20PM</b>	<b>Th</b>	Can,M	REMOTE
Note: Students enrolled in this course must also enroll in MATH 140, #30330				
<b>29051</b>	<b>9:00- 9:50PM</b>	<b>M</b>	Diaz,C	REMOTE
Note: Students enrolled in this course must also enroll in MATH 112, #29042				
29052	1:30- 2:20PM	T	Sarvi,K	REMOTE
Note: Students enrolled in this course must also enroll in MATH 112, #29043				
29053	1.0 HRS ARR	(OL)	Valentine,M	ONLINE
Note: Students enrolled in this course must also enroll in MATH 112, #29044				
29054	10:00-10:50AM	T	Flores,W	REMOTE
29055	1.0 HRS ARR	(OL)	Budarin,D	ONLINE
Note: Students enrolled in this course must also enroll in MATH 112, #27342				
29056	1.0 HRS ARR	(OL)	O'Neil,S	ONLINE
Note: Students enrolled in this course must also enroll in MATH 112, #27341.				
29057	1.0 HRS ARR	(OL)	Bateman,M	ONLINE
Note: Students enrolled in this course must also enroll in MATH 112, #24344				
29058	1.0 HRS ARR	(OL)	Tran,L	ONLINE
Note: Students enrolled in this course must also enroll in MATH 112, #20338				
29059	1.0 HRS ARR	(OL)	Aguilar Bastida,R	ONLINE
Note: Students enrolled in this course must also enroll in MATH 112, #26919.				
29060	1.0 HRS ARR	(OL)	Morales,M	ONLINE
This MATH 5 class is part of the Arts, Humanities, & Communication House in the First Year Experience Program, which includes COUN 200 (#30497), ENGL 100 (#26510), and MATH 112 (#24343). To learn more about FYE and to enroll in this house, please visit <a href="https://www.cerritos.edu/lcp/fye.htm">https://www.cerritos.edu/lcp/fye.htm</a> .				
Note: Students enrolled in this course must also enroll in MATH 112, #24343				
29061	1.0 HRS ARR	(OL)	Budarin,D	ONLINE
Note: Students enrolled in this course must also enroll in MATH 114, #30332				
<b>29062</b>	<b>7:30- 8:20PM</b>	<b>M</b>	Conley,A	REMOTE
Note: Students enrolled in this course must also enroll in MATH 112, #27670				
29063	1:00- 1:50PM	T	Flores,W	REMOTE
Note: Students enrolled in this course must also enroll in MATH 112, #20340				
29064	4:00- 4:50PM	T	Flores,W	REMOTE
Note: Students enrolled in this course must also enroll in MATH 112, #26917				
<b>29065</b>	<b>7:00- 7:50PM</b>	<b>T</b>	Yi,P	REMOTE
Note: Students enrolled in this course must also enroll in MATH 112, #21461				
30629	3:00- 3:50PM	M	Daigle,M	REMOTE
Note: Students enrolled in this course must also enroll in MATH 140, #30335				

### MATH 40 - 4.0 UNITS PREALGEBRA

Not Transferable

Prerequisite: MATH 20 or equivalent with a grade of "C" or higher or "Pass" or completion of the math placement process with a score eligible for MATH 40.

20281	9:00-10:50AM	TTh	Cortez,D	REMOTE
20282	4.0 HRS ARR	(OL)	Campeau,L	ONLINE
*(SEMI-INDEP SECT - LC209)				
20284	4.0 HRS ARR	(OL)	Campeau,L	ONLINE
*(SEMI-INDEP SECT - LC209)				
20290	4.0 HRS ARR	(OL)	Worrel,D	ONLINE
*(SEMI-INDEP SECT - LC209)				
20721	4.0 HRS ARR	(OL)	Worrel,D	ONLINE
*(SEMI-INDEP SECT - LC209)				
20724	4.0 HRS ARR	(OL)	Campeau,L	ONLINE
*(SEMI-INDEP SECT - LC209)				

### MATH 60 - 4.0 UNITS ELEMENTARY ALGEBRA

Not Transferable

Prerequisite: MATH 40 or equivalent with a grade of "C" or higher or "Pass" or completion of the math placement process with a score eligible for MATH 60.

Recommendation: Meet the prerequisite within two years prior to the date of enrollment in MATH 60.

20294	4.0 HRS ARR	(OL)	Campeau,L	ONLINE
*(SEMI-INDEP SECT - LC209)				
20303	4.0 HRS ARR	(OL)	Worrel,D	ONLINE
*(SEMI-INDEP SECT - LC209)				
20726	4.0 HRS ARR	(OL)	Worrel,D	ONLINE
*(SEMI-INDEP SECT - LC209)				
20729	4.0 HRS ARR	(OL)	Campeau,L	ONLINE
*(SEMI-INDEP SECT - LC209)				
21273	4.0 HRS ARR	(OL)	Worrel,D	ONLINE
*(SEMI-INDEP SECT - LC209)				
22257	4.0 HRS ARR	(OL)	Cortez,D	ONLINE
Targeted for Future Teachers but Open to all Students				
26200	4.0 HRS ARR	(OL)	Campeau,L	ONLINE
*(SEMI-INDEP SECT - LC209)				
29408	4.0 HRS ARR	(OL)	Trinh,T	ONLINE
30342	4.8 HRS ARR	(OL)	Tran,L	ONLINE

Class# 30342 meets 08/17/2020-11/27/2020

If a class displays as **REMOTE** in the schedule, students will be expected to log into the class at a specified day/time (e.g., MW 8-9:15am). If the class displays as **ONLINE** in the schedule, students are permitted to log into the class whenever they are available to complete coursework by the established deadlines.

Students not in attendance or late for the first class meeting are subject to drop.

Class#	Time	Day	Instructor	Room	Class#	Time	Day	Instructor	Room
<b>28503</b>	<b>7:00- 9:15PM</b>	<b>MW</b>	Takeuchi,K	REMOTE	20733	4.0 HRS ARR (OL)		Campeau,L	ONLINE
	Class# 28503 meets 09/09/2020-12/16/2020								
<b>23812</b>	<b>5:00- 7:10PM</b>	<b>TTh</b>	Roque,T	REMOTE	22843	4.0 HRS ARR (OL)		Byun,E	ONLINE
	Class# 23812 meets 09/08/2020-12/17/2020								
29726	7:55- 8:50AM	MTWThF	STAFF	REMOTE	<b>26792</b>	<b>8:00- 9:50PM</b>	<b>MW</b>	Ojose,E	REMOTE
	Class# 29726 meets 08/17/2020-12/18/2020								
20295	8.0 HRS ARR (OL)		Beyene,A	ONLINE	24341	4.0 HRS ARR (OL)		Cortez,D	ONLINE
	Class# 20295 meets 08/17/2020-10/15/2020								
<b>MATH 70 - 4.0 UNITS PLANE GEOMETRY</b>									
Not Transferable									
Prerequisite: MATH 60 or equivalent with a grade of "C" or higher or "Pass" or completion of the math placement process with a score eligible for MATH 70.									
20307	4.0 HRS ARR (OL)		Lewandowski,T	ONLINE	25052	4.0 HRS ARR (OL)		Calisher,J	ONLINE
20308	4.0 HRS ARR (OL)		Nikdel,M	ONLINE	27340	4.0 HRS ARR (OL)		Byun,E	ONLINE
<b>20730</b>	<b>7:30- 9:40PM</b>	<b>MW</b>	Bonakdar,M	REMOTE	28231	4.0 HRS ARR (OL)		Trinh,T	ONLINE
	Class# 20730 meets 09/09/2020-12/16/2020								
<b>MATH 75 - 6.0 UNITS MATHEMATICAL LITERACY FOR COLLEGE STUDENTS</b>									
Not Transferable									
Prerequisite: MATH 40 or equivalent with a grade of "C" or higher or "Pass" or completion of the math placement process with a score eligible for MATH 60.									
Recommendation: MATH 40 with a grade of "C" or higher or "Pass" within two years prior to enrollment in MATH 75.									
26920	6.0 HRS ARR (OL)		Johnson,J	ONLINE	29366	4.0 HRS ARR (OL)		Lewandowski,P	ONLINE
26921	8:00- 9:50AM	MWF	Lai,K	REMOTE	29709	9:00-10:50AM	TTh	Cho,A	REMOTE
27666	10:00-11:50AM	TThF	Ngo,H	REMOTE	30341	4.8 HRS ARR (OL)		Torres,M	ONLINE
29035	6.0 HRS ARR (OL)		Ford,D	ONLINE	Class# 30341 meets 08/17/2020-11/27/2020				
29036	1:30- 4:20PM	TTh	Diaz,C	REMOTE	29716	4.8 HRS ARR (OL)		Calisher,J	ONLINE
	Class# 29716 meets 09/08/2020-12/18/2020								
<b>MATH 75 - 6.0 UNITS MATHEMATICAL LITERACY FOR COLLEGE STUDENTS</b>									
Not Transferable									
Prerequisite: MATH 40 or equivalent with a grade of "C" or higher or "Pass" or completion of the math placement process with a score eligible for MATH 60.									
Recommendation: MATH 40 with a grade of "C" or higher or "Pass" within two years prior to enrollment in MATH 75.									
26920	6.0 HRS ARR (OL)		Johnson,J	ONLINE	29736	4.8 HRS ARR (OL)		Torres,M	ONLINE
26921	8:00- 9:50AM	MWF	Lai,K	REMOTE	Class# 29736 meets 09/08/2020-12/18/2020				
27666	10:00-11:50AM	TThF	Ngo,H	REMOTE	29364	8.0 HRS ARR (OL)		Lewandowski,T	ONLINE
29035	6.0 HRS ARR (OL)		Ford,D	ONLINE	Class# 29364 meets 08/17/2020-10/16/2020				
29036	1:30- 4:20PM	TTh	Diaz,C	REMOTE	26473	1:00- 2:50PM	MTWTh	Mariani,I	REMOTE
	Targeted for Future Teachers but Open to all Students								
	Class# 26473 meets 08/17/2020-10/15/2020								
20316	8.0 HRS ARR (OL)		Pham,A	ONLINE	20316	8.0 HRS ARR (OL)		Pham,A	ONLINE
	Class# 20316 meets 08/17/2020-10/15/2020								
<b>22841</b>	<b>8:00- 9:50PM</b>	<b>MTWTh</b>	Burniston,M	REMOTE	<b>22841</b>	<b>8:00- 9:50PM</b>	<b>MTWTh</b>	Burniston,M	REMOTE
	Class# 22841 meets 08/17/2020-10/15/2020								
29706	7:00- 8:50AM	MTWTh	Cho,A	REMOTE	29706	7:00- 8:50AM	MTWTh	Cho,A	REMOTE
	Class# 29706 meets 08/17/2020-10/15/2020								
22326	8.0 HRS ARR (OL)		Beyene,A	ONLINE	22326	8.0 HRS ARR (OL)		Beyene,A	ONLINE
	Class# 22326 meets 10/19/2020-12/17/2020								
<b>29708</b>	<b>5:00- 6:50PM</b>	<b>MTWTh</b>	Takeuchi,K	REMOTE	<b>29708</b>	<b>5:00- 6:50PM</b>	<b>MTWTh</b>	Takeuchi,K	REMOTE
	Class# 29708 meets 10/19/2020-12/17/2020								

### MATH 80A - 3.0 UNITS INTERMEDIATE ALGEBRA I

Not Transferable

Prerequisite: MATH 60 or equivalent with a grade of "C" or higher or "Pass" or completion of the math placement process with a score eligible for MATH 80A. Recommendation: Meet the prerequisite within two years prior to the date of enrollment in MATH 80A.

20323	3.0 HRS ARR (OL)		Campeau,L	ONLINE
*(SEMI-INDEP SECT - LC209)				
20325	3.0 HRS ARR (OL)		Campeau,L	ONLINE
*(SEMI-INDEP SECT - LC209)				
20326	3.0 HRS ARR (OL)		Worrel,D	ONLINE
*(SEMI-INDEP SECT - LC209)				
20328	3.0 HRS ARR (OL)		Worrel,D	ONLINE
*(SEMI-INDEP SECT - LC209)				
20734	3.0 HRS ARR (OL)		Worrel,D	ONLINE
*(SEMI-INDEP SECT - LC209)				
29066	3.0 HRS ARR (OL)		Campeau,L	ONLINE
*(SEMI-INDEP SECT - LC209)				
29714	7:55- 8:45AM	TThF	STAFF	REMOTE
Class# 29714 meets 08/25/2020-12/18/2020				
29725	7:55- 8:45AM	TThF	STAFF	REMOTE
Class# 29725 meets 08/25/2020-12/18/2020				

### MATH 80B - 3.0 UNITS INTERMEDIATE ALGEBRA II

Not Transferable

Prerequisite: MATH 80A or equivalent with a grade of "C" or higher or "Pass."

20330	3.0 HRS ARR (OL)		Campeau,L	ONLINE
*(SEMI-INDEP SECT - LC209)				
20331	3.0 HRS ARR (OL)		Campeau,L	ONLINE
*(SEMI-INDEP SECT - LC209)				
20332	3.0 HRS ARR (OL)		Worrel,D	ONLINE
*(SEMI-INDEP SECT - LC209)				
20334	3.0 HRS ARR (OL)		Worrel,D	ONLINE
*(SEMI-INDEP SECT - LC209)				
20737	3.0 HRS ARR (OL)		Campeau,L	ONLINE
*(SEMI-INDEP SECT - LC209)				
29067	3.0 HRS ARR (OL)		Worrel,D	ONLINE
*(SEMI-INDEP SECT - LC209)				



**ONLINE TUTORING HOURS:**

Monday – Thursday: 9 am - 9 pm  
Friday: 10 am - 2 pm  
Saturday: 10 am - 3 pm

**Drop-In Zoom Tutoring:**  
Success Center faculty and tutors are available to help you with your coursework online during Success Center open hours using Zoom.

**One-On-One Online Zoom Tutoring Appointments:**  
Make an appointment for a 25 minute, one-on-one appointment via Zoom.

**Smarthinking Anytime:**  
Smarthinking is an online tutoring service, accessible 24/7 via your Canvas account.

**ASK US: CHAT**  
Chat is available during regular online business hours to assist with any appointment scheduling issues and general questions.

### MATH 80 - 4.0 UNITS INTERMEDIATE ALGEBRA

Not Transferable

Prerequisite: MATH 60 or equivalent with a grade of "C" or higher or "Pass" or completion of the math placement process with a score eligible for MATH 80. Recommendation: Meet the prerequisite within two years prior to the date of enrollment in MATH 80.

30626	3:00- 4:50PM	MW	Cho,A	REMOTE
20311	4.0 HRS ARR (OL)		Campeau,L	ONLINE
*(SEMI-INDEP SECT - LC209)				
20312	4.0 HRS ARR (OL)		Campeau,L	ONLINE
*(SEMI-INDEP SECT - LC209)				
26923	4.0 HRS ARR (OL)		McCance,I	ONLINE
20315	4.0 HRS ARR (OL)		Worrel,D	ONLINE
*(SEMI-INDEP SECT - LC209)				
20317	4.0 HRS ARR (OL)		Worrel,D	ONLINE
*(SEMI-INDEP SECT - LC209)				
20318	4.0 HRS ARR (OL)		Torres,M	ONLINE
20321	4.0 HRS ARR (OL)		Beyene,A	ONLINE
20731	4.0 HRS ARR (OL)		Worrel,D	ONLINE
*(SEMI-INDEP SECT - LC209)				

If a class displays as **REMOTE** in the schedule, students will be expected to log into the class at a specified day/time (e.g., MW 8-9:15am). If the class displays as **ONLINE** in the schedule, students are permitted to log into the class whenever they are available to complete coursework by the established deadlines.

Students not in attendance or late for the first class meeting are subject to drop.

Class#	Time	Day	Instructor	Room	Class#	Time	Day	Instructor	Room
<b>MATH 110A - 3.0 UNITS MATHEMATICS FOR ELEMENTARY TEACHERS</b>					<b>29042 7:00- 8:50PM MW</b> Diaz,C REMOTE				
Transferable to UC, CSU					Note: Students enrolled in this course must also enroll in MATH 5, #29051				
Prerequisite: MATH 80 or MATH 80B or equivalent with a grade of "C" or higher or "Pass" or completion of the math placement process with a score eligible for MATH courses numbered 100 level or higher and MATH 70 or equivalent with a grade of "C" or higher or "Pass."					29043 11:30- 1:20PM TTh Sarvi,K REMOTE				
22655 4:00- 5:30PM TTh Perez,L REMOTE					Note: Students enrolled in this course must also enroll in MATH 5, #29052				
Targeted for Future Teachers but Open to all Students					29044 4:0 HRS ARR (OL) Valentine,M ONLINE				
5:30- 5:50PM TTh Perez,L REMOTE					Note: Students enrolled in this course must also enroll in MATH 5, #29053				
Targeted for Future Teachers but Open to all Students					29371 4.0 HRS ARR (OL) Huang,F ONLINE				
29015 4:00- 5:30PM MW Cedeno,J REMOTE					29373 4.0 HRS ARR (OL) Morales,M ONLINE				
Targeted for Future Teachers but Open to all Students					29374 4.0 HRS ARR (OL) Niu,K ONLINE				
5:30- 5:50PM MW Cedeno,J REMOTE					29375 4.0 HRS ARR (OL) Phan,H ONLINE				
Targeted for Future Teachers but Open to all Students					29376 4.0 HRS ARR (OL) Tran,T ONLINE				
					29379 4.0 HRS ARR (OL) Yu,A ONLINE				
					29383 4.0 HRS ARR (OL) Huang,F ONLINE				
					<b>29384 6:00- 7:50PM TTh</b> Igolnikov,M REMOTE				
					28736 4.8 HRS ARR (OL) Bateman,M ONLINE				
					Class# 28736 meets 09/08/2020-12/18/2020				
					29723 10:00-12:10PM MW Chung,P REMOTE				
					Class# 29723 meets 09/08/2020-12/18/2020				
					29724 10:00-12:10PM TTh Murugiah,Y REMOTE				
					Class# 29724 meets 09/08/2020-12/18/2020				
					29388 11:00-12:50PM TTh Pham,M REMOTE				
					Class# 29388 meets 09/08/2020-12/17/2020				
					29368 12:00- 2:15PM FSat Riasati,M REMOTE				
					Class# 29368 meets 08/21/2020-12/12/2020				
					29369 8.0 HRS ARR (OL) Gonzalez,A ONLINE				
					Class# 29369 meets 08/17/2020-10/15/2020				
					29377 8.0 HRS ARR (OL) Calisher,J ONLINE				
					Class# 29377 meets 08/17/2020-10/15/2020				
					29389 8.0 HRS ARR (OL) Calisher,J ONLINE				
					Class# 29389 meets 10/19/2020-12/17/2020				
					29391 8.0 HRS ARR (OL) Gonzalez,A ONLINE				
					Class# 29391 meets 10/19/2020-12/17/2020				
<b>MATH 110B - 3.0 UNITS MATHEMATICS FOR ELEMENTARY TEACHERS</b>					<b>MATH 114 - 4.0 UNITS COLLEGE ALGEBRA</b>				
Transferable to UC, CSU					Transferable to UC, CSU				
Prerequisite: MATH 110A or equivalent with a grade of "C" or higher or "Pass."					Prerequisite: MATH 80 or MATH 80B or equivalent with a grade of "C" or higher or "Pass" or completion of the math placement process with a score eligible for MATH courses 100 level or higher.				
<b>30338 6:00- 7:30PM TTh</b> Perez,L REMOTE					20341 1:00- 2:50PM MW El Abyad,A REMOTE				
Targeted for Future Teachers but Open to all Students					Note: Students enrolled in this course must also enroll in MATH 5, #29018				
<b>7:30- 7:50PM TTh</b> Perez,L REMOTE					20342 10:00-11:50AM MW Mariani,I REMOTE				
Targeted for Future Teachers but Open to all Students					Targeted for Future Teachers but Open to all Students				
					Note: Students enrolled in this course must also enroll in MATH 5, #29017				
					20343 4.0 HRS ARR (OL) Campeau,L ONLINE				
					*(SEMI-INDEP SECT - LC209)				
					30332 12:00- 1:50PM MW Budarin,D REMOTE				
					Note: Students enrolled in this course must also enroll in MATH 5, #29061				
					25895 4.0 HRS ARR (OL) Lewandowski,P ONLINE				
					26016 11:00-12:50PM TTh Nguimdjou,E REMOTE				
					Note: Students enrolled in this course must also enroll in MATH 5, #29022				
					20739 4.0 HRS ARR (OL) Worrel,D ONLINE				
					*(SEMI-INDEP SECT - LC209)				
					<b>20740 6:00- 7:50PM MW</b> Roque,T REMOTE				
					Note: Students enrolled in this course must also enroll in MATH 5, #29020				
					20741 4.0 HRS ARR (OL) Campeau,L ONLINE				
					Note: Students enrolled in this course must also enroll in MATH 5, #29019				
					20742 4.0 HRS ARR (OL) Campeau,L ONLINE				
					*(SEMI-INDEP SECT - LC209)				
					<b>21752 8:00- 9:50PM TTh</b> Igolnikov,M REMOTE				
					22806 8:00- 9:50AM TTh Hugen,M REMOTE				
					Note: Students enrolled in this course must also enroll in MATH 5, #29021				
					22391 4.0 HRS ARR (OL) Beyene,A ONLINE				
					23415 4.0 HRS ARR (OL) Worrel,D ONLINE				
					*(SEMI-INDEP SECT - LC209)				
					29023 4:00- 5:50PM TTh Pallwitz,K REMOTE				
					Note: Students enrolled in this course must also enroll in MATH 5, #29024				
					29025 1:00- 2:50PM TTh Hugen,M REMOTE				
					Note: Students enrolled in this course must also enroll in MATH 5, #29026				
					29032 11:00-12:50PM MTWTh Hugen,M REMOTE				
					29033 4.0 HRS ARR (OL) Calisher,J ONLINE				
					29392 4.0 HRS ARR (OL) Torres,M ONLINE				
					29394 7:00- 8:50AM TTh Pham,M REMOTE				
					29399 4.0 HRS ARR (OL) Godwin,S ONLINE				
					29400 4.0 HRS ARR (OL) Godwin,S ONLINE				
					22300 7:30- 9:45AM MW Budarin,D REMOTE				
					Class# 22300 meets 09/09/2020-12/16/2020				
<b>MATH 112 - 4.0 UNITS ELEMENTARY STATISTICS</b>									
Transferable to UC, CSU (CAN STAT 2)									
Prerequisite: Math 80 or Math 80B or Math 75 or equivalent with a grade of "C" or "Pass" or higher or satisfactory completion of the math assessment/placement process with eligibility for Math 112.									
20338 4.0 HRS ARR (OL) Tran,L ONLINE									
Note: Students enrolled in this course must also enroll in MATH 5, #29058									
20339 4.0 HRS ARR (OL) Morales,M ONLINE									
Note: Students enrolled in this course must also enroll in MATH 5, #29045									
This MATH 112 class is part of the Health Occupations House in the First Year Experience Program, which includes COUN 200 (#22518), ENGL 100 (#27865), MATH 5 (#29045), and SOC 101 (#20550). To learn more about FYE and to enroll in this house, please visit <a href="https://www.cerritos.edu/lcp/fye.htm">https://www.cerritos.edu/lcp/fye.htm</a> .									
20340 11:00-12:50PM TTh Flores,W REMOTE									
Note: Students enrolled in this course must also enroll in MATH 5, #29063									
22042 4.0 HRS ARR (OL) Nikdel,M ONLINE									
21301 4.0 HRS ARR (OL) O'Neil,S ONLINE									
Note: Students enrolled in this course must also enroll in MATH 5, #29028									
21302 4.0 HRS ARR (OL) Budarin,D ONLINE									
<b>21461 5:00- 6:50PM TTh</b> Yi,P REMOTE									
Note: Students enrolled in this course must also enroll in MATH 5, #29065									
24343 4.0 HRS ARR (OL) Morales,M ONLINE									
This MATH 112 class is part of the Arts, Humanities, & Communication House in the First Year Experience Program, which includes COUN 200 (#30497), ENGL 100 (#26510), and MATH 5 (#29060). To learn more about FYE and to enroll in this house, please visit <a href="https://www.cerritos.edu/lcp/fye.htm">https://www.cerritos.edu/lcp/fye.htm</a> .									
Note: Students enrolled in this course must also enroll in MATH 5, #29060									
24344 4.0 HRS ARR (OL) Bateman,M ONLINE									
Note: Students enrolled in this course must also enroll in MATH 5, #29057									
24346 4.0 HRS ARR (OL) Mariani,I ONLINE									
Targeted for Future Teachers but Open to all Students									
26199 4.0 HRS ARR (OL) O'Neil,S ONLINE									
Note: Students enrolled in this course must also enroll in MATH 5, #29046									
26917 2:00- 3:50PM TTh Flores,W REMOTE									
Note: Students enrolled in this course must also enroll in MATH 5, #29064									
26918 4.0 HRS ARR (OL) O'Neil,S ONLINE									
26919 4.0 HRS ARR (OL) Aguilar Bastida,R ONLINE									
Note: Students enrolled in this course must also enroll in MATH 5, #29059									
27341 4.0 HRS ARR (OL) O'Neil,S ONLINE									
Note: Students enrolled in this course must also enroll in MATH 5, #29056									
27342 4.0 HRS ARR (OL) Budarin,D ONLINE									
Note: Students enrolled in this course must also enroll in MATH 5, #29055									
<b>27670 5:30- 7:20PM MW</b> Conley,A REMOTE									
Note: Students enrolled in this course must also enroll in MATH 5, #29062									
28157 4.0 HRS ARR (OL) Nikdel,M ONLINE									
Note: Students enrolled in this course must also enroll in MATH 5, #29047									
28842 4.0 HRS ARR (OL) Morales,M ONLINE									
29038 4.0 HRS ARR (OL) Lewandowski,T ONLINE									
29039 4.0 HRS ARR (OL) Nikdel,M ONLINE									
29040 12:00- 1:50PM MW Conley,A REMOTE									
Note: Students enrolled in this course must also enroll in MATH 5, #29049									

If a class displays as **REMOTE** in the schedule, students will be expected to log into the class at a specified day/time (e.g., MW 8-9:15am). If the class displays as **ONLINE** in the schedule, students are permitted to log into the class whenever they are available to complete coursework by the established deadlines.

Students not in attendance or late for the first class meeting are subject to drop.

Class#	Time	Day	Instructor	Room	Class#	Time	Day	Instructor	Room
<b>29367</b>	<b>7:00-9:10PM</b>	<b>TTh</b>	Can,M	REMOTE	<b>MATH 170 - 4.0 UNITS ANALYTIC GEOMETRY AND CALCULUS I</b>				
	Class# 29367 meets 09/08/2020-12/17/2020				Transferable to UC, CSU (CAN MATH 18)(CAN MATH SEQ C)				
29401	9:00-11:15AM	FSat	Riasati,M	REMOTE	Prerequisite: MATH 150 or MATH 155 or equivalent with a grade of "C" or higher or "Pass" or completion of the math placement process with a score eligible for MATH 170.				
	Class# 29401 meets 08/21/2020-12/12/2020				20354	2:00- 3:50PM	MW	Cortez,D	REMOTE
29395	7:00- 8:50AM	MTWTh	Cho,A	REMOTE	20355	4.0 HRS ARR	(OL)	Trinh,T	ONLINE
	Class# 29395 meets 08/17/2020-10/15/2020				20356	1:00- 2:50PM	TTh	George,P	REMOTE
29439	1:00- 2:50PM	MTWTh	Mariani,l	REMOTE	<b>20749</b>	<b>5:30- 7:20PM</b>	<b>MW</b>	George,P	REMOTE
	Targeted for Future Teachers but Open to all Students				22255	4.0 HRS ARR	(OL)	McCance,I	ONLINE
	Class# 29439 meets 10/19/2020-12/17/2020				28408	4.0 HRS ARR	(OL)	Byun,E	ONLINE
<b>MATH 116 - 4.0 UNITS CALCULUS FOR MANAGERIAL, BIOLOGICAL AND SOCIAL SCIENCES</b>					29034	8.0 HRS ARR	(OL)	Lopez,M	ONLINE
Transferable to UC, CSU (CAN MATH 34)					Class# 29034 meets 08/17/2020-10/15/2020				
Prerequisite: MATH 114 or equivalent with a grade of "C" or higher or "Pass" or completion of the math placement process with a score eligible for MATH 116.					<b>MATH 190 - 4.0 UNITS ANALYTIC GEOMETRY AND CALCULUS II</b>				
<b>20743</b>	<b>6:00- 7:50PM</b>	<b>TTh</b>	Hultman,J	REMOTE	Transferable to UC, CSU (CAN MATH 20)(CAN MATH SEQ C)				
21274	4.0 HRS ARR	(OL)	Chrispens,A	ONLINE	Prerequisite: MATH 170 or equivalent with a grade of "C" or higher or "Pass."				
29403	4.0 HRS ARR	(OL)	Beyene,A	ONLINE	20357	4.0 HRS ARR	(OL)	McCance,I	ONLINE
<b>MATH 140 - 3.0 UNITS TRIGONOMETRY</b>					20750	4.0 HRS ARR	(OL)	McCance,I	ONLINE
Transferable to CSU (CAN MATH 8)					22393	4.0 HRS ARR	(OL)	Lewandowski,P	ONLINE
Prerequisite: MATH 80 or MATH 80B or equivalent with a grade of "C" or higher or "Pass" or completion of the math placement process with a score eligible for MATH courses numbered 100 level or higher and MATH 70 or equivalent with a grade of "C" or higher or "Pass."					29014	4.0 HRS ARR	(OL)	Trinh,T	ONLINE
<b>22808</b>	<b>6:00- 7:15PM</b>	<b>MW</b>	Bonakdar,M	REMOTE	29705	8.0 HRS ARR	(OL)	Lopez,M	ONLINE
20349	3.0 HRS ARR	(OL)	Campeau,L	ONLINE	Class# 29705 meets 10/19/2020-12/17/2020				
	*(SEMI-INDEP SECT - LC209)				<b>MATH 225 - 5.0 UNITS CALCULUS III</b>				
22809	3.0 HRS ARR	(OL)	Lewandowski,P	ONLINE	Transferable to UC, CSU				
20350	3.0 HRS ARR	(OL)	Worrel,D	ONLINE	Prerequisite: MATH 190 or equivalent with a grade of "C" or higher or "Pass."				
	*(SEMI-INDEP SECT - LC209)				27209	8:30-10:45AM	TTh	Conley,A	REMOTE
20744	3.0 HRS ARR	(OL)	Worrel,D	ONLINE	27210	5.0 HRS ARR	(OL)	Leon Jr.,R	ONLINE
	*(SEMI-INDEP SECT - LC209)				<b>MATH 250 - 5.0 UNITS LINEAR ALGEBRA AND DIFFERENTIAL EQUATIONS</b>				
20745	3.0 HRS ARR	(OL)	Worrel,D	ONLINE	Transferable to UC, CSU				
	*(SEMI-INDEP SECT - LC209)				Prerequisite: MATH 190 or equivalent with a grade of "C" or higher or "Pass."				
20746	3.0 HRS ARR	(OL)	Campeau,L	ONLINE	Recommendation: MATH 220 or MATH 225 or equivalent with a grade of "C" or higher or "Pass."				
	*(SEMI-INDEP SECT - LC209)				24348	5.0 HRS ARR	(OL)	Nikdel,M	ONLINE
20747	3.0 HRS ARR	(OL)	Phan,H	ONLINE	30340	5.0 HRS ARR	(OL)	Leon Jr.,R	ONLINE
29012	3.0 HRS ARR	(OL)	Leon Jr.,R	ONLINE	<h2 style="margin: 0;">MEDICAL ASSISTANT</h2>				
30330	4:00- 5:15PM	TTh	Can,M	REMOTE					
Note: Students enrolled in this course must also enroll in MATH 5, #30628									
<b>29404</b>	<b>7:30- 8:45PM</b>	<b>MW</b>	Can,M	REMOTE					
Note: Students enrolled in this course must also enroll in MATH 5, #30627									
29407	4:00- 5:15PM	MW	Daigle,M	REMOTE					
30333	7:30- 8:45AM	MW	Hugen,M	REMOTE					
30335	1:30- 2:45PM	MW	Daigle,M	REMOTE					
Note: Students enrolled in this course must also enroll in MATH 5, #30629									
30336	3.0 HRS ARR	(OL)	Leon Jr.,R	ONLINE					
29737	3.6 HRS ARR	(OL)	Pham,A	ONLINE					
	Class# 29737 meets 09/08/2020-12/18/2020								
30334	10:15-11:50AM	MW	Budarin,D	REMOTE					
	Class# 30334 meets 08/17/2020-11/25/2020								
28409	9:00-10:35AM	MW	Hugen,M	REMOTE					
	Class# 28409 meets 09/09/2020-12/16/2020								
29365	6.0 HRS ARR	(OL)	Lewandowski,T	ONLINE					
	Class# 29365 meets 10/19/2020-12/17/2020								
<b>29405</b>	<b>8:00- 9:15PM</b>	<b>MTWTh</b>	Burniston,M	REMOTE					
	Class# 29405 meets 10/19/2020-12/17/2020								
<b>MATH 155 - 5.0 UNITS PRECALCULUS</b>									
Transferable to CSU									
Prerequisite: MATH 140 or equivalent with a grade of "C" or higher or "Pass" or completion of the math placement process with a score eligible for MATH 155.									
<b>26460</b>	<b>5:00- 7:15PM</b>	<b>TTh</b>	George,P	REMOTE					
26461	5.0 HRS ARR	(OL)	Trinh,T	ONLINE					
26462	11:00- 1:15PM	TTh	Ninh,J	REMOTE					
26463	5.0 HRS ARR	(OL)	Byun,E	ONLINE					
<b>26464</b>	<b>7:30- 9:45PM</b>	<b>TTh</b>	Osborne,C	REMOTE					
<b>28410</b>	<b>7:30- 9:45PM</b>	<b>MW</b>	George,P	REMOTE					
29013	5.0 HRS ARR	(OL)	Byun,E	ONLINE					
30329	5.0 HRS ARR	(OL)	Campeau,L	ONLINE					

If a class displays as **REMOTE** in the schedule, students will be expected to log into the class at a specified day/time (e.g., MW 8-9:15am). If the class displays as **ONLINE** in the schedule, students are permitted to log into the class whenever they are available to complete coursework by the established deadlines.

Students not in attendance or late for the first class meeting are subject to drop.

Class#	Time	Day	Instructor	Room	Class#	Time	Day	Instructor	Room
<b>MA 67 - 3.0 UNITS MEDICAL OFFICE ADMINISTRATION</b> Not Transferable Prerequisite: MA 60. Recommendation: BCOT 62 and BCOT 3T or equivalent with grades of Pass or "C" or higher.									
26863	3.0 HRS ARR	(OL)	Vidal,L	ONLINE					
<b>MA 68 - 4.0 UNITS MEDICAL ASSISTING INTERNSHIP EXPERIENCE</b> Not Transferable Prerequisite: MA 60, MA 62A and MA 62B or MA 63, and MA 64, MA 161, HO 53, HO 54, HO 55 or equivalent with grades of "C" or higher or "Pass." Corequisite: MA 66 and MA 67 or prior completion with a grade of "Pass" or "C" or higher.									
26864	9:00- 9:50AM +10.0 HRS ARR	F	Friend,J STAFF	REMOTE					
<b>MA 73 - 3.0 UNITS MEDICAL ASSISTANT OCCUPATIONAL WORK EXPERIENCE</b> Not Transferable Prerequisite: MA 60, MA 62A and MA 62B or MA 63, and MA 64, MA 161, HO 53, HO 54, HO 55 or equivalent with grades of "C" or higher or "Pass." Corequisite: MA 66 and MA 67 or prior completion with a grade of "Pass" or "C" or higher.									
30057	9:00- 9:50AM	F	Friend,J	REMOTE					
<b>MA 74 - 4.0 UNITS MEDICAL ASSISTANT OCCUPATIONAL WORK EXPERIENCE</b> Not Transferable Prerequisite: MA 60, MA 62A and MA 62B or MA 63, and MA 64, MA 161, HO 53, HO 54, HO 55 or equivalent with grades of "C" or higher or "Pass." Corequisite: MA 66 and MA 67 or prior completion with a grade of "Pass" or "C" or higher.									
30058	9:00- 9:50AM	F	Friend,J	REMOTE					
<b>MA 161 - 3.0 UNITS MEDICAL TERMINOLOGY</b> Transferable to CSU									
20277	3.0 HRS ARR	(OL)	Vidal,L	ONLINE					
20718	3.0 HRS ARR	(OL)	Artates,E	ONLINE					
21341	3.0 HRS ARR	(OL)	Schmidt,C	ONLINE					
24196	3.0 HRS ARR	(OL)	Artates,E	ONLINE					
<b>MUSIC</b>									
<b>20755 7:00- 9:50PM TTh</b> Seanez,B REMOTE Computer (Windows PC or Mac - no tablets, phones) with a microphone & webcam are required for assessments and assignments. Any live lectures will occur during scheduled class times via the Zoom platform. Please see Canvas for more information.									
<b>MUS 100 - 3.0 UNITS MUSIC APPRECIATION</b>									
Transferable to UC, CSU									
20361	3.0 HRS ARR	(OL)	Lee,S	ONLINE	FIELD TRIPS TO LOCAL MUSIC PRODUCTIONS MAY BE REQUIRED. If so students provide their own tickets – please check with your instructor for specific event information.				
23964	3.0 HRS ARR	(OL)	Dimond,T	ONLINE					
24371	3.0 HRS ARR	(OL)	Dillon,R	ONLINE					
27048	3.0 HRS ARR	(OL)	Pacier,P	ONLINE					
<b>MUS 101 - 3.0 UNITS INTRODUCTION TO WORLD MUSIC</b> Transferable to UC, CSU									
20363	3.0 HRS ARR	(OL)	Pacier,P	ONLINE					
<b>MUS 104B - 3.0 UNITS HISTORY OF ROCK MUSIC</b> Transferable to UC, CSU									
20757	3.0 HRS ARR	(OL)	Betancourt,D	ONLINE					
21860	3.0 HRS ARR	(OL)	Simmons,J	ONLINE					
25998	3.0 HRS ARR	(OL)	Simmons,J	ONLINE					
22128	6.0 HRS ARR	(OL)	Simmons,J	ONLINE	Class# 22128 meets 08/17/2020-10/14/2020				
<b>MUS 105 - 3.0 UNITS MUSIC FUNDAMENTALS</b> Transferable to UC, CSU									
20364	3.0 HRS ARR	(OL)	DeMichele,A	ONLINE					
22711	3.0 HRS ARR	(OL)	DeMichele,A	ONLINE					
20365	3.0 HRS ARR	(OL)	Betancourt,D	ONLINE	Note: This is an ONLINE course – all instruction is completed online. No in-person orientation. Please check Canvas for online orientation information and directions for completion (instructor e-mail address: clopez@cerritos.edu).				
20366	3.0 HRS ARR	(OL)	Tsai,S	ONLINE					
20368	3.0 HRS ARR	(OL)	Da Silva,P	ONLINE					
27692	3.0 HRS ARR	(OL)	Betancourt,D	ONLINE	Note: This is an ONLINE course – all instruction is completed online. No in-person orientation. Please check Canvas for online orientation information and directions for completion (instructor e-mail address: dbetancourt@cerritos.edu).				
<b>MUS 110 - 3.0 UNITS MUSIC TECHNOLOGY FUNDAMENTALS</b> Transferable to CSU Recommendation: Completion of MUS 105 or equivalent with a grade of "C" or higher or "Pass" and completion of ENGL 52 or ENGL 72 or ESL 152 or equivalent with a grade of "C" or higher or "Pass" or completion of the English assessment/ placement process with a score eligible for ENGL 100 or ENGL 100S.									
24373	3.0 HRS ARR	(OL)	Maz,A	ONLINE	This course covers the fundamental vocabulary, techniques, concepts, and devices used in contemporary music production and related media fields. Topics include sound fundamentals, professional audio equipment, computers, music production software, recording studios, MIDI, electronic music, audio-visual productions, and film. This course is required of all Commercial Music majors and is a prerequisite for all other commercial music courses. Note: Students must have access to a six-string acoustic or electric guitar. For more information, please contact Dr. Andrew Maz at amaz@cerritos.edu.				
<b>MUS 112 - 2.0 UNITS ELEMENTARY PIANO I</b> Transferable to UC, CSU (CAN MUS 22)									
20370	2.0 HRS ARR + 1.0 HRS ARR	(OL) (OL)	Lee,S Lee,S	ONLINE ONLINE	Note: Students must have access to a piano or a digital keyboard. The keyboard should have a minimum of 61 full-size keys. For more information, please contact Dr. Christine Lopez at clopez@cerritos.edu.				
20759	2.0 HRS ARR + 1.0 HRS ARR	(OL) (OL)	Chen,J Chen,J	ONLINE ONLINE	Note: Students must have access to a piano or a digital keyboard. The keyboard should have a minimum of 61 full-size keys. For more information, please contact Dr. Christine Lopez at clopez@cerritos.edu.				
<b>MICROBIOLOGY</b>									
<b>MICR 200 - 5.0 UNITS PRINCIPLES AND APPLICATIONS OF MICROBIOLOGY</b> Transferable to UC, CSU (CAN BIOL 14) Prerequisite: CHEM 100 or BIOL 120 or ZOOL 120 or equivalent with a grade of "C" or higher or "Pass."									
20358	12:30- 1:45PM	MW	Rojas,S	REMOTE	Computer (Windows PC or Mac - no tablets, phones) with a microphone & webcam are required for assessments and assignments. Any live lectures will occur during scheduled class times via the Zoom platform. Please see Canvas for more information.				
20359	9:00-11:50AM	MW	Rojas,S	REMOTE	Computer (Windows PC or Mac - no tablets, phones) with a microphone & webcam are required for assessments and assignments. Any live lectures will occur during scheduled class times via the Zoom platform. Please see Canvas for more information.				
20360	2:00- 4:50PM	MW	Cocca,S	REMOTE	Computer (Windows PC or Mac - no tablets, phones) with a microphone & webcam are required for assessments and assignments. Any live lectures will occur during scheduled class times via the Zoom platform. Please see Canvas for more information.				
21492	1:30- 4:20PM	TTh	Rojas,S	REMOTE	Computer (Windows PC or Mac - no tablets, phones) with a microphone & webcam are required for assessments and assignments. Any live lectures will occur during scheduled class times via the Zoom platform. Please see Canvas for more information.				
20753	5:30- 6:45PM	TTh	Rojas,S	REMOTE	Computer (Windows PC or Mac - no tablets, phones) with a microphone & webcam are required for assessments and assignments. Any live lectures will occur during scheduled class times via the Zoom platform. Please see Canvas for more information.				

If a class displays as **REMOTE** in the schedule, students will be expected to log into the class at a specified day/time (e.g., MW 8-9:15am). If the class displays as **ONLINE** in the schedule, students are permitted to log into the class whenever they are available to complete coursework by the established deadlines.

Students not in attendance or late for the first class meeting are subject to drop.



Class#	Time	Day	Instructor	Room	Class#	Time	Day	Instructor	Room
21297	2.0 HRS ARR + 1.0 HRS ARR	(OL) (OL)	Lopez,C Lopez,C	ONLINE ONLINE	<b>MUS 119 - 2.0 UNITS VOICE IV</b> Transferable to UC, CSU Prerequisite: MUS 118 or equivalent with a grade of Pass or "C" or higher.				
21478	2.0 HRS ARR + 1.0 HRS ARR	(OL) (OL)	Lopez,C Lopez,C	ONLINE ONLINE	21295	2.0 HRS ARR + 1.0 HRS ARR	(OL) (OL)	DeMichele,A DeMichele,A	ONLINE ONLINE
Note: Students must have access to a piano or a digital keyboard. The keyboard should have a minimum of 61 full-size keys. For more information, please contact Dr. Christine Lopez at <a href="mailto:clopez@cerritos.edu">HYPERLINK "mailto:clopez@cerritos.edu"</a> clopez@cerritos.					21678	2.0 HRS ARR + 1.0 HRS ARR	(OL) (OL)	DeMichele,A DeMichele,A	ONLINE ONLINE
<b>MUS 113 - 2.0 UNITS ELEMENTARY PIANO II</b> Transferable to UC, CSU (CAN MUS 24) Prerequisite: MUS 112 or equivalent with a grade of Pass or "C" or higher.					<b>MUS 120 - 2.0 UNITS ELEMENTARY GUITAR I</b> Transferable to UC, CSU				
21312	2.0 HRS ARR + 1.0 HRS ARR	(OL) (OL)	Lopez,C Lopez,C	ONLINE ONLINE	21304	2.0 HRS ARR + 1.0 HRS ARR	(OL) (OL)	Torres,M Torres,M	ONLINE ONLINE
Note: Students must have access to a piano or a digital keyboard. The keyboard should have a minimum of 61 full-size keys. For more information, please contact Dr. Christine Lopez at <a href="mailto:clopez@cerritos.edu">clopez@cerritos.edu</a> .					<b>MUS 121 - 2.0 UNITS ELEMENTARY GUITAR II</b> Transferable to UC, CSU Prerequisite: MUS 120 or equivalent with a grade of Pass or "C" or higher.				
21666	2.0 HRS ARR + 1.0 HRS ARR	(OL) (OL)	Chen,J Chen,J	ONLINE ONLINE	21306	2.0 HRS ARR + 1.0 HRS ARR	(OL) (OL)	Torres,M Torres,M	ONLINE ONLINE
Note: Students must have access to a piano or a digital keyboard. The keyboard should have a minimum of 61 full-size keys. For more information, please contact Dr. Christine Lopez at <a href="mailto:clopez@cerritos.edu">clopez@cerritos.edu</a> .					Note: Students must have access to a six-string acoustic or electric guitar. For more information, please contact Dr. Andrew Maz at <a href="mailto:amaz@cerritos.edu">HYPERLINK "mailto:amaz@cerritos.edu"</a> amaz@cerritos.edu.				
<b>MUS 114 - 2.0 UNITS INTERMEDIATE PIANO I</b> Transferable to UC, CSU Prerequisite: MUS 113 or equivalent with a grade of Pass or "C" or higher.					<b>MUS 122 - 2.0 UNITS INTERMEDIATE GUITAR I</b> Transferable to UC, CSU Prerequisite: MUS 121 or equivalent with a grade of Pass or "C" or higher.				
20372	2.0 HRS ARR + 1.0 HRS ARR	(OL) (OL)	Lopez,C Lopez,C	ONLINE ONLINE	22033	2.0 HRS ARR + 1.0 HRS ARR	(OL) (OL)	Torres,M Torres,M	ONLINE ONLINE
Note: Students must have access to a piano or a digital keyboard. The keyboard should have a minimum of 61 full-size keys. For more information, please contact Dr. Christine Lopez at <a href="mailto:clopez@cerritos.edu">clopez@cerritos.edu</a> .					Note: Students must have access to a six-string acoustic or electric guitar. For more information, please contact Dr. Andrew Maz at <a href="mailto:amaz@cerritos.edu">amaz@cerritos.edu</a> .				
21668	2.0 HRS ARR + 1.0 HRS ARR	(OL) (OL)	Chen,J Chen,J	ONLINE ONLINE	<b>MUS 123 - 2.0 UNITS INTERMEDIATE GUITAR II</b> Transferable to UC, CSU Prerequisite: MUS 122 or equivalent with a grade of Pass or "C" or higher.				
Note: Students must have access to a piano or a digital keyboard. The keyboard should have a minimum of 61 full-size keys. For more information, please contact Dr. Christine Lopez at <a href="mailto:clopez@cerritos.edu">clopez@cerritos.edu</a> .					21317	2.0 HRS ARR + 1.0 HRS ARR	(OL) (OL)	Torres,M Torres,M	ONLINE ONLINE
<b>MUS 115 - 2.0 UNITS INTERMEDIATE PIANO II</b> Transferable to UC, CSU Prerequisite: MUS 114 or equivalent with a grade of Pass or "C" or higher.					Note: Students must have access to a six-string acoustic or electric guitar. For more information, please contact Dr. Andrew Maz at <a href="mailto:amaz@cerritos.edu">amaz@cerritos.edu</a> .				
21310	2.0 HRS ARR + 1.0 HRS ARR	(OL) (OL)	Lopez,C Lopez,C	ONLINE ONLINE	<b>MUS 143A - 2.5 UNITS SONGWRITING</b> Transferable to CSU Prerequisite: MUS 180 or equivalent with a grade of "C" or higher or "Pass." Corequisite: Enrollment in music theory MUS 181.				
Note: Students must have access to a piano or a digital keyboard. The keyboard should have a minimum of 61 full-size keys. For more information, please contact Dr. Christine Lopez at <a href="mailto:clopez@cerritos.edu">clopez@cerritos.edu</a> .					30322	2.0 HRS ARR + 2.0 HRS ARR	(OL) (OL)	Maz,A Maz,A	ONLINE ONLINE
21670	2.0 HRS ARR + 1.0 HRS ARR	(OL) (OL)	Chen,J Chen,J	ONLINE ONLINE	Note: Students must have access to a six-string acoustic or electric guitar. For more information, please contact Dr. Andrew Maz at <a href="mailto:amaz@cerritos.edu">amaz@cerritos.edu</a> .				
Note: Students must have access to a piano or a digital keyboard. The keyboard should have a minimum of 61 full-size keys. For more information, please contact Dr. Christine Lopez at <a href="mailto:clopez@cerritos.edu">clopez@cerritos.edu</a> .					<b>MUS 144B - 2.0 UNITS ELECTRONIC MUSIC PRODUCTION</b> Transferable to CSU Prerequisite: MUS 144 or MUS 144A or equivalent with a grade of "C" or higher or "Pass". Recommendation: Completion of ENGL 52 or ENGL 72 or ESL 152 or equivalents with a grade of "C" or higher or "Pass" or completion of the English assessment/placement process with a score eligible for ENGL 100 or ENGL 100S.				
<b>MUS 116 - 2.0 UNITS VOICE I</b> Transferable to UC, CSU					24367	2.0 HRS ARR + 2.0 HRS ARR	(OL) (OL)	Maz,A Maz,A	ONLINE ONLINE
20373	2.0 HRS ARR + 1.0 HRS ARR	(OL) (OL)	DeMichele,A DeMichele,A	ONLINE ONLINE	This class introduces advanced MIDI, synthesis, and music production techniques used for music, film, and television. Students will receive training on a variety of computer music programs, each suited for a particular task. Several projects will be required of all students. This course is not open to students who have received credit in MUS 145.				
20907	2.0 HRS ARR + 1.0 HRS ARR	(OL) (OL)	DeMichele,A DeMichele,A	ONLINE ONLINE	<b>MUS 146B - 2.5 UNITS MIXING TECHNIQUES</b> Transferable to CSU Prerequisite: Completion of MUS 146A or MUS 146 or equivalent with a grade of "C" or higher or "Pass." Recommendation: Completion of ENGL 52 or ENGL 72 or ESL 152 or equivalent with a grade of "C" or higher or "Pass" or completion of the English assessment/placement process with a score eligible for ENGL 100 or ENGL 100S.				
<b>MUS 117 - 2.0 UNITS VOICE II</b> Transferable to UC, CSU Prerequisite: MUS 116 or equivalent with a grade of Pass or "C" or higher.					26420	2.0 HRS ARR + 2.0 HRS ARR	(OL) (OL)	Maz,A Maz,A	ONLINE ONLINE
20908	2.0 HRS ARR + 1.0 HRS ARR	(OL) (OL)	DeMichele,A DeMichele,A	ONLINE ONLINE	This course covers the methods of audio mixing in the studio, covering a variety of music genres. It includes the technical, as well as the artistic, aspects of mixing. Emphasis will be placed on the practical mixing strategies and techniques. Several mix projects in varying genres will be required of all students.				
21672	2.0 HRS ARR + 1.0 HRS ARR	(OL) (OL)	DeMichele,A DeMichele,A	ONLINE ONLINE					
<b>MUS 118 - 2.0 UNITS VOICE III</b> Transferable to UC, CSU Prerequisite: MUS 117 or equivalent with a grade of Pass or "C" or higher.									
21674	2.0 HRS ARR + 1.0 HRS ARR	(OL) (OL)	DeMichele,A DeMichele,A	ONLINE ONLINE					
21200	2.0 HRS ARR + 1.0 HRS ARR	(OL) (OL)	DeMichele,A DeMichele,A	ONLINE ONLINE					

If a class displays as **REMOTE** in the schedule, students will be expected to log into the class at a specified day/time (e.g., MW 8-9:15am). If the class displays as **ONLINE** in the schedule, students are permitted to log into the class whenever they are available to complete coursework by the established deadlines.

Students not in attendance or late for the first class meeting are subject to drop.

Class#	Time	Day	Instructor	Room	Class#	Time	Day	Instructor	Room
<b>MUS 148 - 1.0 UNIT PRIVATE STUDY/TECHNIQUE</b> Transferable to UC, CSU Prerequisite: Audition Required or MUS 147 with a grade of "C" or higher. Corequisite: Enrollment in a music ensemble: MUS 200E - MUS 208E, MUS 210E - MUS 213E, MUS 217E, or MUS 219E AND Enrollment in music theory: MUS 180, MUS 181, MUS 280, or MUS 281.					<b>MUS 203E - 1.0 UNIT COMMUNITY BAND</b> Transferable to CSU 24363 2.0 HRS ARR (OL) Betancourt,D ONLINE + 2.0 HRS ARR (OL) Betancourt,D ONLINE Instrumental Ensemble Auditions for MUS 202E, 203E, 204E, 205E, 206E, 207E, and 208E are on Saturday, August 12 from 9:00 a.m. to 12:00 p.m., in room BC-53. Contact Dr. Betancourt for further information at (562) 860-2451, extension, 2631 Please contact Dr. David Betancourt at dbetancourt@cerritos.edu for audition information..				
20377	1.0 HRS ARR (OL)		Lopez,C	ONLINE					
	+ 6.0 HRS ARR (OL)		Lopez,C	ONLINE					
Note: Please contact Dr. Christine Lopez at clopez@cerritos.edu for audition information.					<b>MUS 204E - 1.0 UNIT ORCHESTRA</b> Transferable to CSU 24957 2.0 HRS ARR (OL) Betancourt,D ONLINE + 2.0 HRS ARR (OL) Betancourt,D ONLINE Please contact Dr. David Betancourt at HYPERLINK "mailto:dbetancourt@cerritos.edu"dbetancourt@cerritos.edu for audition information.				
<b>MUS 149 - 1.0 UNIT PRIVATE STUDY/MUSICAL PREPARATION</b> Transferable to UC, CSU Prerequisite: Audition Required or MUS 148 with a grade of "C" or higher. Corequisite: Enrollment in a music ensemble: MUS 200E - MUS 208E, MUS 210E - MUS 213E, MUS 217E, or MUS 219E AND Enrollment in music theory: MUS 180, MUS 181, MUS 280, or MUS 281.					<b>MUS 205E - 1.0 UNIT COMMUNITY ORCHESTRA</b> Transferable to UC, CSU 24959 2.0 HRS ARR (OL) Betancourt,D ONLINE + 2.0 HRS ARR (OL) Betancourt,D ONLINE Please contact Dr. David Betancourt at dbetancourt@cerritos.edu for audition information.				
20378	1.0 HRS ARR (OL)		Lopez,C	ONLINE					
	+ 6.0 HRS ARR (OL)		Lopez,C	ONLINE					
Note: Please contact Dr. Christine Lopez at clopez@cerritos.edu for audition information.					<b>MUS 206E - 1.0 UNIT STAGE BAND</b> Transferable to CSU 24961 2.0 HRS ARR (OL) Betancourt,D ONLINE + 2.0 HRS ARR (OL) Betancourt,D ONLINE Please contact Dr. David Betancourt at dbetancourt@cerritos.edu for audition information.				
<b>MUS 150 - 1.0 UNIT PRIVATE STUDY/PERFORMANCE PRACTICE</b> Transferable to UC, CSU Prerequisite: Audition Required or MUS 149 with a grade of "C" or higher. Corequisite: Enrollment in a music ensemble: MUS 200E - MUS 208E, MUS 210E - MUS 213E, MUS 217E, or MUS 219E AND Enrollment in music theory: MUS 180, MUS 181, MUS 280, or MUS 281.					<b>MUS 207E - 1.0 UNIT JAZZ ENSEMBLE</b> Transferable to CSU 24963 2.0 HRS ARR (OL) Betancourt,D ONLINE + 2.0 HRS ARR (OL) Betancourt,D ONLINE Please contact Dr. David Betancourt at dbetancourt@cerritos.edu for audition information.				
20379	1.0 HRS ARR (OL)		Lopez,C	ONLINE					
	+ 6.0 HRS ARR (OL)		Lopez,C	ONLINE					
Note: Please contact Dr. Christine Lopez at clopez@cerritos.edu for audition information.					<b>MUS 208E - 1.0 UNIT POP/ROCK LATIN ENSEMBLE</b> Transferable to UC, CSU 30666 4.0 HRS ARR (OL) Simmons,J ONLINE Please add NOTE: Contact Dr. Andrew Maz for audition information atamaz@cerritos.edu. Class# 30666 meets 10/19/2020-12/18/2020				
<b>MUS 151 - 1.0 UNIT PRIVATE STUDY/RECITAL PREPARATION</b> Transferable to UC, CSU Prerequisite: Audition Required or MUS 150 with a grade of "C" or higher. Corequisite: Enrollment in a music ensemble: MUS 200E - MUS 208E, MUS 210E - MUS 213E, MUS 217E, or MUS 219E AND Enrollment in music theory: MUS 180, MUS 181, MUS 280, or MUS 281.					<b>MUS 210E - 1.0 UNIT STRING ENSEMBLE</b> Transferable to CSU 24967 2.0 HRS ARR (OL) Lopez,C ONLINE + 2.0 HRS ARR (OL) Lopez,C ONLINE Please contact Dr. Christine Lopez at clopez@cerritos.edu for audition information.				
22035	1.0 HRS ARR (OL)		Lopez,C	ONLINE					
	+ 6.0 HRS ARR (OL)		Lopez,C	ONLINE					
Note: Please contact Dr. Christine Lopez at clopez@cerritos.edu for audition information.					<b>MUS 216E - 1.0 UNIT PIANO ENSEMBLE</b> Transferable to CSU Prerequisite: MUS 112 or equivalent with a grade of "C" or higher or "Pass." 25036 2.0 HRS ARR (OL) Lopez,C ONLINE + 2.0 HRS ARR (OL) Lopez,C ONLINE Please contact Dr. Christine Lopez at clopez@cerritos.edu for audition information.				
<b>MUS 153 - 2.0 UNITS THE ART OF TEACHING INTERMEDIATE PIANO</b> Transferable to CSU Prerequisite: MUS 152 or equivalent with a grade of Pass or "C" or higher.					<b>MUS 218E - 1.0 UNIT COMMUNITY CHORUS</b> Transferable to CSU 24969 2.0 HRS ARR (OL) DeMichele,A ONLINE + 2.0 HRS ARR (OL) DeMichele,A ONLINE 24971 2.0 HRS ARR (OL) DeMichele,A ONLINE + 2.0 HRS ARR (OL) DeMichele,A ONLINE Please contact Dr. Anna DeMichele at dmichele@cerritos.edu for audition information.				
26428	2.0 HRS ARR (OL)		Lopez,C	ONLINE					
<b>MUS 156 - 2.5 UNITS CONTEMPORARY MUSIC NOTATION</b> Transferable to CSU Prerequisite: Completion of MUS 105 or equivalent with a grade of "C" or higher or "Pass." Recommendation: Completion of ENGL 52 or ENGL 72 or ESL 152 or equivalent with a grade of "C" or higher or "Pass" or completion of the English assessment/placement process with a score eligible for ENGL 100 or ENGL 100S.					<b>MUS 219E - 1.0 UNIT COLLEGIATE CHORALE</b> Transferable to CSU 24973 2.0 HRS ARR (OL) DeMichele,A ONLINE + 2.0 HRS ARR (OL) DeMichele,A ONLINE 24975 2.0 HRS ARR (OL) DeMichele,A ONLINE + 2.0 HRS ARR (OL) DeMichele,A ONLINE Please contact Dr. Anna DeMichele at dmichele@cerritos.edu for audition information.				
26422	2.0 HRS ARR (OL)		Maz,A	ONLINE					
	+ 2.0 HRS ARR (OL)		Maz,A	ONLINE					
Note: Students will learn to create professional vocal scores, lead sheets, piano reductions, arrangements, tablatures, and worksheets. Students must have access to a Windows or Macintosh computer for this course. Students will also need access to the latest version of Avid Sibelius music notation software. For more information, please contact Dr. Andrew Maz at amaz@cerritos.edu.									
<b>MUS 180 - 4.0 UNITS MUSIC THEORY/MUSICIANSHIP I</b> Transferable to UC, CSU Prerequisite: MUS 105 or equivalent with a grade of "Pass" or "C" or higher.									
24385	4.0 HRS ARR (OL)		Lopez,C	ONLINE					
	+ 1.0 HRS ARR (OL)		Lopez,C	ONLINE					
<b>MUS 200E - 1.0 UNIT BEGINNING BAND</b> Transferable to CSU 24361 2.0 HRS ARR (OL) Betancourt,D ONLINE + 2.0 HRS ARR (OL) Betancourt,D ONLINE Please contact Dr. David Betancourt at dbetancourt@cerritos.edu for audition information.									

If a class displays as **REMOTE** in the schedule, students will be expected to log into the class at a specified day/time (e.g., MW 8-9:15am). If the class displays as **ONLINE** in the schedule, students are permitted to log into the class whenever they are available to complete coursework by the established deadlines.

Students not in attendance or late for the first class meeting are subject to drop.

Class#	Time	Day	Instructor	Room	Class#	Time	Day	Instructor	Room
<b>MUS 280 - 4.0 UNITS MUSIC THEORY/MUSICIANSHIP III</b> Transferable to UC, CSU Prerequisite: MUS 107 or MUS 181 or equivalent with a grade of "Pass" or "C" or higher.					<b>NRSRG 210 - 5.0 UNITS FUNDAMENTALS OF NURSING</b> Transferable to CSU Corequisite: NRSRG 211 NOTE: a material fee of \$45.25 is required for NRSRG 210				
25547	4.0 HRS ARR	(OL)	Da Silva,P	ONLINE	20860	+ 6.0 HRS ARR	(OL)	Brown Farr,N	ONLINE
	+ 1.0 HRS ARR	(OL)	Da Silva,P	ONLINE	PLEASE ENROLL IN LAB SECTION AS ASSIGNED. THE LECTURE SECTION #20860 WILL BE AUTOMATICALLY ADDED.				
Please contact Dr. Anna DeMichele at dmichele@cerritos.edu for audition information.					Class# 20860 meets 08/17/2020-10/15/2020				
NURSING					20861	12.0 HRS ARR	(OL)	Brown Farr,N	ONLINE
					Class# 20861 meets 08/17/2020-10/15/2020				
					20862	12.0 HRS ARR	(OL)	Montez-Ochoa,V	ONLINE
					Class# 20862 meets 08/17/2020-10/15/2020				
					20863	12.0 HRS ARR	(OL)	Gemmill,O	ONLINE
					Class# 20863 meets 08/17/2020-10/15/2020				
					20865	12.0 HRS ARR	(OL)	Cooke,M	ONLINE
					Class# 20865 meets 08/17/2020-10/15/2020				
					27689	12.0 HRS ARR	(OL)	Alcala,S	ONLINE
					Class# 27689 meets 08/17/2020-10/15/2020				
<b>NRSRG 212 - 5.0 UNITS MEDICAL-SURGICAL NURSING I</b> Transferable to CSU Prerequisite: NRSRG 210 or equivalent with a grade of Pass or "C" or higher. For Option B students: Possession of an active Licensed Psychiatric Technician license and admission to the Nursing Program. Corequisite: NRSRG 211 may be taken prior to admission or concurrent. Recommendation: NRSRG 200 or NRSRG 213A or equivalent with a grade of Pass or "C" or higher.					<b>NRSRG 212</b> NOTE: a material fee of \$31.75 is required for NRSRG 212				
29073	+ 0.5 HRS ARR	(OL)	Gemmill,O	ONLINE	20911	+ 5.0 HRS ARR	(OL)	Veloz-Rendon,L	ONLINE
PLEASE ENROLL IN LAB SECTION OF YOUR CHOICE. THE LECTURE SECTION #29073 WILL BE AUTOMATICALLY ADDED.					PLEASE ENROLL IN LAB SECTION AS ASSIGNED. THE LECTURE SECTION #20860 WILL BE AUTOMATICALLY ADDED.				
Class# 29073 meets 10/21/2020-12/16/2020					Class# 20911 meets 10/19/2020-12/17/2020				
<b>29074</b>	<b>4:30- 7:45PM</b>	<b>W</b>	Gemmill,O	SL121	20912	15.0 HRS ARR	(OL)	Veloz-Rendon,L	ONLINE
Class# 29074 meets 10/21/2020-12/16/2020					Class# 20912 meets 10/19/2020-12/17/2020				
<b>30558</b>	<b>4:30-7:45PM</b>	<b>W</b>	STAFF	SL122	20913	15.0 HRS ARR	(OL)	STAFF	ONLINE
Class# 30558 meets 10/21/2020-12/16/2020					Class# 20913 meets 10/19/2020-12/17/2020				
<b>NRSRG 26 - 0.5 UNIT CLINICAL WORKSHOP 2</b> Not Transferable NOTE: a material fee of \$55.00 is required for NRSRG 26					<b>NRSRG 213A - 0.5 UNIT MAJOR DRUGS AND NURSING MANAGEMENT I</b> Transferable to CSU				
20859	+ 0.5 HRS ARR	(OL)	Gemmill,O	SL121	20866	9:00-10:15AM	Th	Brooks,K	REMOTE
PLEASE ENROLL IN LAB SECTION OF YOUR CHOICE. THE LECTURE SECTION #20859 WILL BE AUTOMATICALLY ADDED.					Class# 20866 meets 11/12/2020-12/17/2020				
Class# 20859 meets 10/21/2020-12/16/2020					<b>NRSRG 213B - 1.0 UNIT MAJOR DRUGS AND NURSING MANAGEMENT II</b> Transferable to CSU Prerequisite: NRSRG 213A or equivalent with a grade of Pass or "C" or higher.				
<b>21192</b>	<b>4:30- 7:45PM</b>	<b>W</b>	Gemmill,O	SL121	21404	4:00- 5:50PM	Th	Brooks,K	REMOTE
Class# 21192 meets 10/21/2020-12/16/2020					Class# 21404 meets 08/20/2020-10/15/2020				
<b>30559</b>	<b>4:30- 7:45PM</b>	<b>W</b>	STAFF	SL122	<b>NRSRG 215 - 1.0 UNIT ADVANCED PLACEMENT BRIDGE</b> Transferable to CSU Recommendation: Completion of READ 54, ENGL 52, and MATH 60 or equivalent with grades of Pass or "C" or higher or successful completion of the college placement process.				
Class# 30559 meets 10/21/2020-12/16/2020					22196	2.0 HRS ARR	(OL)	Riedel,P	ONLINE
Class# 30559 meets 10/21/2020-12/16/2020					Class# 22196 meets 10/19/2020-12/18/2020				
<b>NRSRG 48T - 0.5 UNIT ELECTIVE NURSING - TUTORIAL</b> Not Transferable					<b>NRSRG 220 - 5.5 UNITS MEDICAL-SURGICAL NURSING 3</b> Transferable to CSU Prerequisite: NRSRG 211, NRSRG 212 and NRSRG 213A or equivalent with a grade of "C" or higher or "Pass." For Option B and E students. NOTE: a material fee of \$51.25 is required for NRSRG 220				
29075	4.0 HRS ARR	(OL)	Riedel,P	ONLINE	20867	+ 6.0 HRS ARR	(OL)	Orozco,R	ONLINE
Class# 29075 meets 08/19/2020-10/14/2020					PLEASE ENROLL IN LAB SECTION AS ASSIGNED. THE LECTURE SECTION #20860 WILL BE AUTOMATICALLY ADDED.				
Class# 29075 meets 08/19/2020-10/14/2020					Class# 20867 meets 08/17/2020-10/15/2020				
<b>NRSRG 57LA - 1.0 UNIT BEGINNING NURSING SKILLS LAB</b> Not Transferable Corequisite: NRSRG 210 or NRSRG 212					Class# 20869 meets 08/17/2020-10/15/2020				
23691	3.0 HRS ARR	(OL)	Natividad,R	ONLINE	20870	15.0 HRS ARR	(OL)	Orozco,R	ONLINE
Class# 23691 meets 08/17/2020-12/18/2020					Class# 20870 meets 08/17/2020-10/15/2020				
<b>NRSRG 57LB - 1.0 UNIT INTERMEDIATE NURSING SKILLS LAB</b> Not Transferable Corequisite: NRSRG 220 or NRSRG 222					Class# 24202 meets 08/17/2020-10/15/2020				
23692	3.0 HRS ARR	(OL)	Natividad,R	ONLINE	<b>NRSRG 220</b> NOTE: a material fee of \$51.25 is required for NRSRG 220				
Class# 23692 meets 08/17/2020-12/18/2020					Class# 24202 meets 08/17/2020-10/15/2020				
<b>NRSRG 57LC - 1.0 UNIT ADVANCED INTERMEDIATE NURSING SKILLS LAB</b> Not Transferable Corequisite: NRSRG 230 or NRSRG 232					<b>NRSRG 220</b> NOTE: a material fee of \$51.25 is required for NRSRG 220				
23693	3.0 HRS ARR	(OL)	Gonzalez,K	ONLINE	20867	+ 6.0 HRS ARR	(OL)	Orozco,R	ONLINE
Class# 23693 meets 08/17/2020-12/18/2020					PLEASE ENROLL IN LAB SECTION AS ASSIGNED. THE LECTURE SECTION #20860 WILL BE AUTOMATICALLY ADDED.				
Class# 23693 meets 08/17/2020-12/18/2020					Class# 20867 meets 08/17/2020-10/15/2020				
<b>NRSRG 80 - 1.0 UNIT NURSING PROCESS DOCUMENTATION</b> Transferable to CSU Prerequisite: NRSRG 210 or equivalent with a grade of Pass or "C" or higher or admission to the Nursing Program.					Class# 20869 meets 08/17/2020-10/15/2020				
30560	2.0 HRS ARR	(OL)	STAFF	ONLINE	20870	15.0 HRS ARR	(OL)	Orozco,R	ONLINE
+ 1.0 HRS ARR (OL) STAFF ONLINE					Class# 20870 meets 08/17/2020-10/15/2020				
Class# 30560 meets 08/17/2020-10/16/2020					Class# 24202 meets 08/17/2020-10/15/2020				

If a class displays as **REMOTE** in the schedule, students will be expected to log into the class at a specified day/time (e.g., MW 8-9:15am). If the class displays as **ONLINE** in the schedule, students are permitted to log into the class whenever they are available to complete coursework by the established deadlines.

Students not in attendance or late for the first class meeting are subject to drop.

Class#	Time	Day	Instructor	Room	Class#	Time	Day	Instructor	Room
25520	15.0 HRS ARR	(OL)	Pison,T	ONLINE	<b>PHARMACY TECHNICIAN</b>				
Class# 25520 meets 08/17/2020-10/15/2020									
30059	15.0 HRS ARR	(OL)	Leonard,A	ONLINE					
<b>NRSR 222 - 5.5 UNITS MATERNAL/CHILD NURSING</b>									
Transferable to CSU									
Prerequisite: NRSR 220 or equivalent with a grade of Pass or "C" or higher.									
20916	+ 6.0 HRS ARR	(OL)	Orozco,R	ONLINE					
PLEASE ENROLL IN LAB SECTION AS ASSIGNED. THE LECTURE SECTION #20916 WILL BE AUTOMATICALLY ADDED.									
Class# 30059 meets 08/17/2020-10/15/2020									
20917	15.0 HRS ARR	(OL)	Castro,V	ONLINE					
Class# 20917 meets 10/19/2020-12/17/2020									
21641	15.0 HRS ARR	(OL)	Knapp,J	ONLINE					
Class# 21641 meets 10/19/2020-12/17/2020									
22146	15.0 HRS ARR	(OL)	Orozco,R	ONLINE					
Class# 22146 meets 10/19/2020-12/17/2020									
22358	15.0 HRS ARR	(OL)	Castro,V	ONLINE					
Class# 22358 meets 10/19/2020-12/17/2020									
24203	15.0 HRS ARR	(OL)	Cochran,M	ONLINE					
<b>NRSR 230 - 5.0 UNITS PSYCHOSOCIAL AND COMMUNITY NURSING</b>									
Transferable to CSU									
Prerequisite: NRSR 222 or equivalent with a grade of Pass or "C" or higher. For Option C, D, E and F students: Admission to the Nursing Program.									
20872	+ 6.0 HRS ARR	(OL)	Gonzalez,K	ONLINE					
PLEASE ENROLL IN LAB SECTION AS ASSIGNED. THE LECTURE SECTION #20872 WILL BE AUTOMATICALLY ADDED.									
Class# 24203 meets 10/19/2020-12/17/2020									
20873	12.0 HRS ARR	(OL)	Clement,J	ONLINE					
Class# 20873 meets 08/17/2020-10/15/2020									
20874	12.0 HRS ARR	(OL)	Yannitelli,K	ONLINE					
Class# 20874 meets 08/17/2020-10/15/2020									
20875	12.0 HRS ARR	(OL)	Caminiti,C	ONLINE					
Class# 20875 meets 08/17/2020-10/15/2020									
20876	12.0 HRS ARR	(OL)	Intalapitagsa,A	ONLINE					
Class# 20876 meets 08/17/2020-10/15/2020									
20877	12.0 HRS ARR	(OL)	Gonzalez,K	ONLINE					
Class# 20877 meets 08/17/2020-10/15/2020									
30391	12.0 HRS ARR	(OL)	Baldwin,M	ONLINE					
<b>NRSR 232 - 5.0 UNITS MEDICAL-SURGICAL NURSING 4</b>									
Transferable to CSU									
Prerequisite: NRSR 230 or equivalent with a grade of Pass or "C" or higher. For Option C, D, and E students: Admission to the Nursing Program.									
NOTE: a material fee of \$82.00 is required for NRSR 232									
20918	+ 5.0 HRS ARR	(OL)	Brooks,K	ONLINE					
PLEASE ENROLL IN LAB SECTION AS ASSIGNED. THE LECTURE SECTION #20918 WILL BE AUTOMATICALLY ADDED.									
Class# 30391 meets 08/17/2020-10/15/2020									
20919	15.0 HRS ARR	(OL)	Robbins II,H	ONLINE					
Class# 20919 meets 10/19/2020-12/18/2020									
20920	15.0 HRS ARR	(OL)	Brown Farr,N	ONLINE					
Class# 20920 meets 10/19/2020-12/18/2020									
20921	15.0 HRS ARR	(OL)	STAFF	ONLINE					
Class# 20921 meets 10/19/2020-12/18/2020									
20922	15.0 HRS ARR	(OL)	Caminiti,C	ONLINE					
Class# 20922 meets 10/19/2020-12/18/2020									
20923	15.0 HRS ARR	(OL)	Moreno,J	ONLINE					
<b>NRSR 251 - 1.0 UNIT BASIC ADULT PHYSICAL ASSESSMENT</b>									
Transferable to CSU									
NOTE: a material fee of \$7.00 is required for NRSR 251									
21405	+ 1.0 HRS ARR	(OL)	Caminiti,C	ONLINE					
PLEASE ENROLL IN LAB SECTION OF YOUR CHOICE. THE LECTURE SECTION #21405 WILL BE AUTOMATICALLY ADDED.									
Class# 20923 meets 10/19/2020-12/18/2020									
21406	3.0 HRS ARR	(OL)	Caminiti,C	ONLINE					
Class# 21406 meets 08/17/2020-10/16/2020									
30562	3.0 HRS ARR	(OL)	STAFF	ONLINE					
					<p>Students who wish to complete the program at an accelerated pace must make an appointment with the program director by calling (562) 860-2451, ext. 2562. Clearance of a criminal background check and/or drugs of abuse testing may be required prior to clinical field experience</p>				
					<b>PHAR 50 - 1.5 UNITS PHARMACEUTICS</b>				
					Not Transferable				
					Prerequisite: HO 56 or equivalent with a grade of Pass or "C" or higher.				
20952	8:00-10:50AM	W	Makarem,N	REMOTE					
					Class# 20952 meets 10/21/2020-12/16/2020				
					<b>PHAR 55 - 1.5 UNITS PHARMACY INTRODUCTION</b>				
					Not Transferable				
					Corequisite: PHAR 56				
23662	8:00-10:50AM	T	Makarem,N	REMOTE					
					Class# 23662 meets 08/18/2020-10/13/2020				
					<b>PHAR 56 - 0.5 UNIT PHARMACY SKILLS LAB INTRODUCTION</b>				
					Not Transferable				
					Corequisite: PHAR 55				
					NOTE: a material fee of \$10.00 is required for PHAR 56				
23665	+ 1.0 HRS ARR	(OL)	Shields,J	ONLINE					
					PLEASE ENROLL IN LAB SECTION OF YOUR CHOICE. THE LECTURE SECTION #23665 WILL BE AUTOMATICALLY ADDED.				
					Class# 23665 meets 08/18/2020-10/13/2020				
23666	11:00-12:50PM	T	Shields,J	SL101					
					Class# 23666 meets 08/18/2020-10/13/2020				
30563	1:00-2:50PM	T	Shields,J	SL101					
					Class# 30563 meets 08/18/2020-10/13/2020				
					<b>PHAR 57 - 1.5 UNITS PHARMACY OPERATIONS I</b>				
					Not Transferable				
23669	8:00-10:50AM	F	Makarem,N	REMOTE					
					Class# 23669 meets 08/21/2020-10/16/2020				
					<b>PHAR 63 - 2.0 UNITS PHARMACY OPERATIONS II</b>				
					Not Transferable				
					Prerequisite: PHAR 55, PHAR 56, and PHAR 57 or equivalent with grades of Pass or "C" or higher.				
					NOTE: a material fee of \$15.00 is required for PHAR 63				
20772	+ 4.0 HRS ARR	(OL)	Shields,J	ONLINE					
					PLEASE ENROLL IN LAB SECTION OF YOUR CHOICE. THE LECTURE SECTION #20772 WILL BE AUTOMATICALLY ADDED.				
					Class# 20772 meets 10/20/2020-12/15/2020				
21173	8:00- 9:50AM	T	Shields,J	SL101					
					Class# 21173 meets 10/20/2020-12/15/2020				
30565	10:00-11:50AM	T	Shields,J	SL101					
					<b>PHAR 64 - 2.0 UNITS PHARMACY OPERATIONS III</b>				
					Not Transferable				
					Prerequisite: PHAR 50, PHAR 55, PHAR 56, PHAR 57, and PHAR 63 or equivalents with grades of Pass or "C" or higher. PHAR 63 may be taken concurrently with PHAR 64; however PHAR 64 cannot be taken prior to PHAR 63. NOTE: a material fee of \$45.00 is required for PHAR 64				
23557	+ 2.0 HRS ARR	(OL)	Shields,J	ONLINE					
					PLEASE ENROLL IN LAB SECTION OF YOUR CHOICE. THE LECTURE SECTION #23557 WILL BE AUTOMATICALLY ADDED.				
23558	9:00- 9:50AM	F	Shields,J	SL101					
30567	10:00-10:50AM	F	Shields,J	SL101					
30568	11:00-11:50AM	F	Shields,J	SL101					
					<b>PHAR 65 - 2.0 UNITS PHARMACY OPERATIONS IV - NON-STERILE COMPOUNDING</b>				
					Not Transferable				
					Prerequisite: PHAR 50 and PHAR 63 or equivalent with grades of Pass or "C" or higher. NOTE: a material fee of \$45.00 is required for PHAR 65				
22144	8:00- 9:50AM	W	Casas,R	REMOTE					
					PLEASE ENROLL IN LAB SECTION OF YOUR CHOICE. THE LECTURE SECTION #22144 WILL BE AUTOMATICALLY ADDED.				
22145	11:00-11:50AM	W	Casas,R	SL101					
30569	12:30- 1:20PM	W	Casas,R	SL101					
30570	1:30- 1:50PM	W	Casas,R	SL101					

If a class displays as **REMOTE** in the schedule, students will be expected to log into the class at a specified day/time (e.g., MW 8-9:15am). If the class displays as **ONLINE** in the schedule, students are permitted to log into the class whenever they are available to complete coursework by the established deadlines.

Students not in attendance or late for the first class meeting are subject to drop.

Class#	Time	Day	Instructor	Room	Class#	Time	Day	Instructor	Room
<b>PHAR 81 - 3.0 UNITS OVER-THE-COUNTER PRODUCTS</b>					26554	3.0 HRS ARR	(OL)	Chatman,T	ONLINE
Not Transferable					28375	3.0 HRS ARR	(OL)	Mittendorf,R	ONLINE
Recommendation: MA 161 or A&P 120 or equivalent with a grade of Pass or "C" or higher.					29126	3.0 HRS ARR	(OL)	Mittendorf,R	ONLINE
20773	8:00-10:50AM	Th	Casas,R	REMOTE	29450	12:30- 1:45PM	TTh	Swearingin,R	REMOTE
Class# 30565 meets 10/20/2020-12/15/2020					<b>PHIL 104 - 3.0 UNITS PHILOSOPHY OF CULTURAL DIVERSITY: CHALLENGE AND CHANGE</b>				
<b>PHAR 83 - 3.0 UNITS PHARMACY TECHNICIAN PHARMACOLOGY I</b>					Transferable to UC, CSU				
Not Transferable					Prerequisite: ENGL 52 or ENGL 72 or ESL 152 or equivalent with a grade of "C" or higher or "Pass" or completion of the English Placement Process with eligibility for ENGL 100 or ENGL 100S.				
Prerequisite: MA 161 or A&P 120 or equivalent with a grade of Pass or "C" or higher.					21422	3.0 HRS ARR	(OL)	Stolze,T	ONLINE
20467	8:00-10:50AM	T	Casas,R	REMOTE	20474	3.0 HRS ARR	(OL)	Mayock,M	ONLINE
<b>PHAR 85 - 3.0 UNITS PHARMACY TECHNICIAN PHARMACOLOGY II</b>					Note: For class information and orientation go to Canvas.				
Not Transferable					26382	3.0 HRS ARR	(OL)	Mittendorf,R	ONLINE
Prerequisite: MA 161 or A&P 120 or equivalent with a grade of Pass or "C" or higher.					29568	3.0 HRS ARR	(OL)	Mayock,M	ONLINE
20774	3.0 HRS ARR	(OL)	Makarem,N	ONLINE	Note: For class information and orientation go to Canvas.				
<b>PHAR 90 - 3.5 UNITS CLINICAL EXPERIENCE I</b>					<b>PHIL 106 - 3.0 UNITS INTRODUCTION TO LOGIC</b>				
Not Transferable					Transferable to UC, CSU (CAN PHIL 6)				
Prerequisite: PHAR 50, PHAR 63, PHAR 65, and PHAR 81 or equivalents with grades of "C" or higher or "Pass".					Prerequisite: ENGL 100 or ENGL 100S or equivalent with a grade of "C" or higher or "Pass".				
20468	9:00- 9:50AM	Th	Makarem,N	REMOTE	20778	3.0 HRS ARR	(OL)	Van De Mortel,J	ONLINE
+ 6.7 HRS ARR					TBD *				
<b>PHAR 95 - 5.0 UNITS CLINICAL EXPERIENCE II</b>					<b>PHIL 130 - 3.0 UNITS HISTORY OF ANCIENT PHILOSOPHY</b>				
Not Transferable					Transferable to UC, CSU				
Prerequisite: PHAR 64, PHAR 83, and PHAR 85 or equivalent with grades of Pass or "C" or higher.					Prerequisite: ENGL 52 or ENGL 72 or ESL 152 or equivalent with a grade of "C" or higher or "Pass" or completion of the assessment/placement process with eligibility for ENGL 100 or ENGL 100S.				
NOTE: a material fee of \$10.00 is required for PHAR 95					27009	3.0 HRS ARR	(OL)	Van De Mortel,J	ONLINE
20469	8:00- 8:50AM	Th	Casas,R	REMOTE	<b>PHIL 160 - 3.0 UNITS SYMBOLIC LOGIC</b>				
+11.1 HRS ARR					Transferable to UC, CSU				
Casas,R					Prerequisite: ENGL 100 or ENGL 100S or equivalent with a grade of "C" or higher or "Pass".				
Casas,R					Recommendation: PHIL 106 with a grade of "C" or higher or "Pass".				
TBD *					29451	11:00-12:30PM	TTh	Swearingin,R	REMOTE
					Class# 29451 meets 09/08/2020-12/17/2020				
<b>PHILOSOPHY</b>									
<b>PHIL 100 - 3.0 UNITS INTRODUCTION TO PHILOSOPHY</b>					<b>PHIL 200 - 3.0 UNITS WORLD RELIGIONS</b>				
Transferable to UC, CSU (CAN PHIL 2)					Transferable to UC, CSU				
Prerequisite: ENGL 52 or ENGL 72 or ESL 152 or equivalent with a grade of "C" or higher or "Pass", or completion of the English assessment/placement process with eligibility for ENGL 100 or ENGL 100S.					Recommendation: Satisfactory completion of the English Placement Process or ENGL 52 or ENGL 155 or equivalent with a grade of Pass or "C" or higher is strongly recommended.				
22579	3.0 HRS ARR	(OL)	Stolze,T	ONLINE	20779	3.0 HRS ARR	(OL)	Van De Mortel,J	ONLINE
20470	3.0 HRS ARR	(OL)	Mittendorf,R	ONLINE	<b>PHIL 203 - 3.0 UNITS PHILOSOPHY OF RELIGION</b>				
24058	3.0 HRS ARR	(OL)	Van De Mortel,J	ONLINE	Transferable to UC, CSU				
20775	3.0 HRS ARR	(OL)	Spooner,G	ONLINE	Prerequisite: ENGL 52 or ENGL 72 or ESL 152 or equivalent with a grade of "C" or higher or "Pass", or completion of the English assessment/placement process with eligibility for ENGL 100 or ENGL 100S.				
20776	3.0 HRS ARR	(OL)	Stolze,T	ONLINE	22885	3.0 HRS ARR	(OL)	Stolze,T	ONLINE
29275	3.0 HRS ARR	(OL)	Sliff,R	ONLINE	<b>PHIL 205 - 3.0 UNITS INTRODUCTION TO BIOETHICS</b>				
23785	3.6 HRS ARR	(OL)	Pereira,J	ONLINE	Transferable to UC, CSU				
Class# 23785 meets 09/08/2020-12/18/2020					Prerequisite: ENGL 52 ENGL 72 ESL 152 or equivalent with a grade of "C" or higher or "Pass" or completion of the English Placement Process with eligibility for ENGL 100 or ENGL 100S.				
20472	7:00-10:20PM	T	Deering,M	REMOTE	30491				
Class# 20472 meets 09/08/2020-12/15/2020					3.0 HRS ARR				
27746	7:00-10:30PM	Th	Deering,M	REMOTE	(OL)				
Class# 27746 meets 09/10/2020-12/17/2020					Stolze,T				
					ONLINE				
					Note: All class information will be available in Canvas.				
<b>PHIL 102 - 3.0 UNITS INTRODUCTION TO ETHICS</b>					<b>PHOTOGRAPHY</b>				
Transferable to UC, CSU (CAN PHIL 4)					<b>PHOT 100 - 3.0 UNITS INTRODUCTORY PHOTOGRAPHY</b>				
Prerequisite: ENGL 52 or ENGL 72 or ESL 152 or equivalent with a grade of "C" or higher or "Pass", or completion of the English assessment/placement process with eligibility for ENGL 100 or ENGL 100S.					Transferable to UC, CSU (CAN ART 18)				
21603	3.0 HRS ARR	(OL)	Van De Mortel,J	ONLINE	NOTE: a material fee of \$20.00 is required for PHOT 100				
21421	7:00-9:50PM	W	Cho,Y	REMOTE	20478	9:00-10:00AM	TTh	Emmett,K	REMOTE
28033	3.0 HRS ARR	(OL)	Sutherland,C	ONLINE	10:00-11:50AM				
Note: For class information and orientation go to Canvas.					TTh				
28034	3.0 HRS ARR	(OL)	Sutherland,C	ONLINE	Emmett,K				
Note: For class information and orientation go to Canvas.					Emmett,K				
					Students need to have a manually operable digital camera for the course.				
					Students are required to complete one assignment in the fine arts facility with specific times arranged with the faculty member.				
					Note: Students need to have a manually operable digital camera for the course, access to internet, a computer and Adobe Photoshop and Bridge software.				
					Students are required to complete one assignment in the Fine Arts Facility with specific times arranged with the faculty member.				
<b>PHIL 103 - 3.0 UNITS PHILOSOPHICAL REASONING: CRITICAL THINKING IN PHILOSOPHY</b>									
Transferable to UC, CSU									
Prerequisite: ENGL 100 or ENGL 100S or equivalent with a grade of "C" or higher or "Pass" or satisfactory completion of the Advanced Placement English Examination of the College Entrance Examination Board.									
21783	3.0 HRS ARR	(OL)	Mittendorf,R	ONLINE					
21782	3.0 HRS ARR	(OL)	Chatman,T	ONLINE					
21784	3.0 HRS ARR	(OL)	Spooner,G	ONLINE					

If a class displays as **REMOTE** in the schedule, students will be expected to log into the class at a specified day/time (e.g., MW 8-9:15am). If the class displays as **ONLINE** in the schedule, students are permitted to log into the class whenever they are available to complete coursework by the established deadlines.

Students not in attendance or late for the first class meeting are subject to drop.

Class#	Time	Day	Instructor	Room	Class#	Time	Day	Instructor	Room
20479	12:30- 1:30PM 1:30- 3:20PM	MW MW	Flanders,M Flanders,M	REMOTE REMOTE	<b>PHYSICAL EDUCATION</b>				
Note: Students need to have a manually operable digital camera for the course, access to internet, a computer and Adobe Photoshop and Bridge software. Students are required to complete one assignment in the Fine Arts Facility with specific times arranged with the faculty member.									
20780	9:00-10:00AM 10:00-11:50AM	MW MW	Ortiz,A Ortiz,A	REMOTE REMOTE					
Note: Students need to have a manually operable digital camera for the course, access to internet, a computer and Adobe Photoshop and Bridge software. Students are required to complete one assignment in the Fine Arts Facility with specific times arranged with the faculty member.									
24012	12:30- 1:30PM 1:30- 3:20PM	TTh TTh	Sanchez,A Sanchez,A	REMOTE REMOTE					
Note: Students need to have a manually operable digital camera for the course, access to internet, a computer and Adobe Photoshop and Bridge software. Students are required to complete one assignment in the Fine Arts Facility with specific times arranged with the faculty member.									
<b>PHOT 110 - 3.0 UNITS INTRODUCTION TO DIGITAL PHOTOGRAPHY</b>									
Transferable to CSU									
NOTE: a material fee of \$12.50 is required for PHOT 110									
20480	2.0 HRS ARR + 4.0 HRS ARR	(OL) (OL)	Fernandez,C Fernandez,C	ONLINE ONLINE					
Note: Students need to have a manually operable digital camera for the course, access to internet, a computer and Adobe Photoshop and Bridge software.									
24040	2.0 HRS ARR + 4.0 HRS ARR	(OL) (OL)	Heckerman,E Heckerman,E	ONLINE ONLINE					
Note: Students need to have a manually operable digital camera for the course, access to internet, a computer and Adobe Photoshop and Bridge software.									
30587	2.0 HRS ARR + 4.0 HRS ARR	(OL) (OL)	Fernandez,C Fernandez,C	ONLINE ONLINE					
Note: Students need to have a manually operable digital camera for the course, access to internet, a computer and Adobe Photoshop and Bridge software.									
30589	2.0 HRS ARR + 4.0 HRS ARR	(OL) (OL)	Heckerman,E Heckerman,E	ONLINE ONLINE					
Note: Students need to have a manually operable digital camera for the course, access to internet, a computer and Adobe Photoshop and Bridge software.									
<b>PHOT 112 - 3.0 UNITS INTERMEDIATE DIGITAL PHOTOGRAPHY</b>									
Transferable to CSU									
Prerequisite: PHOT 110 or ART 192 or equivalent with a grade of Pass or "C" or higher.									
NOTE: a material fee of \$10.00 is required for PHOT 112									
26850	2.0 HRS ARR + 4.0 HRS ARR	(OL) (OL)	Fernandez,C Fernandez,C	ONLINE ONLINE					
Note: Students need to have a manually operable digital camera for the course, access to internet, a computer and Adobe Photoshop and Bridge software.									
30591	2.0 HRS ARR + 4.0 HRS ARR	(OL) (OL)	Fernandez,C Fernandez,C	ONLINE ONLINE					
Note: Students need to have a manually operable digital camera for the course, access to internet, a computer and Adobe Photoshop and Bridge software.									
<b>PHOT 122 - 3.0 UNITS COLOR PHOTOGRAPHY</b>									
Transferable to CSU									
Prerequisite: PHOT 100 or PHOT 110 or equivalent with a grade of Credit or "C" or higher.									
NOTE: a material fee of \$20.00 is required for PHOT 122									
30643	2.0 HRS ARR + 4.0 HRS ARR	(OL) (OL)	Heckerman,E Heckerman,E	ONLINE ONLINE					
<b>PHOT 130 - 3.0 UNITS PHOTO JOURNALISM</b>									
Transferable to CSU									
Recommendation: PHOT 100 or equivalent with a grade of Pass or "C" or higher.									
30324	3.0 HRS ARR	(OL)	Fernandez,C	ONLINE					
<b>PHOT 150 - 3.0 UNITS PHOTOGRAPHY AND SOCIETY</b>									
Transferable to UC, CSU									
29081	3.0 HRS ARR	(OL)	Fernandez,C	ONLINE					
<b>PHOT 160 - 3.0 UNITS HISTORY OF PHOTOGRAPHY</b>									
Transferable to UC, CSU									
25550	3.0 HRS ARR	(OL)	Schwenkmeyer,K	ONLINE					
29300	12:00-12:15PM 12:15-12:50PM	MW MW	O'Connor,J O'Connor,J	REMOTE REMOTE					
30412	1:30- 2:00PM 2:00- 3:20PM	TTh TTh	STAFF STAFF	REMOTE REMOTE					
Class# 30412 meets 08/18/2020-10/15/2020									
29302	1:30- 2:00PM 2:00- 3:20PM	TTh TTh	O'Connor,J O'Connor,J	REMOTE REMOTE					
Class# 29302 meets 10/20/2020-12/17/2020									
<b>PEX 100A - 1.0 UNIT ADAPTED INDEPENDENT EXERCISE</b>									
Transferable to UC, CSU									
28183	9:30- 9:45AM 9:45-10:20AM	TTh TTh	STAFF STAFF	REMOTE REMOTE					
28185	12:00-12:15PM 12:15-12:50PM	MW MW	O'Connor,J O'Connor,J	REMOTE REMOTE					
<b>PEX 101 - 1.0 UNIT WHEELCHAIR ACTIVITIES</b>									
Transferable to UC, CSU									
Recommendation: Completed adapted physical education physician health clearance for participation, adapted physical education health history questionnaire, intake interview assessment procedures.									
28512	10:00-10:15AM 10:15-10:50AM	TTh TTh	O'Connor,J O'Connor,J	REMOTE REMOTE					
<b>PEX 102 - 1.0 UNIT ADAPTED CARDIOVASCULAR EXERCISES</b>									
Transferable to UC, CSU									
Recommendation: Completed adapted physical education physician health clearance for participation, adapted physical education health history questionnaire, intake interview assessment procedures.									
27132	12:30-12:45PM 12:45- 1:20PM	TTh TTh	O'Connor,J O'Connor,J	REMOTE REMOTE					
28000	12:00-12:15PM 12:15-12:50PM	MW MW	O'Connor,J O'Connor,J	REMOTE REMOTE					
30414	9:30- 9:45AM 9:45-10:20AM	MW MW	O'Connor,J O'Connor,J	REMOTE REMOTE					
30416	1:30- 2:00PM 2:00- 3:20PM	TTh TTh	Lim,J Lim,J	REMOTE REMOTE					
Class# 30416 meets 08/18/2020-10/15/2020									
<b>PEX 103 - 1.0 UNIT ADAPTED STRENGTH TRAINING</b>									
Transferable to CSU									
Recommendation: Completed adapted physical education physician health clearance for participation, adapted physical education health history questionnaire, intake interview assessment procedures.									
30418	9:30- 9:45AM 9:45-10:20AM	MW MW	O'Connor,J O'Connor,J	REMOTE REMOTE					
24724	1:00- 1:30PM 1:30- 1:50PM	MW MW	O'Connor,J O'Connor,J	REMOTE REMOTE					
<b>PEX 103A - 1.0 UNIT ADAPTED CIRCUIT WEIGHT TRAINING</b>									
Transferable to UC, CSU									
28201	1:00- 1:30PM 1:30- 1:50PM	MW MW	O'Connor,J O'Connor,J	REMOTE REMOTE					
29306	9:30- 9:45AM 9:45-10:20AM	TTh TTh	Lim,J Lim,J	REMOTE REMOTE					
29308	12:30-12:45PM 12:45- 1:20PM	TTh TTh	O'Connor,J O'Connor,J	REMOTE REMOTE					
<b>PEX 104 - 1.0 UNIT ADAPTED STRETCHING AND RELAXATION</b>									
Transferable to UC, CSU									
Recommendation: Completed adapted physical education physician health clearance for participation, adapted physical education health history questionnaire, intake interview assessment procedures.									
29310	12:30-12:45PM 12:45- 1:20PM	TTh TTh	O'Connor,J O'Connor,J	REMOTE REMOTE					
30420	9:30- 9:45AM 9:45-10:20AM	MW MW	O'Connor,J O'Connor,J	REMOTE REMOTE					
24726	1:30- 2:00PM 2:00- 3:20PM	TTh TTh	O'Connor,J O'Connor,J	REMOTE REMOTE					
Class# 24726 meets 10/20/2020-12/17/2020									

If a class displays as **REMOTE** in the schedule, students will be expected to log into the class at a specified day/time (e.g., MW 8-9:15am). If the class displays as **ONLINE** in the schedule, students are permitted to log into the class whenever they are available to complete coursework by the established deadlines.

Students not in attendance or late for the first class meeting are subject to drop.

Class#	Time	Day	Instructor	Room	Class#	Time	Day	Instructor	Room
<b>PEX 104D - 2.0 UNITS INTRODUCTION TO ADAPTIVE DANCE</b>					30273	8:00- 8:30AM	MW	STAFF	REMOTE
Transferable to UC, CSU						8:30- 9:30AM	MW	STAFF	REMOTE
30422	9:00- 9:30AM	MW	Horner,B	REMOTE	Class# 30273 meets 09/09/2020-12/16/2020				
	9:30-10:50AM	MW	Horner,B	REMOTE					
<b>PEX 105 - 1.0 UNIT ADAPTED SWIMMING</b>					<b>PEX 124 - 1.0 UNIT PERSONAL FITNESS PROGRAM</b>				
Transferable to UC, CSU					Transferable to UC, CSU				
Recommendation: Completed adapted physical education physician					30277	6:00- 6:15PM	TTh	Velazquez-Ortega,M	REMOTE
health clearance for participation, adapted physical education health history						6:15- 6:50PM	TTh	Velazquez-Ortega,M	REMOTE
questionnaire, intake interview assessment procedures.					24758	0.5 HRS ARR	(OL)	Edwards,C	ONLINE
						+ 1.5 HRS ARR	(OL)	Edwards,C	ONLINE
25559	1:30- 2:00PM	TTh	O'Connor,J	REMOTE	24762	2:00- 2:15PM	MW	Wikert Hoag,R	REMOTE
	2:00- 3:20PM	TTh	O'Connor,J	REMOTE		2:15- 2:50PM	MW	Wikert Hoag,R	REMOTE
Class# 25559 meets 08/18/2020-10/15/2020					24764	9:30- 9:45AM	TTh	Kozlowski,T	REMOTE
						9:45-10:20AM	TTh	Kozlowski,T	REMOTE
					30279	9:30- 9:45AM	MW	Kozlowski,T	REMOTE
						9:45-10:20AM	MW	Kozlowski,T	REMOTE
					26256	8:30- 8:45AM	TTh	O'Connor,J	REMOTE
						8:35- 9:25AM	TTh	O'Connor,J	REMOTE
					Class# 26256 meets 09/08/2020-12/17/2020				
29312	2:00- 2:30PM	MW	O'Connor,J	REMOTE	26480	4:00- 4:30PM	MW	STAFF	REMOTE
	2:30- 3:50PM	MW	O'Connor,J	REMOTE	<b>4:30- 5:50PM MW STAFF</b>				
Class# 29312 meets 08/17/2020-10/14/2020					Class# 26480 meets 10/19/2020-12/06/2020				
<b>PEX 106 - 1.0 UNIT ADAPTED AQUATIC EXERCISE</b>					<b>PEX 126 - 1.5 UNITS PHYSICAL FITNESS TRAINING</b>				
Transferable to UC, CSU					Transferable to UC, CSU				
Recommendation: Completed adapted physical education physician					24981	1:00- 1:15PM	MWF	Caines,T	REMOTE
health clearance for participation, adapted physical education health history						1:15- 1:50PM	MWF	Caines,T	REMOTE
questionnaire, intake interview assessment procedures.					24989	1:00- 1:15PM	MWF	Grosfeld,S	REMOTE
						1:15- 1:50PM	MWF	Grosfeld,S	REMOTE
29312	2:00- 2:30PM	MW	O'Connor,J	REMOTE					
	2:30- 3:50PM	MW	O'Connor,J	REMOTE					
Class# 29312 meets 08/17/2020-10/14/2020									
<b>PEX 106A - 1.0 UNIT ADAPTED AQUATIC GROUP FITNESS</b>					<b>PEX 130 - 1.0 UNIT WEIGHT MANAGEMENT</b>				
Transferable to UC, CSU					Transferable to UC, CSU				
29660	1:30- 2:00PM	TTh	O'Connor,J	REMOTE	25064	8:15- 8:35AM	TTh	O'Connor,J	REMOTE
	2:00- 3:20PM	TTh	O'Connor,J	REMOTE		8:35- 9:25AM	TTh	O'Connor,J	REMOTE
Class# 29660 meets 08/18/2020-10/15/2020					Class# 25064 meets 09/08/2020-12/17/2020				
<b>PEX 107 - 1.0 UNIT ADAPTED TEAM SPORTS</b>					<b>PEX 132 - 1.0 UNIT INDOOR CYCLING</b>				
Transferable to CSU					Transferable to UC, CSU				
Recommendation: Completed adapted physical education physician					30281	0.5 HRS ARR	(OL)	Bos,K	ONLINE
health clearance for participation, adapted physical education health history						+ 1.5 HRS ARR	(OL)	Bos,K	ONLINE
questionnaire, intake interview assessment procedures.					30283	0.5 HRS ARR	(OL)	Bos,K	ONLINE
						+ 1.5 HRS ARR	(OL)	Bos,K	ONLINE
30424	10:00-10:15AM	TTh	O'Connor,J	REMOTE					
	10:15-10:50AM	TTh	O'Connor,J	REMOTE					
<b>PEX 107A - 1.0 UNIT ADAPTED SOCCER</b>					<b>PEX 134 - 1.0 UNIT BODY SCULPTING</b>				
Transferable to UC, CSU					Transferable to UC, CSU				
29672	12:00-12:15PM	TTh	Lim,J	REMOTE	30285	8:30- 8:45AM	TTh	STAFF	REMOTE
	12:15-12:50PM	TTh	Lim,J	REMOTE		8:45- 9:20AM	TTh	STAFF	REMOTE
					26258	9:00- 9:30AM	F	STAFF	REMOTE
						9:30-10:50AM	F	STAFF	REMOTE
<b>PEX 109 - 1.0 UNIT ADAPTED GROUP FITNESS</b>					<b>PEX 135 - 1.5 UNITS ROPES, BANDS, AND SUSPENSION TRAINING</b>				
Transferable to UC, CSU					Transferable to UC, CSU				
30426	11:00-11:15AM	TTh	Lim,J	REMOTE	30287	2:00- 2:20PM	MW	STAFF	REMOTE
	11:15-11:50AM	TTh	Lim,J	REMOTE		2:20- 3:15PM	MW	STAFF	REMOTE
					Class# 30287 meets 09/09/2020-12/16/2020				
<b>PEX 113 - 1.0 UNIT ZUMBA</b>					<b>PEX 136 - 1.0 UNIT STRETCHING AND RELAXATION</b>				
Transferable to UC, CSU					Transferable to UC, CSU				
30265	11:00-11:15AM	TTh	Ibarguen Allpas,V	REMOTE	30428	12:00-12:30PM	F	STAFF	REMOTE
	11:15-11:50AM	TTh	Ibarguen Allpas,V	REMOTE		12:30- 1:50PM	F	STAFF	REMOTE
<b>PEX 119 - 1.0 UNIT BASIC TRAINING AND PHYSICAL CONDITIONING</b>					<b>PEX 137 - 1.0 UNIT CARDIO BARRE CONDITIONING</b>				
Transferable to UC, CSU					Transferable to UC, CSU				
25561	2:00- 2:15PM	MW	Caines,T	REMOTE	30291	5:30- 5:45PM	TTh	Hathaway,R	REMOTE
	2:15- 2:50PM	MW	Caines,T	REMOTE		5:45- 6:20PM	TTh	Hathaway,R	REMOTE
25563	2:00- 2:15PM	MW	Grosfeld,S	REMOTE	<b>PEX 138 - 1.0 UNIT WALKING FOR FITNESS</b>				
	2:15- 2:50PM	MW	Grosfeld,S	REMOTE	Transferable to UC, CSU				
<b>PEX 120 - 1.5 UNITS CARDIO KICKBOXING</b>					<b>PEX 139 - 1.0 UNIT WALKING/JOGGING FOR FITNESS</b>				
Transferable to UC, CSU					Transferable to CSU				
30267	1.0 HRS ARR	(OL)	Bos,K	ONLINE	25571	8:00- 8:15AM	MW	STAFF	REMOTE
	+ 2.0 HRS ARR	(OL)	Bos,K	ONLINE		8:15- 8:50AM	TTh	STAFF	REMOTE
<b>PEX 121 - 1.0 UNIT HIGH-INTENSITY INTERVAL TRAINING</b>					<b>PEX 139 - 1.0 UNIT WALKING/JOGGING FOR FITNESS</b>				
Transferable to UC, CSU					Transferable to CSU				
Recommendation: Students should be able to participate safely in a high-intensity					27160	8:00- 8:15AM	MW	STAFF	REMOTE
exercise program.						8:15- 8:50AM	MW	STAFF	REMOTE
30271	3:00- 3:15PM	TTh	Kozlowski,T	REMOTE					
	3:15- 3:50PM	TTh	Kozlowski,T	REMOTE					
30269	0.6 HRS ARR	(OL)	STAFF	ONLINE					
	+ 1.8 HRS ARR	(OL)	Bos,K	ONLINE					
Class# 30269 meets 09/08/2020-12/18/2020									
<b>PEX 122 - 1.5 UNITS CROSS FIT TRAINING AND FUNCTIONAL EXERCISES</b>									
Transferable to UC, CSU									
30275	4:00- 4:30PM	TTh	Velazquez-Ortega,M	REMOTE					
	B4:30- 5:15PM	TTh	Velazquez-Ortega,M	REMOTE					

If a class displays as **REMOTE** in the schedule, students will be expected to log into the class at a specified day/time (e.g., MW 8-9:15am). If the class displays as **ONLINE** in the schedule, students are permitted to log into the class whenever they are available to complete coursework by the established deadlines.

Students not in attendance or late for the first class meeting are subject to drop.

Class#	Time	Day	Instructor	Room	Class#	Time	Day	Instructor	Room
<b>PEX 140 - 1.0 UNIT JOGGING, BASICS</b>									
Transferable to UC, CSU									
24787	8:00- 8:15AM	MW	STAFF	REMOTE	28002	0.5 HRS ARR	(OL)	Chan,J	ONLINE
	8:15- 8:50AM	MW	STAFF	REMOTE		+ 1.5 HRS ARR	(OL)	Chan,J	ONLINE
					24835	1:00- 1:30PM	Sun	Christou,D	REMOTE
						1:30- 3:20PM	Sun	Christou,D	REMOTE
					Class# 24835 meets 08/23/2020-12/06/2020				
<b>PEX 141 - 1.0 UNIT JOGGING FOR FITNESS, BEGINNING</b>					<b>PEX 152 - 1.0 UNIT GENTLE YOGA</b>				
Transferable to UC, CSU					Transferable to UC, CSU				
24791	8:00- 8:15AM	MW	STAFF	REMOTE	26266	0.5 HRS ARR	(OL)	Hammond,J	ONLINE
	8:15- 8:50AM	MW	STAFF	REMOTE		+ 1.5 HRS ARR	(OL)	Hammond,J	ONLINE
<b>PEX 142 - 1.0 UNIT GROUP TREADMILL AND CARDIO MACHINE TRAINING</b>					27095 0.5 HRS ARR (OL) Hammond,J ONLINE				
Transferable to UC, CSU					+ 1.5 HRS ARR (OL) Hammond,J ONLINE				
30292	1:30- 1:50PM	TTh	STAFF	REMOTE	27097	2:00- 2:30PM	T	STAFF	REMOTE
	1:50- 2:40PM	TTh	STAFF	REMOTE		2:30- 3:50PM	T	STAFF	REMOTE
Class# 30292 meets 09/08/2020-12/17/2020					27099 0.5 HRS ARR (OL) Fritzler,A ONLINE				
					+ 1.5 HRS ARR (OL) Fritzler,A ONLINE				
<b>PEX 145 - 1.0 UNIT CIRCUIT WEIGHT TRAINING, BEGINNING</b>					<b>27722 7:30- 8:00PM T</b>				
Transferable to UC, CSU					Christou,D REMOTE				
24797	0.5 HRS ARR	(OL)	May,R	ONLINE	<b>8:00- 9:20PM T</b>				
	+ 1.5 HRS ARR	(OL)	May,R	ONLINE	Christou,D REMOTE				
24799	12:00-12:15PM	MW	Artiaga,B	REMOTE	28004	0.5 HRS ARR	(OL)	Chan,J	ONLINE
	12:15-12:50PM	MW	Artiaga,B	REMOTE		+ 1.5 HRS ARR	(OL)	Chan,J	ONLINE
24801	4:00- 4:15PM	MW	STAFF	REMOTE	29334	0.5 HRS ARR	(OL)	Chan,J	ONLINE
	4:15- 4:50PM	MW	STAFF	REMOTE		+ 1.5 HRS ARR	(OL)	Chan,J	ONLINE
<b>26482</b>	<b>6:00- 6:15PM</b>	<b>MW</b>	STAFF	REMOTE	29336	0.5 HRS ARR	(OL)	Fritzler,A	ONLINE
	<b>6:15- 6:50PM</b>	<b>MW</b>	STAFF	REMOTE		+ 1.5 HRS ARR	(OL)	Fritzler,A	ONLINE
24807	11:00-11:15AM	TTh	Buttler Jr.,V	REMOTE	30430	1:00- 1:30PM	Sun	Christou,D	REMOTE
	11:15-11:50AM	TTh	Buttler Jr.,V	REMOTE		1:30- 3:20PM	Sun	Christou,D	REMOTE
24809	9:00- 9:15AM	TTh	Richardson,C	REMOTE	Class# 30430 meets 08/23/2020-12/06/2020				
	9:15- 9:50AM	TTh	Richardson,C	REMOTE	<b>PEX 153 - 1.0 UNIT MEDITATIVE - YOGA AND STRESS REDUCTION</b>				
24811	10:00-10:15AM	TTh	Richardson,C	REMOTE	Transferable to UC, CSU				
	10:15-10:50AM	TTh	Richardson,C	REMOTE	<b>30432</b>	<b>7:30- 8:00PM T</b>		Christou,D	REMOTE
<b>26262</b>	<b>7:00- 7:15PM</b>	<b>MW</b>	Allen,M	REMOTE		<b>8:00- 9:20PM T</b>		Christou,D	REMOTE
	<b>7:15- 7:50PM</b>	<b>MW</b>	Allen,M	REMOTE	<b>PEX 155 - 1.0 UNIT PIYO INTRODUCTION TO PILATES AND YOGA</b>				
24819	5:00- 5:15PM	TTh	Allen,M	REMOTE	Transferable to UC, CSU				
	<b>5:15- 5:50PM</b>	<b>TTh</b>	Allen,M	REMOTE	27724	0.5 HRS ARR	(OL)	Chan,J	ONLINE
24979	6:00- 6:15AM	MW	Gonzalez,R	REMOTE		+ 1.5 HRS ARR	(OL)	Chan,J	ONLINE
	6:15- 6:50AM	MW	Gonzalez,R	REMOTE	27726	4:00- 4:30PM	T	Christou,D	REMOTE
29330	1:00- 1:30PM	TTh	STAFF	REMOTE		4:30- 5:50PM	T	Christou,D	REMOTE
	1:30- 1:50PM	TTh	STAFF	REMOTE	<b>PEX 156 - 1.0 UNIT PILATES CONDITIONING</b>				
29332	12:00-12:15PM	TTh	Buttler Jr.,V	REMOTE	Transferable to UC, CSU				
	12:15-12:50PM	TTh	Buttler Jr.,V	REMOTE	24841	0.5 HRS ARR	(OL)	Chan,J	ONLINE
<b>29655</b>	<b>7:00- 7:15PM</b>	<b>TTh</b>	Marquez,O	REMOTE		+ 1.5 HRS ARR	(OL)	Chan,J	ONLINE
	<b>7:15- 7:50PM</b>	<b>TTh</b>	Marquez,O	REMOTE	24843	4:00- 4:30PM	T	Christou,D	REMOTE
						4:30- 5:50PM	T	Christou,D	REMOTE
<b>PEX 147 - 1.0 UNIT PERSONAL SELF DEFENSE</b>					<b>PEX 157 - 1.0 UNIT DANCE CONDITIONING AND ALIGNMENT</b>				
Transferable to UC, CSU					Transferable to UC, CSU				
24821	12:00-12:30PM	F	STAFF	REMOTE	30296	11:00-11:15AM	MW	Roman-Rodriguez,D	REMOTE
	12:30- 1:50PM	F	STAFF	REMOTE		11:15-11:50AM	MW	Roman-Rodriguez,D	REMOTE
25942	3:30- 4:00PM	M	Wikert Hoag,R	REMOTE	30298	11:00-11:15AM	TTh	Horner,B	REMOTE
	4:00- 5:20PM	M	Wikert Hoag,R	REMOTE		11:15-11:50AM	TTh	Horner,B	REMOTE
<b>PEX 148 - 1.0 UNIT BRAZILIAN JIU JITSU</b>					<b>PEX 161 - 1.0 UNIT BADMINTON, BEGINNING</b>				
Transferable to UC, CSU					Transferable to UC, CSU				
30294	0.5 HRS ARR	(OL)	Celis,J	ONLINE	24861	11:00-11:15AM	MW	STAFF	REMOTE
	+ 4.5 HRS ARR	(OL)	Celis,J	ONLINE		11:15-11:50AM	MW	STAFF	REMOTE
<b>PEX 149 - 1.0 UNIT TAE KWON DO, BEGINNING</b>					<b>PEX 162 - 1.5 UNITS BADMINTON FITNESS AND TECHNIQUE TRAINING</b>				
Transferable to UC, CSU					Transferable to UC, CSU				
25938	0.5 HRS ARR	(OL)	Coliflores,V	ONLINE	28213	11:00-11:30AM	MW	STAFF	REMOTE
	+ 1.5 HRS ARR	(OL)	Coliflores,V	ONLINE		11:30-12:20PM	MW	STAFF	REMOTE
<b>PEX 151 - 1.0 UNIT YOGA</b>					<b>PEX 165 - 1.0 UNIT BASKETBALL, NOVICE</b>				
Transferable to UC, CSU					Transferable to UC, CSU				
24825	0.5 HRS ARR	(OL)	Hammond,J	ONLINE	24863	0.5 HRS ARR	(OL)	May,R	ONLINE
	+ 1.5 HRS ARR	(OL)	Hammond,J	ONLINE		+ 1.5 HRS ARR	(OL)	May,R	ONLINE
24827	0.5 HRS ARR	(OL)	Hammond,J	ONLINE	<b>24999</b>	<b>7:00- 7:15PM</b>	<b>TTh</b>	Ortiz,T	REMOTE
	+ 1.5 HRS ARR	(OL)	Hammond,J	ONLINE		<b>7:15- 7:50PM</b>	<b>TTh</b>	Ortiz,T	REMOTE
24829	2:00- 2:30PM	T	STAFF	REMOTE	<b>PEX 166 - 1.0 UNIT BASKETBALL, BEGINNING</b>				
	2:30- 3:50PM	T	STAFF	REMOTE	Transferable to UC, CSU				
24831	0.5 HRS ARR	(OL)	Fritzler,A	ONLINE	24865	0.5 HRS ARR	(OL)	May,R	ONLINE
	+ 1.5 HRS ARR	(OL)	Fritzler,A	ONLINE		+ 1.5 HRS ARR	(OL)	May,R	ONLINE
24837	0.5 HRS ARR	(OL)	Chan,J	ONLINE	<b>24867</b>	<b>7:00- 7:15PM</b>	<b>TTh</b>	Ortiz,T	REMOTE
	+ 1.5 HRS ARR	(OL)	Chan,J	ONLINE		<b>7:15- 7:50PM</b>	<b>TTh</b>	Ortiz,T	REMOTE
27718	0.5 HRS ARR	(OL)	Fritzler,A	ONLINE					
	+ 1.5 HRS ARR	(OL)	Fritzler,A	ONLINE					

If a class displays as **REMOTE** in the schedule, students will be expected to log into the class at a specified day/time (e.g., MW 8-9:15am). If the class displays as **ONLINE** in the schedule, students are permitted to log into the class whenever they are available to complete coursework by the established deadlines.

Students not in attendance or late for the first class meeting are subject to drop.



Class#	Time	Day	Instructor	Room	Class#	Time	Day	Instructor	Room
<b>PEX 167 - 1.0 UNIT BOWLING, BEGINNING</b>					<b>PEX 245 - 2.0 UNITS CIRCUIT WEIGHT TRAINING, INTERMEDIATE/ADVANCED</b>				
Transferable to UC, CSU					Transferable to UC, CSU				
26484	0.5 HRS ARR	(OL)	Haley Peaslee,D	ONLINE	24910	1.0 HRS ARR	(OL)	May,R	ONLINE
	+ 1.5 HRS ARR	(OL)	Haley Peaslee,D	ONLINE		+ 3.0 HRS ARR	(OL)	May,R	ONLINE
<b>PEX 176 - 1.0 UNIT GOLF, BEGINNING</b>					<b>PEX 249 - 2.0 UNITS TAE KWON DO, INTERMEDIATE/ADVANCED</b>				
Transferable to UC, CSU					Transferable to UC, CSU				
24870	9:00- 9:30AM	F	Caines,T	REMOTE	25940	1.0 HRS ARR	(OL)	Coliflores,V	ONLINE
	9:30-10:50AM	F	Caines,T	REMOTE		+ 3.0 HRS ARR	(OL)	Coliflores,V	ONLINE
<b>PEX 178 - 1.0 UNIT SOCCER, BEGINNING</b>					<b>PEX 265 - 2.0 UNITS BASKETBALL, INTERMEDIATE</b>				
Transferable to UC, CSU					Transferable to UC, CSU				
25005	10:00-10:15AM	MW	Artiaga,B	REMOTE	24924	1.0 HRS ARR	(OL)	May,R	ONLINE
	10:15-10:50AM	MW	Artiaga,B	REMOTE		+ 3.0 HRS ARR	(OL)	May,R	ONLINE
<b>PEX 179 - 1.0 UNIT SOCCER, FITNESS AND TECHNIQUE</b>					<b>PEX 266 - 2.0 UNITS BASKETBALL, ADVANCED</b>				
Transferable to UC, CSU					Transferable to UC, CSU				
24874	11:00-11:15AM	MW	Artiaga,B	REMOTE	24926	1.0 HRS ARR	(OL)	May,R	ONLINE
	11:15-11:50AM	MW	Artiaga,B	REMOTE		+ 3.0 HRS ARR	(OL)	May,R	ONLINE
<b>PEX 184 - 1.0 UNIT SWIMMING, NOVICE</b>					<b>PEX 270 - 2.0 UNITS BASKETBALL, ADVANCED</b>				
Transferable to UC, CSU					Transferable to UC, CSU				
24876	10:00-10:15AM	TTh	Macias,S	REMOTE	25015	7:00-7:30PM	TTh	Ortiz,T	REMOTE
	10:15-10:50AM	TTh	Macias,S	REMOTE		7:30- 8:50PM	TTh	Ortiz,T	REMOTE
24880	10:00-10:15AM	MW	STAFF	REMOTE	<b>PEX 267 - 2.0 UNITS BOWLING, INTERMEDIATE/ADVANCED</b>				
	10:15-10:50AM	MW	STAFF	REMOTE	Transferable to UC, CSU				
24882	12:00-12:15PM	MW	Abing,J	REMOTE	26486	12:00-12:30PM	F	Haley Peaslee,D	REMOTE
	12:15- 1:50PM	MW	Abing,J	REMOTE		+ 3.0 HRS ARR	F	Haley Peaslee,D	REMOTE
30300	2:00- 2:15PM	TTh	Abing,J	REMOTE		12:30- 1:50PM	F	Haley Peaslee,D	REMOTE
	2:15- 2:50PM	TTh	Abing,J	REMOTE	<b>PEX 276 - 2.0 UNITS GOLF, INTERMEDIATE/ADVANCED</b>				
30434	2:00- 2:15PM	TTh	Abing,J	REMOTE	Transferable to UC, CSU				
	2:15- 2:50PM	TTh	Abing,J	REMOTE	24928	1.0 HRS ARR	Caines,T		
25944	3:00- 3:30PM	MW	STAFF	REMOTE		9:00-10:00AM	F	Caines,T	REMOTE
	3:30- 4:50PM	MW	STAFF	REMOTE		10:00-10:50AM	F	Caines,T	REMOTE
Class# 25944 meets 10/19/2020-12/06/2020					<b>PEX 278 - 2.0 UNITS SOCCER, INTERMEDIATE/ADVANCED</b>				
<b>PEX 185 - 1.0 UNIT SWIMMING, BEGINNING</b>					Transferable to UC, CSU				
Transferable to UC, CSU					24930	9:00- 9:30AM	TTh	Artiaga,B	REMOTE
24884	10:00-10:15AM	TTh	Macias,S	REMOTE		9:30-10:50AM	TTh	Artiaga,B	REMOTE
	10:15-10:50AM	TTh	Macias,S	REMOTE	25019	8:00- 8:30AM	MW	Artiaga,B	REMOTE
24886	10:00-10:15AM	MW	STAFF	REMOTE		8:30- 9:50AM	MW	Artiaga,B	REMOTE
	10:15-10:50AM	MW	STAFF	REMOTE	<b>PEX 284 - 2.0 UNITS SWIMMING, INTERMEDIATE</b>				
25007	12:00-12:15PM	MW	Abing,J	REMOTE	Transferable to UC, CSU				
	12:15- 1:50PM	MW	Abing,J	REMOTE	24932	12:00-12:30PM	MW	Abing,J	REMOTE
25946	3:00- 3:30PM	MW	STAFF	REMOTE		12:30- 1:50PM	MW	Abing,J	REMOTE
	3:30- 4:50PM	MW	STAFF	REMOTE	24934	9:00- 9:30AM	TTh	Macias,S	REMOTE
Class# 25946 meets 10/19/2020-12/06/2020						9:30-10:50AM	TTh	Macias,S	REMOTE
<b>PEX 188 - 1.0 UNIT TENNIS, INTRODUCTION</b>					<b>PEX 280 - 2.0 UNITS SOCCER, INTERMEDIATE/ADVANCED</b>				
Transferable to UC, CSU					Transferable to UC, CSU				
29338	9:00- 9:30AM	TTh	STAFF	REMOTE	24936	9:00- 9:30AM	MW	STAFF	REMOTE
	9:30-10:50AM	TTh	STAFF	REMOTE		9:30-10:50AM	MW	STAFF	REMOTE
Class# 29338 meets 08/17/2020-10/14/2020					30302	2:00- 2:30PM	TTh	Abing,J	REMOTE
<b>PEX 189 - 1.0 UNIT TENNIS, BEGINNING</b>						2:30- 3:50PM	TTh	Abing,J	REMOTE
Transferable to UC, CSU					<b>PEX 240 - 2.0 UNITS JOGGING FOR FITNESS, INTERMEDIATE</b>				
29340	9:00- 9:30AM	TTh	STAFF	REMOTE	Transferable to UC, CSU				
	9:30-10:50AM	TTh	STAFF	REMOTE	24904	7:30- 8:00AM	MW	STAFF	REMOTE
Class# 29340 meets 08/17/2020-10/14/2020						8:00- 9:20AM	MW	STAFF	REMOTE
<b>PEX 191 - 1.0 UNIT VOLLEYBALL, INTRODUCTION</b>					<b>PEX 248 - 2.0 UNITS GOLF, INTERMEDIATE/ADVANCED</b>				
Transferable to UC, CSU					Transferable to UC, CSU				
24896	9:00- 9:15AM	TTh	Gnodle,D	REMOTE	24912	4:00- 4:30PM	MW	STAFF	REMOTE
	9:15- 9:50AM	TTh	Gnodle,D	REMOTE		<b>4:30- 5:50PM</b>	<b>MW</b>	STAFF	REMOTE
<b>24899</b>	<b>7:00- 8:20PM</b>	<b>M</b>	Velazquez-Ortega,M	REMOTE	24916	11:00-11:30AM	TTh	Buttler Jr.,V	REMOTE
<b>25573</b>	<b>6:30-7:00PM</b>	<b>M</b>	Velazquez-Ortega,M	REMOTE		11:30-12:50PM	TTh	Buttler Jr.,V	REMOTE
<b>PEX 192 - 1.0 UNIT VOLLEYBALL, BEGINNING</b>					<b>PEX 249 - 2.0 UNITS SOCCER, INTERMEDIATE/ADVANCED</b>				
Transferable to UC, CSU					Transferable to UC, CSU				
24900	9:00- 9:15AM	TTh	Gnodle,D	REMOTE	24918	9:00- 9:30AM	TTh	Richardson,C	REMOTE
	9:15- 9:50AM	TTh	Gnodle,D	REMOTE		9:30-10:50AM	TTh	Richardson,C	REMOTE
<b>24902</b>	<b>6:30- 7:00PM</b>	<b>M</b>	Velazquez-Ortega,M	REMOTE	<b>24920</b>	<b>5:00- 5:30PM</b>	<b>TTh</b>	Allen,M	REMOTE
	<b>7:00- 8:20PM</b>	<b>M</b>	Velazquez-Ortega,M	REMOTE		<b>5:30- 6:50PM</b>	<b>TTh</b>	Allen,M	REMOTE
<b>PEX 240 - 2.0 UNITS JOGGING FOR FITNESS, INTERMEDIATE</b>					<b>PEX 250 - 2.0 UNITS GOLF, INTERMEDIATE/ADVANCED</b>				
Transferable to UC, CSU					Transferable to UC, CSU				
24904	7:30- 8:00AM	MW	STAFF	REMOTE	25574	12:00-12:30PM	MW	Artiaga,B	REMOTE
	8:00- 9:20AM	MW	STAFF	REMOTE		12:30- 1:50PM	MW	Artiaga,B	REMOTE

If a class displays as **REMOTE** in the schedule, students will be expected to log into the class at a specified day/time (e.g., MW 8-9:15am). If the class displays as **ONLINE** in the schedule, students are permitted to log into the class whenever they are available to complete coursework by the established deadlines.

Students not in attendance or late for the first class meeting are subject to drop.

Class#	Time	Day	Instructor	Room	Class#	Time	Day	Instructor	Room
<b>PEX 285 - 2.0 UNITS SWIMMING, ADVANCED</b> Transferable to UC, CSU					<b>PTA 120 - 4.0 UNITS KINESIOLOGY</b> Transferable to CSU				
24938	12:00-12:30PM	MW	Abing,J	REMOTE					
	12:30-1:50PM	MW	Abing,J	REMOTE					
24940	9:00- 9:30AM	MW	STAFF	REMOTE					
	9:30-10:50AM	MW	STAFF	REMOTE	20525	4:00- 6:50PM	W	Christensen,V	REMOTE
25021	9:00- 9:30AM	TTh	Macias,S	REMOTE					
	9:30-10:50AM	TTh	Macias,S	REMOTE					
30304	2:00- 2:30PM	TTh	Abing,J	REMOTE	20526	4:00- 6:50PM	Th	Ingstad,C	HS302
	2:30- 3:50PM	TTh	Abing,J	REMOTE	<b>20810</b>	<b>7:00- 9:50PM</b>	<b>Th</b>	Ingstad,C	HS302
					30572	8:00-10:50AM	Th	Ingstad,C	HS302

<b>PEX 291 - 2.0 UNITS VOLLEYBALL, INTERMEDIATE</b> Transferable to UC, CSU				
24946	9:00- 9:30AM	TTh	Gnodle,D	REMOTE
	9:30-10:50AM	TTh	Gnodle,D	REMOTE
<b>24948</b>	<b>6:30- 7:30PM</b>	<b>M</b>	Velazquez-Ortega,M	REMOTE
	<b>7:30-10:20PM</b>	<b>M</b>	Velazquez-Ortega,M	REMOTE

<b>PEX 292 - 2.0 UNITS VOLLEYBALL, ADVANCED</b> Transferable to UC, CSU				
24950	9:00- 9:30AM	TTh	Gnodle,D	REMOTE
	9:30-10:50AM	TTh	Gnodle,D	REMOTE
<b>24952</b>	<b>6:30- 7:30PM</b>	<b>M</b>	Velazquez-Ortega,M	REMOTE
	<b>7:30-10:20PM</b>	<b>M</b>	Velazquez-Ortega,M	REMOTE

## PHYSICAL SCIENCE

<b>PS 100 - 3.0 UNITS PHYSICAL SCIENCE OF MODERN TECHNOLOGY</b> Transferable to UC, CSU Prerequisite: MATH 40 or equivalent with a grade of "C" or higher or "Pass" or completion of the math placement process with a score eligible for MATH 60.				
<b>23993</b>	<b>7:00-9:50PM</b>	<b>W</b>	Afrasiabi,J	REMOTE

<b>PS 112 - 3.0 UNITS PHYSICAL SCIENCE FOR ELEMENTARY SCHOOL TEACHERS</b> Transferable to CSU Prerequisite: MATH 105 or MATH 110A or equivalent with a grade of "C" or higher or "Pass" or concurrent enrollment.				
28255	11:30-12:30PM	TTh	Patra,S	REMOTE
	12:30- 1:50PM	TTh	Patra,S	REMOTE
Targeted for Future Teachers but Open to all Students EXAMS ONLY: September 15- Test 1, 2:00 p.m. to 2:30 p.m.; October 6 - Test 2, 2:00 p.m. to 2:30 p.m.; November 10 - Test 3, 2:00 p.m. to 2:30 p.m.; December 15 - Final Exam, 2:00 p.m. to 4:00 p.m.				

## PHYSICAL THERAPIST ASSISTANT

Applications for Fall 2021 admission to the Physical Therapist Assistant Program are due in the Health Occupations Division Office no later than April 15, 2021. STUDENTS MUST BE ACCEPTED INTO THE PTA PROGRAM PRIOR TO ENROLLING IN ANY CLASS. For more information call (562) 860-2451, Ext. 2550. Clearance of a criminal background check and/or drugs of abuse testing may be required prior to clinical field experience.

<b>PTA 110 - 4.0 UNITS INTRODUCTION TO PHYSICAL THERAPY</b> Transferable to CSU				
20523	2:00- 4:50PM	M	Christensen,V	REMOTE
PLEASE ENROLL IN LAB SECTION OF YOUR CHOICE. THE LECTURE SECTION #20523 WILL BE AUTOMATICALLY ADDED.				
20524	1:00- 3:50PM	T	Coursey,N	HS302
<b>20809</b>	<b>7:00- 9:50PM</b>	<b>T</b>	Coursey,N	HS302
<b>30571</b>	<b>7:00- 9:50PM</b>	<b>M</b>	Coursey,N	HS302

<b>PTA 129 - 1.5 UNITS PHYSICAL THERAPY ASPECTS OF AGING AND INTEGUMENTARY MANEGEME</b> Transferable to CSU				
<b>22194</b>	<b>5:00-7:50PM</b>	<b>T</b>	Ingstad,C	REMOTE
Class# 22194 meets 08/18/2020-10/13/2020				

<b>PTA 230 - 4.0 UNITS THERAPEUTIC EXERCISE</b> Transferable to CSU Prerequisite: PTA 120 or equivalent with a grade of Pass or "C" or higher.				
<b>20527</b>	<b>7:00- 9:50PM</b>	<b>M</b>	Ingstad,C	REMOTE
PLEASE ENROLL IN LAB SECTION OF YOUR CHOICE. THE LECTURE SECTION #20527 WILL BE AUTOMATICALLY ADDED.				
20811	4:00- 6:50PM	W	De Haas,L	HS302
<b>20812</b>	<b>7:00- 9:50PM</b>	<b>W</b>	De Haas,L	HS302
<b>30573</b>	<b>7:00- 9:50PM</b>	<b>T</b>	Ingstad,C	GA

<b>PTA 233 - 2.0 UNITS PROSTHETICS AND ORTHOTICS FOR ALLIED HEALTH PROFESSIONALS</b> Transferable to CSU NOTE: a material fee of \$49.00 is required for PTA 233				
<b>20813</b>	<b>5:00- 6:50PM</b>	<b>M</b>	De Haas,L	REMOTE

<b>PTA 236 - 4.0 UNITS CLINICAL PRACTICUM II</b> Transferable to CSU Prerequisite: PTA 125 or equivalent with a grade of Pass or "C" or higher. NOTE: a material fee of \$13.00 is required for PTA 236				
20528	12.3 HRS ARR		Christensen,V	TBD *

## PHYSICS

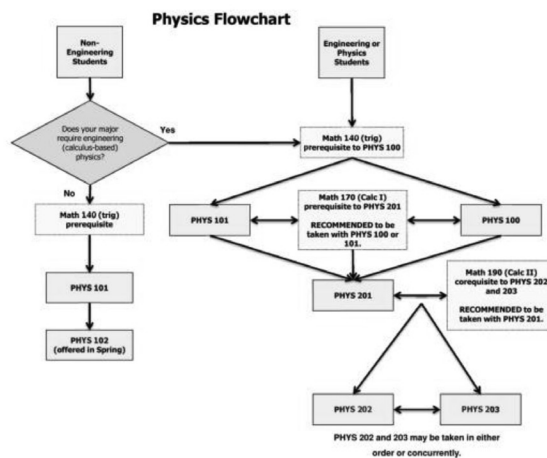

<b>PHYS 100 - 4.0 UNITS ELEMENTARY PHYSICS</b> Transferable to UC, CSU Prerequisite: MATH 140 or equivalent with a grade of "C" or higher or "Pass" or completion of the math placement process with a score eligible for MATH 155.				
20481	+ 3.0 HRS ARR	(OL)	Takemae,S	ONLINE
20482	3.0 HRS ARR	(OL)	Takemae,S	ONLINE
27957	3.0 HRS ARR	(OL)	Takemae,S	ONLINE
<b>30212</b>	<b>7:00- 9:50PM</b>	<b>W</b>	Szabo,T	REMOTE
	+ 3.0 HRS ARR	(OL)	Patra,S	ONLINE

If a class displays as **REMOTE** in the schedule, students will be expected to log into the class at a specified day/time (e.g., MW 8-9:15am). If the class displays as **ONLINE** in the schedule, students are permitted to log into the class whenever they are available to complete coursework by the established deadlines.

Students not in attendance or late for the first class meeting are subject to drop.

Class#	Time	Day	Instructor	Room	Class#	Time	Day	Instructor	Room
--------	------	-----	------------	------	--------	------	-----	------------	------

**PHYS 101 - 4.0 UNITS GENERAL PHYSICS**

Transferable to UC, CSU (CAN PHYS 2)(CAN PHYS SEQ A)  
Prerequisite: MATH 140 or equivalent with a grade of "C" or higher or "Pass."

20484	7:00- 9:50PM	M	Said,A	REMOTE
	5:30- 6:45PM	MW	Said,A	REMOTE
Note: Access to a webcam is required.				
29701	10:00-12:50PM	F	Said,A	REMOTE
Note: Access to a webcam is required.				
	1:00- 3:50PM	F	Said,A	REMOTE

**PHYS 201 - 4.0 UNITS ENGINEERING PHYSICS**

Transferable to UC, CSU (CAN PHYS 8)(CAN PHYS SEQ B)  
Prerequisite: PHYS 100 or PHYS 101 and MATH 170 or equivalents with grades of "C" or higher or "Pass."

29653	2:00- 4:50PM	M	Said,A	REMOTE
Note: Access to a webcam is required.				
	2:00- 4:50PM	W	Said,A	REMOTE
27063	9:00-12:15PM	Sat	Mera,C	REMOTE
Note: Orientation: Mandatory Zoom meeting Saturday Aug 22, 9:00 a.m. Access to a webcam required.				
	12:45- 3:55PM	Sat	Mera,C	REMOTE
Class# 27063 meets 08/22/2020-12/12/2020				
20786	5:30- 7:20PM	TWTh	Mera,C	REMOTE
Note: Orientation: Mandatory Zoom meeting Tuesday Aug 18, 7:30 p.m. Access to a webcam required.				
	7:20- 9:20PM	TWTh	Mera,C	REMOTE
Class# 20786 meets 08/17/2020-10/16/2020				

**PHYS 202 - 4.0 UNITS ENGINEERING PHYSICS**

Transferable to UC, CSU (CAN PHYS 12)(CAN PHYS SEQ B)  
Prerequisite: PHYS 201 and MATH 170 or equivalents with grades of "C" or higher or "Pass."

Corequisite: MATH 190 or prior completion of MATH 190 or equivalent with a grade of "C" or higher or "Pass."				
20788	2:00- 3:15PM	MW	Buschauer,R	REMOTE
20789	4:00- 6:50PM	M	Mera,C	REMOTE
Note: Orientation: Mandatory Zoom meeting Monday Aug 17, 4:00 p.m. Access to a webcam required.				
24338	11:00- 1:50PM	W	Mera,C	REMOTE
Note: Orientation: Mandatory Zoom meeting Wednesday Aug 19, 11:00 a.m. Access to a webcam required.				

**PHYS 203 - 4.0 UNITS ENGINEERING PHYSICS**

Transferable to UC, CSU (CAN PHYS 14)(CAN PHYS SEQ B)  
Prerequisite: PHYS 201 and MATH 170 or equivalents with grades of "C" or higher or "Pass." Corequisite: MATH 190 or prior completion of MATH 190 or equivalent with a grade of "C" or higher or "Pass."

22810	2:00- 4:50PM	T	Said,A	REMOTE
Note: Access to a webcam is required.				
	2:00- 4:50PM	Th	Said,A	REMOTE
27984	5:30- 7:20PM	TWTh	Mera,C	REMOTE
Note: Orientation: Mandatory Zoom meeting Tuesday October 20, 7:30 p.m. Access to a webcam required.				
	7:20- 9:20PM	TWTh	Mera,C	REMOTE
Class# 27984 meets 10/19/2020-12/18/2020				

**PLASTICS/COMPOSITES MANUFACTURING TECHNOLOGY**

Please read the technical standards relevant to this department at <http://cms.cerritos.edu/technology/standards.htm>

**PMT 51 - 2.5 UNITS COMPOSITES FABRICATION**

Not Transferable  
Recommendation: PMT 70 or equivalent with a grade of Pass or "C" or higher or appropriate work experience. NOTE: a material fee of \$10.00 is required for PMT 51

27124	4.0 HRS ARR	(OL)	Fitzgerald,B	ONLINE
	11:00-12:50PM	MW	Fitzgerald,B	ME 1

The lab portion of this class will be a hybrid - partially on campus & partially online. The class will be divided into two groups. Each group will be on campus partially. You will be contacted by your instructor on which group you will be assigned to.

Class# 27124 meets 10/19/2020-12/18/2020

**PMT 76 - 3.0 UNITS VACUUM INFUSION PROCESS (VIP)/RESIN TRANSFER MOLDING (RTM)**

Not Transferable  
NOTE: a material fee of \$10.00 is required for PMT 76

30011	3.6 HRS ARR	(OL)	Fitzgerald,B	ONLINE
	+ 1.2 HRS ARR	(OL)	Fitzgerald,B	ONLINE
Class# 30011 meets 09/08/2020-12/18/2020				

**PMT 100 - 2.5 UNITS PLASTICS TECHNOLOGY**

Transferable to CSU  
NOTE: a material fee of \$10.00 is required for PMT 100

22768	2.0 HRS ARR	(OL)	Li,D	ONLINE
	+ 2.0 HRS ARR	(OL)	Li,D	ONLINE

**POLITICAL SCIENCE**

**POL 101 - 3.0 UNITS AMERICAN POLITICAL INSTITUTIONS**

Transferable to UC, CSU (CAN GOVT 2)  
Recommendation: Satisfactory completion of the English Placement Process or ENGL 20 or equivalent with a grade of Pass or "C" or higher and satisfactory completion of the Reading Placement Process or READ 43 or equivalent with a grade of Pass or "C" or higher.

23786	3.0 HRS ARR	(OL)	Falcon,D	ONLINE
Note: Visit <a href="http://www.cerritos.edu/dfalcon">www.cerritos.edu/dfalcon</a> and follow all instructions on that site no later than midnight of the second day of the semester to satisfy the orientation requirement for this class. Students failing to do this may be dropped as no show."				
20486	9:30-10:45AM	MW	Obazuaye,S	REMOTE
20487	9:30-12:20PM	F	STAFF	REMOTE
20488	3.0 HRS ARR	(OL)	Obasohan,V	ONLINE
20489	11:00-12:15PM	MW	Falcon,D	REMOTE
20490	3.0 HRS ARR	(OL)	Obasohan,V	ONLINE
20491	3.0 HRS ARR	(OL)	Falcon,D	ONLINE
Note: Visit <a href="http://www.cerritos.edu/dfalcon">www.cerritos.edu/dfalcon</a> and follow all instructions on that site no later than midnight of the second day of the semester to satisfy the orientation requirement for this class. Students failing to do this may be dropped as no show."				
20492	3.0 HRS ARR	(OL)	Obazuaye,S	ONLINE
Orientation: 10:00 a.m. - 12:00 p.m., Friday - August 21 in HS102.				
20493	3.0 HRS ARR	(OL)	Obasohan,V	ONLINE
20494	7:00- 9:50PM	W	STAFF	REMOTE
20495	3.0 HRS ARR	(OL)	Obasohan,V	ONLINE
20496	9:30-10:45AM	TTh	Falcon,D	REMOTE
23787	3.0 HRS ARR	(OL)	Falcon,D	ONLINE
Note: Visit <a href="http://www.cerritos.edu/dfalcon">www.cerritos.edu/dfalcon</a> and follow all instructions on that site no later than midnight of the second day of the semester to satisfy the orientation requirement for this class. Students failing to do this may be dropped as no show.				
20497	3.0 HRS ARR	(OL)	Obasohan,V	ONLINE
20498	11:00-12:15PM	TTh	STAFF	REMOTE
23788	7:00- 9:50PM	T	STAFF	REMOTE
20791	3.0 HRS ARR	(OL)	Obasohan,V	ONLINE
30641	3.0 HRS ARR	(OL)	Mullins,T	ONLINE
Note: All class information will be available in Canvas.				
20793	3.0 HRS ARR	(OL)	STAFF	ONLINE
Orientation will be conducted online. Instructor will email instructions to enrolled students one week before the start of class.				
20794	3.0 HRS ARR	(OL)	Mullins,T	ONLINE
21276	3.0 HRS ARR	(OL)	Mullins,T	ONLINE
Orientation will be conducted online. Instructor will email instructions to enrolled students one week before the start of class.				
23873	8:00- 9:15AM	MW	STAFF	REMOTE
23874	11:00-12:15PM	MW	Obazuaye,S	REMOTE
23875	3.0 HRS ARR	(OL)	Mullins,T	REMOTE
Orientation will be conducted online. Instructor will email instructions to enrolled students one week before the start of class.				
22052	3.0 HRS ARR	(OL)	Mullins,T	ONLINE
21700	12:30- 1:45PM	TTh	Falcon,D	REMOTE
22119	9:30-10:45AM	MW	STAFF	REMOTE
25930	12:30- 1:45PM	MW	Falcon,D	REMOTE
25992	5:30- 6:45PM	TTh	STAFF	REMOTE

If a class displays as **REMOTE** in the schedule, students will be expected to log into the class at a specified day/time (e.g., MW 8-9:15am). If the class displays as **ONLINE** in the schedule, students are permitted to log into the class whenever they are available to complete coursework by the established deadlines.

Students not in attendance or late for the first class meeting are subject to drop.

Class#	Time	Day	Instructor	Room	Class#	Time	Day	Instructor	Room
29276	6:00- 8:50PM	W	STAFF	REMOTE	27931	6.0 HRS ARR	(OL)	Duff,K	ONLINE
30642	3.0 HRS ARR	(OL)	STAFF	ONLINE	Note: There is no on campus orientation; course is 100% online. Instructor will email students with course information on the first day of the semester. Information will also be posted in Canvas, available through the Cerritos College website. Students must be online by midnight of the first day of class. Waitlist students will be emailed by instructor if they can be added.				
20935	3.6 HRS ARR	(OL)	Obazuaye,S	ONLINE	Class# 27931 meets 08/17/2020-10/16/2020				
Orientation: 10:00 a.m. - 12:00 p.m., Friday - September 11 in HS102.					22443	6.0 HRS ARR	(OL)	Lewellen,R	ONLINE
21275	3.6 HRS ARR	(OL)	STAFF	ONLINE	Note: There is no on campus orientation; course is 100% online. Instructor will email students with course information on the first day of the semester. Information will also be posted in Canvas, available through the Cerritos College website. Students must be online by midnight of the first day of class. Waitlist students will be emailed by instructor if they can be added.				
Orientation will be conducted online. Instructor will email instructions to enrolled students one week before the start of class.					Class# 22443 meets 08/17/2020-10/16/2020				
Class# 21275 meets 09/08/2020-12/18/2020					29103	6.0 HRS ARR	(OL)	St. John,H	ONLINE
23994	3.6 HRS ARR	(OL)	STAFF	ONLINE	Note: There is no on campus orientation; course is 100% online. Instructor will email students with course information on the first day of the semester. Information will also be posted in Canvas, available through the Cerritos College website. Students must be online by midnight of the first day of class. Waitlist students will be emailed by instructor if they can be added.				
Orientation will be conducted online. Instructor will email instructions to enrolled students one week before the start of class.					Class# 29103 meets 08/17/2020-10/16/2020				
Class# 23994 meets 09/08/2020-12/18/2020					21731	6.0 HRS ARR	(OL)	Duff,K	ONLINE
23789	5:30- 7:05PM	MW	STAFF	REMOTE	Note: There is no on campus orientation; course is 100% online. Instructor will email students with course information on the first day of the semester. Information will also be posted in Canvas, available through the Cerritos College website. Students must be online by midnight of the first day of class. Waitlist students will be emailed by instructor if they can be added.				
Class# 23789 meets 09/09/2020-12/16/2020					Class# 21731 meets 10/19/2020-12/18/2020				
23790	5:00- 6:35PM	MW	STAFF	REMOTE	27932	6.0 HRS ARR	(OL)	Duff,K	ONLINE
Class# 23790 meets 09/09/2020-12/16/2020					Note: There is no on campus orientation; course is 100% online. Instructor will email students with course information on the first day of the semester. Information will also be posted in Canvas, available through the Cerritos College website. Students must be online by midnight of the first day of class. Waitlist students will be emailed by instructor if they can be added.				
25991	2:00- 3:30PM	TTh	STAFF	REMOTE	Class# 27932 meets 10/19/2020-12/18/2020				
Class# 25991 meets 09/08/2020-12/17/2020					27933	6.0 HRS ARR	(OL)	St. John,H	ONLINE
20795	6.0 HRS ARR	(OL)	STAFF	ONLINE	Note: There is no on campus orientation; course is 100% online. Instructor will email students with course information on the first day of the semester. Information will also be posted in Canvas, available through the Cerritos College website. Students must be online by midnight of the first day of class. Waitlist students will be emailed by instructor if they can be added.				
Note: Orientation will be conducted online. Instructor will email instructions to enrolled students one week before the start of class.					Class# 27933 meets 10/19/2020-12/18/2020				
Class# 20795 meets 10/19/2020-12/18/2020					27933	6.0 HRS ARR	(OL)	St. John,H	ONLINE
27466	7:00- 9:50PM	TTh	STAFF	REMOTE	Note: There is no on campus orientation; course is 100% online. Instructor will email students with course information on the first day of the semester. Information will also be posted in Canvas, available through the Cerritos College website. Students must be online by midnight of the first day of class. Waitlist students will be emailed by instructor if they can be added.				
Class# 27466 meets 10/20/2020-12/17/2020					Class# 27933 meets 10/19/2020-12/18/2020				
<b>POL 201 - 3.0 UNITS INTRODUCTION TO POLITICAL SCIENCE AND AMERICAN GOVERNMENT</b>									
Transferable to UC, CSU									
Recommendation: Satisfactory completion of the English Placement Process or ENGL 52 or equivalent with a grade of Pass or "C" or higher and satisfactory completion of the Reading Placement Process or READ 54 with a grade of Pass or "C" or higher.									
20796	3.0 HRS ARR	(OL)	Mullins,T	ONLINE					
24466	3.0 HRS ARR	(OL)	Mullins,T	ONLINE					
<b>POL 220 - 3.0 UNITS COMPARATIVE GOVERNMENT</b>									
Transferable to UC, CSU									
Recommendation: Satisfactory score on the English Placement Process or ENGL 52 with a grade of Pass or "C" or higher and satisfactory completion of the Reading Placement Process or READ 54 with a grade of Pass or "C" or higher.									
22886	6:00- 8:50PM	M	Obazuaye,S	REMOTE					
<b>PSYCHOLOGY</b>									
<b>PSYC 101 - 3.0 UNITS GENERAL INTRODUCTORY PSYCHOLOGY</b>									
Transferable to UC, CSU (CAN PSY 2)									
20500	8:00- 9:15AM	MW	Foley-Soulakis,S	REMOTE					
20501	9:30-10:45AM	MW	Chiros,S	REMOTE					
20502	3.0 HRS ARR	(OL)	St. John,H	ONLINE					
20503	11:00-12:15PM	MW	Chiros,S	REMOTE					
20504	3.0 HRS ARR	(OL)	Beas,V	ONLINE					
Thirty seats in this class are reserved for the Psychology House in the First Year Experience Program, which includes ENGL 100 (#27871), PSYC 210 (#29104), PSCY 210 LAB, and READ 101 (#30187). To learn more about FYE and to enroll in this house, please visit <a href="https://www.cerritos.edu/lcp/fye.htm">https://www.cerritos.edu/lcp/fye.htm</a> .									
25494	3.0 HRS ARR	(OL)	Larson,M	ONLINE					
20507	9:30-10:45AM	TTh	Sandoval,C	REMOTE					
20508	11:00-12:15PM	TTh	Fukunaga,K	REMOTE					
28143	3.0 HRS ARR	(OL)	Neuse,J	ONLINE					
29412	8:00- 9:15AM	TTh	Sandoval,C	REMOTE					
Note: There is no on campus orientation; course is 100% online. Instructor will email students with course information on the first day of the semester. Information will also be posted in Canvas, available through the Cerritos College website. Students must be online by midnight of the first day of class. Waitlist students will be emailed by instructor if they can be added.									
29715	1:20- 2:55PM	TTh	Pueblós,D	REMOTE					
Class# 29715 meets 09/08/2020-12/17/2020									
<b>PSYC 103 - 3.0 UNITS CRITICAL THINKING IN PSYCHOLOGY</b>									
Transferable to UC, CSU									
Prerequisite: ENGL 100 or or ENGL 100S or equivalent with a grade of "C" or higher or "Pass".									
27404	11:00-12:15PM	TTh	Grigoleit,T	REMOTE					
20511	12:30- 1:45PM	TTh	Nguyen,K	REMOTE					
20512	3:30- 4:45PM	MW	Pueblós,D	REMOTE					
20801	12:30- 1:45PM	MW	Pueblós,D	REMOTE					
20802	6:30- 9:20PM	M	Ledezma,E	REMOTE					
24468	9:30-10:45AM	TTh	Grigoleit,T	REMOTE					
25993	11:00-12:15PM	TTh	Griffin,W	REMOTE					
26061	3.0 HRS ARR	(OL)	Larson,M	ONLINE					
26078	11:00-12:15PM	MW	Griffin,W	REMOTE					
26739	6:30- 9:20PM	W	Ledezma,E	REMOTE					
27278	3.0 HRS ARR	(OL)	Huemer,S	ONLINE					
27279	9:30-10:45AM	MW	Garcia,A	REMOTE					
30383	3.0 HRS ARR	(OL)	St. John,H	ONLINE					
Note: There is no on campus orientation; course is 100% online. Instructor will email students with course information on the first day of the semester. Information will also be posted in Canvas, available through the Cerritos College website. Students must be online by midnight of the first day of class. Waitlist students will be emailed by instructor if they can be added.									
26738	3.6 HRS ARR	(OL)	Larson,M	ONLINE					
Class# 26738 meets 09/08/2020-12/18/2020									
<b>PSYC 150 - 3.0 UNITS PERSONAL AND SOCIAL ADJUSTMENT</b>									
Transferable to UC, CSU									
Recommendation: PSYC 101 and ENGL 52 or equivalent with grades or "Pass" or "C" or higher.									
20513	12:30- 1:45PM	TTh	Jasso,A	REMOTE					
20803	12:30- 4:00PM	M	Sanchez,V	REMOTE					
Class# 20803 meets 09/14/2020-12/14/2020									

If a class displays as **REMOTE** in the schedule, students will be expected to log into the class at a specified day/time (e.g., MW 8-9:15am). If the class displays as **ONLINE** in the schedule, students are permitted to log into the class whenever they are available to complete coursework by the established deadlines.

Students not in attendance or late for the first class meeting are subject to drop.

Class#	Time	Day	Instructor	Room	Class#	Time	Day	Instructor	Room
<b>PSYC 210 - 4.0 UNITS ELEMENTARY STATISTICS</b>					<b>PSYC 261 - 3.0 UNITS SOCIAL PSYCHOLOGY</b>				
Transferable to UC, CSU (CAN PSY 6)					Transferable to UC, CSU				
Prerequisite: MATH 75 or MATH 80 or equivalent with a grade of "C" or higher or "Pass" or satisfactory completion of the assessment/placement process with eligibility for PSYC 210.					Note: There is no on campus orientation; course is 100% online. Instructor will email students with course information on the first day of the semester. Information will also be posted in Canvas, available through the Cerritos College website. Students must be online by midnight of the first day of class. Waitlist students will be emailed by instructor if they can be added.				
27927	3.0 HRS ARR	(OL)	Alabi,B	ONLINE	22418	6.0 HRS ARR	(OL)	Duff,K	ONLINE
	+ 3.0 HRS ARR	(OL)	Alabi,B	ONLINE	Class# 22418 meets 08/17/2020-10/16/2020				
22308	12:30- 2:00PM	MW	Ronquillo-Adachi,J	REMOTE	29273	6.0 HRS ARR	(OL)	Duff,K	ONLINE
	2:00- 3:20PM	MW	Ronquillo-Adachi,J	REMOTE	Note: There is no on campus orientation; course is 100% online. Instructor will email students with course information on the first day of the semester. Information will also be posted in Canvas, available through the Cerritos College website. Students must be online by midnight of the first day of class. Waitlist students will be emailed by instructor if they can be added.				
20804	3.0 HRS ARR	(OL)	Sanchez,V	ONLINE	Class# 29273 meets 08/17/2020-10/16/2020				
	+ 3.0 HRS ARR	(OL)	Sanchez,V	ONLINE	24474	6.0 HRS ARR	(OL)	Duff,K	ONLINE
22888	3.0 HRS ARR	(OL)	Neuse,J	ONLINE	Note: There is no on campus orientation; course is 100% online. Instructor will email students with course information on the first day of the semester. Information will also be posted in Canvas, available through the Cerritos College website. Students must be online by midnight of the first day of class. Waitlist students will be emailed by instructor if they can be added.				
	+ 3.0 HRS ARR	(OL)	Neuse,J	ONLINE	Class# 24474 meets 10/19/2020-12/18/2020				
24469	3.0 HRS ARR	(OL)	Ronquillo-Adachi,J	ONLINE	30029	6.0 HRS ARR	(OL)	Duff,K	ONLINE
	+ 3.0 HRS ARR	(OL)	Ronquillo-Adachi,J	ONLINE	Note: There is no on campus orientation; course is 100% online. Instructor will email students with course information on the first day of the semester. Information will also be posted in Canvas, available through the Cerritos College website. Students must be online by midnight of the first day of class. Waitlist students will be emailed by instructor if they can be added.				
<b>24471</b>	<b>6:30- 8:00PM</b>	<b>TTh</b>	Giralt,N	REMOTE	Class# 30029 meets 10/19/2020-12/18/2020				
	<b>8:00- 9:20PM</b>	<b>TTh</b>	Giralt,N	REMOTE	<b>PSYC 271 - 3.0 UNITS ABNORMAL PSYCHOLOGY</b>				
27929	3.0 HRS ARR	(OL)	Sanchez,V	ONLINE	Transferable to UC, CSU				
	+ 3.0 HRS ARR	(OL)	Sanchez,V	ONLINE	Recommendation: ENGL 52 or equivalent with a grade of Pass or "C" or higher, and READ 54 or equivalent with a grade of Pass or "C" or higher.				
<b>28144</b>	<b>6:30- 8:00PM</b>	<b>MW</b>	Ter-Petrosyan,M	REMOTE	20522	9:30-10:45AM	TTh	Fukunaga,K	REMOTE
	<b>8:00- 9:20PM</b>	<b>MW</b>	Ter-Petrosyan,M	REMOTE	<b>20808</b>	<b>6:30- 9:20PM</b>	<b>W</b>	Jasso,A	REMOTE
29104	9:30-11:00AM	TTh	Beas,V	REMOTE	30384	3.0 HRS ARR	(OL)	St. John,H	ONLINE
This PSYC 210 Lecture and Lab class is part of the Psychology House in the First Year Experience Program, which includes ENGL 100 (#27871), PSYC 101 (#20504), PSCY 210 LAB, and READ 101 (#30187). To learn more about FYE and to enroll in this house, please visit <a href="https://www.cerritos.edu/lcp/fye.htm">https://www.cerritos.edu/lcp/fye.htm</a> .					Note: There is no on campus orientation; course is 100% online. Instructor will email students with course information on the first day of the semester. Information will also be posted in Canvas, available through the Cerritos College website. Students must be online by midnight of the first day of class. Waitlist students will be emailed by instructor if they can be added.				
	11:00-12:20PM	TTh	Beas,V	REMOTE	Class# 29731 meets 08/17/2020-10/16/2020				
29106	12:30- 2:00PM	MW	Ramdass,J	REMOTE	<b>PSYC 273 - 3.0 UNITS MENTAL HEALTH WORKER FIELD EXPERIENCE</b>				
	2:00- 3:20PM	MW	Ramdass,J	REMOTE	Transferable to CSU				
29269	3:30- 5:00PM	MW	Burgwin,M	REMOTE	Prerequisite: INST 151, INST 152, PSYC 101, and PSYC 271, with a grade of "C" or higher or "Pass". Corequisite: INST 272 with a grade of "C" or higher or "Pass".				
	<b>5:00- 6:20PM</b>	<b>MW</b>	Burgwin,M	REMOTE	<b>30387</b>	<b>5:00- 5:50PM</b>	<b>Th</b>	Sanserino,A	REMOTE
30663	3.0 HRS ARR	(OL)	Knapp,M	ONLINE		+ 6.0 HRS ARR		Sanserino,A	
	+ 3.0 HRS ARR	(OL)	Knapp,M	ONLINE					
<b>PSYC 220 - 4.0 UNITS RESEARCH METHODS</b>					<b>RADIO - TELEVISION</b>				
Transferable to UC, CSU (CAN PSY 8)					<b>RTV 151 - 3.0 UNITS MOTION PICTURES, RADIO, AND TELEVISION</b>				
Prerequisite: PSYC 101 and PSYC 210 or equivalent with a grade of "Pass" or "C" or higher.					Transferable to CSU				
Recommendation: ENGL 52 or equivalent with a grade of "Pass" or "C" or higher.					Prerequisite: INST 151, INST 152, PSYC 101, and PSYC 271, with a grade of "C" or higher or "Pass".				
<b>25495</b>	<b>6:30- 8:00PM</b>	<b>MW</b>	Munoz,C	REMOTE	21430	3.0 HRS ARR	(OL)	Piotrowski,C	ONLINE
	<b>8:00- 9:20PM</b>	<b>MW</b>	Munoz,C	REMOTE	28515	3.6 HRS ARR	(OL)	Piotrowski,C	ONLINE
27002	12:30- 2:00PM	TTh	Graham,T	REMOTE	Class# 28515 meets 09/08/2020-12/18/2020				
	2:00- 3:20PM	TTh	Graham,T	REMOTE	<b>RTV 152 - 3.0 UNITS INTRODUCTION TO BROADCASTING</b>				
<b>30027</b>	<b>6:30- 8:00PM</b>	<b>TTh</b>	Garcia,A	REMOTE	Transferable to CSU				
	<b>8:00- 9:20PM</b>	<b>TTh</b>	Garcia,A	REMOTE	21373	3.0 HRS ARR	(OL)	Edquist,A	ONLINE
30385	3.0 HRS ARR	(OL)	St. John,H	ONLINE					
	+ 3.0 HRS ARR	(OL)	St. John,H	ONLINE					
<b>PSYC 241 - 3.0 UNITS INTRODUCTION TO PSYCHOBIOLOGY</b>									
Transferable to UC, CSU									
Prerequisite: PSYC 101 or equivalent with a grade of "C" or higher or "Pass."									
20518	3.0 HRS ARR	(OL)	Adams,B	ONLINE					
20519	6.0 HRS ARR	(OL)	Pozos Flores,H	ONLINE					
Note: There is no on campus orientation. Orientation is done online and must be done on the first day of class. Instructor will email students with course information one week prior to the start of the semester. All classwork is done online. Email <a href="mailto:rlewellen@cerritos.edu">rlewellen@cerritos.edu</a>									
Class# 20519 meets 10/19/2020-12/18/2020									
<b>PSYC 245 - 3.0 UNITS DRUGS AND BEHAVIOR</b>									
Transferable to UC, CSU									
25994	3.6 HRS ARR	(OL)	Pozos Flores,H	ONLINE					
Class# 25994 meets 09/08/2020-12/17/2020									
<b>PSYC 251 - 3.0 UNITS DEVELOPMENTAL PSYCHOLOGY</b>									
Transferable to UC, CSU									
20521	3.0 HRS ARR	(OL)	Foley-Soulakis,S	ONLINE					
21280	3.0 HRS ARR	(OL)	Adams,B	ONLINE					
21424	2:00- 3:15PM	TTh	Nguyen,K	REMOTE					
22022	3.0 HRS ARR	(OL)	Sandoval,C	ONLINE					
24473	11:00-12:15PM	TTh	Nguyen,K	REMOTE					
<b>25995</b>	<b>6:30- 9:20PM</b>	<b>T</b>	Jasso,A	REMOTE					
<b>27280</b>	<b>5:00- 6:15PM</b>	<b>MW</b>	Foley-Soulakis,S	REMOTE					

If a class displays as **REMOTE** in the schedule, students will be expected to log into the class at a specified day/time (e.g., MW 8-9:15am). If the class displays as **ONLINE** in the schedule, students are permitted to log into the class whenever they are available to complete coursework by the established deadlines.

Students not in attendance or late for the first class meeting are subject to drop.

Class#	Time	Day	Instructor	Room	Class#	Time	Day	Instructor	Room
--------	------	-----	------------	------	--------	------	-----	------------	------

## READING

### READ 101 - 3.0 UNITS READING AND LEARNING STRATEGIES FOR COLLEGE SUCCESS

Transferable to UC, CSU

30185	3.0 HRS ARR	(OL)	Helberg,B	ONLINE
Mandatory Orientation: Instructor will contact enrolled students before the start of the semester.				
30653	3.0 HRS ARR	(OL)	Helberg,B	ONLINE
30654	3.0 HRS ARR	(OL)	Paige,M	ONLINE
30655	3.0 HRS ARR	(OL)	Paige,M	ONLINE
30656	3.0 HRS ARR	(OL)	Belroy,B	ONLINE
30657	3.0 HRS ARR	(OL)	Paige,M	ONLINE
30658	3.0 HRS ARR	(OL)	Belroy,B	ONLINE
30659	3.0 HRS ARR	(OL)	Helberg,B	ONLINE
30660	3.0 HRS ARR	(OL)	Helberg,B	ONLINE
30661	3.0 HRS ARR	(OL)	Paige,M	ONLINE
29629	3.6 HRS ARR	(OL)	Smith,H	ONLINE
Class# 29629 meets 09/08/2020-12/18/2020				
30184	3.6 HRS ARR	(OL)	Belroy,B	ONLINE
Class# 30184 meets 09/08/2020-12/18/2020				
30186	3.6 HRS ARR	(OL)	Helberg,B	ONLINE
Class# 30186 meets 09/08/2020-12/18/2020				
30187	3.6 HRS ARR	(OL)	Belroy,B	ONLINE
This READ 101 class is part of the Psychology House in the First Year Experience Program, which includes ENGL 100 (#27871), PSYC 101 (#20504), PSYC 210 (#29104), and PSCY 210 LAB. To learn more about FYE and to enroll in this house, please visit <a href="https://www.cerritos.edu/lcp/fye.htm">https://www.cerritos.edu/lcp/fye.htm</a> . Class# 30187 meets 09/08/2020-12/18/2020				

### READ 200 - 3.0 UNITS ANALYSIS AND CRITICAL READING

Transferable to UC, CSU

Prerequisite: Completion of English 100 or equivalent with a grade of "C" or "Pass or higher and READ 54 or READ 97 or equivalent with a grade of "C" or "Pass" or higher or completion of the reading Placement Process with a score of "Reading Exempt."

21653	3.0 HRS ARR	(OL)	Belroy,B	ONLINE
Mandatory Orientation: Instructor will contact enrolled students before the start of the semester.				
25492	3.0 HRS ARR	(OL)	Belroy,B	ONLINE
Mandatory Orientation: Instructor will contact enrolled students before the start of the semester.				
24615	3.0 HRS ARR	(OL)	Paige,M	ONLINE
29241	3.0 HRS ARR	(OL)	STAFF	ONLINE
Mandatory Orientation: Instructor will contact enrolled students before the start of the semester.				
30407	3.0 HRS ARR	(OL)	Paige,M	ONLINE
30408	3.0 HRS ARR	(OL)	Helberg,B	ONLINE
30652	3.0 HRS ARR	(OL)	Paige,M	ONLINE
MANDATORY ORIENTATION: Instructor will contact enrolled students before the start of the semester.				

## REAL ESTATE

### RE 52 - 3.0 UNITS MORTGAGE LOAN BROKERING AND LENDING

Not Transferable

Recommendation: RE 101 or equivalent with a grade of Pass or "C" or higher.

26110	7:00-10:30PM	M	Hupp,S	REMOTE
-------	--------------	---	--------	--------

Class# 26110 meets 09/14/2020-12/14/2020

### RE 101 - 3.0 UNITS REAL ESTATE PRINCIPLES

Transferable to CSU

21961	3.0 HRS ARR	(OL)	Brady,M	ONLINE
21962	3.0 HRS ARR	(OL)	Brady,M	ONLINE
Note: For orientation go to <a href="http://www.cerritos.edu/mebrady">www.cerritos.edu/mebrady</a>				
21971	3.6 HRS ARR	(OL)	Cherry,M	ONLINE
Note: For orientation go to <a href="http://www.cerritos.edu/mebrady">www.cerritos.edu/mebrady</a>				
Class# 21971 meets 09/08/2020-12/18/2020				
27450	6.0 HRS ARR	(OL)	Brady,M	ONLINE
Note: For orientation go to <a href="http://www.cerritos.edu/mebrady">www.cerritos.edu/mebrady</a>				
Class# 27450 meets 10/19/2020-12/18/2020				

### RE 120 - 3.0 UNITS REAL ESTATE FINANCE

Transferable to CSU

Recommendation: RE 101 or equivalent with a grade of Pass or "C" or higher.

24005	3.0 HRS ARR	(OL)	Cherry,M	ONLINE
-------	-------------	------	----------	--------

### RE 125 - 3.0 UNITS LEGAL ASPECTS OF REAL ESTATE

Transferable to CSU

Recommendation: RE 101 or LAW 111 or equivalent with a grade of Pass or "C" or higher.

30030	7:00- 9:50PM	T	Carranza,J	REMOTE
-------	--------------	---	------------	--------

### RE 130 - 3.0 UNITS REAL ESTATE PRACTICE

Transferable to CSU

23871	3.0 HRS ARR	(OL)	Brady,M	ONLINE
21972	3.6 HRS ARR	(OL)	Bird,W	ONLINE

Note: For orientation go to the canvas website  
Class# 21972 meets 09/08/2020-12/18/2020

### RE 140 - 3.0 UNITS REAL ESTATE PROPERTY MANAGEMENT

Transferable to CSU

21966	7:00- 9:50PM	Th	Cicino,M	REMOTE
-------	--------------	----	----------	--------

### RE 157 - 3.0 UNITS REAL ESTATE INVESTMENTS

Transferable to CSU

24431	3.0 HRS ARR	(OL)	Hill,C	ONLINE
-------	-------------	------	--------	--------

### RE 172 - 2.0 UNITS REAL ESTATE OCCUPATIONAL WORK EXPERIENCE/CAREER INTERNSHIP

Transferable to CSU

21968	6:00- 6:50PM	T	Brady,M	REMOTE
29637	8:00- 8:50AM	W	Brady,M	REMOTE

### RE 173 - 3.0 UNITS REAL ESTATE OCCUPATIONAL WORK EXPERIENCE/CAREER INTERNSHIP

Transferable to CSU

21969	6:00- 6:50PM	T	Brady,M	REMOTE
29638	8:00- 8:50AM	W	Brady,M	REMOTE

### RE 174 - 4.0 UNITS REAL ESTATE OCCUPATIONAL WORK EXPERIENCE/CAREER INTERNSHIP

Transferable to CSU

21970	6:00- 6:50PM	T	Brady,M	REMOTE
29639	8:00- 8:50AM	W	Brady,M	REMOTE

## SOCIOLOGY

### SOC 101 - 3.0 UNITS INTRODUCTORY SOCIOLOGY PRINCIPLES

Transferable to UC, CSU (CAN SOC 2)

20550	3.6 HRS ARR	(OL)	Holzgang,A	ONLINE
-------	-------------	------	------------	--------

30 seats in this class are reserved for the FYE Health Occupations House Learning Community, which includes COUN 200 #22518, ENGL 100 #20205, MATH 112 #20340, and MATH 5 #29063. To enroll in the learning community, please complete this contract [http://cms.cerritos.edu/lcp/FYE\\_Contract\\_Page.htm](http://cms.cerritos.edu/lcp/FYE_Contract_Page.htm).

Class# 20550 meets 08/17/2020-11/27/2020				
21787	3.6 HRS ARR	(OL)	Acosta,P	ONLINE
Class# 21787 meets 08/17/2020-11/27/2020				
27443	3.6 HRS ARR	(OL)	Der Mesropian,E	ONLINE
Class# 27443 meets 08/17/2020-11/27/2020				
20549	6.0 HRS ARR	(OL)	Dunn,M	ONLINE
Class# 20549 meets 08/17/2020-10/16/2020				
20553	6.0 HRS ARR	(OL)	Tshako,J	ONLINE
Class# 20553 meets 08/17/2020-10/16/2020				
20554	6.0 HRS ARR	(OL)	Tshako,J	ONLINE
Class# 20554 meets 08/17/2020-10/16/2020				
26427	6.0 HRS ARR	(OL)	Der Mesropian,E	ONLINE
Class# 26427 meets 08/17/2020-10/16/2020				
20829	6.0 HRS ARR	(OL)	Ysais,M	ONLINE
Class# 20829 meets 08/17/2020-10/16/2020				
21607	6.0 HRS ARR	(OL)	Ysais,M	ONLINE
Class# 21607 meets 10/19/2020-12/18/2020				
20555	6.0 HRS ARR	(OL)	Tshako,J	ONLINE
Class# 20555 meets 10/19/2020-12/18/2020				
24480	6.0 HRS ARR	(OL)	Holzgang,A	ONLINE
Class# 24480 meets 10/19/2020-12/18/2020				

If a class displays as **REMOTE** in the schedule, students will be expected to log into the class at a specified day/time (e.g., MW 8-9:15am). If the class displays as **ONLINE** in the schedule, students are permitted to log into the class whenever they are available to complete coursework by the established deadlines.

Students not in attendance or late for the first class meeting are subject to drop.

Class#	Time	Day	Instructor	Room	Class#	Time	Day	Instructor	Room
20552	6.0 HRS ARR	(OL)	Dunn,M	ONLINE	<b>23946</b>	<b>4:30- 6:45PM</b>	<b>MW</b>	Cuesta,Y	REMOTE
	Class# 20552 meets 10/19/2020-12/18/2020					+ 1.0 HRS ARR		Cuesta,Y	REMOTE
27749	6.0 HRS ARR	(OL)	Dunn,M	ONLINE		LAB IS ONE HOUR PER WEEK			
	Class# 27749 meets 10/19/2020-12/18/2020				23948	5.0 HRS ARR	(OL)	Navarro,B	ONLINE
24479	6.0 HRS ARR	(OL)	Brown,K	ONLINE		+ 1.0 HRS ARR	(OL)	Navarro,B	ONLINE
	Orientation: All class information will be available in Canvas. Class# 24479 meets 10/19/2020-12/18/2020					LAB IS ONE HOUR PER WEEK			
<b>SOC 110 - 3.0 UNITS MARRIAGE AND THE FAMILY</b>									
Transferable to UC, CSU									
20830	3.6 HRS ARR	(OL)	Der Mesropian,E	ONLINE	<b>20565</b>	<b>7:00- 9:15PM</b>	<b>MW</b>	Cifuentes,O	REMOTE
	Class# 20830 meets 08/17/2020-11/27/2020					+ 1.0 HRS ARR	(OL)	Cifuentes,O	REMOTE
20556	6.0 HRS ARR	(OL)	Dunn,M	ONLINE		LAB IS ONE HOUR PER WEEK			
	Class# 20556 meets 08/17/2020-10/16/2020				24591	5.0 HRS ARR	(OL)	Navarro,B	ONLINE
27983	6.0 HRS ARR	(OL)	Dunn,M	ONLINE		+ 1.0 HRS ARR	(OL)	Navarro,B	ONLINE
	Class# 27983 meets 10/19/2020-12/18/2020					LAB IS ONE HOUR PER WEEK			
<b>SOC 120 - 3.0 UNITS INTRODUCTION TO HUMAN SEXUALITY</b>									
Transferable to UC, CSU									
<b>29566</b>	<b>7:00- 9:50PM</b>	<b>T</b>	Letelier,Y	REMOTE	20832	5.0 HRS ARR	(OL)	Correa,R	ONLINE
30640	6.0 HRS ARR	(OL)	Smart,B	ONLINE		+ 1.0 HRS ARR	(OL)	Correa,R	ONLINE
	Class# 30640 meets 08/17/2020-10/16/2020					LAB IS ONE HOUR PER WEEK			
20561	6.0 HRS ARR	(OL)	Smart,B	ONLINE	<b>20834</b>	<b>7:00- 9:15PM</b>	<b>TTh</b>	Cifuentes,O	REMOTE
	Class# 20561 meets 10/19/2020-12/18/2020					+ 1.0 HRS ARR		Cifuentes,O	REMOTE
	LAB IS ONE HOUR PER WEEK				26508	2:00- 4:15PM	MW	Linares,M	REMOTE
<b>SOC 201 - 3.0 UNITS SOCIAL PROBLEMS</b>									
Transferable to UC, CSU (CAN SOC 4)									
Recommendation: SOC 101 or equivalent with a grade of Pass or "C" or higher.									
21604	6.0 HRS ARR	(OL)	Tsuhako,J	ONLINE	26981	5.0 HRS ARR	(OL)	Trujillo,Y	ONLINE
	Class# 21604 meets 08/17/2020-10/16/2020					+ 1.0 HRS ARR	(OL)	Trujillo,Y	ONLINE
26208	6.0 HRS ARR	(OL)	Tsuhako,J	ONLINE		LAB IS ONE HOUR PER WEEK			
	Class# 26208 meets 10/19/2020-12/18/2020				28011	8:00-10:15AM	TTh	Vejar,I	REMOTE
	LAB IS ONE HOUR PER WEEK					+ 1.0 HRS ARR		Vejar,I	REMOTE
<b>SOC 202 - 3.0 UNITS GENDER AND SOCIETY</b>									
Transferable to UC, CSU									
Recommendation: SOC 101 or WGS 101 with a grade of "C" or higher or "Pass.									
29128	3.6 HRS ARR	(OL)	Gregg,H	ONLINE	28013	10:30-12:45PM	TTh	Vejar,I	REMOTE
	Orientation: All class information will be available in Canvas. Class# 29128 meets 08/17/2020-11/27/2020					+ 1.0 HRS ARR		Vejar,I	REMOTE
	LAB IS ONE HOUR PER WEEK				29343	5.0 HRS ARR	(OL)	STAFF	ONLINE
27750	6.0 HRS ARR	(OL)	Holzgang,A	ONLINE		+ 1.0 HRS ARR	(OL)	STAFF	ONLINE
	Class# 27750 meets 08/17/2020-10/16/2020					LAB IS ONE HOUR PER WEEK			
30639	6.0 HRS ARR	(OL)	Holzgang,A	ONLINE	27923	5.0 HRS ARR	(OL)	Garcia-Rios,F	ONLINE
	Class# 30639 meets 10/19/2020-12/18/2020					+ 1.0 HRS ARR	(OL)	Garcia-Rios,F	ONLINE
	LAB IS ONE HOUR PER WEEK				Class# 27923 meets 08/22/2020-12/12/2020				
<b>SOC 205 - 3.0 UNITS INTRODUCTION TO SOCIAL RESEARCH METHODS</b>									
Transferable to UC, CSU									
Prerequisite: SOC 101 or ANTH 100 or equivalent with a grade of Pass or "C" or higher.									
Recommendation: ENGL 100 or ENGL 100S or equivalent and MATH 80 or equivalent with a grade of "C" or higher or "Pass".									
26209	3.6 HRS ARR	(OL)	Holzgang,A	ONLINE	<b>20566</b>	<b>4:30- 6:45PM</b>	<b>TTh</b>	Huesca,C	REMOTE
	Class# 26209 meets 09/08/2020-12/18/2020					+ 1.0 HRS ARR		Huesca,C	REMOTE
	LAB IS ONE HOUR PER WEEK				22351	5.0 HRS ARR	(OL)	Garcia-Rios,F	ONLINE
	LAB IS ONE HOUR PER WEEK					+ 1.0 HRS ARR	(OL)	Garcia-Rios,F	ONLINE
	LAB IS ONE HOUR PER WEEK				LAB IS ONE HOUR PER WEEK				
<b>SOC 210 - 3.0 UNITS AMERICAN MINORITY RELATIONS</b>									
Transferable to UC, CSU									
Recommendation: SOC 101 or equivalent with a grade of Pass or "C" or higher.									
24481	6.0 HRS ARR	(OL)	Tsuhako,J	ONLINE	<b>SPAN 102 - 5.0 UNITS ELEMENTARY SPANISH</b>				
	Class# 24481 meets 10/19/2020-12/18/2020				Transferable to UC, CSU (CAN SPAN 4)				
Prerequisite: SPAN 101 or SPAN 103B or SPAN 111 or equivalent with a grade of "C" or higher or "Pass."									
<b>SPAN 111 - 5.0 UNITS ELEMENTARY SPANISH FOR SPANISH SPEAKERS</b>									
Transferable to UC, CSU									
22682	5.0 HRS ARR	(OL)	Hernandez,I	ONLINE		5.0 HRS ARR	(OL)	Hernandez,I	ONLINE
	+ 1.0 HRS ARR	(OL)	Hernandez,I	ONLINE		LAB IS ONE HOUR PER WEEK			
	LAB IS ONE HOUR PER WEEK				20568	8:00-10:15AM	MW	Ugalde,M	REMOTE
	LAB IS ONE HOUR PER WEEK					Targeted for Future Teachers but Open to all Students			
	LAB IS ONE HOUR PER WEEK					+ 1.0 HRS ARR		Ugalde,M	REMOTE
	LAB IS ONE HOUR PER WEEK					LAB IS ONE HOUR PER WEEK			
	LAB IS ONE HOUR PER WEEK					Targeted for Future Teachers but Open to all Students			
	LAB IS ONE HOUR PER WEEK				29345	10:30-12:45PM	MW	Ugalde,M	REMOTE
	LAB IS ONE HOUR PER WEEK					Targeted for Future Teachers but Open to all Students			
	LAB IS ONE HOUR PER WEEK				29346	+ 1.0 HRS ARR		Ugalde,M	REMOTE
	LAB IS ONE HOUR PER WEEK					LAB IS ONE HOUR PER WEEK			
	LAB IS ONE HOUR PER WEEK					Targeted for Future Teachers but Open to all Students			
<b>SPAN 101 - 5.0 UNITS ELEMENTARY SPANISH</b>									
Transferable to UC, CSU (CAN SPAN 2)									
20562	5.0 HRS ARR	(OL)	STAFF	ONLINE		5.0 HRS ARR	(OL)	STAFF	ONLINE
	+ 1.0 HRS ARR	(OL)	STAFF	ONLINE		LAB IS ONE HOUR PER WEEK			
	LAB IS ONE HOUR PER WEEK				20563	5.0 HRS ARR	(OL)	STAFF	ONLINE
	LAB IS ONE HOUR PER WEEK					+ 1.0 HRS ARR	(OL)	STAFF	ONLINE
	LAB IS ONE HOUR PER WEEK					LAB IS ONE HOUR PER WEEK			

## SPANISH

If a class displays as **REMOTE** in the schedule, students will be expected to log into the class at a specified day/time (e.g., MW 8-9:15am). If the class displays as **ONLINE** in the schedule, students are permitted to log into the class whenever they are available to complete coursework by the established deadlines.

Students not in attendance or late for the first class meeting are subject to drop.

Class#	Time	Day	Instructor	Room	Class#	Time	Day	Instructor	Room
<b>SPAN 112 - 5.0 UNITS ELEMENTARY SPANISH FOR SPANISH SPEAKERS</b> Transferable to UC, CSU Prerequisite: SPAN 101 or SPAN 111 or SPAN 103B or equivalent with a grade of Pass or "C" or higher. 20569 5.0 HRS ARR (OL) STAFF ONLINE + 1.0 HRS ARR (OL) STAFF ONLINE LAB IS ONE HOUR PER WEEK					<b>SLP 230 - 1.5 UNITS INTRODUCTION TO AUGMENTATIVE AND ALTERNATIVE COMMUNICATION</b> Transferable to CSU Prerequisite: SLP 125 with a grade of "C" or higher or "Pass." <b>30064 6:00- 7:30PM M</b> Buchheit,A REMOTE Only students admitted to the SLPA program may enroll in this course. <b>6:00- 7:30PM M</b> Buchheit,A REMOTE Only students admitted to the SLPA program may enroll in this course. Students will be added to the class based on providing required documentation for placements. Please see Field Placement requirements on the SLPA webpage at: <a href="https://www.cerritos.edu/slpa">https://www.cerritos.edu/slpa</a> . Class# 30066 meets 09/24/2020-12/10/2020				
<b>SPAN 201 - 5.0 UNITS INTERMEDIATE SPANISH</b> Transferable to UC, CSU (CAN SPAN 8) Prerequisite: SPAN 102 or SPAN 112 or equivalent with a grade of Pass or "C" or higher. 20835 12:30- 2:45PM TTh Ugalde,M REMOTE + 1.0 HRS ARR Ugalde,M REMOTE LAB IS ONE HOUR PER WEEK					<b>SLP 246 - 2.5 UNITS CLINICAL EXPERIENCE II</b> Transferable to CSU Prerequisite: Completion of SLP 235 and SLP 241 with a grade of "C" or better, or equivalent. 30066 4:00- 5:30PM McDonald,S REMOTE + 6.8 HRS ARR McDonald,S REMOTE				
<b>SPAN 223 - 3.0 UNITS SPANISH FOR HEALTH AND MEDICAL CAREERS</b> Transferable to CSU 24593 9:00-12:05PM Sat Bedolla,J REMOTE Class# 24593 meets 08/22/2020-12/12/2020					<b>THEATRE ARTS</b>				
<b>SPAN 245 - 3.0 UNITS INTRODUCTION TO CHICANO/MEXICAN AMERICAN CULTURE</b> Transferable to UC, CSU 20570 3.0 HRS ARR (OL) Arce,C ONLINE 20836 3.0 HRS ARR (OL) Arce,C ONLINE MANDATORY ORIENTATION: All enrolled students must complete the mandatory orientation on Canvas.					<b>TH 101 - 3.0 UNITS INTRODUCTION TO THE THEATRE</b> Transferable to UC, CSU (CAN DRAM 18) 23858 3.0 HRS ARR (OL) Wahlquist,L ONLINE 23432 3.0 HRS ARR (OL) Watanabe-Lonsbury,S ONLINE 25999 3.0 HRS ARR (OL) Hartl,F ONLINE 21290 3.0 HRS ARR (OL) STAFF ONLINE 29455 11:00-12:20PM MW Prell,J REMOTE 23433 4.5 HRS ARR (OL) Walton,E ONLINE Class# 23433 meets 09/28/2020-12/18/2020 26098 3.6 HRS ARR (OL) Sneed,H ONLINE Class# 26098 meets 09/08/2020-12/18/2020 27416 6.0 HRS ARR (OL) Reiter,B ONLINE Note: This is an ONLINE course - all instruction is completed online. No in-person orientation. Please check Canvas for online orientation information and directions for completion (instructor e-mail address: breiter@cerritos.edu). Class# 27416 meets 08/17/2020-10/16/2020 20839 6.0 HRS ARR (OL) Sneed,H ONLINE Class# 20839 meets 10/19/2020-12/18/2020 27417 6.0 HRS ARR (OL) Reiter,B ONLINE Note: This is an ONLINE course - all instruction is completed online. No in-person orientation. Please check Canvas for online orientation information and directions for completion (instructor e-mail address: breiter@cerritos.edu). Class# 27417 meets 10/19/2020-12/18/2020				
<b>SPEECH AND LANGUAGE PATHOLOGY</b>									
Applications for Fall 2021 admission to the Speech-Language Pathology Program are due in the Health Occupations Division Office no later than April 5, 2021. Students must be accepted into the SLPA Program prior to enrolling in SLP 108, SLP 125, SLP 230, and SLP 246. For more information call (562) 860-2451, ext. 2550. Clearance of a criminal background check and/or drugs of abuse testing may be required prior to clinical field experience.									
<b>SLP 101 - 3.0 UNITS INTRODUCTION TO COMMUNICATION DISORDERS</b> Transferable to CSU Recommendation: ENGL 52 or ENGL 72 or ESL 152 or equivalent with a grade of "C" or higher or "Pass", or completion of the assessment/placement process with eligibility for ENGL 100 or ENGL 100S. <b>24198 6:00- 8:50PM M</b> McDonald,S REMOTE					<b>TH 104 - 3.0 UNITS HISTORY AND APPRECIATION OF MUSICAL THEATRE</b> Transferable to UC, CSU 30595 3.0 HRS ARR (OL) Prell,J ONLINE				
<b>SLP 105 - 3.0 UNITS SPEECH AND LANGUAGE DEVELOPMENT IN CHILDREN</b> Transferable to CSU Recommendation: ENGL 52 or ENGL 72 or ESL 152 or equivalent with a grade of "C" or higher or "Pass", or completion of the assessment/placement process with eligibility for ENGL 100 or ENGL 100S. <b>22670 6:00- 8:50PM W</b> Oh,S REMOTE					<b>TH 108 - 3.5 UNITS IMPROVISATION FOR THE THEATRE</b> Transferable to UC, CSU 23639 3.0 HRS ARR (OL) Hartl,F ONLINE				
<b>SLP 108 - 3.0 UNITS INTRODUCTION TO PHONETICS</b> Transferable to CSU <b>30061 5:00- 7:00PM M</b> Oh,S REMOTE Only students admitted to the SLPA program may enroll in this course. <b>7:00- 9:50PM M</b> Oh,S REMOTE Only students admitted to the SLPA program may enroll in this course.					<b>TH 110 - 3.5 UNITS FUNDAMENTALS OF ACTING</b> Transferable to UC, CSU (CAN DRAM 8) 27696 3.6 HRS ARR (OL) Wahlquist,L ONLINE + 2.4 HRS ARR (OL) Wahlquist,L ONLINE Class# 27696 meets 09/08/2020-12/18/2020				
<b>SLP 125 - 5.0 UNITS CHILDHOOD DISORDERS AND TREATMENT</b> Transferable to CSU <b>29282 5:00- 8:50PM T</b> McDonald,S REMOTE PLEASE ENROLL IN LAB SECTION OF YOUR CHOICE. THE LECTURE SECTION #29282 WILL BE AUTOMATICALLY ADDED. <b>29283 6:00- 8:50PM W</b> Buchheit,A REMOTE Only students admitted to the SLPA program may enroll in this course. <b>30063 6:00- 8:50PM Th</b> McDonald,S REMOTE Only students admitted to the SLPA program may enroll in this course.					<b>TH 112 - 3.0 UNITS SCRIPT ANALYSIS</b> Transferable to CSU 30596 3.6 HRS ARR (OL) Reiter,B ONLINE Class# 30596 meets 09/08/2020-12/18/2020				
					<b>TH 123 - 3.0 UNITS STAGE MAKE-UP</b> Transferable to UC, CSU (CAN DRAM 14) NOTE: a material fee of \$85.00 is required for TH 123 28770 1:00- 3:00PM TTh Watanabe-Lonsbury,S REMOTE + 3.0 HRS ARR (OL) Watanabe-Lonsbury,S ONLINE 29607 3:00- 5:20PM MW Watanabe-Lonsbury,S REMOTE + 3.0 HRS ARR (OL) Watanabe-Lonsbury,S ONLINE				

If a class displays as **REMOTE** in the schedule, students will be expected to log into the class at a specified day/time (e.g., MW 8-9:15am). If the class displays as **ONLINE** in the schedule, students are permitted to log into the class whenever they are available to complete coursework by the established deadlines.

Students not in attendance or late for the first class meeting are subject to drop.



Class#	Time	Day	Instructor	Room	Class#	Time	Day	Instructor	Room
--------	------	-----	------------	------	--------	------	-----	------------	------

**TH 130 - 1.0 UNIT REHEARSAL AND PERFORMANCE FOR THE MINOR ROLE**

Transferable to UC, CSU

25135 1.0 HRS ARR (OL) Hartl,F ONLINE  
 AUDITIONS ARE REQUIRED TO ENROLL IN THE FOLLOWING CLASSES: TH 130, 131 and 132. Please e-mail your instructor at HYPERLINK "mailto:fhartl@cerritos.edu" fhartl@cerritos.edu

+ 5.0 HRS ARR (OL) Hartl,F ONLINE  
 Class# 25135 meets 08/17/2020-10/16/2020

25137 1.0 HRS ARR (OL) Reiter,B ONLINE  
 + 5.0 HRS ARR (OL) Reiter,B ONLINE  
 Class# 25137 meets 10/19/2020-12/18/2020

**TH 131 - 2.0 UNITS REHEARSAL AND PERFORMANCE FOR THE SUPPORTING ROLE**

Transferable to UC, CSU

25139 2.0 HRS ARR (OL) Hartl,F ONLINE  
 + 8.0 HRS ARR (OL) Hartl,F ONLINE  
 Class# 25139 meets 08/17/2020-10/16/2020

25141 2.0 HRS ARR (OL) Reiter,B ONLINE  
 + 8.0 HRS ARR (OL) Reiter,B ONLINE  
 Class# 25141 meets 10/19/2020-12/18/2020

**TH 132 - 3.0 UNITS REHEARSAL AND PERFORMANCE FOR THE LEADING ROLES**

Transferable to UC, CSU (CAN DRAM 16)

25133 2.0 HRS ARR (OL) Reiter,B ONLINE  
 +14.0 HRS ARR (OL) Reiter,B ONLINE  
 Class# 25133 meets 10/19/2020-12/18/2020

**TH 133 - 1.0 UNIT STAGE CREW ACTIVITY**

Transferable to UC, CSU

26502 1.0 HRS ARR (OL) Watanabe-Lonsbury,S ONLINE  
 + 5.0 HRS ARR (OL) Watanabe-Lonsbury,S ONLINE  
 Class# 26502 meets 08/17/2020-10/16/2020

**TH 150 - 3.0 UNITS APPRECIATION AND HISTORY OF THE MOTION PICTURE**

Transferable to UC, CSU

23434 3.6 HRS ARR (OL) Campolo,R ONLINE  
 Class# 23434 meets 10/19/2020-12/18/2020

20958 3.6 HRS ARR (OL) Campolo,R ONLINE  
 Class# 20958 meets 09/08/2020-12/18/2020

21291 3.6 HRS ARR (OL) Campolo,R ONLINE  
 Class# 21291 meets 09/08/2020-12/18/2020

27974 6.0 HRS ARR (OL) Campolo,R ONLINE  
 Class# 27974 meets 10/19/2020-12/18/2020

29752 6.0 HRS ARR (OL) Campolo,R ONLINE  
 Class# 29752 meets 10/19/2020-12/18/2020

**TH 151 - 3.0 UNITS MOTION PICTURES, RADIO AND TELEVISION**

Transferable to CSU

20593 3.0 HRS ARR (OL) Piotrowski,C ONLINE  
 28514 3.9 HRS ARR (OL) Piotrowski,C ONLINE  
 Class# 28514 meets 09/14/2020-12/14/2020

**TH 212 - 3.5 UNITS SCENE STUDY**

Transferable to UC, CSU

Prerequisite: TH 110 or equivalent with a grade of Pass or "C" or higher.

29088 3.6 HRS ARR (OL) Reiter,B ONLINE  
 + 2.4 HRS ARR (OL) Reiter,B ONLINE  
 Class# 29088 meets 09/08/2020-12/18/2020

**TH 226 - 2.0 UNITS INTRODUCTION TO SCENIC DESIGN**

Transferable to UC, CSU

30597 1.0 HRS ARR (OL) Ward,D ONLINE  
 + 3.0 HRS ARR (OL) Ward,D ONLINE

**WELDING**

Please read the technical standards relevant to this department at <http://cms.cerritos.edu/technology/standards.htm>

**WELD 49 - 4.0 UNITS WELDING SHOP MATH**

Not Transferable

Recommendation: WELD 100 or equivalent with a grade of Pass or "C" or higher or WELD 120 or equivalent with a grade of Pass or "C" or higher or WELD 130 or equivalent with a grade of Pass or "C" or higher.

23587 4.0 HRS ARR (OL) Nunez,J ONLINE  
 27624 4.0 HRS ARR (OL) Nunez,J ONLINE

**WELD 52 - 4.0 UNITS PIPE WELDING FUNDAMENTALS**

Not Transferable

Prerequisite: WELD 210L or equivalent with a grade of Pass or "C" or higher.  
 Recommendation: Current Los Angeles City or AWS certification for structural steel. NOTE: a material fee of \$100.00 is required for WELD 52

27360 2.0 HRS ARR (OL) Allen Jr.,A ONLINE  
**5:00- 7:50PM TTh** Allen Jr.,A ME 13

The lab portion of this class will be a hybrid - partially on campus & partially online. The class will be divided into two groups. Each group will be on campus partially. You will be contacted by your instructor on which group you will be assigned to.

**WELD 59 - 4.0 UNITS BLUEPRINT READING FOR THE WELDING TRADES**

Not Transferable

Recommendation: WELD 100 or equivalent with a grade of Pass or "C" or higher or WELD 120 or equivalent with a grade of Pass or "C" or higher or WELD 130 or equivalent with a grade of Pass or "C" or higher.

23588 4.0 HRS ARR (OL) Nunez,J ONLINE  
 27357 4.0 HRS ARR (OL) Nunez,J ONLINE

**WELD 100 - 2.5 UNITS WELDING FUNDAMENTALS**

Transferable to CSU

NOTE: a material fee of \$100.00 is required for WELD 100

30611 2.0 HRS ARR (OL) Nunez,J ONLINE  
**6:00- 7:50PM MW** Figueroa,M ME 13

The lab portion of this class will be a hybrid - partially on campus & partially online. The class will be divided into two groups. Each group will be on campus partially. You will be contacted by your instructor on which group you will be assigned to.

30689 2.0 hrs arr (OL) Allen, A. ONLINE  
 8:00-9:50am F Allen, A. ME 13  
**5:00- 6:50PM F** Nunez,J ME 13

**WELD 120 - 5.0 UNITS BEGINNING ARC WELDING**

Transferable to CSU

Recommendation: WELD 100 with a grade of Pass or "C" or higher or concurrent enrollment or appropriate work experience. NOTE: a material fee of \$100.00 is required for WELD 120

20843 4.0 HRS ARR (OL) Figueroa,M ONLINE

The lab portion of this class will be a hybrid - partially on campus & partially online. The class will be divided into two groups. Each group will be on campus partially. You will be contacted by your instructor on which group you will be assigned to.

25440 4.0 HRS ARR (OL) Foral,J ONLINE  
 9:00-10:50AM MW Foral,J ME 13

The lab portion of this class will be a hybrid - partially on campus & partially online. The class will be divided into two groups. Each group will be on campus partially. You will be contacted by your instructor on which group you will be assigned to.

**WELD 130 - 5.0 UNITS GAS TUNGSTEN ARC WELDING FUNDAMENTALS**

Transferable to CSU

Recommendation: WELD 100 or WELD 120 or equivalent with a grade of Pass or "C" or higher or concurrent enrollment or appropriate work experience. NOTE: a material fee of \$100.00 is required for WELD 130

26338 4.0 HRS ARR (OL) Tait,M ONLINE  
 10:00-11:50AM TTh Tait,M ME 13

The lab portion of this class will be a hybrid - partially on campus & partially online. The class will be divided into two groups. Each group will be on campus partially. You will be contacted by your instructor on which group you will be assigned to.

If a class displays as **REMOTE** in the schedule, students will be expected to log into the class at a specified day/time (e.g., MW 8-9:15am). If the class displays as **ONLINE** in the schedule, students are permitted to log into the class whenever they are available to complete coursework by the established deadlines.

Students not in attendance or late for the first class meeting are subject to drop.



Class#	Time	Day	Instructor	Room	Class#	Time	Day	Instructor	Room
<b>WGS 115 - 3.0 UNITS GENDER, COMMUNICATION, AND THE DIGITAL REVOLUTION</b> Transferable to UC, CSU Prerequisite: Completion of at least one of these courses or an equivalent course: COMM 60, ENGL 72, ESL 152, READ 54, READ 97 or completion of the English or Reading assessment/placement process with eligibility for ENGL 100 or ENGL 100S.					<div style="background-color: #8B4513; color: white; padding: 10px; text-align: center;"> <h2 style="margin: 0;">WOODWORKING MANUFACTURING TECHNOLOGY</h2> </div> <p>Please read the technical standards relevant to this department at <a href="http://cms.cerritos.edu/technology/standards.htm">http://cms.cerritos.edu/technology/standards.htm</a></p>				
29109	6.0 HRS ARR	(OL)	Rosenfeld,K	ONLINE					
28198	6.0 HRS ARR	(OL)	Rosenfeld,K	ONLINE	20602	2.5 HRS ARR	(OL)	Fortner,A	ONLINE
<b>WGS 118 - 3.0 UNITS HISTORY OF WOMEN IN VISUAL ARTS</b> Transferable to UC, CSU Recommendation: ENGL 52 or ENGL 72 or ESL 152 or equivalent with a grade of "C" or higher or "Pass" or completion of the English assessment/placement process with a score eligible for ENGL 100 or ENGL 100S; and satisfactory completion of READ 54 or READ 97 or READ 102 or equivalent with a grade of "C" or higher or "Pass" or completion of the Reading assessment/placement process with a score of "Reading Exempt."					Targeted for Future Teachers but Open to all Students 10:00-11:50AM W Fortner,A (HYBRID) WD 14 The lab portion of this class will be a hybrid - partially on campus & partially online. The class will be divided into two groups. Each group will be on campus partially. You will be contacted by your instructor on which group you will be assigned to. Targeted for Future Teachers but Open to all Students				
29111	3.6 HRS ARR	(OL)	Vitela,L	ONLINE	20849	2.5 HRS ARR	(OL)	Sanchez,C	ONLINE
<b>WGS 140 - 3.0 UNITS INTRODUCTION TO LGBT STUDIES</b> Transferable to UC, CSU Recommendation: ENGL52, or ENGL 72 or ESL 152 or equivalent with a grade of "C" or higher or "Pass."					8:00- 9:50PM F Sanchez,C (HYBRID) WD 14 The lab portion of this class will be a hybrid - partially on campus & partially online. The class will be divided into two groups. Each group will be on campus partially. You will be contacted by your instructor on which group you will be assigned to.				
30390	3.0 HRS ARR	(OL)	Kayser,L	ONLINE	<b>WMT 102 - 4.0 UNITS INTRODUCTION TO SOLID WOOD CASEGOODS</b> Transferable to CSU Prerequisite: Completion of WMT 101 with a grade of "C" or higher or "Pass." NOTE: a material fee of \$20.00 is required for WMT 102				
<b>WGS 202 - 3.0 UNITS GENDER AND SOCIETY</b> Transferable to UC, CSU					29265 2.5 HRS ARR (OL) Fortner,A ONLINE 8:15-10:50AM TTh Fortner,A (HYBRID) WD 14 The lab portion of this class will be a hybrid - partially on campus & partially online. The class will be divided into two groups. Each group will be on campus partially. You will be contacted by your instructor on which group you will be assigned to.				
29112	3.6 HRS ARR	(OL)	Gregg,H	ONLINE	<b>WMT 103 - 4.0 UNITS INTRODUCTION TO TABLES</b> Transferable to CSU Prerequisite: Completion of WMT 101 with a grade of "C" or higher or "Pass." NOTE: a material fee of \$20.00 is required for WMT 103				
27753	6.0 HRS ARR	(OL)	Holzgang,A	ONLINE	20850	2.5 HRS ARR	(OL)	Stammerjohn,C	ONLINE
30638	6.0 HRS ARR	(OL)	Holzgang,A	ONLINE	2:15- 4:50PM TTh Stammerjohn,C (HYBRID) WD 14 The lab portion of this class will be a hybrid - partially on campus & partially online. The class will be divided into two groups. Each group will be on campus partially. You will be contacted by your instructor on which group you will be assigned to.				
<b>WGS 206 - 3.0 UNITS WOMEN IN THE GLOBAL ECONOMY</b> Transferable to UC, CSU Recommendation: ENGL 100 or ENGL 100S or equivalent with a grade of "C" or higher or "Pass".					30620 2.5 HRS ARR (OL) Thornbury,R ONLINE 10:50- 4:50PM F Thornbury,R (HYBRID) WD 13 The lab portion of this class will be a hybrid - partially on campus & partially online. The class will be divided into two groups. Each group will be on campus partially. You will be contacted by your instructor on which group you will be assigned to.				
29640	3.6 HRS ARR	(OL)	De Los Rios,K	ONLINE	<b>WMT 130 - 3.0 UNITS FURNITURE DESIGN</b> Transferable to CSU NOTE: a material fee of \$20.00 is required for WMT 130				
<b>WGS 207 - 3.0 UNITS WOMEN AND MEDIA</b> Transferable to UC, CSU Prerequisite: ENGL 52 or ENGL 72 or ESL 152 or equivalent with a grade of "C" or higher, or "Pass," or completion of the English assessment/placement process with eligibility for ENGL 100 or ENGL 100S.					30355 2.0 HRS ARR (OL) Foat,R ONLINE + 4.0 HRS ARR (OL) Foat,R ONLINE				
29113	6.0 HRS ARR	(OL)	Trager,J	ONLINE	<b>WMT 151 - 4.0 UNITS INTRODUCTION TO FACEFRAME CABINETMAKING</b> Transferable to CSU NOTE: a material fee of \$20.00 is required for WMT 151				
<b>WGS 208 - 3.0 UNITS LEADERSHIP FOR WOMEN IN BUSINESS</b> Transferable to CSU					21115 2:15- 4:50PM MW Fortner,A (HYBRID) WD 15 21470 2.5 HRS ARR (OL) Fortner,A ONLINE Note: The lab portion of this class will be a hybrid - partially on campus & partially online. The class will be divided into two groups. Each group will be on campus partially. You will be contacted by your instructor on which group you will be assigned to.				
26384	6.0 HRS ARR	(OL)	Livingston,B (Women's Studies)	ONLINE					
26385	6.0 HRS ARR	(OL)	Livingston,B (Women's Studies)	ONLINE					
26386	6.0 HRS ARR	(OL)	Livingston,B (Women's Studies)	ONLINE					

If a class displays as **REMOTE** in the schedule, students will be expected to log into the class at a specified day/time (e.g., MW 8-9:15am). If the class displays as **ONLINE** in the schedule, students are permitted to log into the class whenever they are available to complete coursework by the established deadlines.

Students not in attendance or late for the first class meeting are subject to drop.

Class#	Time	Day	Instructor	Room	Class#	Time	Day	Instructor	Room
30353	2.5 HRS ARR 10:50- 4:50PM	(OL) Sat	Wood,J Wood,J (HYBRID)	ONLINE WD 15					
<p>The lab portion of this class will be a hybrid - partially on campus &amp; partially online. The class will be divided into two groups. Each group will be on campus partially. You will be contacted by your instructor on which group you will be assigned to.</p> <p>Class# 30353 meets 08/22/2020-12/12/2020</p> <p><b>WMT 153 - 4.0 UNITS 32MM SYSTEM OF CABINETMAKING</b> Transferable to CSU Prerequisite: Completion of WMT 151 or equivalent with a grade of "C" or higher or "Pass." NOTE: a material fee of \$20.00 is required for WMT 153</p>									
30622	2.5 HRS ARR 7:15- 9:50PM	(OL) TTh	Krause,P Krause,P (HYBRID)	ONLINE WD 15					
<p>The lab portion of this class will be a hybrid - partially on campus &amp; partially online. The class will be divided into two groups. Each group will be on campus partially. You will be contacted by your instructor on which group you will be assigned to.</p> <p><b>WMT 183 - 3.0 UNITS SKETCHUP FOR WOODWORKERS</b> Transferable to CSU Prerequisite: WMT 100 or WMT 101 or WMT 151 or equivalent with a grade of "C" or higher or "Pass." Recommendation: Students should have basic knowledge of computers and file management. NOTE: a material fee of \$5.00 is required for WMT 183</p>									
30618	3.0 HRS ARR + 1.0 HRS ARR	Stammerjohn,C	Stammerjohn,C	ONLINE ONLINE					
<p>The lab portion of this class will be a hybrid - partially on campus &amp; partially online. The class will be divided into two groups. Each group will be on campus partially. You will be contacted by your instructor on which group you will be assigned to.</p> <p><b>WMT 184 - 3.0 UNITS INTRODUCTION TO DIGITAL FABRICATION</b> Transferable to CSU</p>									
30361	3.0 HRS ARR 2:15- 4:50PM	(OL) TTh	Foat,R Foat,R (HYBRID)	ONLINE WD 1					
<p>The lab portion of this class will be a hybrid - partially on campus &amp; partially online. The class will be divided into two groups. Each group will be on campus partially. You will be contacted by your instructor on which group you will be assigned to.</p> <p><b>WMT 201 - 4.0 UNITS WOODWORKING WITH HAND TOOLS</b> Transferable to CSU NOTE: a material fee of \$10.00 is required for WMT 201</p>									
25457	2.5 HRS ARR 7:15- 9:50PM	(OL) MW	Stammerjohn,C Stammerjohn,C (HYBRID)	ONLINE WD 13					
<p>The lab portion of this class will be a hybrid - partially on campus &amp; partially online. The class will be divided into two groups. Each group will be on campus partially. You will be contacted by your instructor on which group you will be assigned to.</p>									

## ZOOLOGY

<p><b>ZOOL 120 - 4.0 UNITS INTRODUCTION TO ANIMAL BIOLOGY</b> Transferable to UC, CSU Prerequisite: ENGL 52 or ENGL 72 or ESL 152 or equivalent with a grade of "C" or higher or "Pass" or completion of the English assessment/placement process with a score eligible for ENGL 100 or ENGL 100S.</p>									
20608	8:00- 8:45AM 9:00-11:50AM	TTh TTh	Rodela,M Rodela,M	REMOTE REMOTE					
<p>Tests will be given in Canvas using Proctorio or Respondus which requires access to a webcam and microphone. Canvas will be used for ConferZoom and e-mail.</p>									

If a class displays as **REMOTE** in the schedule, students will be expected to log into the class at a specified day/time (e.g., MW 8-9:15am). If the class displays as **ONLINE** in the schedule, students are permitted to log into the class whenever they are available to complete coursework by the established deadlines.

Students not in attendance or late for the first class meeting are subject to drop.

## SHORT TERM CLASSES

Ticket#	Course#	Description	Ticket#	Course#	Description
<b>1st THREE WEEKS: 08/17/2020-09/04/2020</b>			<b>2nd SIX WEEKS: 09/28/2020-11/06/2020</b>		
30498	COUN 101B	Educational Planning	30692	ENGL 100	Freshman Composition
30504	COUN 101B	Educational Planning	30687	MATH 112	Elementary Statistics
30514	COUN 101B	Educational Planning	30686	MATH 5	Math Learning Strategies
30518	COUN 101B	Educational Planning	20904	HO 54	Medical Laboratory Skills
30522	COUN 101B	Educational Planning	30554	HO 54	Medical Laboratory Skills
30500	COUN 101B	Educational Planning	29277	COUN 101A	Orientation to College
30527	COUN 101B	Educational Planning	30315	COUN 101B	Educational Planning
30515	COUN 101B	Educational Planning	23681	COUN 101A	Orientation to College
30519	COUN 101B	Educational Planning	29825	DANC 100	Dance Appreciation
30523	COUN 101B	Educational Planning	<b>SEVEN WEEKS: 10/24/2020-12/05/2020</b>		
30525	COUN 101B	Educational Planning	29261	MTT 168	Adv Comp Asst Inspc Verisurf
30507	COUN 101B	Educational Planning	<b>1st NINE WEEKS: 08/17/2020-10/16/2020</b>		
30513	COUN 101B	Educational Planning	28932	AB 66	Lettering, Striping and Design
30517	COUN 101B	Educational Planning	28936	AB 80	Autobody Customer Service
30501	COUN 101B	Educational Planning	21945	ACCT 60	Quickbooks Accounting
<b>2nd THREE WEEKS: 09/12/2020-09/26/2020</b>			21950	ACCT 61	Turbo Tax Accounting
30528	COUN 101B	Educational Planning	28147	ACLR 101	Increasing Your Access Potential
30516	COUN 101B	Educational Planning	23870	ANTH 115	Physical Anthropology
30520	COUN 101B	Educational Planning	30047	ART 124	Introduction to Media Studies
30524	COUN 101B	Educational Planning	28986	ASTR 102	Introduction Astron Stars Univrse
30526	COUN 101B	Educational Planning	20888	AUTO 73	Auto Occupational Work Experience
30510	COUN 101B	Educational Planning	20889	AUTO 73	Auto Occupational Work Experience
30531	COUN 101B	Educational Planning	20646	BA 100	Fundamentals of Business
<b>3rd THREE WEEKS: 09/28/2020-10/14/2020</b>			26210	BA 100	Fundamentals of Business
30505	COUN 101B	Educational Planning	27445	BA 100	Fundamentals of Business
30502	COUN 101B	Educational Planning	22849	BA 101	International Business
30508	COUN 101B	Educational Planning	26992	BA 104	Managing Cultural Diversity
30511	COUN 101B	Educational Planning	24099	BA 106	Human Resource Management
30529	COUN 101B	Educational Planning	26047	BA 106	Human Resource Management
30532	COUN 101B	Educational Planning	26997	BA 106	Human Resource Management
<b>4th THREE WEEKS: 10/24/2020-11/07/2020</b>			23570	BA 107	Human Relations In Bus
30530	COUN 101B	Educational Planning	23571	BA 107	Human Relations In Bus
30512	COUN 101B	Educational Planning	23770	BA 107	Human Relations In Bus
30509	COUN 101B	Educational Planning	29447	BA 107	Human Relations In Bus
30506	COUN 101B	Educational Planning	27767	BA 109	Human Resource Development
30503	COUN 101B	Educational Planning	27421	BA 110	Advertising
30533	COUN 101B	Educational Planning	22851	BA 113	Legal Environment of Business
<b>FIVE WEEKS: 11/18/2020-12/16/2020</b>			20098	BA 114	Marketing
30676	COUN 101B	Educational Planning	22854	BA 114	Marketing
<b>1st SIX WEEKS: 08/17/2020-09/25/2020</b>			27447	BA 114	Marketing
21346	BCOT 62	Computer Keyboarding	20651	BA 115	Management-Business
21488	BCOT 63	Keyboarding Speed/Control	23573	BA 115	Management-Business
30696	COMM 100	Introduction to Communication Studies	24985	BA 115	Management-Business
30691	ENGL 100	Freshman Composition	27426	BA 115	Management-Business
30312	COUN 101B	Educational Planning	22852	BA 118	Retail Management
20945	HO 53	Electrocardiography	24412	BA 118	Retail Management
30553	HO 53	Electrocardiography	26215	BA 118	Retail Management
30314	COUN 101B	Educational Planning	25590	BA 120	Management-Accountant & Internal Control
			26216	BA 120	Management-Accountant & Internal Control
			20099	BA 121	Sales
			22553	BA 132	Computer Applications/Managers
			22554	BA 132	Computer Applications/Managers
			25158	BA 132	Computer Applications/Managers
			26545	BA 132	Computer Applications/Managers
			21774	BA 153	Small Business Management
			22287	BA 156	Motivational Skills/Managers
			23771	BA 156	Motivational Skills/Managers
			22661	BA 157	Principles of Public Relations
			23586	BA 205	Organizational Leadership
			22549	BA 208	Leadership for Women in Bus
			21357	BCOT 112	Microsoft Word
			25596	BCOT 113	Microsoft Excel
			29114	BCOT 96	Microsoft PowerPoint
			30536	CA 55	Fund Of Responsible Alcohol Service

Attendance is mandatory (including wait listed students). Failure to appear will jeopardize your official enrollment.

For a complete listing of all classes offered see pages #-#

## SHORT TERM CLASSES

Ticket#	Course#	Description	Ticket#	Course#	Description
20673	CIS 101	Introduction Computer Info Systms	29109	WGS 115	Gender,Comm, & the Digital Revolution
24307	CIS 170A	Networking Fundamentals			
27672	CIS 58A	PC Operating System A+ Certification	27753	WGS 202	Gender and Society
20887	COMM 100	Introduction to Communication Studies	26384	WGS 208	Leadership for Women in Bus
29245	COMM 100	Introduction to Communication Studies	26971	ESL 120	Prep For Col Writing-NonEngl
25632	COMM 110	Intercultural Communication	20890	CA 101	Introduction/Food Service Safety-Sanitation
29249	COMM 115	Gender,Communication, & Digital Revolution	27964	COUN 101B	Educational Planning
30194	COMM 130	Public Speaking	27965	COUN 101B	Educational Planning
27128	COS 53	Adv Cosmet Manipulation	27966	COUN 101B	Educational Planning
22217	COS 60A	Introduction Cosmetology I	27967	COUN 101B	Educational Planning
22221	COS 61A	Intermed Cosmetology I	27968	COUN 101B	Educational Planning
22225	COS 62A	Advanced Cosmetology I	27969	COUN 101B	Educational Planning
29419	COUN 101C	Navigating the Transfer Proces	27971	COUN 101B	Educational Planning
20133	COUN 200	Success College and Career	23662	PHAR 55	Pharmacy Introduction
22306	COUN 200	Success College and Career	23666	PHAR 56	Pharmacy Skills Lab Introduction
22679	DANC 100	Dance Appreciation	30563	PHAR 56	Pharmacy Skills Lab Introduction
27555	DANC 100	Dance Appreciation	30564	PHAR 56	Pharmacy Skills Lab Introduction
28158	DANC 100	Dance Appreciation	22194	PTA 129	PT Aging and Integumentary
28735	DANC 100	Dance Appreciation	20893	HO 55	Phlebotomy Procedures
22293	EDT 110	Introduction To Ed Technology	30555	HO 55	Phlebotomy Procedures
24172	EDT 110	Introduction To Ed Technology	20894	HO 56	Medication Calculations
30024	EDT 135	Slide Presentation Software	29075	NRSRG 48T	Elective Nursing - Tutorial
29099	EDT 50	Prep for Online Learning	21404	NRSRG 213B	Major Drugs and Nursing II
21781	ENGL 100	Freshman Composition	23669	PHAR 57	Pharmacy Operations I
22346	ENGL 100	Freshman Composition	27011	ECON 201	Principles of Macroeconomics
22452	ENGL 100	Freshman Composition	27013	ECON 201M	Principles of Macroeconomics
24115	ENGL 100	Freshman Composition	30137	ENGL 100	Freshman Composition
24542	ENGL 100	Freshman Composition	22128	MUS 104B	History of Rock Music
28817	ENGL 100	Freshman Composition	29312	PEX 106	Adapted Aquatic Exercise
30393	ENGL 100	Freshman Composition	29338	PEX 188	Tennis, Introduction
30395	ENGL 100	Freshman Composition	29340	PEX 189	Tennis, Beginning
30080	ENGL 100S	Enhanced Freshman Composition	30139	ENGL 100	Freshman Composition
21474	ENGL 103	Critical/Argumentative Wrt	29219	ESL 12	ESL Pronunciation
26136	ENGT 117	Geometrical Tolerancing	30412	PEX 100	Fitness for Student's with Dis
29363	ESCI 106	Weather and Climate	30416	PEX 102	Adapted Cardiovascular Exer
25626	ESL 11	ESL Reading 1	25559	PEX 105	Adapted Swimming
27658	GEOG 105	World Regional Geography	29660	PEX 106A	Adapted Aquatic Group Fitness
20257	HED 100	Contemp Health Problems	24674	ATH 205LA	Basketball, Women, Off Season
24493	HED 100	Contemp Health Problems	21398	AUTO 121	Drivetrain Trans and Axles
25072	HED 100	Contemp Health Problems	20899	AUTO 161	Automotive Electricity
29617	HED 101	Stress Management	30624	AUTO 181	Elec Engine Management Sys
29618	HED 101	Stress Management	29369	MATH 112	Elementary Statistics
29619	HED 101	Stress Management	29377	MATH 112	Elementary Statistics
30258	HED 101	Stress Management	29395	MATH 114	College Algebra
29296	HED 105	Mind, Body, and Health	29034	MATH 170	Analytic Geom & Calc I
29297	HED 202	Health Systems & Perspectives	20295	MATH 60	Elementary Algebra
22143	HIST 102	Political & Social Hist-U.S.	20316	MATH 80	Intermediate Algebra
28036	HUM 100	The Art of Being Human	22841	MATH 80	Intermediate Algebra
30586	HUM 100	The Art of Being Human	26473	MATH 80	Intermediate Algebra
24660	KIN 134	Theory of Football	29706	MATH 80	Intermediate Algebra
29364	MATH 80	Intermediate Algebra	20861	NRSRG 210	Fundamentals of Nursing
25533	MTT 56	CNC Shop Inspection	20862	NRSRG 210	Fundamentals of Nursing
23600	MTT 68	Computer-Assisted Inspection	20863	NRSRG 210	Fundamentals of Nursing
21406	NRSRG 251	Bas Adult Physical Assessment	20865	NRSRG 210	Fundamentals of Nursing
30562	NRSRG 251	Bas Adult Physical Assessment	27689	NRSRG 210	Fundamentals of Nursing
30560	NRSRG 80	Nursing Process Documentation	20869	NRSRG 220	Medical-Surgical Nursing 3
20786	PHYS 201	Engineering Physics	20870	NRSRG 220	Medical-Surgical Nursing 3
22443	PSYC 101	General Introductory Psyc	24202	NRSRG 220	Medical-Surgical Nursing 3
27931	PSYC 101	General Introductory Psyc	25520	NRSRG 220	Medical-Surgical Nursing 3
29103	PSYC 101	General Introductory Psyc	30059	NRSRG 220	Medical-Surgical Nursing 3
22418	PSYC 261	Social Psychology	20873	NRSRG 230	Psychosocial-Community Nsg
29273	PSYC 261	Social Psychology	20874	NRSRG 230	Psychosocial-Community Nsg
20549	SOC 101	Introduction Sociology-Principles	20875	NRSRG 230	Psychosocial-Community Nsg
20553	SOC 101	Introduction Sociology-Principles	20876	NRSRG 230	Psychosocial-Community Nsg
20554	SOC 101	Introduction Sociology-Principles	20877	NRSRG 230	Psychosocial-Community Nsg
20829	SOC 101	Introduction Sociology-Principles	20877	NRSRG 230	Psychosocial-Community Nsg
26427	SOC 101	Introduction Sociology-Principles	30391	NRSRG 230	Psychosocial-Community Nsg
20556	SOC 110	Marriage and the Family			
30640	SOC 120	Introduction to Human Sexuality			
21604	SOC 201	Social Problems			
27750	SOC 202	Gender and Society			
27416	TH 101	Introduction to the Theatre	27766	BA 108	Labor Management Relations
25135	TH 130	R & P For Minor Roles	29849	BA 109	Human Resource Development
25139	TH 131	R & P For Supporting Roles	29729	BA 110	Advertising
26502	TH 133	Stage Crew Activity	27422	BA 113	Legal Environment of Business

**2nd NINE WEEKS: 10/19/2020-12/18/2020**

Attendance is mandatory (including wait listed students). Failure to appear will jeopardize your official enrollment.

For a complete listing of all classes offered see pages #-#

## SHORT TERM CLASSES

Ticket#	Course#	Description	Ticket#	Course#	Description
29850	BA 113	Legal Environment of Business	26963	ENGL 234	Readings in Short Fiction
20650	BA 114	Marketing	28411	ENGT 116	Blueprint Reading
22124	BA 114	Marketing	25629	ESL 31	ESL Reading 2
26050	BA 114	Marketing	23435	FILM 241	Screenwriting
27761	BA 114	Marketing	23821	GEOG 102	Cultural Geography
22063	BA 115	Management-Business	29008	GEOG 103	Environmental Geology Lecture
23574	BA 115	Management-Business	30673	GEOG 208	The Age of the Dinosaurs
24421	BA 115	Management-Business	20901	HED 100	Contemp Health Problems
27448	BA 115	Management-Business	21314	HED 100	Contemp Health Problems
27762	BA 118	Retail Management	25028	HED 100	Contemp Health Problems
29095	BA 118	Retail Management	26741	HED 100	Contemp Health Problems
29096	BA 118	Retail Management	27579	HED 100	Contemp Health Problems
26218	BA 120	Management-Accountant & Internal Control	28926	HED 100	Contemp Health Problems
27763	BA 120	Management-Accountant & Internal Control	29620	HED 101	Stress Management
28285	BA 121	Sales	30574	HED 101	Stress Management
27764	BA 132	Computer Applications/Managers	30575	HED 101	Stress Management
27765	BA 132	Computer Applications/Managers	21839	HIST 103	Political & Social Hist-U.S.
29448	BA 132	Computer Applications/Managers	27457	HIST 103	Political & Social Hist-U.S.
29851	BA 132	Computer Applications/Managers	23421	HUM 100	The Art of Being Human
27285	BA 152	Fund Importing/Exporting	26743	KIN 100	Introduction to Kinesiology
27427	BA 153	Small Business Management	27995	KIN 100	Introduction to Kinesiology
26055	BA 155	Introduction Global Logistics	28511	KIN 100	Introduction to Kinesiology
26737	BA 156	Motivational Skills/Managers	28925	KIN 100	Introduction to Kinesiology
27145	BA 156	Motivational Skills/Managers	29826	KIN 100	Introduction to Kinesiology
29097	BA 156	Motivational Skills/Managers	29827	KIN 100	Introduction to Kinesiology
23585	BA 204	Project Management	27401	KIN 108	Women in Sports
29730	BA 205	Organizational Leadership	24661	KIN 134	Theory of Football
25738	BA 208	Leadership for Women in Bus	29631	KIN 211	Sport Management
26221	BA 208	Leadership for Women in Bus	28176	KIN 298	Directed Studies
21359	BCOT 113	Microsoft Excel	22163	LIBR 100	Introduction to Library Research
29684	BCOT 148	Effective Business Presentation	22170	LIBR 100	Introduction to Library Research
21350	BCOT 97	Microsoft Outlook	30610	MTT 110	IndustrialMaintenanceofMachine
25517	CA 55	Fund Of Responsible Alcohol Service	30666	MUS 208E	Pop/Rock Latin Ensemble
29800	CIS 101	Introduction Computer Info Systems	22196	NRSRG 215	Advanced Placement Bridge
26367	CIS 170H	TCP/IP Fundamentals	20919	NRSRG 232	Medical-Surgical Nursing 4
29361	CIS 58B	PC Core Hardware A+ Certification	20920	NRSRG 232	Medical-Surgical Nursing 4
24079	COMM 100	Introduction to Communication Studies	20921	NRSRG 232	Medical-Surgical Nursing 4
30189	COMM 100	Introduction to Communication Studies	20922	NRSRG 232	Medical-Surgical Nursing 4
25633	COMM 110	Intercultural Communication	20923	NRSRG 232	Medical-Surgical Nursing 4
28151	COMM 115	Gender, Comm,& Digital Revolution	27984	PHYS 203	Engineering Physics
29254	COMM 130	Public Speaking	27124	PMT 51	Composites Fabrication
24623	COMM 200	Contemporary Comm Topics	20795	POL 101	American Political Institution
30002	COS 55	Esthetics Crossover	21731	PSYC 101	General Introductory Psyc
22219	COS 60B	Introduction Cosmetology II	27932	PSYC 101	General Introductory Psyc
22223	COS 61B	Intermed Cosmetology II	27933	PSYC 101	General Introductory Psyc
22227	COS 62B	Advanced Cosmetology II	20519	PSYC 241	Introduction to Psychobiology
30004	COS 99	Directed Studies	24474	PSYC 261	Social Psychology
30306	COUN 200	Success College and Career	30029	PSYC 261	Social Psychology
30307	COUN 200	Success College and Career	27450	RE 101	Real Estate Principles
30540	DA 75	Clin II Coop Office Traing	20552	SOC 101	Introduction Sociology-Principles
22083	DANC 100	Dance Appreciation	20555	SOC 101	Introduction Sociology-Principles
26742	DANC 100	Dance Appreciation	21607	SOC 101	Introduction Sociology-Principles
28682	DANC 100	Dance Appreciation	24479	SOC 101	Introduction Sociology-Principles
28924	DANC 100	Dance Appreciation	24480	SOC 101	Introduction Sociology-Principles
29824	DANC 100	Dance Appreciation	27749	SOC 101	Introduction Sociology-Principles
21249	EDT 125	Fund of Online Teaching	27983	SOC 110	Marriage and the Family
30023	EDT 132	Using Audio in the Classroom	20561	SOC 120	Introduction to Human Sexuality
30025	EDT 139	E-Portfolios for Education	26208	SOC 201	Social Problems
30026	EDT 141	Web Design for Educators	30639	SOC 202	Gender and Society
30022	EDT 77	Using Mind-Mapping Tools in Ed	24481	SOC 210	American Minority Relations
25091	ENGL 100	Freshman Composition	20839	TH 101	Introduction to the Theatre
25191	ENGL 100	Freshman Composition	27417	TH 101	Introduction to the Theatre
30138	ENGL 100	Freshman Composition	25137	TH 130	R & P For Minor Roles
30158	ENGL 100	Freshman Composition	25141	TH 131	R & P For Supporting Roles
30160	ENGL 100	Freshman Composition	25133	TH 132	R & P For Lead Roles
30394	ENGL 100	Freshman Composition	23434	TH 150	App & Hist Motion Picture
30398	ENGL 100	Freshman Composition	27974	TH 150	App & Hist Motion Picture
30082	ENGL 100S	Enhanced Freshman Composition	29752	TH 150	App & Hist Motion Picture
30097	ENGL 100S	Enhanced Freshman Composition	27400	WGS 108	Women in Sports
30099	ENGL 100S	Enhanced Freshman Composition	28198	WGS 115	Gender,Comm,&the Digital Revolution
30123	ENGL 100S	Enhanced Freshman Composition	30638	WGS 202	Gender and Society
21476	ENGL 103	Critical/Argumentative Wrt	29113	WGS 207	Women and Media
30165	ENGL 110	Critical Thinking Through Literature	26385	WGS 208	Leadership for Women in Bus
			26386	WGS 208	Leadership for Women in Bus
			26973	ESL 152	Introduction Col Comp Non-Native

Attendance is mandatory (including wait listed students). Failure to appear will jeopardize your official enrollment.

For a complete listing of all classes offered see pages #-#

## SHORT TERM CLASSES

Ticket#	Course#	Description	Ticket#	Course#	Description
20900	CA 101	English Introduction/Food Service Safety-Sanitization	28177	KIN 298	Directed Studies
29069	COUN 10	Career Planning	30342	MATH 60	Elementary Algebra
21959	FIN 51	Retirement Plan/Investing	30341	MATH 80	Intermediate Algebra
21173	PHAR 63	Pharmacy Operations II	20550	SOC 101	Introduction Sociology-Principles
30565	PHAR 63	Pharmacy Operations II	21787	SOC 101	Introduction Sociology-Principles
30566	PHAR 63	Pharmacy Operations II	27443	SOC 101	Introduction Sociology-Principles
29074	NRSG 25	Clinical Workshop 1	20830	SOC 110	Marriage and the Family
30558	NRSG 25	Clinical Workshop 1	29128	SOC 202	Gender and Society
21192	NRSG 26	Clinical Workshop 2	29111	WGS 118	History of Women in Visual Art
30559	NRSG 26	Clinical Workshop 2	29112	WGS 202	Gender and Society
20952	PHAR 50	Pharmaceutics	25671	ECON 202	Principles of Microeconomics
30056	HO 56	Medication Calculations	25673	ECON 202M	Principles of Microeconomics
22624	ECON 202	Principles of Microeconomics	26791	ECON 101	Econ Issues and Policy
22634	ECON 202M	Principles of Microeconomics	30334	MATH 140	Trigonometry
27270	HIST 102	Political & Social Hist-U.S.	30582	ART 193	Motion Picture Editing
26480	PEX 124	Personal Fitness Program	30584	ART 194A	Advanced Final Cut Pro
25944	PEX 184	Swimming, Novice	24440	ECON 201M	Principles of Macroeconomics
25946	PEX 185	Swimming, Beginning	<b>2nd FIFTEEN WEEKS: 09/08/2020-12/18/2020</b>		
30140	ENGL 100	Freshman Composition	21938	ACCT 133	Spreadsheet Accounting I
29220	ESL 35	Edit Adv Grammar/Syntax	28138	ACCT 220	Accounting Ethics
27429	HED 103	Women, Their Bodies/Health	29090	ACCT 250	Income Tax Accounting
29302	PEX 100	Fitness for Student's with Dis	27768	ACCT 270	Fundamentals Of Auditing
24726	PEX 104	Adapted Stretching & Relaxatio	30446	AED 22.06	Career Skills
30289	PEX 136	Stretching and Relaxation	30447	AED 22.06	Career Skills
27466	POL 101	American Political Institution	29562	AED 36.06	Occupational Training
27430	WGS 103	Women, their Bodies and Health	30438	AED 42.12	GED Preparation-A
21292	AUTO 161	Automotive Electricity	29464	AED 42.20	LiteracySkills for GED Success
27603	AUTO 181	Elec Engine Management Sys	29473	AED 42.20	LiteracySkills for GED Success
29389	MATH 112	Elementary Statistics	29474	AED 42.20	LiteracySkills for GED Success
29391	MATH 112	Elementary Statistics	29475	AED 42.20	LiteracySkills for GED Success
29439	MATH 114	College Algebra	28077	AED 42.21	SpanishLiteracySkills for GED
29365	MATH 140	Trigonometry	29456	AED 42.21	SpanishLiteracySkills for GED
29405	MATH 140	Trigonometry	29457	AED 42.21	SpanishLiteracySkills for GED
29705	MATH 190	Analytic Geom & Calc II	29458	AED 42.21	SpanishLiteracySkills for GED
22326	MATH 80	Intermediate Algebra	28079	AED 42.22	Supplemental GED Math
29708	MATH 80	Intermediate Algebra	28223	AED 42.22	Supplemental GED Math
20912	NRSG 212	Medical-Surgical Nursing I	28119	AED 42.23	Spanish Supplemental GED Math
20913	NRSG 212	Medical-Surgical Nursing I	29459	AED 42.23	Spanish Supplemental GED Math
20914	NRSG 212	Medical-Surgical Nursing I	28104	AED 49.01	Preparatory Math
20915	NRSG 212	Medical-Surgical Nursing I	21365	ANTH 100	Cultural Anthropology
21639	NRSG 212	Medical-Surgical Nursing I	21332	ANTH 115	Physical Anthropology
20917	NRSG 222	Maternal/Child Nursing	26734	ANTH 115	Physical Anthropology
21641	NRSG 222	Maternal/Child Nursing	30372	ANTH 115	Physical Anthropology
22146	NRSG 222	Maternal/Child Nursing	30605	AUTO 100	Auto Maint And Operation
22358	NRSG 222	Maternal/Child Nursing	21772	BA 100	Fundamentals of Business
24203	NRSG 222	Maternal/Child Nursing	28277	BA 109	Human Resource Development
<b>2nd TWELVE WEEKS: 09/28/2020-12/18/2020</b>			25589	BA 113	Legal Environment of Business
23433	TH 101	Introduction to the Theatre	26212	BA 113	Legal Environment of Business
30066	SLP 246	Clinical Experience II	21441	BA 115	Management-Business
29243	COMM 100	Introduction to Communication Studies	23987	CIS 101	Introduction Computer Info Sysrms
<b>1st FIFTEEN WEEKS: 08/17/2020-11/27/2020</b>			25183	CIS 103	Computer Programming Logic
22534	ART 101	Art History I	28997	CIS 151	Microsoft Excel for IS/IT
26174	ART 102	Art History II	26885	CIS 155	Microsoft Access
29720	ART 118	History of Women in Visual Art	24311	CIS 170B	Network + Certification
26054	BA 100	Fundamentals of Business	29001	CIS 170I	Cisco Network Security
29094	BA 106	Human Resource Management	29712	CIS 180	Programming in C/C++
25588	BA 107	Human Relations In Bus	28282	CIS 212	Introduction to Windows Admin
21773	BA 113	Legal Environment of Business	28737	CIS 213F	Ms Windows Server Admin
22551	BA 120	Management-Accountant & Internal Control	27468	COMM 100	Introduction to Communication Studies
30019	BA 126	E-learning	29244	COMM 100	Introduction to Communication Studies
25592	BA 156	Motivational Skills/Managers	30190	COMM 100	Introduction to Communication Studies
27607	COS 54A	Advanced Esthetician	30191	COMM 100	Introduction to Communication Studies
20193	ENGL 100	Freshman Composition	24624	COMM 103	Argumentation,Persuasion,Crit,
26399	ENGL 100	Freshman Composition	26988	COMM 103	Argumentation,Persuasion,Crit,
27034	JOUR 100	Mass Commn and Society	30192	COMM 115	Gender,Comm,&DigitalRevolution
			24619	COMM 130	Public Speaking
			24622	COMM 140	Oral Interpretation Of Literature
			30195	COMM 145	Storytelling
			24231	COS 54	Introductory Esthetician
			29585	COUN 200	Success College and Career
			27084	DANC 100	Dance Appreciation

Attendance is mandatory (including wait listed students). Failure to appear will jeopardize your official enrollment.

For a complete listing of all classes offered see pages #-#



## SHORT TERM CLASSES

Ticket#	Course#	Description	Ticket#	Course#	Description
30220	DANC 101	History of Dance	29088	TH 212	Scene Study
29118	ECON 102	Women in the Global Economy	30390	WGS 140	Introduction to LGBT Studies
21425	EDEL 100	Introduction To Teaching	29640	WGS 206	Women in the Global Economy
29123	EDEL 100	Introduction To Teaching	28003	PSYC 150	Pers & Soc Adjustment
29754	EDEL 100	Introduction To Teaching	26110	RE 52	Mortg Loan Brokering/Lending
29441	EDT 110	Introduction To Ed Technology	28514	TH 151	Motion Pictures/Radio & TV
23466	ENGL 100	Freshman Composition	25664	BA 113	Legal Environment of Business
27316	ENGL 100	Freshman Composition	25989	ECON 101	Econ Issues and Policy
28236	ENGL 100	Freshman Composition	30035	ECON 202	Principles of Microeconomics
29746	ENGL 100	Freshman Composition	30037	ECON 202M	Principles of Microeconomics
30159	ENGL 100	Freshman Composition	20472	PHIL 100	Introduction to Philosophy
30392	ENGL 100	Freshman Composition	21986	LAW 111	Business Law
30397	ENGL 100	Freshman Composition	27746	PHIL 100	Introduction to Philosophy
30679	ENGL 100	Freshman Composition	25515	ECON 101	Econ Issues and Policy
30694	ENGL 100	Freshman Composition	21316	HED 100	Contemp Health Problems
30070	ENGL 100S	Enhanced Freshman Composition	29584	COUN 200	Success College and Career
30072	ENGL 100S	Enhanced Freshman Composition	23471	ENGL 230A	Introduction to American Literature
30086	ENGL 100S	Enhanced Freshman Composition	26970	ESL 10	ESL Speaking & Listening 1
30093	ENGL 100S	Enhanced Freshman Composition	22678	ESL 3	ESL Grammar, Read, & Writing 3
30121	ENGL 100S	Enhanced Freshman Composition	26023	ESL 4	ESL Grammar, Reading & Writing 4
30125	ENGL 100S	Enhanced Freshman Composition	30381	HIST 102	Political & Social Hist-U.S.
30161	ENGL 100S	Enhanced Freshman Composition	30261	KIN 100	Introduction to Kinesiology
30163	ENGL 100S	Enhanced Freshman Composition	22300	MATH 114	College Algebra
30680	ENGL 100S	Enhanced Freshman Composition	28409	MATH 140	Trigonometry
30684	ENGL 100S	Enhanced Freshman Composition	28503	MATH 60	Elementary Algebra
29647	ENGL 102	Introduction to Literature	30273	PEX 122	Cross Fit Training and Func Ex
24546	ENGL 103	Critical/Argumentative Wrt	30287	PEX 135	Ropes, Bands, and Suspension
26408	ENGL 103	Critical/Argumentative Wrt	23789	POL 101	American Political Institution
27773	ENGL 225	Mexican Literature. in Translation	23790	POL 101	American Political Institution
20221	ENGL 246A	Survey of Brit Literature A:Anglo-Sax	25200	ACCT 100	Introduction to Accounting
24237	ENGT 103	Introduction to Eng Design Using Inv	20581	COMM 110	Intercultural Communication
30650	ESL 10	ESL Speaking & Listening 1	29796	ENGL 100	Freshman Composition
23699	ESL 120	Prep For Col Writing-NonEngl	25481	ENGL 228	Shakespeare's Plays
23479	ESL 14	Pronunciation Plus	25488	ESL 152	IntroCol Comp Non-Native Engl
27913	ESL 152	IntroCol Comp Non-Native Engl	26764	HIST 102	Political & Social Hist-U.S.
30651	ESL 20	ESL Speaking & Listening 2	30260	KIN 100	Introduction to Kinesiology
30171	ESL 21A	ESL Intermed Vocabulary	29388	MATH 112	Elementary Statistics
29623	ESL 5	ESL Grammar, Reading, & Writing 5	29367	MATH 114	College Algebra
30013	FIN 125M	Personal Finance	23812	MATH 60	Elementary Algebra
30371	FIN 125M	Personal Finance	26256	PEX 124	Personal Fitness Program
27055	GEOG 101	Physical Geography	25064	PEX 130	Weight Management
24461	HIST 103	Political & Social Hist-U.S.	30292	PEX 142	Group Tmill; Cardio Mach Train
24462	HIST 103	Political & Social Hist-U.S.	29451	PHIL 160	Symbolic Logic
26761	HIST 103	Political & Social Hist-U.S.	25991	POL 101	American Political Institution
30382	HIST 103	Political & Social Hist-U.S.	29715	PSYC 101	General Introductory Psyc
27272	HIST 110	African/American History	25994	PSYC 245	Drugs and Behavior
29124	HIST 260	Survey of the History of Asia	27754	WGS 105	GenderStudies&Chicana/LatinaEx
27711	KIN 211	Sport Management	24835	PEX 151	Yoga
27982	LAW 110	Business Law	30430	PEX 152	Gentle Yoga
28736	MATH 112	Elementary Statistics			
29723	MATH 112	Elementary Statistics			
29724	MATH 112	Elementary Statistics			
29737	MATH 140	Trigonometry			
29716	MATH 80	Intermediate Algebra			
29736	MATH 80	Intermediate Algebra			
30269	PEX 121	High-Intensity Interval Train			
23785	PHIL 100	Introduction to Philosophy			
30011	PMT 76	Vacuum Infusion/RTM			
20935	POL 101	American Political Institution			
21275	POL 101	American Political Institution			
23994	POL 101	American Political Institution			
26738	PSYC 103	Critical Thinking In Psych			
21971	RE 101	Real Estate Principles			
21972	RE 130	Real Estate Practice			
29629	READ 101	Read & Learn Strategies College Stu			
30184	READ 101	Read & Learn Strategies College Stu			
30186	READ 101	Read & Learn Strategies College Stu			
30187	READ 101	Read & Learn Strategies College Stu			
28515	RTV 151	Motion Pictures/Radio & TV			
26209	SOC 205	Introduction to Soc Research Methods			
26098	TH 101	Introduction to the Theatre			
27696	TH 110	Fundamentals of Acting			
30596	TH 112	Script Analysis			
20958	TH 150	App & Hist Motion Picture			
21291	TH 150	App & Hist Motion Picture			
			30442	AED 42.03	Survival ESL
			30443	AED 42.03	Survival ESL
			30440	AED 42.10	Spanish Ged Test Prep-A
			30441	AED 42.10	Spanish Ged Test Prep-A
			29470	AED 42.11	Spanish Ged Test Prep-B
			29471	AED 42.11	Spanish Ged Test Prep-B
			30436	AED 42.12	GED Preparation-A
			30437	AED 42.12	GED Preparation-A
			29461	AED 42.13	Ged Preparation-B
			27198	AED 42.16	Low Intermediate ESL
			27300	AED 42.18	Low Adv Engl as a Second Lang
			30448	AED 48.05	College English Skills
			30450	AED 48.05	College English Skills
			28094	AED 49.01	Preparatory Math
			28100	AED 49.01	Preparatory Math
			29648	AED 49.02	Vocational ESL
			28076	AED 60.01	Citizenship I
			28137	AED 60.01	Citizenship I
			30445	AED 60.01	Citizenship I
			29634	AED 90.04	Introduction to Auto Tools & Equipment
			22361	DANC 106A	Beginning Ballet
			26235	DANC 106B	Intermediate Ballet

### SIXTEEN WEEKS: 08/21/2020-12/13/2020

Attendance is mandatory (including wait listed students). Failure to appear will jeopardize your official enrollment.

For a complete listing of all classes offered see pages #-#

## SHORT TERM CLASSES

Ticket#	Course#	Description	Ticket#	Course#	Description
30231	DANC 106C	Advanced Ballet			
26237	DANC 107	Ballet Variations			
26413	ENGL 103	Critical/Argumentative Wrt			
30534	ENGL 103	Critical/Argumentative Wrt			
30048	FILM 104	Motion Picture & Digital Cinem			
25744	MTT 100	Machine Tool Introduction			
27063	PHYS 201	Engineering Physics			
27923	SPAN 101	Elementary Spanish			
24593	SPAN 223	Spanish for Health/Medical			
30353	WMT 151	Introduction Faceframe Cabinet			
29368	MATH 112	Elementary Statistics			
29401	MATH 114	College Algebra			

### SEVENTEEN WEEKS: 08/17/2020-12/18/2020

28164	DANC 134	Dance Performance
27290	DANC 136	Dance Repertory
27702	DANC 50	Indv Dance Development
29714	MATH 80	Alintermediate Algebra I
29725	MATH 80A	Intermediate Algebra I
29726	MATH 60	Elementary Algebra

Attendance is mandatory (including wait listed students). Failure to appear will jeopardize your official enrollment.

For a complete listing of all classes offered see pages #-#



## NO FEE NON-CREDIT CLASSES

The following information will help you register for non-credit classes offered by Cerritos College. In non-credit classes students build the basic skills needed for personal and professional growth. Students in non-credit classes do not earn units toward the award of a credit degree or certificate, and are not required to pay registration fees for these courses. Instruction in English as a Second Language, General Education Development, Assessment Preparation, Citizenship and other basic skills are offered within the non-credit Adult Education unit. Some classes are offered in both English and Spanish. Most non-credit classes take place off-campus at community sites. Classes for students with disabilities require a separate registration process.

More information is available by calling the offices of:  
 Adult Education .....(562) 467-5098  
 Emeritus - Older Wiser Learner .....(562) 467-5098

## REGISTRATION

### STEPS TO ENROLL IN NON-CREDIT CLASSES

1. IDENTIFY THE CLASS OR CLASSES YOU WISH TO TAKE  
Review the course list and identify class and ticket number.
2. COMPLETE REGISTRATION FORM  
Complete a Cerritos College application online at [www.cerritos.edu](http://www.cerritos.edu); select "Apply Online".
3. WALK-IN REGISTRATION  
You may register online or in person at the Office of Adult Education & Diversity Programs. Call (562) 467-5098 for office hours.  
If you are registering for an ESL, or Vocational ESL, or GED class, an assessment test will need to be taken.
4. SCHEDULE AN APPOINTMENT WITH COUNSELOR  
Counselors are available to talk with you about the right courses for you. Call (562) 467-5098 to schedule an appointment.

# ADULT EDUCATION AND DIVERSITY PROGRAMS

## CLASES GRATIS DE NO-CREDITO DEL COLEGIO

Lo siguiente le ayudará a matricularse para clases de no-crédito del Colegio de Cerritos. En las clases de no-crédito, los estudiantes mejoran sus habilidades académicas básicas necesarias para el desarrollo personal y profesional. Las clases de no-crédito no se aplican para título o certificado en los programas de crédito. Se ofrecen clases de Inglés como Segundo Idioma, Diploma de Preparatoria, Preparación de Evaluación, Ciudadanía, y otras clases de habilidades académicas. La mayoría de las clases de no-crédito se ofrecen en sitios distintos de la comunidad. Clases para estudiantes con discapacidades requieren de una matriculación aparte.

Para información en español, llame a las oficinas de:  
 Educación de Adultos .....(562) 467-5098  
 Programa de educación para adultos de mayor edad .....(562) 467-5098

## REGISTRACIÓN

### COMO MATRICULARSE EN CLASES DE NO-CRÉDITO

1. Escoja la clases o clase que le gustaria tomar.
2. Llene la aplicacion de registración para Cerritos College por internet [www.cerritos.edu](http://www.cerritos.edu), presione Apply Online, opción en Español.
3. Registracion en persona.  
Al llenar la aplicacion de registración, venga a la oficina de Educacion para Adultos localizada en el edificio de CE II.  
Registración para los cursos de Inglés Como Segundo Idioma requieren una prueba de evaluación. Llame la oficina para mas información (562) 467-5098.
4. Consulte con un consejero.  
Consejeros que hablan español están disponibles. Para hacer una cita, llame al (562) 467-5098.

Class#	Time	Day	Instructor	Room	Class#	Time	Day	Instructor	Room
--------	------	-----	------------	------	--------	------	-----	------------	------

## CITIZENSHIP

This course prepares adults for the citizenship process, the INS examination, and interview. The course will also emphasize oral communication and strengthen English language skills for those limited in English.

Prepárese para el examen de ciudadanía y la entrevista con inmigración, aprendiendo al mismo tiempo Inglés.

### AED 60.01 - 0.0 UNIT CITIZENSHIP I

Not Transferable

28245	8:30-12:20PM	T	Martinez,D	MESP*
<b>28075</b>	<b>6:00- 7:50PM</b>	<b>TTh</b>	Maris-Gramajo,E	IGL*
29675	9:00-12:50PM	F	Maris-Gramajo,E	SNPK*
28076	8:00-12:15PM	Sat	Nunez,M	CB101
Class# 28076 meets 08/22/2020-12/12/2020				
28137	8:00-12:15PM	Sat	Lozano,J	CCHA*
Class# 28137 meets 08/22/2020-12/12/2020				
30445	8:00-12:15PM	Sat	Cardona,R	CCHA*
Class# 30445 meets 08/22/2020-12/12/2020				

## ENGLISH AS A SECOND LANGUAGE

Five levels are offered to assist you in your language development. Emphasis is placed on oral communication and conversational language.

Cinco niveles de Inglés se ofrecen para ayudarle a desarrollar sus conocimientos del idioma Inglés. Esta clase esta enfocada en comunicacion oral y conversacion del idioma Inglés.

### AED 42.14 - 0.0 UNIT LOW BEGINNING ENGLISH AS A SECOND LANGUAGE

Not Transferable

<b>22915</b>	<b>6:00- 8:50PM</b>	<b>TTh</b>	Kouznetsova,O	CE 2
--------------	---------------------	------------	---------------	------

### AED 42.15 - 0.0 UNIT HIGH BEGINNING ENGLISH AS A SECOND LANGUAGE

Not Transferable

<b>28200</b>	<b>6:00- 8:50PM</b>	<b>MW</b>	Fragoso,M	CE 6
--------------	---------------------	-----------	-----------	------

### AED 42.16 - 0.0 UNIT LOW INTERMEDIATE ENGLISH AS A SECOND LANGUAGE

Not Transferable

28044	8:30-11:20AM	MW	Mondaca,F	SL109
27198	8:30- 2:55PM	Sat	Tucker,J	SL108
Class# 27198 meets 08/22/2020-12/12/2020				

### AED 42.17 - 0.0 UNIT HIGH INTERMEDIATE ENGLISH AS A SECOND LANGUAGE

Not Transferable

<b>28046</b>	<b>6:00- 8:50PM</b>	<b>MW</b>	STAFF	SL108
28068	8:30-11:20AM	TTh	Amanat-Lee,J	SL108
29686	8:30- 2:55PM	Sat	Sanchez,S	SL107

### AED 42.18 - 0.0 UNIT LOW ADVANCED ENGLISH AS A SECOND LANGUAGE

Not Transferable

Prerequisite: Pass AED 42.17 High Intermediate English as a Second Language course or assess into AED 42.18.

27298	8:30-11:20AM	MW	Sanchez,S	SL108
<b>28121</b>	<b>6:30- 9:20PM</b>	<b>MW</b>	Nunez,M	SL107
27300	8:30- 2:55PM	Sat	Mobley,T	SL109
Class# 27300 meets 08/22/2020-12/12/2020				

## SURVIVAL ESL

This first course in a series is designed as a survival-level English language course for those students with no English language skills. All language learning skills will be utilized: reading, writing, listening, and speaking; the main focus will be on vocabulary building and listening as initial steps for building English language acquisition.

Este curso de Inglés básico de sobrevivencia esta diseñado para aquellos estudiantes con pocas habilidades en este idioma. Todas las enseñanzas del language aprendido podrán ser utilizadas: Leyendo, escribiendo, escuchando y hablando. El tema central es el vocabulario. Construyendo vocabulario y escuchando es el paso inicial para adquirir el lenguaje Inglés.

### AED 42.03 - 0.0 UNIT SURVIVAL ESL

Not Transferable

28267	8:30-11:20AM	MW	Amanat-Lee,J	SL107
28059	9:00-11:50AM	MW	Lozano,J	MESP*
29735	8:30-11:20AM	TTh	Mobley,T	CE 1
29780	8:30-11:20AM	TTh	Mobley,T	WD 1
B29462	6:00- 8:50PM	TTh	Perez Juarez,M	CE 1
B30675	6:00- 8:50PM	TTh	Fragoso,M	SNPK*
30442	9:00-11:50AM	F	Zugschwerdt,S	DAS *
Class# 30442 meets 08/21/2020-12/11/2020				
30443	8:30- 2:55PM	Sat	Robles,M	CE 7
Class# 30443 meets 08/22/2020-12/12/2020				

## VOCATIONAL ENGLISH AS A SECOND LANGUAGE

This course is designed as a survey of work-related communication including nomenclature for the student with limited English language skills. Students will learn to recognize, produce, and understand technical vocabulary utilizing language learning skills: speaking, listening, reading and writing. Students will learn about vocation and nomenclature, while increasing their English language acquisition by learning to ask and respond to questions related to the vocation and practice conversation on a variety of work-related subjects. Students will expand their vocational knowledge via class discussions, reading print material, attending field trips, and by sharing their vocational experiences with other students. This course is intended as preparation for future credit courses, vocational training, or increased vocational language acquisition for the work situation.

Este curso esta diseñado para la comunicación en los trabajos, incluye nomenclatura para el estudiante limitado en el idioma Inglés. Los estudiantes aprenderán a reconocer, pronunciar y entender el vocabulario técnico por medio de escuchar, hablar, escribir y leer. Este curso tiene el objetivo de prepararlo para futuras clases de credito, entrenamientos vocacionales o incrementar la adquisición del lenguaje necesario para una situación en el trabajo.

### AED 49.02 - 0.0 UNIT VOCATIONAL ENGLISH AS A SECOND LANGUAGE

Not Transferable

27249	9:00-11:05AM	MW	Robles,M	ABBS*
28071	2:30- 4:35PM	TTh	Ramos,M	NOR *
<b>30674</b>	<b>5:30- 7:35PM</b>	<b>TTh</b>	Ramos,M	SNPK *
29648	8:30- 1:20PM	F	Perez Juarez,M	MESP*
Class# 29648 meets 08/21/2020-12/11/2020				

If a class displays as **REMOTE** in the schedule, students will be expected to log into the class at a specified day/time (e.g., MW 8-9:15am). If the class displays as **ONLINE** in the schedule, students are permitted to log into the class whenever they are available to complete coursework by the established deadlines.

Students not in attendance or late for the first class meeting are subject to drop.

Class#	Time	Day	Instructor	Room	Class#	Time	Day	Instructor	Room
--------	------	-----	------------	------	--------	------	-----	------------	------

## COLLEGE ENGLISH SKILLS

This beginning course is designed for students already able to understand and speak the English language. This course is not recommended for students working on secondary language skills who would be better served by an ESL course. It is intended to reduce beginning writing students' fear and anxiety about writing. It develops writing fluency through written activities and assignments designed to teach and reinforce conventions of Standard English. This course focuses on sentence structure and development and sentence combining. Students will work toward developing short paragraphs.

Este curso está diseñado para desarrollar la escritura combinando actividades y tareas diseñadas para reforzar las habilidades de escritura en el idioma inglés.

### AED 48.05 - 0.0 UNIT COLLEGE ENGLISH SKILLS

Not Transferable

28048	9:00-10:00AM	MW	Morrison,A	MP105
	10:00-10:50AM	MW	Morrison,A	MP105
28050	9:00-10:00AM	TTh	STAFF	MP105
	10:00-10:50AM	TTh	STAFF	MP105
30448	9:00-11:15AM	F	Robles,M	MP105
	Class# 30448 meets 08/21/2020-12/11/2020			
30449	11:15- 1:15PM	F	Robles,M	MP105
	Class# 30449 meets 08/21/2020-12/11/2020			
30450	9:00-11:10AM	Sat	Amanat-Lee,J	MP104
	Class# 30450 meets 08/22/2020-12/12/2020			
30451	11:10- 1:15PM	Sat	Amanat-Lee,J	MP104
	Class# 30451 meets 08/22/2020-12/12/2020			

## PREPARATORY MATHEMATICS

This course is for students who wish to master basic mathematical skills in order to pursue subsequent mathematical courses, gain personal enrichment, and develop career readiness. It covers the concepts of addition, subtraction, multiplication and division of whole numbers, fractions, mixed numbers, decimals, and percentages, with an emphasis on real-world applications.

Este curso es para estudiantes que deseen dominar las bases en matemáticas para que pueden alcanzar sus siguientes cursos de matemáticas, desarrollo interpersonal y enriquecimiento de sus habilidades. La clase cubre conceptos de adición, sustracción, multiplicación, fracciones y números mixtos, decimales y porcentajes, con un énfasis en problemas de palabras.

### AED 49.01 - 0.0 UNIT PREPARATORY MATH

Not Transferable

28086	9:00-10:00AM	MW	Barrera De Contreras	MP103
	10:00-10:50AM	MW	Barrera De Contreras	MP103
<b>28104</b>	<b>6:00- 7:10PM</b>	<b>TTh</b>	Bonakdar,M	MP103
	Class# 28104 meets 09/08/2020-12/17/2020			
<b>28105</b>	<b>7:10- 8:10PM</b>	<b>TTh</b>	Bonakdar,M	MP103
	Class# 28105 meets 09/08/2020-12/17/2020			
28094	8:30-10:45AM	F	Barrera De Contreras	MP103
	Class# 28094 meets 08/21/2020-12/11/2020			
28095	10:45-12:45PM	F	Barrera De Contreras	MP103
	Class# 28095 meets 08/21/2020-12/11/2020			
28100	8:00-10:10AM	Sat	Samel,C	MP103
	Class# 28100 meets 08/22/2020-12/12/2020			
28101	10:10-12:15PM	Sat	Samel,C	MP103
	Class# 28101 meets 08/22/2020-12/12/2020			
28106	9:00-11:50AM	TTh	Barrera De Contreras	MP104
	Class# 28106 meets 10/20/2020-12/17/2020			
28107	11:50-12:50PM	TTh	Barrera De Contreras	MP104
	Class# 28107 meets 10/20/2020-12/17/2020			

## COLLEGE PLACEMENT STRATEGIES A

This course will build pre-college level proficiency to prepare students for the community college assessment test in reading comprehension and sentence skills. Students will develop fundamental concepts of reading and writing and gain familiarity with the basic testing format. The combination lecture/lab format will expose students to various mediums of instruction and strengthen their knowledge of testing strategies.

This course is presented in a modular format.

Este curso desarrollará la competencia a nivel preuniversitario para preparar a los estudiantes para el examen de evaluación de la universidad comunitaria en comprensión de lectura y habilidades de oración. Los estudiantes desarrollarán conceptos fundamentales de lectura y escritura y se familiarizarán con el formato de prueba básico. El formato combinado de lectura / laboratorio expondrá a los estudiantes a varios medios de instrucción y fortalecerá su conocimiento de las estrategias de evaluación. Este curso se presenta en formato modular.

### AED 42.98 - 0.0 UNIT COLLEGE PLACEMENT TESTING STRATEGIES

Not Transferable

29479	11:00-12:00PM	MW	Morrison,A	MP105
	Class# 29479 meets 08/17/2020-12/18/2020			
29480	12:00-12:50PM	MW	Morrison,A	MP105
	Class# 29480 meets 08/17/2020-12/18/2020			

## OLDER WISER LEARNER (FORMERLY EMERITUS COLLEGE)

The Older Wiser Learner program offers special interest, noncredit classes for adults.

These courses are designed to support lifelong learning. Register in the class.

Classes are open enrollment.

El programa de aprendizaje para personas de la tercera edad ofrece clases de interés especial, sin crédito para adultos. Estos cursos están diseñados para apoyar el aprendizaje de por vida. Regístrese ahora las inscripciones están abiertas.

### AED 11.08 - 0.0 UNIT STRESS MANAGEMENT/OLDER ADULT

Not Transferable

22931	1:00- 2:00PM	M	Layne,J	NSC*
	2:00- 2:50PM	M	Layne,J	NSC*
22933	3:00- 4:00PM	M	Layne,J	NSC*
	4:00- 4:50PM	M	Layne,J	NSC*
22935	1:00- 2:30PM	T	Lozano,J	DCC*
	2:30- 3:50PM	T	Lozano,J	DCC*
22937	1:00- 2:30PM	F	Lozano,J	DCC*
	2:30- 3:50PM	F	Lozano,J	DCC*
22939	10:00-10:30AM	MW	Van Herk,T	LMGM*
	10:30-10:50AM	MW	Van Herk,T	LMGM*
22941	1:00- 2:00PM	M	Van Herk,T	CSRC*
	2:00- 2:50PM	M	Van Herk,T	CSRC*
22943	1:00- 2:00PM	W	Van Herk,T	LMGM*
	2:00- 2:50PM	W	Van Herk,T	LMGM*
22945	9:45-10:15AM	TTh	Van Herk,T	GROV*
	10:15-10:35AM	TTh	Van Herk,T	GROV*
22947	8:15- 8:45AM	MW	Van Herk,T	NBRC*
	8:45- 9:05AM	MW	Van Herk,T	NBRC*
22949	9:00-10:00AM	F	Van Herk,T	ACH*
	10:00-10:50AM	F	Van Herk,T	ACH*
22952	11:15-11:45AM	MW	Van Herk,T	LMGM*
	11:45-12:05PM	MW	Van Herk,T	LMGM*
22954	7:30- 8:00AM	MW	Jackson,M	CSRC*
	8:00- 8:20AM	MW	Jackson,M	CSRC*
27211	9:15- 9:45AM	MW	Jackson,M	NSC*
	9:45-10:05AM	MW	Jackson,M	NSC*
27213	10:15-10:45AM	MW	Jackson,M	NSC*
	10:45-11:05AM	MW	Jackson,M	NSC*
<b>27215</b>	<b>5:00- 5:30PM</b>	<b>MW</b>	Jackson,M	CSRC*
	5:30- 5:50PM	MW	Jackson,M	CSRC*
27217	1:00- 2:00PM	F	Jackson,M	LMAC*
	2:00- 2:50PM	F	Jackson,M	LMAC*
27219	11:00-11:30AM	F	Van Herk,T	ACH*
	2:00- 2:30PM	T	Van Herk,T	ACH*

If a class displays as **REMOTE** in the schedule, students will be expected to log into the class at a specified day/time (e.g., MW 8-9:15am). If the class displays as **ONLINE** in the schedule, students are permitted to log into the class whenever they are available to complete coursework by the established deadlines.

Students not in attendance or late for the first class meeting are subject to drop.

Class#	Time	Day	Instructor	Room	Class#	Time	Day	Instructor	Room
27220	11:30-11:50AM	F	Van Herk,T	ACH*					
	2:30- 2:50PM	T	Van Herk,T	ACH*					
27221	1:00- 1:30PM	MW	Jackson,M	LMAC*					
	1:30- 1:50PM	MW	Jackson,M	LMAC*					
27223	1:00- 1:30PM	TTh	Jackson,M	LMAC*					
	1:30- 1:50PM	TTh	Jackson,M	LMAC*					

### AED 22.09 - 0.0 UNIT TOPICS OF INTEREST SENIORS

Not Transferable

22900	9:00-10:50AM	F	Levy,E	NSC*
22901	12:00- 1:50PM	M	Levy,E	WDCR*
22902	12:00- 1:50PM	F	Levy,E	LMAC*
22903	10:00-11:50AM	W	Levy,E	FOUN*
22907	1:00- 2:50PM	T	Levy,E	FOUN*
22957	1:00- 2:50PM	Th	Levy,E	FOUN*
27230	3:00- 4:50PM	M	Levy,E	CSRC*
27231	3:00- 4:50PM	Th	Levy,E	NSC*

### AED 48.03 - 0.0 UNIT CREATIVE WRITING FOR SENIORS

Not Transferable

22908	2:00- 3:50PM	Th	Mansell,B	NSC*
27233	2:00- 3:50PM	T	Mansell,B	NSC*

## CAREER SKILLS

The Career Skills course is tailored to help students build or improve their interpersonal skills in the workplace. The course will allow students to develop a broad range of knowledge in several work related areas such as goal setting, clear and effective communication, collaboration skills, and personal strengths. Students will develop soft workplace skills to experience new success in their current or prospective job setting.

Esta clase le dará las herramientas necesarias para aplicar aun trabajo y le ayudara como llevar a cabo una entrevista, administrar el tiempo, sobrellevar el estrés y crear ética laboral.

### AED 22.06 - 0.0 UNIT CAREER SKILLS

Not Transferable

30446	8:30-10:40AM	TTh	Morales,L	CB101
	Class# 30446 meets 09/08/2020-12/17/2020			
30447	6:30- 8:40PM	TTh	Lopez,A	CB102
	Class# 30447 meets 09/08/2020-12/17/2020			
29555	9:00-12:50PM	TTh	Mansell,B	COCC*
	Class# 29555 meets 10/20/2020-12/17/2020			

## OCCUPATIONAL TRAINING

Occupational Training will enhance students' skills to enter a new job position and/ or advance in their current work. The goal of the course is to advance students' technical skills to apply for a new job or to acquire a job advancement.

Este entrenamiento le ayudara al estudiante a mejorar sus habilidades para empezar un nuevo trabajo o ascender de posición en el área laboral. La meta de este curso es proporcionar al estudiante con las herramientas técnicas para aplicar a un nuevo trabajo o lograr crecimiento profesional

### AED 36.06 - 0.0 UNIT OCCUPATIONAL TRAINING

Not Transferable

29558	6:00- 7:50PM	MW	Martinez,D	SNPK*
30688	8:30-10:20AM	TTh	Correa,R	FISA*
29562	6:00- 8:15PM	MW	Lopez,A	CB102
	Class# 29562 meets 09/09/2020-12/16/2020			
29563	9:00-12:50PM	TTh	Mansell,B	COCC*
	Class# 29563 meets 10/20/2020-12/17/2020			

## GENERAL EDUCATION DEVELOPMENT (GED)

This GED course consists of five examinations in the areas of writing skills, social studies, science, literature, the arts and mathematics. This course will prepare students to take the battery of GED tests.

Este curso consiste en cinco materias que son escritura, ciencias sociales, literatura, arte y matematicas. Estas clases lo capacitan para pasar el examen y obtener su certificado de preparatoria.

### AED 42.10 - 0.0 UNIT SPANISH GED TEST PREP-A

Not Transferable

28060	8:30-11:20AM	MW	Correa,R	BELL*
22895	9:00-11:50AM	TTh	Rosales,I	LKMS*
30439	10:30- 1:20PM	TTh	Chavez-De Vasquez,A	FISA*
30440	8:30- 2:55PM	Sat	lachetta,C	SNPK*
	Class# 30440 meets 08/22/2020-12/12/2020			
30441	8:30- 2:55PM	Sat	Chavez-De Vasquez,A	CE 2
	Class# 30441 meets 08/22/2020-12/12/2020			

### AED 42.11 - 0.0 UNIT SPANISH GED TEST PREP-B

Not Transferable

28066	10:00-12:50PM	MW	Rosales,I	CGLB*
29466	6:00- 8:50PM	MW	lachetta,C	CE 1
29467	6:30- 9:20PM	MW	Ramos,M	NOR *
29469	6:00- 8:50PM	TTh	Chavez-De Vasquez,A	COCC*
29470	9:00- 3:25PM	F	Rosales,I	CCHA*
	Class# 29470 meets 08/21/2020-12/11/2020			
29471	8:30- 2:55PM	Sat	Nava,D	CE 6
	Class# 29471 meets 08/22/2020-12/12/2020			

### AED 42.12 - 0.0 UNIT GED PREPARATION-A

Not Transferable

29674	6:30- 9:20PM	TTh	Lealiiee,J	SL107
30438	6:00- 9:30PM	MW	Lealiiee,J	SL109
	Class# 30438 meets 09/09/2020-12/16/2020			
30436	9:00- 3:25PM	F	Morales,L	CE 6
	Class# 30436 meets 08/21/2020-12/11/2020			
30437	8:30- 2:55PM	Sat	Lealiiee,J	CE 1
	Class# 30437 meets 08/22/2020-12/12/2020			

## LITERACY SKILLS FOR GENERAL EDUCATION DEVELOPMENT

This course is designed to provide students with additional instruction and support to pass the Reasoning Through Language Arts (RLA) subtest of the General Education Development (GED) exam. Students will learn test-taking skills, understand the official General Education Development (GED) RLA test format, and complete practice General Education Development (GED) RLA tests. All subject areas of GED will be covered

Este curso está diseñado para ofrecerle al estudiante instrucción adicional y ayudarlo a pasar el pre-examen en GED de la materia "Pensamiento crítico en el arte del lenguaje" (RLA). El estudiante tambien aprender.

### AED 42.20 - 0.0 UNIT LITERACY SKILLS FOR GENERAL EDUCATION DEVELOPMENT (GED) SUCC

Not Transferable

29464	11:00- 3:50PM	M	Oviedo,A	CE 6
	Class# 29464 meets 09/14/2020-12/14/2020			
29473	8:30- 1:00PM	T	Oviedo,A	CE 7
	Class# 29473 meets 09/08/2020-12/15/2020			
29474	11:00- 3:50PM	W	Oviedo,A	CE 7
	Class# 29474 meets 09/09/2020-12/16/2020			
29475	8:30- 1:20PM	Th	Oviedo,A	SL109
	Class# 29475 meets 09/10/2020-12/17/2020			

If a class displays as **REMOTE** in the schedule, students will be expected to log into the class at a specified day/time (e.g., MW 8-9:15am). If the class displays as **ONLINE** in the schedule, students are permitted to log into the class whenever they are available to complete coursework by the established deadlines.

Students not in attendance or late for the first class meeting are subject to drop.

Class#	Time	Day	Instructor	Room	Class#	Time	Day	Instructor	Room
<b>AED 42.21 - 0.0 UNIT SPANISH LITERACY SKILLS FOR GENERAL EDUCATION DEVELOPMENT (GED)</b>					<b>28294 7:00- 8:10PM TTh</b> Carino,J Class# 28294 meets 08/17/2020-12/18/2020				
Not Transferable					<b>28295 8:10- 9:10PM TTh</b> Carino,J Class# 28295 meets 08/17/2020-12/18/2020				
28077	11:00- 3:50PM	M	lachetta,C	CE 1	<b>AED 90.01 - 0.0 UNIT INTRODUCTION TO ENERGY SURVEYING</b>				
Class# 28077 meets 09/14/2020-12/14/2020					Not Transferable				
29456	8:30- 1:00PM	T	Ramos,M	SL107	29783	7:30-11:30AM	MTWThF	Rosales,I	MSH
Class# 29456 meets 09/08/2020-12/15/2020					Class# 29783 meets 08/24/2020-08/28/2020				
29457	11:00- 3:50PM	W	lachetta,C	CE 2	29784	11:30- 3:30PM	MTWThF	Rosales,I	MSH
Class# 29457 meets 09/09/2020-12/16/2020					Class# 29784 meets 08/24/2020-08/28/2020				
29458	8:30- 1:20PM	Th	Ramos,M	CE 6	29838	7:30-11:30AM	MTWThF	Rosales,I	MSH
Class# 29458 meets 09/10/2020-12/17/2020					Class# 29838 meets 10/19/2020-10/23/2020				
					29839	11:30- 3:30PM	MTWThF	Rosales,I	MSH
					Class# 29839 meets 10/19/2020-10/23/2020				

## SUPPLEMENTAL GENERAL EDUCATION DEVELOPMENT (GED MATH)

This course is for students who need additional instruction and support in order to pass the math subtest of the General Education Development (GED) exam. Students will learn test taking skills, understand the official General Education Development (GED) math test format, and complete practice. General Education Development (GED) math tests.

Esta clase es para estudiantes que necesitan una instrucción adicional y apoyo para pasar el pre-examen de matematicas del GED. Los estudiantes aprenderán las habilidades para tomar un examen, entender el examen general del GED, el formato del examen de matematicas y completar la práctica del examen de matematica en general.

<b>AED 42.22 - 0.0 UNIT SUPPLEMENTAL GENERAL EDUCATION DEVELOPMENT (GED) MATH</b>				
Not Transferable				
28079	8:30-10:45AM	MW	Samel,C	CE 7
Class# 28079 meets 09/09/2020-12/16/2020				
28223	12:30- 2:40PM	TTh	Carranza,E	CE 1
Class# 28223 meets 09/08/2020-12/17/2020				

<b>AED 42.23 - 0.0 UNIT SPANISH SUPPLEMENTAL GENERAL EDUCATION DEVELOPMENT (GED) MAT</b>				
Not Transferable				
28119	8:30-10:45AM	MW	Ortiz,L	CE 6
Class# 28119 meets 09/08/2020-12/17/2020				
29459	12:30- 2:40PM	TTh	STAFF	CE 2
Class# 29459 meets 09/08/2020-12/17/2020				

## PRE-ALGEBRA SKILLS

The concepts of this course will help students build skills and understanding in topics related to Pre-Algebra. Students will receive support in understanding integers, fundamentals of Algebra, solving equations with fractions and/or decimals, percent, and introduction to the Cartesian coordinate system. Students will gain conceptual knowledge and use analytical thinking to solve problems. The combination lecture/lab format will provide a foundation for Pre-Algebra.

Los conceptos de este curso ayudarán a los estudiantes a desarrollar habilidades y comprensión en temas relacionados con Pre-Álgebra. Los estudiantes recibirán apoyo para comprender enteros, fundamentos de álgebra, resolver ecuaciones con fracciones y / o decimales, porcentaje e introducción al sistema de coordenadas cartesianas. Los estudiantes obtendrán conocimiento conceptual y usarán el pensamiento analítico para resolver problemas. La combinación de formato conferencia / laboratorio proporcionará una base para Pre-Álgebra.

<b>AED 42.99 - 0.0 UNIT PRE-ALGEBRA SKILLS</b>				
Not Transferable				
28288	11:00-12:00PM	MW	Barrera De Contreras	MP103
Class# 28288 meets 08/17/2020-12/18/2020				
28289	12:00-12:50PM	MW	Barrera De Contreras	MP103
Class# 28289 meets 08/17/2020-12/18/2020				
28641	8:00-10:10AM	Sat	Barrera De Contreras	MP105
Class# 28641 meets 08/17/2020-12/18/2020				
28642	10:10-12:15PM	Sat	Barrera De Contreras	MP105
Class# 28642 meets 08/17/2020-12/18/2020				

## AED 90.02 - 0.0 UNIT BASIC ELECTRICITY AND WIRING FUNDAMENTALS

Not Transferable				
Prerequisite: AED 90.01 with a grade of "C" or higher or "Pass".				
29788	7:30-11:30AM	MTWThF	Rosales,I	MSH
Class# 29788 meets 09/08/2020-09/11/2020				
29789	11:30- 3:30PM	MTWThF	Rosales,I	MSH
Class# 29789 meets 09/08/2020-09/11/2020				
29840	7:30-11:30AM	MTWThF	Rosales,I	MSH
Class# 29840 meets 11/02/2020-11/06/2020				
29841	11:30- 3:30PM	MTWThF	Rosales,I	MSH
Class# 29841 meets 11/02/2020-11/06/2020				

## AED 90.03 - 0.0 UNIT INTRO TO LIGHTING RETROFITS

Not Transferable				
29790	7:30-11:30AM	MTWThF	Rosales,I	MSH
Class# 29790 meets 09/14/2020-09/18/2020				
29791	11:30- 3:30PM	MTWThF	Rosales,I	MSH
Class# 29791 meets 09/14/2020-09/18/2020				
29842	7:30-11:30AM	MTWThF	Rosales,I	MSH
Class# 29842 meets 11/16/2020-11/20/2020				
29843	11:30- 3:30PM	MTWThF	Rosales,I	MSH
Class# 29843 meets 11/16/2020-11/20/2020				

## AED 90.05 - 0.0 UNIT OSHA-10 TRAINING

Not Transferable				
29836	7:30-11:30AM	WTh	Rosales,I	MSH
Class# 29836 meets 10/14/2020-10/15/2020				
29837	11:30- 3:30PM	WTh	Rosales,I	MSH
Class# 29837 meets 10/14/2020-10/15/2020				
29844	7:30-11:30AM	WTh	Chaboya,R	MSH
Class# 29844 meets 12/09/2020-12/11/2020				
29845	11:30- 3:30PM	WTh	Chaboya,R	MSH
Class# 29845 meets 12/09/2020-12/11/2020				

If a class displays as **REMOTE** in the schedule, students will be expected to log into the class at a specified day/time (e.g., MW 8-9:15am). If the class displays as **ONLINE** in the schedule, students are permitted to log into the class whenever they are available to complete coursework by the established deadlines.

Students not in attendance or late for the first class meeting are subject to drop.

Class#	Time	Day	Instructor	Room	Class#	Time	Day	Instructor	Room
--------	------	-----	------------	------	--------	------	-----	------------	------

## MATH SUPPORT: STATISTICS

This course will provide additional support for Introductory Statistics. This course is for students who desire greater self-confidence and wish to improve math skills. Students will develop a range of knowledge in pre-statistics. Students will gain conceptual knowledge and use analytical thinking to solve problems. The combination lecture/lab format will provide a foundation for introductory statistics. Recommended non-credit support for Math 75 or Math 112. This course is open entry/open exit.

Esta clase provee soporte adicional para la clase introductoria de estadísticas. La clase es para estudiantes que buscan mejorar sus habilidades en matemáticas y quieren ese soporte extra para clase. Los estudiantes que atiendan desarrollaran un rango de habilidades en estadísticas. Conceptos de análisis crítico y solución de problemas. Formato de lectura con laboratorio provee a una fundación para las clases de introducción a estadísticas. Recomendado clase sin crédito para Math 75 o Math 112. Esta clase es de inscripción abierta.

### AED 90.06 - 0.0 UNIT MATH SUPPORT: STATISTICS

Not Transferable

30452	11:00-12:00PM	W	Ortiz,L	MP104					
	Class# 30452 meets 08/17/2020-12/18/2020								
30453	12:00-12:50PM	W	Ortiz,L	MP104					
	Class# 30453 meets 08/17/2020-12/18/2020								
30454	1:00- 2:00PM	W	Ortiz,L	MP103					
	Class# 30454 meets 08/17/2020-12/18/2020								
30455	2:00- 2:50PM	W	Ortiz,L	MP103					
	Class# 30455 meets 08/17/2020-12/18/2020								
30456	12:00-12:30PM	TTh	Ortiz,L	MP103					
	Class# 30456 meets 08/17/2020-12/18/2020								
30457	12:30-12:50PM	TTh	Ortiz,L	MP103					
	Class# 30457 meets 08/17/2020-12/18/2020								
<b>30458</b>	<b>4:30- 5:30PM</b>	<b>TTh</b>	<b>Ortiz,L</b>	<b>MP103</b>					
	Class# 30458 meets 08/17/2020-12/18/2020								
<b>30459</b>	<b>5:30- 6:20PM</b>	<b>TTh</b>	<b>Ortiz,L</b>	<b>WD 1</b>					
	Class# 30459 meets 08/17/2020-12/18/2020								
30460	9:00- 9:30AM	TTh	Ortiz,L	MP103					
	Class# 30460 meets 08/17/2020-12/18/2020								
30461	9:30- 9:50AM	TTh	Ortiz,L	MP103					
	Class# 30461 meets 08/17/2020-12/18/2020								
30462	3:00- 3:30PM	TTh	Carranza,E	MP105					
	Class# 30462 meets 08/17/2020-12/18/2020								
30463	3:30- 3:50PM	TTh	Carranza,E	MP105					
	Class# 30463 meets 08/17/2020-12/18/2020								
<b>30464</b>	<b>5:00- 6:00PM</b>	<b>TTh</b>	<b>Carranza,E</b>	<b>MP104</b>					
	Class# 30464 meets 08/17/2020-12/18/2020								
<b>30465</b>	<b>6:00- 6:50PM</b>	<b>TTh</b>	<b>Carranza,E</b>	<b>MP104</b>					
	Class# 30465 meets 08/17/2020-12/18/2020								

## MATH SUPPORT: COLLEGE ALGEBRA

This course is a math support course. This course is for students who desire greater self-confidence and wish to improve their algebra skills. Students will build pre - college level math skills to prepare for college algebra. Students will gain conceptual knowledge and use analytical thinking to solve problems. The combination lecture/lab format will provide a foundation for college algebra. Recommended non-credit support for Math 60, Math 80, or Math 114. This course is open entry/open exit.

Esta es una clase de soporte para matemáticas. El curso está diseñado para estudiantes que quieran adquirir confianza en sus habilidades y deseen mejorar sus habilidades en algebra. Estudiantes obtendrá las habilidades necesarias para pre algebra para estar listo para algebra en el colegio. Estudiantes aprenderán conceptos de análisis y como resolver problemas. Recomendado clase de soporte sin credito para Math 60, Math 80 o Math 114. Esta clase es de inscripción abierta.

### AED 90.07 - 0.0 UNIT MATH SUPPORT: COLLEGE ALGEBRA

Not Transferable

30466	10:00-12:00PM	MW	Takeuchi,K	AT 54					
	Class# 30466 meets 08/17/2020-12/18/2020								
30467	12:00-12:50PM	MW	Takeuchi,K	AT 54					
	Class# 30467 meets 08/17/2020-12/18/2020								

30468	10:00-11:00AM	TTh	Ortiz,L	AT 54					
	Class# 30468 meets 08/17/2020-12/18/2020								
30469	11:00-11:50AM	TTh	Ortiz,L	AT 54					
	Class# 30469 meets 08/17/2020-12/18/2020								
30470	1:00- 2:00PM	TTh	Ortiz,L	WD 1					
	Class# 30470 meets 08/17/2020-12/18/2020								
30471	2:00- 2:50PM	TTh	Ortiz,L	WD 1					
	Class# 30471 meets 08/17/2020-12/18/2020								
<b>30472</b>	<b>6:30- 7:20PM</b>	<b>TTh</b>	<b>Ortiz,L</b>	<b>MP105</b>					
	Class# 30472 meets 08/17/2020-12/18/2020								
<b>30473</b>	<b>7:20- 7:50PM</b>	<b>TTh</b>	<b>Ortiz,L</b>	<b>MP105</b>					
	Class# 30473 meets 08/17/2020-12/18/2020								
30474	9:00-11:20AM	Sat	Carino,J	WD 1					
	Class# 30474 meets 08/17/2020-12/18/2020								
30475	11:20- 1:20PM	Sat	Carino,J	WD 1					
	Class# 30475 meets 08/17/2020-12/18/2020								
30476	9:00-10:00AM	MW	Herrera,M	MC101					
	Class# 30476 meets 08/17/2020-12/18/2020								
30477	10:00-10:50AM	MW	Herrera,M	MC101					
	Class# 30477 meets 08/17/2020-12/18/2020								
30478	2:00- 3:00PM	MW	Carranza,E	MC104					
	Class# 30478 meets 08/17/2020-12/18/2020								
30479	3:00- 3:50PM	MW	Carranza,E	MC104					
	Class# 30479 meets 08/17/2020-12/18/2020								

## APPRENTICESHIP PROGRAMS

Learn a trade while you work. Apprenticeship is a well-organized and supervised method of training individuals who have little or no knowledge of the craft.

Cerritos College has 3 apprenticeship programs:  
Field Ironworkers  
SC/PDCA Painters & Decorators of California

For further information call (562) 860-2451, ext. 2497

## PLAZA COMMUNITARIA

The Office of Adult Education & Diversity Programs in collaboration with the Mexican Consulate in Los Angeles offers an innovative new program called Plaza Comunitaria. The program consists of three levels of progression which teach the Spanish speaking adults to read, write and speak in their native tongue and to complete their first and secondary education. At the completion of this program the student will receive a diploma from the Secretary of Public Education from Mexico. Our goal is to transition the student into regular ESL courses with a higher rate of success and then introduce them to a higher level of education.

El Departamento de Educación de Adultos y Programas Diversos en colaboración con el Consulado Mexicano de Los Angeles ofrecemos un nuevo e innovador programa "Plaza Comunitaria." La Plaza Comunitaria es un programa que consiste tres niveles que permite que los adultos de habla Español aprendan leer y escribir en su lengua natal y acabar su educación primaria y secundaria. Al terminar cada nivel, el estudiante recibe un diploma de la Secretaria de Educación Publica en México. Al terminar su educación secundaria los estudiantes son capaces a la transición en cursos de ESL con un índice mas alto de éxito.

For further information call (562) 860-2451, ext. 2518

## FOSTER KINSHIP CARE PROGRAM

The workshops offered through Cerritos College help to enhance and develop parenting skills related to caring for both foster children and children in a relatives care. As a licensed foster parent, you are required to obtain continuing education hours every year, and the classes we offer at Cerritos College through the FKCE program fill these requirements.

For further information call (562) 860-2451, ext. 2548

If a class displays as **REMOTE** in the schedule, students will be expected to log into the class at a specified day/time (e.g., MW 8-9:15am). If the class displays as **ONLINE** in the schedule, students are permitted to log into the class whenever they are available to complete coursework by the established deadlines.

Students not in attendance or late for the first class meeting are subject to drop.



# CHICANO STUDIES

## WHY STUDY CHICANO STUDIES?

The Mexican American/Chicano(a)/Latinx Department seeks to increase critical understanding and appreciation of social, historical, and continuing cultural significance of Mexican American and Latinx communities. The Latinx population has played an important role in shaping our nation's history and is now the fastest growing population in the United States, and will soon become the majority population in the state of California. Students who major in Chicano Studies will enroll in classes from a variety of disciplines that enrich their understanding of the experiences and contributions of Mexican Americans and Latino[a]s past and present. The Chicano Studies Associate in Arts Degree requires completion of courses from the fields of History, Art, Women's Studies, Sociology, Philosophy, Psychology, Spanish, English, and Anthropology.

Chicano Studies courses are vital to help you learn, value, and practice cultural competence – an imperative and beneficial skill to build in an increasingly diverse society. Chicano Studies courses will help you gain more self-confidence and improved self-esteem to experience new ways of learning, as course framework reflects that of historically marginalized groups that are often overlooked.

## IF YOU TAKE COURSES IN CHICANO STUDIES, YOU WILL:

- Gain understanding of the importance of Chicano(a)/ Latinx culture in the United States.
- Analyze and evaluate the contributions of Chicano(a)s and Latinx within US society in diverse disciplines such as Politics, Science, Health, Education, Social Sciences, Humanities, Music, and Fine Arts.
- Be introduced to significant Mexican American, Chicano, and Latino leaders in the US, both new and contemporary figures, as a form of mentorship. Learning about these leaders will help you advance further in your personal, academic, and professional lives.
- Become active in today's society to procure benefits for your education and for the benefit of others in your community.

The Associate in Arts Degree in Chicano Studies prepares students to transfer to California State University (CSU) campuses that offer Chicano Studies. In addition, Chicano Studies is an interdisciplinary program that contains a wide array of classes from English, Spanish, History, Social Science, Fine Arts, Women Studies, and Anthropology. All of these major courses of study will also prepare the student to obtain additional coursework to major and/or minor in the disciplines mentioned above. The degree requires students to complete 60 CSU transferable units.

## There are many careers in which a Chicano Studies degree is beneficial:

- Arts, Fine Arts, & Music
- Community Organizing
- English
- Foreign Service
- Journalism
- Marketing & Public Relations
- Medical Profession
- Public & Business Administration
- Law
- Law Enforcement
- Librarian/Historian
- Non-Profit Organization
- Public Policy
- Social Work
- Teaching: K-12, Credentialing, & Higher Education

## MAJOR REQUIREMENTS:

Required Courses	(19 units)	Elective Courses (choose two courses)	(6–9 units)
ENGL 223 Chicana/Chicano Literature	3.0	ANTH 100 Cultural Anthropology	3.0
ENGL 225 Mexican Literature in Translation	3.0	ANTH 170 Introduction to Language and Culture	3.0
SPAN 101 Elementary Spanish	3.0	ANTH 202 The Mayans, Incans, and Aztecs: Ancient Civilizations of the Americas	3.0
or SPAN 111 Elementary Spanish for Spanish Speakers	(5.0)	ART 105A The Arts of Latin America and the Caribbean: Pre-Colombian	3.0
SPAN 102 Elementary Spanish	5.0	ART 105B The Arts of Latin America and the Caribbean: Colonial to the Present	3.0
or SPAN 112 Elementary Spanish for Spanish Speakers	(5.0)	COUN 150 Dynamics of Leadership	3.0
SPAN 245 Introduction to Chicano/Mexican American Culture	5.0	HIST 120 History of California	3.0
		HIST 230 History of Mexico	3.0
		HIST 235 History of Latin America	3.0
		HO 100 Health of Underserved Communities	3.0
		HUM 108 Black Images in Popular Culture	3.0
		or ART 108 Black Images in Popular Culture	(3.0)
		INST 100 Principles and Strategies for Problem Solving	3.0
		PHIL 104 Philosophy of Cultural Diversity: Challenge and Change	3.0
		PHIL 200 World Religions	3.0
		PSYC 261 Social Psychology	3.0
		SOC 201 Social Problems	3.0
		SOC 215 Sociology of Cultural Diversity, Challenge and Change	3.0
		SOC 210 American Minority Relations	3.0
		SPAN 201 Intermediate Spanish	5.0
		SPAN 202 Intermediate Spanish	4.0
		SPAN 210 Highlights of Hispanic Culture	3.0
		WGS 101 Issues for Women in American Society	3.0
		WGS 105 Gender Studies and the Chicana/Latina Experience	3.0

ASSOCIATE IN ARTS DEGREE REQUIREMENTS: Complete the following (1) major requirements, (2) the A.A. Degree General Education requirements, and (3) electives to achieve a minimum of 60 units.

	AA	CSU	IGETC
Major Total:	25-28 units	25-28 units	25-28 units
GE Pattern: AA, CSU, and IGETC:	18 units	18 units	37 units
Double Counted Units:	0	12	18
Degree applicable electives (as needed): (CSU and IGETC requires CSU transferable units)	42 units	5-7 units	13-16 units
Total Degree Units (Maximum):	60 units	60 units	60 units

**Total Major Requirements:**

**25 – 28**



# SCHOLARS' HONORS PROGRAM

## WHAT IS THE SCHOLARS' HONORS PROGRAM?

The Scholars' Honors Program (SHP) is a social and academic home that Cerritos College offers to talented and motivated students planning to transfer to four-year colleges and universities, especially to the UC and CSU systems. It introduces you to a community of faculty and staff who are committed to helping you succeed, and it provides you with a supportive environment of fellow students with similar goals and interests.

## AM I ELIGIBLE FOR THE SHP?

- A cumulative GPA of 3.0 in all coursework
- Readiness for English 100 (Freshman Composition)

## HOW DO I JOIN?

Go online to the SHP web page, <http://www.cerritos.edu/shp>.

### HONORS COURSES, FALL SESSION, 2020

<b>Art 207: or WGS 207</b>	<b>Gender and Sexuality in Art</b> <b>Gender and Sexuality in Art</b> Prof. Julie Trager (9 weeks) UC/CSU: Fulfills IGETC Humanities Requirement (Plan C: 3B)	Class #29079 Class #29113
<b>Communications 110:</b>	<b>Intercultural Communication</b> Prof. Angela Hoppe-Nagao (1st 9 weeks) Prof. Angela Hoppe-Nagao (2nd 9 weeks) UC/CSU: Fulfills an IGETC Social & Behavioral Sciences requirement (Plan C: Area 4)	Class #25632 Class #25633
<b>Earth Science 104:</b>	<b>Oceanography</b> Prof. Dan DeKraker UC/CSU: Fulfills an IGETC Physical & Biological Sciences requirement (Plan C: Area 5A)	Class #21885
<b>Economics 201M:</b>	<b>Principles of Macroeconomics</b> Prof. Solomon Namala (15 weeks) UC/CSU: Fulfills an IGETC Social & Behavioral Sciences requirement (Plan C: Area 4)	Class #24440
<b>English 100:</b>	<b>Freshman Composition</b> Prof. Timothy Juntilla (15 weeks) Prof. Timothy Juntilla (15 weeks) UC/CSU: Fulfills the IGETC Freshman Composition requirement (Plan C: Area 1A)	Class #26399 Class #20193
<b>English 103:</b>	<b>Critical and Argumentative Writing</b> Prof. Nicole Lovejoy-Robold (15 weeks) UC/CSU: Fulfills the IGETC Critical Thinking requirement. (Plan C: Area 1B)	Class #26408
<b>English 110:</b>	<b>Critical Thinking Through Literature</b> Prof. Daniel Gardner UC/CSU: Fulfills the IGETC Critical Thinking requirement (Plan C: Area 1B)	Class #29212
<b>Humanities 100:</b>	<b>The Art of Being Human</b> Prof. Julie Trager (9 weeks) UC/CSU: Fulfills IGETC Humanities Requirement (Plan C: 3B)	Class #28036
<b>Psychology 210:</b>	<b>Elementary Statistics</b> Prof. Jaclyn Ronquillo-Adachi UC/CSU: Fulfills an IGETC Math Concepts & Quan. Reasoning requirement (Plan C: Area 2)	Class #24469
<b>Sociology 202: or WGS 202</b>	<b>Gender and Society</b> <b>Gender and Society</b> Prof. Amy Holzgang (9 weeks) UC/CSU: Fulfills an IGETC Social & Behavioral Sciences requirement (Plan C: Area 4)	Class #30639 Class #30638
<b>Sociology 205:</b>	<b>Introduction to Social Research Methods</b> Prof. Amy Holzgang (15 weeks) UC/CSU: Fulfills an IGETC Social & Behavioral Sciences requirement (Plan C: Area 4)	Class #26209

**NOTE:** Two of the honors courses are cross-listed; in other words, they are the same course and fulfill the same requirement, but you decide how it will appear on your transcript.

- **ART 207 or WGS 207:** your choice of it appearing as an Art course or a Humanities course. Either way, it fulfills the exact same requirement.  
(Plan C: Area 3B)
- **SOC 202 or WGS 202:** your choice of it appearing as a Sociology course or a Women & Gender Studies course. Either way, it fulfills the exact same requirement.  
(Plan C: Area 4)

# WOMEN'S AND GENDER STUDIES DEPARTMENT

## FALL 2020 CLASSES

**Schedule in subject to change. For more information please contact,  
Amy Holzgang and Michelle Fagundes, Co-Chairs, Women's and Gender Studies Department.**

"Gender equality is a shared vision of social justice and human rights"  
*United Nations' Women Executive Director Phumzile Mlambo-Ngcuka*

"Culture does not make people. People make culture. If it is true that the  
full humanity of women is not our culture, then we can and must make it our culture."  
*Chimamanda Ngozi Adichie, (Nigerian author, awarded a MacArthur  
Genius Grant in 2018 and author of We Should All Be Feminists, 2015.)*

### **Women's and Gender Studies 101 (WGS 101)** ***Issues for Women in American Society***

Transferable to UC and CSU.

Class #20606 Michelle Fagundes ONLINE ONLINE  
Class #25739 Mariam Youssef ONLINE ONLINE

### **Women's and Gender Studies 102 (WGS 102)** ***Women and Religion***

Transferable to CSU.

Class #26452 Mariam Youssef ONLINE ONLINE  
Class #29108 Mariam Youssef ONLINE ONLINE

### **Women's and Gender Studies 103 (WGS 103)** ***Women, their Bodies and Health***

Transferable to UC and CSU.

Class #30665 Elizabeth Gusman ONLINE ONLINE

#### **Nine Week Session B7 T/TH Session (10/20/2020 - 12/17/2020)**

Class #27430 Pauline Acosta T/TH 6:30 – 9:20 pm

### **Women's and Gender Studies 105 (WGS 105)** ***Gender Studies and Chicana/Latina(x)***

Transferable to UC and CSU.

#### **Fifteen Week Session B7 T/TH Session (9/8/2020 – 12/17/2020)**

Class #27754 Pauline Acosta T/TH 5:00 – 6:30 pm

### **Women's and Gender Studies 108 (WGS 108)** ***Women in Sports***

Transferable to UC and CSU.

Class #27286 Trisha Kozlowski ONLINE ONLINE

#### **Nine Week Session B M-F Session (10/19/2020 - 12/18/2020)**

Class #27400 Trisha Kozlowski ONLINE ONLINE

### **Women's and Gender Studies 115 (WGS 115)** ***Gender, Communication, and the Digital Revolution***

Transferable to UC and CSU.

#### **Nine Week Session A M-F Session (8/7/2020 - 10/16/2020)**

Class #29109 Kimberly Rosenfeld ONLINE ONLINE

#### **Nine Week Session B M-F Session (10/19/2020 - 12/18/2020)**

Class #28198 Kimberly Rosenfeld ONLINE ONLINE

### **Women's and Gender Studies 118 (WGS 118)** ***History of Women in Visual Art***

Transferable to UC and CSU.

#### **Fifteen Week Session A M-F Session (8/17/2020 – 11/27/2020)**

Class #29111 Lisa Vitela ONLINE ONLINE

### **Women's and Gender Studies 140 (WGS 140)** ***Introduction to LGBT Studies***

Transferable to UC and CSU.

#### **Fifteen Week Session B M-F Session (9/8/2020 – 12/18/2020)**

Class #30390 Lance Kayser ONLINE ONLINE

### **Women's and Gender Studies 202 (WGS 202)** ***Gender and Society***

Transferable to UC and CSU.

#### **Fifteen Week Session A M-F (8/17/2020 - 11/27/2020)**

Class #29112 Holly Gregg ONLINE ONLINE

#### **Nine Week Session A M-F (8/17/2020 - 10/16/2020)**

Class #27753 Amy Holzgang ONLINE ONLINE

#### **Nine Week Session B M-F (10/19/2020 - 12/18/2020)**

Class #30638 Amy Holzgang ONLINE ONLINE

Honors

### **Women's and Gender Studies 206 (WGS 206)** ***Women in the Global Economy***

Transferable to UC and CSU.

#### **Fifteen Week Session B M-F (9/8/2020 - 12/18/2020)**

Class #29640 Katya De Los Rios ONLINE ONLINE

### **Women's and Gender Studies 207 (WGS 207)** ***Women and Media***

Transferable to UC and CSU.

#### **Nine Week Session B M-F Session (10/19/2020 - 12/18/2020)**

Class #29113 Julie Trager ONLINE ONLINE

Honors

### **Women's and Gender Studies 208 (WGS 208)** ***Leadership for Women in Business***

Transferable to CSU - All classes' information will be available at [www.cerritos.edu/baonline](http://www.cerritos.edu/baonline)

#### **Nine Week Session A M-F Session (8/17/2020 - 10/16/2020)**

Class #26384 Barbara Livingston ONLINE ONLINE

#### **Nine Week Session B M-F Session (10/19/2020 - 12/18/2020)**

Class #26385 Barbara Livingston ONLINE ONLINE

Class #26386 Barbara Livingston ONLINE ONLINE

# LEARNING COMMUNITIES

For Fall 2020, there are three Learning Communities: Puente Program, Umoja Success Program, and First Year Experience.

For more information about enrolling in the Learning Communities Program or for a complete description of each learning community, please check the website at [www.cerritos.edu/lcp/](http://www.cerritos.edu/lcp/) or call (562) 860-2451, ext. 2212.

## PUENTE PROGRAM:

The Puente Program is designed to help students achieve academic success, instills a sense of belonging, and guarantees students four transfer courses with textbooks provided at no cost. These courses are all transferrable and will get you more familiar with the transfer process, major and career decision process, and build your leadership skills. The most unique aspect of the Puente Program is that the professors approach these four subjects through a Latina/o perspective, including Latina/o authors; historical and contemporary issues in the Latina/o community; and different themes pertaining to the Latina/o community.

Through Puente, you will receive counseling, guidance, mentorship, and assistance on the importance of transferring into a CSU, UC, or private universities. The Puente Program also takes students on field trips such as visiting Northern California universities free of charge.

For more information on the Puente Program, contact the Counseling Department at (562) 467-5231.

30095	ENGL 100S	4.5 units	Gardner, D.	Online		
22519	COUN 200	3 units	Romero, G.	TTH	11:00 – 11:50 am	Remote
<b>Total Units:</b>	<b>7.5 units</b>					

Note: All students are required to take a Math class with a support AED Math class in the fall semester.

## UMOJA SUCCESS PROGRAM: THE UNITY OF KNOWLEDGE AND SELF.

Be a part of a community of scholars designed with you in mind! The Umoja Success Program assists African American students and others in achieving academic and life success through the exploration of Black Culture and Hip Hop. The program is a dynamic learning experience shared by a group of students with faculty that is committed to their success. Umoja, a place to call home!

So what's in it for you? Support, trips, free stuff, and much more. Interested students should complete the Google Doc on the Learning Communities website, and Umoja will connect with you about joining the community!

If you want to go fast, then go alone. If you're going to go far, go together! — UMOJA!

Umoja Learning Cohort Fall 2020 will have a dynamic English (ENGL 100S) composition class grounded in African American Hip-Hop culture, and participants will also have a great time connecting in the Personal and Career Success (COUN 200) course. This class is about you!

30084	ENGL 100S	4.5 units	Cagnolatti, D.	MW	11:00 am – 1:50 pm	Remote
22579	COUN 200	3 units	Hill, S.	TTH	1:00 – 2:15 pm	Remote
<b>Total Units:</b>	<b>7.5 units</b>					

Note: The Umoja Program will recommend additional classes to fill out the students' schedules.

## FIRST YEAR EXPERIENCE (FYE):

First Year Experience program (FYE) is a student success program designed to help students make a smooth and successful transition into college. FYE pairs classes together in "Houses" that focus on an area of interest or major and allows you to take these classes with a cohort of students with the same interest. FYE provides a supportive and welcoming learning community environment where students connect with one another and with creative faculty members. The FYE Houses are packaged together during convenient class times, so they work well with your schedule and are guaranteed to the first 30 students who sign a contract. FYE also has events during the semester aimed at connecting you to campus and community.

### Arts, Humanities, & Communications House

30497	COUN 200	3 units	Fisher, C.	MW	12:30 – 1:45 pm	Remote
26510	ENGL 100	4 units	Fagundes, M.	Online		
24343	MATH 112	4 units	Morales, M.	Online		
29060	MATH 5	1 unit	Morales, M.	Online		

Students can enroll in **ONE** additional class from the list below:

	ART 102/103	3 units				
	ART 110	3 units				
	COMM 100	3 units				
	COMM 120	3 units				
	MUS 105	3 units				
	PHIL 100	3 units				
<b>Total Units:</b>	<b>15 units</b>					

# LEARNING COMMUNITIES

## Health Occupations House

22518	COUN 200	3 units	Aguayo, R.	TTH	9:30 – 10:45 am	Remote
27865	ENGL 100	4 units	Mitchell-Lambert, J.	Online		
20339	MATH 112	4 units	Morales, M.	Online		
29045	MATH 5	1 unit	Morales, M.	Online		
20550	SOC 101	3 units	Holzgang, A.	Online		
<b>Total Units:</b>	<b>15 units</b>					

## Psychology House

27871	ENGL 100	4 units	Cristin, S.	Online		
20504	PSYC 101	3 units	Beas, V.	Online		
29104	PSYC 210	3 units	Beas, V.	Online		
Auto Enroll	PSYC 210 Lab	1 unit	Beas, V.	Online		
30187	READ 101	3 units	Belroy, B.	Online		
<b>Total Units:</b>	<b>14 units</b>					

## LEARNING COMMUNITIES CLASSES

Learning communities involve the intentional creation of class pairs or clusters. Typically, the same group of students is co-enrolled in two or more courses, usually from different disciplines—for instance, English and career guidance. Students enroll in both courses but receive a separate grade for each one. Classroom activities, tests, assignments, field trips, research projects, and educational technology are used to engage students in their own learning, as well as provide them with valuable “real-world” skills. Students enroll in both courses but receive a separate grade for each one.

Perhaps more importantly, the learning community model promotes student-centered learning, with an emphasis on an enriched classroom environment. It promotes greater intellectual growth and genuine mastery of course content through collaborative activities, frequent feedback, and increased student-teacher and student-student interactions.

Research indicates learning communities promote student achievement, retention, and progress toward degree completion. Faculty benefit from professional development and training, fresh approaches to teaching, and collaboration with colleagues.

## WHAT ARE THE BENEFITS OF JOINING A LEARNING COMMUNITY?

- Smooth your transition into college
- Meet other students and form lasting friendships
- Learn how to choose your major and reach your academic goals sooner
- Graduate or transfer to a four-year college or university sooner
- Increase your learning and earn better grades

## ARE LEARNING COMMUNITY COURSES TRANSFERABLE?

Many of the courses are transferable to CSUs and/or UCs. See the Schedule of Classes, the Cerritos College Catalog, or meet with a counselor to check specific courses.

## WHAT ARE THE REQUIREMENTS TO ENROLL?

- The only requirements to enroll in a Learning Community are that you:
- a) meet the prerequisites for all courses and
  - b) enroll in all courses listed for that Learning Community.

The prerequisites are listed in the Cerritos College Catalog and must be met prior to enrollment.

## HOW WILL LEARNING COMMUNITY COURSES BE LISTED ON MY TRANSCRIPT?

Your transcript will reflect the classes as separate courses.

## QUESTIONS

If you have questions about the Learning Communities Program (LCP), please call (562) 860-2451, ext. 2212.



# DISTANCE EDUCATION PROGRAM ONLINE COURSES

**For complete course descriptions, see the regular course listings in the schedule of classes.**

## WHAT IS DISTANCE EDUCATION?

Distance Education takes place when a teacher and students are separated by physical distance. In place of traditional classroom delivery; voice, video, data, and print are used. Cerritos College offers online, remote, and hybrid courses (see definitions in next column). All courses carry full academic credit and their content is equivalent to what you would receive in a more traditional mode of delivery.

## WHAT SKILLS ARE REQUIRED FOR ONLINE LEARNING?

In order to support student success in online classes, students and faculty should be aware of core skills and expectations that promote student achievement in an online learning environment. For students who are interested in taking an online class for the first time, please review the following list of necessary skills and learning expectations. Contact the instructor of the course directly to ask if there is an orientation module that you can take for that class.

### Necessary Student Skills:

1. Basic Computer skills (send and receive email and attachments; download files; fundamentals of file management; search and navigate the Internet using a browser)
2. Awareness of institutional support services (Student Success Centers)
3. Successful completion of prerequisite coursework
4. Organizational skills
5. Reading comprehension
6. Writing skills
7. Communication skills
8. Time-management skills
9. Proficiency in any adaptive computing software/hardware needed to access the online course material when there is a disability-related barrier
10. Recommended completion of online orientation (such as EDT 50) or equivalent preparation
11. Familiarity with college course management system (such as Canvas)

### Student Learning Expectations:

1. Motivated and focused
2. Awareness of online expectations, environment and workload
3. Autonomous, self-motivated learner
4. Positive attitude toward technology
5. Intention to complete the course
6. Ability to work independently
7. Ability to work as a group member
8. Having the confidence to follow directions and to ask for assistance

Before registering for any online course, you should make sure that you have proficient skills in basic computing, web browsing, email, and word processing. Your instructor will not teach these skills as part of the course content. If you do not possess these skills, you may want to enroll in EDT 50: Preparation for Online Learning, or CIS 50: Basic Computer Literacy.

## WHAT ARE THE TYPES OF ONLINE INSTRUCTION?

The class schedule refers to courses as “online”, “remote”, or “hybrid”. All students who register for an online, remote, or hybrid class should log in to the Canvas site for additional information about class meetings and course requirements. Access to email and the Internet are required to complete work using email, chat rooms, discussion boards, and other instructional tools.

**Online.** While restrictions to entering campus remain for COVID-19, courses designated as “online”, or OL, Online courses occur fully online. There is no specific class time that students are required to log in. Students are permitted to log in to the class via Canvas whenever students are available to complete coursework. However, students must log in for the first time before the census date for the class (see Important Add/Drop Dates on the Admissions & Records web page. Students must also complete all assignments by the deadlines established by the class instructor.

**Remote.** If a class displays as “remote” in the schedule, instruction occurs fully online. Students are expected to log into the class via Canvas at a specified day and time, such as MW 8 – 9:15 am. Students also must complete all assignments by the deadlines established by the class instructor.

**Hybrid.** These courses include the combination of traditional face-to-face instruction with online instruction. Therefore, students will be required to attend on-campus meetings as scheduled by the instructor, as well as complete work using email, the campus course management system (Canvas) and/or chat rooms, discussion boards, and other instructional tools. These courses are designated as HYBRID in the published class schedule.

## ENROLLING IN AN ONLINE COURSE?

Students enroll in online sections in the same manner as regular classes. Consult the general enrollment procedures in this schedule for more information.

## ACCESSING ONLINE AND HYBRID COURSES:

Once you are enrolled in a class, go to the Canvas website, [www.cerritos.edu/canvas](http://www.cerritos.edu/canvas), and log on with your username and password.

**Username:** This is your 7-digit student ID number. Example: John Smith, ID #1234567. Your ID number, 1234567, is your username.

**Password:** Your initial password is your 8-digit date of birth in the “mmddyyyy” format. Example: John Smith's date of birth is May 30, 1990. His password would be 05301990.

## ONLINE ORIENTATION:

Each online course includes a brief orientation either online or on campus. Check course listings for information. **You must attend any orientations and/or contact your instructor prior to the 1st week of class or you may be dropped.** If the orientation for online class conflicts with a class that meets on campus, you must attend the on-campus class and notify the online instructor about the time conflict in advance. Go to [www.cerritos.edu/de](http://www.cerritos.edu/de) for more information.

### FOR ASSISTANCE CONTACT THE SUCCESS CENTER CHAT

at <http://www.cerritos.edu/sc>

Email: [de-info@cerritos.edu](mailto:de-info@cerritos.edu) or

visit the DE home page at <http://www.cerritos.edu/de>

# DISTANCE EDUCATION COURSES

## ONLINE COURSES

Most work and communications occur online. Access to email and the Internet is required. Orientations are mandatory.

### ACCOUNTING

21945	ACCT 60	Quickbooks Accounting
21950	ACCT 61	Turbo Tax Accounting
21951	ACCT 61	Turbo Tax Accounting
21907	ACCT 100	Introduction to Accounting
23561	ACCT 100	Introduction to Accounting
27141	ACCT 100	Introduction to Accounting
24408	ACCT 100	Introduction to Accounting
21911	ACCT 100	Introduction to Accounting
21948	ACCT 100	Introduction to Accounting
21914	ACCT 101	Fundamentals of Accounting I
21915	ACCT 101	Fundamentals of Accounting I
21916	ACCT 101	Fundamentals of Accounting I
21917	ACCT 101	Fundamentals of Accounting I
21922	ACCT 101	Fundamentals of Accounting I
21923	ACCT 101	Fundamentals of Accounting I
21928	ACCT 102	Fundamentals of Accounting II
21929	ACCT 102	Fundamentals of Accounting II
21930	ACCT 102	Fundamentals of Accounting II
21931	ACCT 102	Fundamentals of Accounting II
21934	ACCT 102	Fundamentals of Accounting II
21935	ACCT 102	Fundamentals of Accounting II
21936	ACCT 130	Payroll Tax Accounting
21937	ACCT 131	Computerized Accounting - IBM
21940	ACCT 133	Spreadsheet Accounting I
21938	ACCT 133	Spreadsheet Accounting I
28138	ACCT 220	Accounting Ethics
21943	ACCT 240	Cost Accounting
21944	ACCT 240	Cost Accounting
29090	ACCT 250	Income Tax Accounting
27768	ACCT 270	Fundamentals of Auditing

24578	ASL 110	American Sign Language I
24579	ASL 110	American Sign Language I
24580	ASL 110	American Sign Language I
24581	ASL 110	American Sign Language I
24582	ASL 110	American Sign Language I
24583	ASL 110	American Sign Language I
30400	ASL 111	American Sign Language II
30401	ASL 111	American Sign Language II
30402	ASL 211	American Sign Language IV
30403	ASL 211	American Sign Language IV
28153	ASL 215	Beginning Interpreting and Ethics I
30404	ASL 220	Deaf Culture

### ANATOMY AND PHYSIOLOGY

20031	A&P 120	Introduction to Human Anatomy and Physiology
20032	A&P 120	Introduction to Human Anatomy and Physiology
20033	A&P 120	Introduction to Human Anatomy and Physiology
20034	A&P 120	Introduction to Human Anatomy and Physiology
20610	A&P 120	Introduction to Human Anatomy and Physiology
20611	A&P 120	Introduction to Human Anatomy and Physiology
20612	A&P 120	Introduction to Human Anatomy and Physiology
20036	A&P 150	Introduction to Human Anatomy
20037	A&P 150	Introduction to Human Anatomy
20038	A&P 150	Introduction to Human Anatomy
29452	A&P 150	Introduction to Human Anatomy
24290	A&P 150	Introduction to Human Anatomy
24291	A&P 150	Introduction to Human Anatomy
28982	A&P 150	Introduction to Human Anatomy
29453	A&P 150	Introduction to Human Anatomy
29454	A&P 150	Introduction to Human Anatomy
21221	A&P 151	Introduction to Human Physiology

### ADMINISTRATION OF JUSTICE

20043	AJ 101	Introduction to Administration of Justice
20044	AJ 101	Introduction to Administration of Justice
20045	AJ 101	Introduction to Administration of Justice
25988	AJ 101	Introduction to Administration of Justice
20046	AJ 102	Concepts of Criminal Law
20619	AJ 102	Concepts of Criminal Law
20048	AJ 103	Criminal Procedures
29091	AJ 103	Criminal Procedures
20050	AJ 104	Criminal Evidence
27979	AJ 105	Community Relations and Cultural Awareness
23767	AJ 107	Introduction to Corrections, Probation and Parole
30016	AJ 107	Introduction to Corrections, Probation and Parole
21680	AJ 110	Patrol Procedures and Enforcement Tactics
30492	AJ 110	Patrol Procedures and Enforcement Tactics
30014	AJ 113	Report Writing Procedures
30015	AJ 113	Report Writing Procedures
25506	AJ 202	Substantive Law
25507	AJ 202	Substantive Law
27148	AJ 208	Special Issues in Law Enforcement
20051	AJ 220	Criminal Investigation
20622	AJ 220	Criminal Investigation
20052	AJ 222	Juvenile Procedures

### ANTHROPOLOGY

22380	ANTH 100	Cultural Anthropology
30017	ANTH 100	Cultural Anthropology
21365	ANTH 100	Cultural Anthropology
22879	ANTH 110	Introduction to Forensic Anthropology
22880	ANTH 110	Introduction to Forensic Anthropology
20058	ANTH 115	Physical Anthropology
21260	ANTH 115	Physical Anthropology
30372	ANTH 115	Physical Anthropology
21332	ANTH 115	Physical Anthropology
26734	ANTH 115	Physical Anthropology
23870	ANTH 115	Physical Anthropology
21689	ANTH 115L	Introduction to Physical Anthropology Lab
22284	ANTH 115L	Introduction to Physical Anthropology Lab
29728	ANTH 115L	Introduction to Physical Anthropology Lab
22575	ANTH 170	Introduction to Language and Culture

### AMERICAN SIGN LANGUAGE

24568	ASL 110	American Sign Language I
24569	ASL 110	American Sign Language I
24570	ASL 110	American Sign Language I
24571	ASL 110	American Sign Language I
24573	ASL 110	American Sign Language I
24574	ASL 110	American Sign Language I
24575	ASL 110	American Sign Language I
24576	ASL 110	American Sign Language I
24577	ASL 110	American Sign Language I

### ARCHITECTURE

28944	ARCH 110	Introduction to Architecture and Environmental Design
26129	ARCH 111	Architectural Drafting and Design I
26130	ARCH 111	Architectural Drafting and Design I
20062	ARCH 112	History of Architecture
20625	ARCH 112	History of Architecture
26809	ARCH 112	History of Architecture
29985	ARCH 112	History of Architecture
30347	ARCH 121	Architectural Drafting and Design II
30348	ARCH 121	Architectural Drafting and Design II
29986	ARCH 122	Architectural Delineation
29987	ARCH 122	Architectural Delineation
29988	ARCH 123	Introduction to 2D Computer Aided Drafting
29989	ARCH 123	Introduction to 2D Computer Aided Drafting
22739	ARCH 212	Architectural Design Theory I
22740	ARCH 212	Architectural Design Theory I

# DISTANCE EDUCATION COURSES (CONTINUED)

## ART AND DESIGN

22533	ART 100	Introduction to World Art
20063	ART 100	Introduction to World Art
28217	ART 100	Introduction to World Art
22102	ART 101	Art History I: Prehistory to Gothic
22534	ART 101	Art History I: Prehistory to Gothic
26174	ART 102	Art History II: Renaissance to Rococo
26175	ART 103	Art History III: Neoclassical to Present
30046	ART 104	African Art History
27402	ART 105A	The Arts of Latin America and the Caribbean: Pre-Columbian
30578	ART 108	Black Images in Popular Culture
28018	ART 110	Freehand Drawing
28019	ART 110	Freehand Drawing
21858	ART 114	Storyboarding and Animation Principles for Film
21859	ART 114	Storyboarding and Animation Principles for Film
30636	ART 114	Storyboarding and Animation Principles for Film
30637	ART 114	Storyboarding and Animation Principles for Film
29720	ART 118	History of Women in Visual Arts
24357	ART 150	Introduction to Ceramics
24358	ART 150	Introduction to Ceramics
23419	ART 150	Introduction to Ceramics
23420	ART 150	Introduction to Ceramics
20076	ART 150	Introduction to Ceramics
20975	ART 150	Introduction to Ceramics
20633	ART 150	Introduction to Ceramics
21125	ART 150	Introduction to Ceramics
20078	ART 182A	Lettering and Typography
20977	ART 182A	Lettering and Typography
22426	ART 186	Computer Graphics with Adobe Illustrator
22427	ART 186	Computer Graphics with Adobe Illustrator
27241	ART 186	Computer Graphics with Adobe Illustrator
27242	ART 186	Computer Graphics with Adobe Illustrator
22107	ART 188	Design for Digital Publishing
22108	ART 188	Design for Digital Publishing
20082	ART 192	Photoshop/Digital Imaging
20981	ART 192	Photoshop/Digital Imaging
20083	ART 192	Photoshop/Digital Imaging
20982	ART 192	Photoshop/Digital Imaging
26180	ART 192	Photoshop/Digital Imaging
26181	ART 192	Photoshop/Digital Imaging
27032	ART 192	Photoshop/Digital Imaging
27033	ART 192	Photoshop/Digital Imaging
30582	ART 193	Motion Picture Editing
30583	ART 193	Motion Picture Editing
30584	ART 194A	Advanced Final Cut Pro
30585	ART 194A	Advanced Final Cut Pro
26840	ART 195	3D Modeling for Animation
26841	ART 195	3D Modeling for Animation
20085	ART 196	Web Design with Flash and Dreamweaver
20984	ART 196	Web Design with Flash and Dreamweaver
29079	ART 207	Women and Media

## ASTRONOMY

30325	ASTR 102	Introductory Astronomy: Stars and the Universe
22659	ASTR 102	Introductory Astronomy: Stars and the Universe
22258	ASTR 102	Introductory Astronomy: Stars and the Universe
25395	ASTR 102	Introductory Astronomy: Stars and the Universe
26924	ASTR 102	Introductory Astronomy: Stars and the Universe
28986	ASTR 102	Introductory Astronomy: Stars and the Universe
22796	ASTR 103	Introductory Astronomy: The Solar System
20088	ASTR 103	Introductory Astronomy: The Solar System
21253	ASTR 103	Introductory Astronomy: The Solar System
21254	ASTR 103	Introductory Astronomy: The Solar System
22394	ASTR 103	Introductory Astronomy: The Solar System
21452	ASTR 103	Introductory Astronomy: The Solar System
20640	ASTR 104	Life in the Universe

## AUTOMOTIVE COLLISION REPAIR & REFINISHING/AUTOBODY

29979	AB 51	Non-Structural Repair
25682	AB 51	Non-Structural Repair
30343	AB 52	Structural Damage Repair
27580	AB 53	Steering, Suspension and Powertrain Damage
29255	AB 56	Non-Structural Automotive Welding
30600	AB 63	Production Refinishing
28932	AB 66	Lettering, Striping and Design
28934	AB 67	Automotive Custom Painting
28936	AB 80	Autobody Customer Service
28941	AB 86	Production Management
29983	AB 181	Non-Structural Damage Estimating
29984	AB 181	Non-Structural Damage Estimating
29981	AB 286	Computerized Shop Management
29982	AB 286	Computerized Shop Management

## AUTOMOTIVE MECHANICAL REPAIR TECHNOLOGY

29443	AUTO 54	Introduction to Electric Vehicle
30607	AUTO 73	Automotive Mechanical Repair Occupational Work Experience
20888	AUTO 73	Automotive Mechanical Repair Occupational Work Experience
20889	AUTO 73	Automotive Mechanical Repair Occupational Work Experience
20942	AUTO 73	Automotive Mechanical Repair Occupational Work Experience
28947	AUTO 73	Automotive Mechanical Repair Occupational Work Experience
29444	AUTO 80	Bureau of Automotive Repair (BAR) ASE Alternative Courses for Advanced Emissions Special
29445	AUTO 80	Bureau of Automotive Repair (BAR) ASE Alternative Courses for Advanced Emissions Special
27035	AUTO 100	Automotive Maintenance and Operation
20091	AUTO 100	Automotive Maintenance and Operation
30603	AUTO 100	Automotive Maintenance and Operation
23765	AUTO 100	Automotive Maintenance and Operation
21219	AUTO 100	Automotive Maintenance and Operation
21220	AUTO 100	Automotive Maintenance and Operation
21217	AUTO 110	Automotive Engines
29994	AUTO 110	Automotive Engines
21398	AUTO 121	Drivetrain Transmissions and Axles
21399	AUTO 121	Drivetrain Transmissions and Axles
20645	AUTO 130	Manual Drivetrain and Axles
21134	AUTO 130	Manual Drivetrain and Axles
27207	AUTO 140	Automotive Steering and Suspension
20092	AUTO 150	Automotive Brakes
20644	AUTO 160	Introduction to Automotive Electrical
21133	AUTO 160	Introduction to Automotive Electrical
20899	AUTO 161	Automotive Electricity
21196	AUTO 161	Automotive Electricity
21292	AUTO 161	Automotive Electricity
21293	AUTO 161	Automotive Electricity
30624	AUTO 181	Electronic Engine Management Systems-Corporate
27603	AUTO 181	Electronic Engine Management Systems-Corporate
27604	AUTO 181	Electronic Engine Management Systems-Corporate

## BIOLOGY

23980	BIOL 105	Humans and the Environment
28984	BIOL 105	Humans and the Environment
27648	BIOL 120	Introduction to Biological Science
20103	BIOL 120	Introduction to Biological Science
20107	BIOL 120	Introduction to Biological Science
20106	BIOL 120	Introduction to Biological Science
20110	BIOL 120	Introduction to Biological Science
20653	BIOL 120	Introduction to Biological Science
20654	BIOL 120	Introduction to Biological Science



# DISTANCE EDUCATION COURSES (CONTINUED)

20657 BIOL 120 Introduction to Biological Science  
20114 BIOL 120 Introduction to Biological Science

## BUSINESS ADMINISTRATION

20093 BA 100 Fundamentals of Business  
20094 BA 100 Fundamentals of Business  
20095 BA 100 Fundamentals of Business  
21250 BA 100 Fundamentals of Business  
21438 BA 100 Fundamentals of Business  
21734 BA 100 Fundamentals of Business  
24409 BA 100 Fundamentals of Business  
30374 BA 100 Fundamentals of Business  
26054 BA 100 Fundamentals of Business  
21772 BA 100 Fundamentals of Business  
27445 BA 100 Fundamentals of Business  
26210 BA 100 Fundamentals of Business  
20646 BA 100 Fundamentals of Business  
25586 BA 100 Fundamentals of Business  
26211 BA 100 Fundamentals of Business  
29847 BA 100 Fundamentals of Business  
27419 BA 101 International Business  
22849 BA 101 International Business  
29848 BA 101 International Business  
25354 BA 101 International Business  
26992 BA 104 Managing Cultural Diversity  
21790 BA 104 Managing Cultural Diversity  
26993 BA 104 Managing Cultural Diversity  
29094 BA 106 Human Resource Management  
24099 BA 106 Human Resource Management  
26997 BA 106 Human Resource Management  
26047 BA 106 Human Resource Management  
22123 BA 106 Human Resource Management  
27142 BA 106 Human Resource Management  
23569 BA 106 Human Resource Management  
26781 BA 106 Human Resource Management  
25588 BA 107 Human Relations in Business  
23770 BA 107 Human Relations in Business  
23571 BA 107 Human Relations in Business  
23570 BA 107 Human Relations in Business  
29447 BA 107 Human Relations in Business  
24420 BA 107 Human Relations in Business  
27420 BA 107 Human Relations in Business  
26086 BA 107 Human Relations in Business  
28769 BA 107 Human Relations in Business  
27766 BA 108 Labor Management Relations  
28277 BA 109 Human Resource Development  
27767 BA 109 Human Resource Development  
29849 BA 109 Human Resource Development  
27421 BA 110 Advertising  
29729 BA 110 Advertising  
20649 BA 113 Legal Environment of Business  
21439 BA 113 Legal Environment of Business  
21773 BA 113 Legal Environment of Business  
25589 BA 113 Legal Environment of Business  
26212 BA 113 Legal Environment of Business  
25664 BA 113 Legal Environment of Business  
22851 BA 113 Legal Environment of Business  
27422 BA 113 Legal Environment of Business  
29850 BA 113 Legal Environment of Business  
20098 BA 114 Marketing  
27447 BA 114 Marketing  
22854 BA 114 Marketing  
20650 BA 114 Marketing  
22124 BA 114 Marketing  
26050 BA 114 Marketing  
27761 BA 114 Marketing  
21441 BA 115 Management-Business  
20651 BA 115 Management-Business  
27426 BA 115 Management-Business  
24985 BA 115 Management-Business  
23573 BA 115 Management-Business  
22063 BA 115 Management-Business  
23574 BA 115 Management-Business  
24421 BA 115 Management-Business  
27448 BA 115 Management-Business

22852 BA 118 Retail Management  
24412 BA 118 Retail Management  
26215 BA 118 Retail Management  
27762 BA 118 Retail Management  
29095 BA 118 Retail Management  
29096 BA 118 Retail Management  
22551 BA 120 Management-Accounting and Internal Control  
25590 BA 120 Management-Accounting and Internal Control  
26216 BA 120 Management-Accounting and Internal Control  
26218 BA 120 Management-Accounting and Internal Control  
27763 BA 120 Management-Accounting and Internal Control  
20099 BA 121 Sales  
28285 BA 121 Sales  
30019 BA 126 E-learning  
27760 BA 132 Computer Applications for Managers  
26545 BA 132 Computer Applications for Managers  
22554 BA 132 Computer Applications for Managers  
22553 BA 132 Computer Applications for Managers  
25158 BA 132 Computer Applications for Managers  
27764 BA 132 Computer Applications for Managers  
27765 BA 132 Computer Applications for Managers  
29448 BA 132 Computer Applications for Managers  
29851 BA 132 Computer Applications for Managers  
27285 BA 152 Fundamentals of Importing and Exporting  
21774 BA 153 Introduction to Entrepreneurship  
27427 BA 153 Introduction to Entrepreneurship  
26055 BA 155 Introduction to Global Logistics  
30020 BA 156 Motivational Presentation Skills for Managers  
25592 BA 156 Motivational Presentation Skills for Managers  
22287 BA 156 Motivational Presentation Skills for Managers  
23771 BA 156 Motivational Presentation Skills for Managers  
26737 BA 156 Motivational Presentation Skills for Managers  
27145 BA 156 Motivational Presentation Skills for Managers  
29097 BA 156 Motivational Presentation Skills for Managers  
22661 BA 157 Principles of Public Relations  
23585 BA 204 Project Management  
23586 BA 205 Organizational Leadership  
29730 BA 205 Organizational Leadership  
22549 BA 208 Leadership for Women in Business  
25738 BA 208 Leadership for Women in Business  
26221 BA 208 Leadership for Women in Business

## BUSINESS COMMUNICATIONS OFFICE TECHNOLOGY

22856 BCOT 60 Customer Service/Telephone Techniques  
21346 BCOT 62 Computer Keyboarding  
21347 BCOT 62 Computer Keyboarding  
21488 BCOT 63 Keyboarding Speed/Control Building  
21489 BCOT 63 Keyboarding Speed/Control Building  
27728 BCOT 63 Keyboarding Speed/Control Building  
27729 BCOT 63 Keyboarding Speed/Control Building  
29274 BCOT 81 Legal Office Procedures  
29413 BCOT 81 Legal Office Procedures  
29114 BCOT 96 Microsoft PowerPoint  
29115 BCOT 96 Microsoft PowerPoint  
21350 BCOT 97 Microsoft Outlook  
21351 BCOT 97 Microsoft Outlook  
21357 BCOT 112 Microsoft Word  
21358 BCOT 112 Microsoft Word  
25596 BCOT 113 Microsoft Excel  
25597 BCOT 113 Microsoft Excel  
21359 BCOT 113 Microsoft Excel  
21360 BCOT 113 Microsoft Excel  
29116 BCOT 114 Introduction to Microsoft Office  
29117 BCOT 114 Introduction to Microsoft Office  
30495 BCOT 118 Microsoft Access for Office Technology  
30496 BCOT 118 Microsoft Access for Office Technology  
29684 BCOT 148 Effective Business Presentations  
26202 BCOT 162 Business Spelling and Proofreading Skills  
25410 BCOT 247 Managerial Business Communications  
25668 BCOT 247 Managerial Business Communications

# DISTANCE EDUCATION COURSES (CONTINUED)

## CHEMISTRY

20002	CHEM 100	Introductory Chemistry
20003	CHEM 100	Introductory Chemistry
20004	CHEM 100	Introductory Chemistry
30201	CHEM 100	Introductory Chemistry
30632	CHEM 100	Introductory Chemistry
24299	CHEM 100	Introductory Chemistry
29356	CHEM 100	Introductory Chemistry
30633	CHEM 100	Introductory Chemistry
25399	CHEM 100	Introductory Chemistry
29355	CHEM 100	Introductory Chemistry
24296	CHEM 100	Introductory Chemistry
25400	CHEM 100	Introductory Chemistry
24297	CHEM 100	Introductory Chemistry
24298	CHEM 100	Introductory Chemistry
20023	CHEM 211	Organic Chemistry
25406	CHEM 211	Organic Chemistry
26196	CHEM 212	Organic Chemistry

## CHILD DEVELOPMENT

20120	CD 110	Child Development
20121	CD 110	Child Development
23800	CD 110	Child Development
20122	CD 110	Child Development
22181	CD 110	Child Development
23805	CD 110	Child Development
20124	CD 110	Child Development
22182	CD 110	Child Development
30055	CD 110	Child Development
27025	CD 110	Child Development
27026	CD 110	Child Development
20661	CD 124	Teaching in a Diverse Society
22183	CD 124	Teaching in a Diverse Society
20125	CD 139	Observation, Assessment, and Positive Guidance of Childhood Behavior
21761	CD 139	Observation, Assessment, and Positive Guidance of Childhood Behavior
29279	CD 139	Observation, Assessment, and Positive Guidance of Childhood Behavior

## CHILD DEVELOPMENT/EARLY CHILDHOOD

20128	CDEC 111	Principles and Practices in Early Childhood Education
20127	CDEC 111	Principles and Practices in Early Childhood Education
24178	CDEC 111	Principles and Practices in Early Childhood Education
20665	CDEC 112	Introduction to Curriculum
20130	CDEC 112	Introduction to Curriculum
23803	CDEC 112	Introduction to Curriculum
23804	CDEC 113	The Child, Family, and Community
20132	CDEC 113	The Child, Family, and Community
21660	CDEC 113	The Child, Family, and Community
20662	CDEC 161	Health, Safety, and Nutrition
22355	CDEC 161	Health, Safety, and Nutrition
26168	CDEC 166	Administration I: Programs in Early Childhood Education
20668	CDEC 230	Adult Supervision and Mentoring in Early Care and Education

## CHILD DEVELOPMENT/INFANT TODDLER

20669	CDIT 151	Infant and Toddler Development
22833	CDIT 152	Care and Education for Infants and Toddlers

## CHILD DEVELOPMENT/SPECIAL EDUCATION

26166	CDSE 150	Introduction to Children with Special Needs
26167	CDSE 152	Curriculum and Strategies for Children with Special Needs

## COMMUNICATION STUDIES

29593	COMM 60	Basics of Speech Communication
26984	COMM 100	Introduction to Communications Studies
20574	COMM 100	Introduction to Communications Studies
20575	COMM 100	Introduction to Communications Studies
20578	COMM 100	Introduction to Communications Studies
20579	COMM 100	Introduction to Communications Studies
20580	COMM 100	Introduction to Communications Studies
21656	COMM 100	Introduction to Communications Studies
22279	COMM 100	Introduction to Communications Studies
25973	COMM 100	Introduction to Communications Studies
26507	COMM 100	Introduction to Communications Studies
27439	COMM 100	Introduction to Communications Studies
27451	COMM 100	Introduction to Communications Studies
27469	COMM 100	Introduction to Communications Studies
27917	COMM 100	Introduction to Communications Studies
29246	COMM 100	Introduction to Communications Studies
29352	COMM 100	Introduction to Communications Studies
29632	COMM 100	Introduction to Communications Studies
29633	COMM 100	Introduction to Communications Studies
29243	COMM 100	Introduction to Communications Studies
30190	COMM 100	Introduction to Communications Studies
30191	COMM 100	Introduction to Communications Studies
27468	COMM 100	Introduction to Communications Studies
29244	COMM 100	Introduction to Communications Studies
30696	COMM 100	Introduction to Communications Studies
30697	COMM 100	Introduction to Communications Studies
30698	COMM 100	Introduction to Communications Studies
20887	COMM 100	Introduction to Communications Studies
29245	COMM 100	Introduction to Communications Studies
30189	COMM 100	Introduction to Communications Studies
24079	COMM 100	Introduction to Communications Studies
21658	COMM 103	Argumentation, Persuasion, and Critical Thinking
26988	COMM 103	Argumentation, Persuasion, and Critical Thinking
24624	COMM 103	Argumentation, Persuasion, and Critical Thinking
25632	COMM 110	Intercultural Communication
25633	COMM 110	Intercultural Communication
29249	COMM 115	Gender, Communication, and the Digital Revolution
28151	COMM 115	Gender, Communication, and the Digital Revolution
20582	COMM 120	Interpersonal Communication
20583	COMM 120	Interpersonal Communication
30193	COMM 120	Interpersonal Communication
25059	COMM 120	Interpersonal Communication
27083	COMM 120	Interpersonal Communication
29251	COMM 120	Interpersonal Communication
23507	COMM 125	Organizational Communication
27919	COMM 125	Organizational Communication
21866	COMM 130	Public Speaking
20586	COMM 130	Public Speaking
21463	COMM 130	Public Speaking
23938	COMM 130	Public Speaking
23937	COMM 130	Public Speaking
25976	COMM 130	Public Speaking
22411	COMM 130	Public Speaking
28407	COMM 130	Public Speaking
29252	COMM 130	Public Speaking
24619	COMM 130	Public Speaking
30194	COMM 130	Public Speaking
29254	COMM 130	Public Speaking
21657	COMM 132	Small Group Communication
26315	COMM 132	Small Group Communication
24622	COMM 140	Oral Interpretation of Literature
30195	COMM 145	Storytelling
24623	COMM 200	Contemporary Communication Topics
27190	COMM 231	Forensics Activity 1 (Competitive Speech and Debate)
27191	COMM 232	Forensics Activity 2 (Competitive Speech and Debate)

# DISTANCE EDUCATION COURSES (CONTINUED)

## COMPUTER AND INFORMATION SCIENCES

27672	CIS 58A	PC Operating System A+ Certification
27673	CIS 58A	PC Operating System A+ Certification
29361	CIS 58B	PC Core Hardware A+ Certification
29362	CIS 58B	PC Core Hardware A+ Certification
20138	CIS 101	Introduction to Computer Information Systems
20993	CIS 101	Introduction to Computer Information Systems
20141	CIS 101	Introduction to Computer Information Systems
20994	CIS 101	Introduction to Computer Information Systems
20145	CIS 101	Introduction to Computer Information Systems
20995	CIS 101	Introduction to Computer Information Systems
26877	CIS 101	Introduction to Computer Information Systems
26878	CIS 101	Introduction to Computer Information Systems
23987	CIS 101	Introduction to Computer Information Systems
23988	CIS 101	Introduction to Computer Information Systems
20673	CIS 101	Introduction to Computer Information Systems
21139	CIS 101	Introduction to Computer Information Systems
29800	CIS 101	Introduction to Computer Information Systems
29801	CIS 101	Introduction to Computer Information Systems
20674	CIS 102	Introduction to Microcomputer Hardware and Applications Software
21140	CIS 102	Introduction to Microcomputer Hardware and Applications Software
24104	CIS 103	Computer Programming Logic
24105	CIS 103	Computer Programming Logic
20147	CIS 103	Computer Programming Logic
20998	CIS 103	Computer Programming Logic
20676	CIS 103	Computer Programming Logic
21142	CIS 103	Computer Programming Logic
27962	CIS 103	Computer Programming Logic
27963	CIS 103	Computer Programming Logic
25183	CIS 103	Computer Programming Logic
25184	CIS 103	Computer Programming Logic
28997	CIS 151	Microsoft Excel for Information Systems/Information Technology
28998	CIS 151	Microsoft Excel for Information Systems/Information Technology
26885	CIS 155	Microsoft Access
26886	CIS 155	Microsoft Access
26889	CIS 160	Web Page Development
26890	CIS 160	Web Page Development
24321	CIS 162	HTML and CSS
24322	CIS 162	HTML and CSS
24307	CIS 170A	Networking Fundamentals
24308	CIS 170A	Networking Fundamentals
24311	CIS 170B	Network + Certification
24312	CIS 170B	Network + Certification
24313	CIS 170E	Router Configurations and Protocol
24314	CIS 170E	Router Configurations and Protocol
24315	CIS 170F	Advanced Switching and Routing
24316	CIS 170F	Advanced Switching and Routing
24317	CIS 170G	Wide Area Networks
24318	CIS 170G	Wide Area Networks
26367	CIS 170H	TCP/IP Fundamentals
29001	CIS 170I	Cisco Network Security
29002	CIS 170I	Cisco Network Security
24305	CIS 170L	Cybersecurity Fundamentals
24306	CIS 170L	Cybersecurity Fundamentals
30630	CIS 171A	Introduction to Cloud Computing
30631	CIS 171A	Introduction to Cloud Computing
21448	CIS 180	Programming in C/C++
21449	CIS 180	Programming in C/C++
29712	CIS 180	Programming in C/C++
29713	CIS 180	Programming in C/C++
25716	CIS 183	Java Programming
25717	CIS 183	Java Programming
25718	CIS 183	Java Programming
25719	CIS 183	Java Programming
26365	CIS 185	Discrete Structures
26366	CIS 185	Discrete Structures
28282	CIS 212	Introduction to Microsoft Windows Administration
28283	CIS 212	Introduction to Microsoft Windows Administration
28737	CIS 213F	Microsoft Windows Server Administration
28738	CIS 213F	Microsoft Windows Server Administration
20679	CIS 214	Unix and Linux Operating Systems
21145	CIS 214	Unix and Linux Operating Systems
30202	CIS 231	Computer Organization and Assembly Language Programming

30203	CIS 231	Computer Organization and Assembly Language Programming
29003	CIS 280X	Object-Oriented Programming in C++
29004	CIS 280X	Object-Oriented Programming in C++
24331	CIS 288	Mobile Application Development
24332	CIS 288	Mobile Application Development
27686	CIS 292	Data Structures
29717	CIS 292	Data Structures

## COSMETOLOGY

30004	COS 99	Directed Studies
-------	--------	------------------

## COUNSELING

30531	COUN 101B	Educational Planning
30532	COUN 101B	Educational Planning
30533	COUN 101B	Educational Planning
23685	COUN 101B	Educational Planning
30313	COUN 101B	Educational Planning
23687	COUN 101B	Educational Planning
29419	COUN 101C	Navigating the Transfer Process
25033	COUN 200	Success in College and Career
25032	COUN 200	Success in College and Career
26347	COUN 200	Success in College and Career
30043	COUN 200	Success in College and Career
30044	COUN 200	Success in College and Career
30310	COUN 200	Success in College and Career
29585	COUN 200	Success in College and Career
20133	COUN 200	Success in College and Career
22306	COUN 200	Success in College and Career
30306	COUN 200	Success in College and Career
30307	COUN 200	Success in College and Career

## CULINARY ARTS

30536	CA 55	Fundamentals of Responsible Alcohol Service
25517	CA 55	Fundamentals of Responsible Alcohol Service
24705	CA 120	Introduction to the Hospitality Industry
30538	CA 240	Human Relations in Hospitality
24193	CA 260	Foods Purchase and Control

## DANCE

21800	DANC 100	Dance Appreciation
27084	DANC 100	Dance Appreciation
29898	DANC 100	Dance Appreciation
29825	DANC 100	Dance Appreciation
22679	DANC 100	Dance Appreciation
27555	DANC 100	Dance Appreciation
28158	DANC 100	Dance Appreciation
28735	DANC 100	Dance Appreciation
22083	DANC 100	Dance Appreciation
26742	DANC 100	Dance Appreciation
28682	DANC 100	Dance Appreciation
28924	DANC 100	Dance Appreciation
29824	DANC 100	Dance Appreciation
27703	DANC 101	History of Dance
30220	DANC 101	History of Dance
21802	DANC 105	Introduction to Dance Movement

## DENTAL ASSISTING

20155	DA 53	Introduction to Chairside Assisting
20159	DA 54	Introduction to Operatory Procedures
30540	DA 75	Clinical II Cooperative Office Training
30541	DA 75	Clinical II Cooperative Office Training

# DISTANCE EDUCATION COURSES (CONTINUED)

## EARTH SCIENCE

21885	ESCI 104	Oceanography
20697	ESCI 104	Oceanography
27394	ESCI 104	Oceanography
27955	ESCI 104	Oceanography
21886	ESCI 104L	Oceanography Laboratory
29363	ESCI 106	Weather and Climate
20223	ESCI 110	Introduction to Earth Science
21003	ESCI 110	Introduction to Earth Science
23824	ESCI 110	Introduction to Earth Science
23825	ESCI 110	Introduction to Earth Science
20224	ESCI 110	Introduction to Earth Science
21004	ESCI 110	Introduction to Earth Science
21267	ESCI 110	Introduction to Earth Science
21356	ESCI 110	Introduction to Earth Science
27661	ESCI 110	Introduction to Earth Science
27662	ESCI 110	Introduction to Earth Science

## ECONOMICS

22882	ECON 101	Economic Issues and Policy
29118	ECON 102	Women in the Global Economy
21837	ECON 201	Principles of Macroeconomics
21838	ECON 201	Principles of Macroeconomics
24448	ECON 201	Principles of Macroeconomics
24449	ECON 201	Principles of Macroeconomics
26547	ECON 201	Principles of Macroeconomics
26548	ECON 201	Principles of Macroeconomics
27256	ECON 201	Principles of Macroeconomics
27257	ECON 201	Principles of Macroeconomics
27730	ECON 201	Principles of Macroeconomics
27731	ECON 201	Principles of Macroeconomics
29530	ECON 201	Principles of Macroeconomics
29531	ECON 201	Principles of Macroeconomics
24442	ECON 201M	Principles of Macroeconomics
24443	ECON 201M	Principles of Macroeconomics
24444	ECON 201M	Principles of Macroeconomics
24445	ECON 201M	Principles of Macroeconomics
26020	ECON 201M	Principles of Macroeconomics
26021	ECON 201M	Principles of Macroeconomics
27258	ECON 201M	Principles of Macroeconomics
27259	ECON 201M	Principles of Macroeconomics
27732	ECON 201M	Principles of Macroeconomics
27733	ECON 201M	Principles of Macroeconomics
29532	ECON 201M	Principles of Macroeconomics
29533	ECON 201M	Principles of Macroeconomics
23776	ECON 202	Principles of Microeconomics
23777	ECON 202	Principles of Microeconomics
27734	ECON 202	Principles of Microeconomics
27735	ECON 202	Principles of Microeconomics
27149	ECON 202	Principles of Microeconomics
27150	ECON 202	Principles of Microeconomics
30377	ECON 202	Principles of Microeconomics
30378	ECON 202	Principles of Microeconomics
27738	ECON 202	Principles of Microeconomics
27739	ECON 202	Principles of Microeconomics
29534	ECON 202	Principles of Microeconomics
27740	ECON 202M	Principles of Microeconomics
27741	ECON 202M	Principles of Microeconomics
23778	ECON 202M	Principles of Microeconomics
23779	ECON 202M	Principles of Microeconomics
27736	ECON 202M	Principles of Microeconomics
27737	ECON 202M	Principles of Microeconomics
30379	ECON 202M	Principles of Microeconomics
30380	ECON 202M	Principles of Microeconomics
27136	ECON 202M	Principles of Microeconomics
27137	ECON 202M	Principles of Microeconomics
29536	ECON 202M	Principles of Microeconomics
29537	ECON 202M	Principles of Microeconomics

## EDUCATION

21425	EDEL 100	Introduction to Teaching and Learning in Diverse Contemporary Classrooms
29123	EDEL 100	Introduction to Teaching and Learning in Diverse Contemporary Classrooms
29754	EDEL 100	Introduction to Teaching and Learning in Diverse Contemporary Classrooms
25504	EDEL 200	Introduction to the Teaching Profession

## EDUCATIONAL TECHNOLOGY (EDTCH)

29441	EDT 110	Introduction to Educational Technology
29442	EDT 110	Introduction to Educational Technology
22293	EDT 110	Introduction to Educational Technology
22294	EDT 110	Introduction to Educational Technology
24172	EDT 110	Introduction to Educational Technology
24173	EDT 110	Introduction to Educational Technology
21249	EDT 125	Fundamentals of Online Teaching
30023	EDT 132	Using Audio in the Classroom
30024	EDT 135	Slide Presentation Software for Educators
30025	EDT 139	E-Portfolios for Education
30026	EDT 141	Web Design for Educators

## ENGINEERING

28148	ENGR 112	Engineering Graphics
28149	ENGR 112	Engineering Graphics
27060	ENGR 235	Statics

## ENGINEERING DESIGN TECHNOLOGY

24237	ENGT 103	Introduction to Engineering Design Using Inventor
24238	ENGT 103	Introduction to Engineering Design Using Inventor
21468	ENGT 116	Blueprint Reading
21469	ENGT 116	Blueprint Reading
28411	ENGT 116	Blueprint Reading
28412	ENGT 116	Blueprint Reading
26136	ENGT 117	Geometrical Dimensioning and Tolerancing
28039	ENGT 131	Design Fundamentals Including 3D Modeling
28040	ENGT 131	Design Fundamentals Including 3D Modeling
30005	ENGT 139	Cloud based 3D modeling with Onshape
30006	ENGT 139	Cloud based 3D modeling with Onshape
30007	ENGT 258	Tools and Fixtures Applications Using Solid Modeling
30008	ENGT 258	Tools and Fixtures Applications Using Solid Modeling
24245	ENGT 259	Solidworks Introduction
24246	ENGT 259	Solidworks Introduction
28956	ENGT 260	Advanced Modeling Using SolidWorks
28957	ENGT 260	Advanced Modeling Using SolidWorks

## ENGINEERING TECHNOLOGY

22684	ET 101	Principles of Engineering Technology
22685	ET 101	Principles of Engineering Technology

## ENGLISH

20185	ENGL 100	Freshman Composition
20191	ENGL 100	Freshman Composition
20192	ENGL 100	Freshman Composition
20194	ENGL 100	Freshman Composition
20196	ENGL 100	Freshman Composition
30157	ENGL 100	Freshman Composition



## DISTANCE EDUCATION COURSES (CONTINUED)

24543	ENGL 102	Introduction to Literature
24544	ENGL 102	Introduction to Literature
27770	ENGL 102	Introduction to Literature
29647	ENGL 102	Introduction to Literature
26407	ENGL 103	Critical and Argumentative Writing
20212	ENGL 103	Critical and Argumentative Writing
22347	ENGL 103	Critical and Argumentative Writing
20213	ENGL 103	Critical and Argumentative Writing
22584	ENGL 103	Critical and Argumentative Writing
22585	ENGL 103	Critical and Argumentative Writing
26414	ENGL 103	Critical and Argumentative Writing
20215	ENGL 103	Critical and Argumentative Writing
20216	ENGL 103	Critical and Argumentative Writing
25970	ENGL 103	Critical and Argumentative Writing
20217	ENGL 103	Critical and Argumentative Writing
24545	ENGL 103	Critical and Argumentative Writing
21235	ENGL 103	Critical and Argumentative Writing
21237	ENGL 103	Critical and Argumentative Writing
22066	ENGL 103	Critical and Argumentative Writing
24547	ENGL 103	Critical and Argumentative Writing
30156	ENGL 103	Critical and Argumentative Writing
26409	ENGL 103	Critical and Argumentative Writing
27771	ENGL 103	Critical and Argumentative Writing
27251	ENGL 103	Critical and Argumentative Writing
21605	ENGL 103	Critical and Argumentative Writing
27304	ENGL 103	Critical and Argumentative Writing
30399	ENGL 103	Critical and Argumentative Writing
24546	ENGL 103	Critical and Argumentative Writing
26408	ENGL 103	Critical and Argumentative Writing
26413	ENGL 103	Critical and Argumentative Writing
21474	ENGL 103	Critical and Argumentative Writing
21476	ENGL 103	Critical and Argumentative Writing
25480	ENGL 107	Vocabulary Building
29212	ENGL 110	Critical Thinking Through Literature
29214	ENGL 110	Critical Thinking Through Literature
30166	ENGL 110	Critical Thinking Through Literature
30165	ENGL 110	Critical Thinking Through Literature
26293	ENGL 222	Children's Literature
27773	ENGL 225	Mexican Literature in Translation
25481	ENGL 228	Shakespeare's Plays
30167	ENGL 231	Literature and Film
26963	ENGL 234	Readings in Short Fiction
30169	ENGL 237	Asian American Literature
20692	ENGL 241	Screenwriting
30168	ENGL 244	Writing Short Fiction
20221	ENGL 246A	Survey of British Literature A: Anglo-Saxon to 18th Century
20694	ENGL 248A	Masterpieces of World Literature

### ENGLISH AS A SECOND LANGUAGE

29623	ESL 5	ESL Grammar, Reading, and Writing 5
30535	ESL 5	ESL Grammar, Reading, and Writing 5
30650	ESL 10	ESL Speaking and Listening 1
25626	ESL 11	ESL Reading 1
23479	ESL 14	Pronunciation Plus
30651	ESL 20	ESL Speaking and Listening 2
30171	ESL 21A	ESL Intermediate Vocabulary
25629	ESL 31	ESL Reading 2
23699	ESL 120	Preparation for College Writing for Non-Native English Speakers
23700	ESL 120	Preparation for College Writing for Non-Native English Speakers
27913	ESL 152	Introduction to College Composition for Non-Native English Speakers
27914	ESL 152	Introduction to College Composition for Non-Native English Speakers

### FILM

21843	FILM 101	Motion Picture Production
21844	FILM 101	Motion Picture Production
28218	FILM 101	Motion Picture Production
28219	FILM 101	Motion Picture Production
29423	FILM 101	Motion Picture Production
29424	FILM 101	Motion Picture Production

30316	FILM 102	Television Production
30317	FILM 102	Television Production
28238	FILM 102	Television Production
28239	FILM 102	Television Production
30318	FILM 103	Television Commercial and Public Service Announcement Production
30319	FILM 103	Television Commercial and Public Service Announcement Production
30320	FILM 103	Television Commercial and Public Service Announcement Production
30321	FILM 103	Television Commercial and Public Service Announcement Production
29429	FILM 104	Motion Picture and Digital Cinematography
29430	FILM 104	Motion Picture and Digital Cinematography
30048	FILM 104	Motion Picture and Digital Cinematography
30049	FILM 104	Motion Picture and Digital Cinematography
23435	FILM 241	Screenwriting
29431	FILM 294	Advanced Motion Picture Production
29432	FILM 294	Advanced Motion Picture Production

### FINANCE

21957	FIN 125	Personal Finance
29587	FIN 125M	Personal Finance
29588	FIN 125M	Personal Finance
30370	FIN 125M	Personal Finance
30013	FIN 125M	Personal Finance
30371	FIN 125M	Personal Finance

### GEOGRAPHY

22791	GEOG 101	Physical Geography
29010	GEOG 101	Physical Geography
20239	GEOG 101	Physical Geography
20241	GEOG 101	Physical Geography
26913	GEOG 101	Physical Geography
23823	GEOG 101	Physical Geography
23998	GEOG 101	Physical Geography
29005	GEOG 101	Physical Geography
27055	GEOG 101	Physical Geography
21466	GEOG 101L	Physical Geography Laboratory
21467	GEOG 101L	Physical Geography Laboratory
27056	GEOG 101L	Physical Geography Laboratory
20242	GEOG 102	Cultural Geography
23821	GEOG 102	Cultural Geography
27659	GEOG 103	Environmental Geography
23822	GEOG 105	World Regional Geography
26914	GEOG 105	World Regional Geography
27658	GEOG 105	World Regional Geography

### GEOLOGY

20703	GEOG 101	Physical Geology
21157	GEOG 101	Physical Geology
21888	GEOG 101	Physical Geology
21889	GEOG 101	Physical Geology
27057	GEOG 101	Physical Geology
27058	GEOG 101	Physical Geology
29011	GEOG 102	Physical Geology Lecture
29007	GEOG 102L	Physical Geology Laboratory
29008	GEOG 103	Environmental Geology Lecture
30673	GEOG 208	The Age of the Dinosaurs

### GERMAN

30405	GERM 102	Elementary German
30406	GERM 102	Elementary German

# DISTANCE EDUCATION COURSES (CONTINUED)

## HEALTH EDUCATION

20246	HED 100	Contemporary Health Problems
20856	HED 100	Contemporary Health Problems
20248	HED 100	Contemporary Health Problems
20249	HED 100	Contemporary Health Problems
20250	HED 100	Contemporary Health Problems
20251	HED 100	Contemporary Health Problems
20254	HED 100	Contemporary Health Problems
20709	HED 100	Contemporary Health Problems
21627	HED 100	Contemporary Health Problems
21629	HED 100	Contemporary Health Problems
29659	HED 100	Contemporary Health Problems
21316	HED 100	Contemporary Health Problems
24493	HED 100	Contemporary Health Problems
20257	HED 100	Contemporary Health Problems
25072	HED 100	Contemporary Health Problems
20901	HED 100	Contemporary Health Problems
21314	HED 100	Contemporary Health Problems
27579	HED 100	Contemporary Health Problems
29617	HED 101	Stress Management
29618	HED 101	Stress Management
29619	HED 101	Stress Management
30258	HED 101	Stress Management
29620	HED 101	Stress Management
30574	HED 101	Stress Management
30575	HED 101	Stress Management
27089	HED 103	Women, Their Bodies and Health
29296	HED 105	Mind, Body, and Health
20259	HED 110	Community First Aid and CPR
21213	HED 110	Community First Aid and CPR
24495	HED 110	Community First Aid and CPR
30259	HED 110	Community First Aid and CPR
29297	HED 202	Health Systems and Perspectives

## HEALTH OCCUPATIONS

20944	HO 53	Electrocardiography
20903	HO 54	Medical Laboratory Skills
20892	HO 55	Phlebotomy Procedures

## HISTORY

21416	HIST 102	Political and Social History of the United States: 1500s to 1876
26223	HIST 102	Political and Social History of the United States: 1500s to 1876
23877	HIST 102	Political and Social History of the United States: 1500s to 1876
25990	HIST 102	Political and Social History of the United States: 1500s to 1876
26222	HIST 102	Political and Social History of the United States: 1500s to 1876
27007	HIST 102	Political and Social History of the United States: 1500s to 1876
27268	HIST 102	Political and Social History of the United States: 1500s to 1876
27269	HIST 102	Political and Social History of the United States: 1500s to 1876
27743	HIST 102	Political and Social History of the United States: 1500s to 1876
22143	HIST 102	Political and Social History of the United States: 1500s to 1876
21418	HIST 103	Political and Social History of the United States: 1877 to Present
21693	HIST 103	Political and Social History of the United States: 1877 to Present
21842	HIST 103	Political and Social History of the United States: 1877 to Present
24022	HIST 103	Political and Social History of the United States: 1877 to Present
27008	HIST 103	Political and Social History of the United States: 1877 to Present

24460	HIST 103	Political and Social History of the United States: 1877 to Present
24461	HIST 103	Political and Social History of the United States: 1877 to Present
24462	HIST 103	Political and Social History of the United States: 1877 to Present
26761	HIST 103	Political and Social History of the United States: 1877 to Present
30382	HIST 103	Political and Social History of the United States: 1877 to Present
21839	HIST 103	Political and Social History of the United States: 1877 to Present
27457	HIST 103	Political and Social History of the United States: 1877 to Present
27272	HIST 110	African/American History
20268	HIST 230	History of Mexico
20712	HIST 230	History of Mexico
20269	HIST 235	History of Latin America
29124	HIST 260	Survey of the History of Asia

## HUMANITIES

30586	HUM 100	The Art of Being Human
28036	HUM 100	The Art of Being Human
30700	HUM 100	The Art of Being Human
23421	HUM 100	The Art of Being Human

## JOURNALISM

20275	JOUR 100	Mass Communications and Society
27034	JOUR 100	Mass Communications and Society
20276	JOUR 101	Beginning Newswriting and Reporting
23548	JOUR 107A	College Newspaper
23549	JOUR 107A	College Newspaper
23550	JOUR 107B	Intermediate College Newspaper
23551	JOUR 107B	Intermediate College Newspaper
23552	JOUR 107C	Intermediate Advanced College Newspaper
23553	JOUR 107C	Intermediate Advanced College Newspaper
23554	JOUR 107D	Advanced College Newspaper
23555	JOUR 107D	Advanced College Newspaper

## KINESIOLOGY

24640	KIN 100	Introduction to Kinesiology
25558	KIN 100	Introduction to Kinesiology
26249	KIN 100	Introduction to Kinesiology
26250	KIN 100	Introduction to Kinesiology
27090	KIN 100	Introduction to Kinesiology
27994	KIN 100	Introduction to Kinesiology
29621	KIN 100	Introduction to Kinesiology
30260	KIN 100	Introduction to Kinesiology
26743	KIN 100	Introduction to Kinesiology
27995	KIN 100	Introduction to Kinesiology
28925	KIN 100	Introduction to Kinesiology
29826	KIN 100	Introduction to Kinesiology
29827	KIN 100	Introduction to Kinesiology
24641	KIN 102	Introduction to Athletic Training
25951	KIN 102	Introduction to Athletic Training
24645	KIN 104	Fitness and Wellness
24646	KIN 104	Fitness and Wellness
24647	KIN 104	Fitness and Wellness
24650	KIN 104	Fitness and Wellness
24652	KIN 104	Fitness and Wellness
30262	KIN 104	Fitness and Wellness
30263	KIN 104	Fitness and Wellness
27287	KIN 108	Women in Sports
27401	KIN 108	Women in Sports
28172	KIN 110	Community First Aid and CPR
28173	KIN 110	Community First Aid and CPR
28174	KIN 110	Community First Aid and CPR
30264	KIN 110	Community First Aid and CPR
28175	KIN 130	Theory of Coaching
24660	KIN 134	Theory of Football

# DISTANCE EDUCATION COURSES (CONTINUED)

24661	KIN 134	Theory of Football
24663	KIN 202	Measurement and Interpretation of Fitness
24664	KIN 202	Measurement and Interpretation of Fitness
28169	KIN 205	Anatomical Movement Analysis
30576	KIN 211	Sport Management
27711	KIN 211	Sport Management
29631	KIN 211	Sport Management
24665	KIN 271A	Occupational Work Experience Athletic Training

## LAW

29721	LAW 101	Introduction to Law
25412	LAW 110	Business Law
27982	LAW 110	Business Law
21984	LAW 111	Business Law
26748	LAW 111	Business Law
22202	LAW 290	Capstone Course-Paralegal Program

## LIBRARY

22163	LIBR 100	Introduction to Library Research
22167	LIBR 100	Introduction to Library Research
22170	LIBR 100	Introduction to Library Research
22171	LIBR 100	Introduction to Library Research

## MACHINE TOOL TECHNOLOGY

21725	MTT 51	MasterCAM Milling
21726	MTT 51	MasterCAM Milling
20756	MTT 52	Setup and Operation of CNC Milling Machines
25533	MTT 56	CNC Shop Inspection
21258	MTT 57	Setup and Operation of CNC Lathes
23600	MTT 68	Computer-Assisted Inspection Using Verisurf
26145	MTT 71	MasterCam Multi-Axis Milling
27620	MTT 72	MasterCAM Multi-Axis Turning
22099	MTT 92L	Mastercam Laboratory
22386	MTT 100	Machine Tool Introduction
25744	MTT 100	Machine Tool Introduction
30610	MTT 110	Industrial Maintenance of Machine Tools
29261	MTT 168	Advanced Computer-Assisted Inspection Using Verisurf
29262	MTT 168	Advanced Computer-Assisted Inspection Using Verisurf

## MATHEMATICS

29017	MATH 5	Mathematics Learning Strategies
29019	MATH 5	Mathematics Learning Strategies
29024	MATH 5	Mathematics Learning Strategies
29028	MATH 5	Mathematics Learning Strategies
29045	MATH 5	Mathematics Learning Strategies
29046	MATH 5	Mathematics Learning Strategies
29047	MATH 5	Mathematics Learning Strategies
29053	MATH 5	Mathematics Learning Strategies
29055	MATH 5	Mathematics Learning Strategies
29056	MATH 5	Mathematics Learning Strategies
29057	MATH 5	Mathematics Learning Strategies
29058	MATH 5	Mathematics Learning Strategies
29059	MATH 5	Mathematics Learning Strategies
29060	MATH 5	Mathematics Learning Strategies
29061	MATH 5	Mathematics Learning Strategies
30699	MATH 5	Mathematics Learning Strategies
30686	MATH 5	Mathematics Learning Strategies
30702	MATH 5	Mathematics Learning Strategies
20282	MATH 40	Prealgebra
20284	MATH 40	Prealgebra
20290	MATH 40	Prealgebra
20721	MATH 40	Prealgebra
20724	MATH 40	Prealgebra
20294	MATH 60	Elementary Algebra
20303	MATH 60	Elementary Algebra
20726	MATH 60	Elementary Algebra

20729	MATH 60	Elementary Algebra
21273	MATH 60	Elementary Algebra
26200	MATH 60	Elementary Algebra
29408	MATH 60	Elementary Algebra
30342	MATH 60	Elementary Algebra
20295	MATH 60	Elementary Algebra
20307	MATH 70	Plane Geometry
20308	MATH 70	Plane Geometry
26920	MATH 75	Mathematical Literacy for College Students
29035	MATH 75	Mathematical Literacy for College Students
20311	MATH 80	Intermediate Algebra
20312	MATH 80	Intermediate Algebra
26923	MATH 80	Intermediate Algebra
20315	MATH 80	Intermediate Algebra
20317	MATH 80	Intermediate Algebra
20318	MATH 80	Intermediate Algebra
20321	MATH 80	Intermediate Algebra
20731	MATH 80	Intermediate Algebra
20733	MATH 80	Intermediate Algebra
22843	MATH 80	Intermediate Algebra
24341	MATH 80	Intermediate Algebra
25052	MATH 80	Intermediate Algebra
27340	MATH 80	Intermediate Algebra
28231	MATH 80	Intermediate Algebra
29366	MATH 80	Intermediate Algebra
30341	MATH 80	Intermediate Algebra
29716	MATH 80	Intermediate Algebra
29736	MATH 80	Intermediate Algebra
29364	MATH 80	Intermediate Algebra
20316	MATH 80	Intermediate Algebra
22326	MATH 80	Intermediate Algebra
20323	MATH 80A	Intermediate Algebra I
20325	MATH 80A	Intermediate Algebra I
20326	MATH 80A	Intermediate Algebra I
20328	MATH 80A	Intermediate Algebra I
20734	MATH 80A	Intermediate Algebra I
29066	MATH 80A	Intermediate Algebra I
20330	MATH 80B	Intermediate Algebra II
20331	MATH 80B	Intermediate Algebra II
20332	MATH 80B	Intermediate Algebra II
20334	MATH 80B	Intermediate Algebra II
20737	MATH 80B	Intermediate Algebra II
29067	MATH 80B	Intermediate Algebra II
20338	MATH 112	Elementary Statistics
20339	MATH 112	Elementary Statistics
22042	MATH 112	Elementary Statistics
21301	MATH 112	Elementary Statistics
21302	MATH 112	Elementary Statistics
24343	MATH 112	Elementary Statistics
24344	MATH 112	Elementary Statistics
24346	MATH 112	Elementary Statistics
26199	MATH 112	Elementary Statistics
26918	MATH 112	Elementary Statistics
26919	MATH 112	Elementary Statistics
27341	MATH 112	Elementary Statistics
27342	MATH 112	Elementary Statistics
28157	MATH 112	Elementary Statistics
28842	MATH 112	Elementary Statistics
29038	MATH 112	Elementary Statistics
29039	MATH 112	Elementary Statistics
29044	MATH 112	Elementary Statistics
29371	MATH 112	Elementary Statistics
29373	MATH 112	Elementary Statistics
29374	MATH 112	Elementary Statistics
29375	MATH 112	Elementary Statistics
29376	MATH 112	Elementary Statistics
29379	MATH 112	Elementary Statistics
29383	MATH 112	Elementary Statistics
28736	MATH 112	Elementary Statistics
30687	MATH 112	Elementary Statistics
30701	MATH 112	Elementary Statistics
29369	MATH 112	Elementary Statistics
29377	MATH 112	Elementary Statistics
29389	MATH 112	Elementary Statistics
29391	MATH 112	Elementary Statistics
20343	MATH 114	College Algebra
25895	MATH 114	College Algebra
20739	MATH 114	College Algebra
20741	MATH 114	College Algebra
20742	MATH 114	College Algebra



## DISTANCE EDUCATION COURSES (CONTINUED)

22391	MATH 114	College Algebra
23415	MATH 114	College Algebra
29033	MATH 114	College Algebra
29392	MATH 114	College Algebra
29399	MATH 114	College Algebra
29400	MATH 114	College Algebra
21274	MATH 116	Calculus for Managerial, Biological and Social Sciences
29403	MATH 116	Calculus for Managerial, Biological and Social Sciences
20349	MATH 140	Trigonometry
22809	MATH 140	Trigonometry
20350	MATH 140	Trigonometry
20744	MATH 140	Trigonometry
20745	MATH 140	Trigonometry
20746	MATH 140	Trigonometry
20747	MATH 140	Trigonometry
29012	MATH 140	Trigonometry
30336	MATH 140	Trigonometry
29737	MATH 140	Trigonometry
29365	MATH 140	Trigonometry
26461	MATH 155	Precalculus
26463	MATH 155	Precalculus
30329	MATH 155	Precalculus
20355	MATH 170	Analytic Geometry and Calculus I
22255	MATH 170	Analytic Geometry and Calculus I
28408	MATH 170	Analytic Geometry and Calculus I
29034	MATH 170	Analytic Geometry and Calculus I
20357	MATH 190	Analytic Geometry and Calculus II
20750	MATH 190	Analytic Geometry and Calculus II
22393	MATH 190	Analytic Geometry and Calculus II
29014	MATH 190	Analytic Geometry and Calculus II
29705	MATH 190	Analytic Geometry and Calculus II
27210	MATH 225	Calculus III
24348	MATH 250	Linear Algebra and Differential Equations
30340	MATH 250	Linear Algebra and Differential Equations

### MEDICAL ASSISTANT

20714	MA 60	Introduction to Medical Assisting
24195	MA 63	Health Insurance Coding and Billing
20716	MA 64	Medical Office Assisting
26861	MA 66	Medications and Specialties
26863	MA 67	Medical Office Administration
20277	MA 161	Medical Terminology
20718	MA 161	Medical Terminology
21341	MA 161	Medical Terminology

### MUSIC

20361	MUS 100	Music Appreciation
23964	MUS 100	Music Appreciation
24371	MUS 100	Music Appreciation
27048	MUS 100	Music Appreciation
20363	MUS 101	Introduction to World Music
20757	MUS 104B	History of Rock Music
21860	MUS 104B	History of Rock Music
25998	MUS 104B	History of Rock Music
22128	MUS 104B	History of Rock Music
20364	MUS 105	Music Fundamentals
22711	MUS 105	Music Fundamentals
20365	MUS 105	Music Fundamentals
20366	MUS 105	Music Fundamentals
20368	MUS 105	Music Fundamentals
27692	MUS 105	Music Fundamentals
24373	MUS 110	Music Technology Fundamentals
20370	MUS 112	Elementary Piano I
21014	MUS 112	Elementary Piano I
20759	MUS 112	Elementary Piano I
21161	MUS 112	Elementary Piano I
21297	MUS 112	Elementary Piano I
21309	MUS 112	Elementary Piano I
21478	MUS 112	Elementary Piano I
21479	MUS 112	Elementary Piano I
21312	MUS 113	Elementary Piano II
21313	MUS 113	Elementary Piano II
21666	MUS 113	Elementary Piano II
21667	MUS 113	Elementary Piano II
20372	MUS 114	Intermediate Piano I
21016	MUS 114	Intermediate Piano I
21668	MUS 114	Intermediate Piano I
21669	MUS 114	Intermediate Piano I
21310	MUS 115	Intermediate Piano II
21311	MUS 115	Intermediate Piano II
21670	MUS 115	Intermediate Piano II
21671	MUS 115	Intermediate Piano II
20373	MUS 116	Voice I
21017	MUS 116	Voice I
20907	MUS 116	Voice I
21198	MUS 116	Voice I
20908	MUS 117	Voice II
21199	MUS 117	Voice II
21672	MUS 117	Voice II
21673	MUS 117	Voice II
21674	MUS 118	Voice III
21675	MUS 118	Voice III
21200	MUS 118	Voice III
21329	MUS 118	Voice III
21295	MUS 119	Voice IV
21296	MUS 119	Voice IV
21678	MUS 119	Voice IV
21679	MUS 119	Voice IV
21304	MUS 120	Elementary Guitar I
21305	MUS 120	Elementary Guitar I
21306	MUS 121	Elementary Guitar II
21307	MUS 121	Elementary Guitar II
22033	MUS 122	Intermediate Guitar I
22034	MUS 122	Intermediate Guitar I
21317	MUS 123	Intermediate Guitar II
21318	MUS 123	Intermediate Guitar II
30322	MUS 143A	Songwriting
30323	MUS 143A	Songwriting
24367	MUS 144B	Electronic Music Production
24368	MUS 144B	Electronic Music Production
26420	MUS 146B	Mixing Techniques
26421	MUS 146B	Mixing Techniques
20377	MUS 148	Private Study/Technique
21021	MUS 148	Private Study/Technique
20378	MUS 149	Private Study/Musical Preparation
21022	MUS 149	Private Study/Musical Preparation
20379	MUS 150	Private Study/Performance Practice
21023	MUS 150	Private Study/Performance Practice
22035	MUS 151	Private Study/Recital Preparation
22036	MUS 151	Private Study/Recital Preparation
26428	MUS 153	The Art of Teaching Intermediate Piano
26422	MUS 156	Contemporary Music Notation
26423	MUS 156	Contemporary Music Notation
24385	MUS 180	Music Theory/Musicianship I
24386	MUS 180	Music Theory/Musicianship I
24361	MUS 200E	Beginning Band
24362	MUS 200E	Beginning Band
24363	MUS 203E	Community Band
24364	MUS 203E	Community Band
24957	MUS 204E	Orchestra
24958	MUS 204E	Orchestra
24959	MUS 205E	Community Orchestra
24960	MUS 205E	Community Orchestra
24961	MUS 206E	Stage Band
24962	MUS 206E	Stage Band
24963	MUS 207E	Jazz Ensemble
24964	MUS 207E	Jazz Ensemble
30666	MUS 208E	Pop/Rock Latin Ensemble
24967	MUS 210E	String Ensemble
24968	MUS 210E	String Ensemble
25036	MUS 216E	Piano Ensemble
25037	MUS 216E	Piano Ensemble
24971	MUS 218E	Community Chorus
24972	MUS 218E	Community Chorus
24975	MUS 219E	Collegiate Chorale
24976	MUS 219E	Collegiate Chorale
25547	MUS 280	Music Theory/Musicianship III
25548	MUS 280	Music Theory/Musicianship III

# DISTANCE EDUCATION COURSES (CONTINUED)

## NURSING

29073	NRS 25	Clinical Workshop 1
20859	NRS 26	Clinical Workshop 2
29075	NRS 48T	Elective Nursing - Tutorial
23691	NRS 57LA	Beginning Nursing Skills Lab
23692	NRS 57LB	Intermediate Nursing Skills Lab
23693	NRS 57LC	Advanced Intermediate Nursing Skills Lab
30560	NRS 80	Nursing Process Documentation
30561	NRS 80	Nursing Process Documentation
20860	NRS 210	Fundamentals of Nursing
20861	NRS 210	Fundamentals of Nursing
20862	NRS 210	Fundamentals of Nursing
20863	NRS 210	Fundamentals of Nursing
20865	NRS 210	Fundamentals of Nursing
27689	NRS 210	Fundamentals of Nursing
20911	NRS 212	Medical-Surgical Nursing I
20912	NRS 212	Medical-Surgical Nursing I
20913	NRS 212	Medical-Surgical Nursing I
20914	NRS 212	Medical-Surgical Nursing I
20915	NRS 212	Medical-Surgical Nursing I
21639	NRS 212	Medical-Surgical Nursing I
22196	NRS 215	Advanced Placement Bridge
20867	NRS 220	Medical-Surgical Nursing 3
20869	NRS 220	Medical-Surgical Nursing 3
20870	NRS 220	Medical-Surgical Nursing 3
24202	NRS 220	Medical-Surgical Nursing 3
25520	NRS 220	Medical-Surgical Nursing 3
30059	NRS 220	Medical-Surgical Nursing 3
20916	NRS 222	Maternal/Child Nursing
20917	NRS 222	Maternal/Child Nursing
21641	NRS 222	Maternal/Child Nursing
22146	NRS 222	Maternal/Child Nursing
22358	NRS 222	Maternal/Child Nursing
24203	NRS 222	Maternal/Child Nursing
20872	NRS 230	Psychosocial and Community Nursing
20873	NRS 230	Psychosocial and Community Nursing
20874	NRS 230	Psychosocial and Community Nursing
20875	NRS 230	Psychosocial and Community Nursing
20876	NRS 230	Psychosocial and Community Nursing
20877	NRS 230	Psychosocial and Community Nursing
30391	NRS 230	Psychosocial and Community Nursing
20918	NRS 232	Medical-Surgical Nursing 4
20919	NRS 232	Medical-Surgical Nursing 4
20920	NRS 232	Medical-Surgical Nursing 4
20921	NRS 232	Medical-Surgical Nursing 4
20922	NRS 232	Medical-Surgical Nursing 4
20923	NRS 232	Medical-Surgical Nursing 4
21405	NRS 251	Basic Adult Physical Assessment
21406	NRS 251	Basic Adult Physical Assessment
30562	NRS 251	Basic Adult Physical Assessment

## PHARMACY TECHNICIAN

23665	PHAR 56	Pharmacy Skills Lab Introduction
20772	PHAR 63	Pharmacy Operations II
23557	PHAR 64	Pharmacy Operations III
20774	PHAR 85	Pharmacy Technician Pharmacology II

## PHILOSOPHY

22579	PHIL 100	Introduction to Philosophy
20470	PHIL 100	Introduction to Philosophy
24058	PHIL 100	Introduction to Philosophy
20775	PHIL 100	Introduction to Philosophy
20776	PHIL 100	Introduction to Philosophy
29275	PHIL 100	Introduction to Philosophy
23785	PHIL 100	Introduction to Philosophy
20472	PHIL 100	Introduction to Philosophy
27746	PHIL 100	Introduction to Philosophy
21603	PHIL 102	Introduction to Ethics
28033	PHIL 102	Introduction to Ethics
28034	PHIL 102	Introduction to Ethics
21783	PHIL 103	Philosophical Reasoning: Critical Thinking in Philosophy
21782	PHIL 103	Philosophical Reasoning: Critical Thinking in Philosophy
21784	PHIL 103	Philosophical Reasoning: Critical Thinking in Philosophy

26554	PHIL 103	Philosophical Reasoning: Critical Thinking in Philosophy
28375	PHIL 103	Philosophical Reasoning: Critical Thinking in Philosophy
29126	PHIL 103	Philosophical Reasoning: Critical Thinking in Philosophy
21422	PHIL 104	Philosophy of Cultural Diversity: Challenge and Change
20474	PHIL 104	Philosophy of Cultural Diversity: Challenge and Change
26382	PHIL 104	Philosophy of Cultural Diversity: Challenge and Change
29568	PHIL 104	Philosophy of Cultural Diversity: Challenge and Change
20778	PHIL 106	Introduction to Logic
27009	PHIL 130	History of Ancient Philosophy
20779	PHIL 200	World Religions
22885	PHIL 203	Philosophy of Religion
30491	PHIL 205	Introduction to Bioethics

## PHOTOGRAPHY

20480	PHOT 110	Introduction to Digital Photography
21096	PHOT 110	Introduction to Digital Photography
24040	PHOT 110	Introduction to Digital Photography
24041	PHOT 110	Introduction to Digital Photography
30587	PHOT 110	Introduction to Digital Photography
30588	PHOT 110	Introduction to Digital Photography
30589	PHOT 110	Introduction to Digital Photography
30590	PHOT 110	Introduction to Digital Photography
26850	PHOT 112	Intermediate Digital Photography
26851	PHOT 112	Intermediate Digital Photography
30591	PHOT 112	Intermediate Digital Photography
30592	PHOT 112	Intermediate Digital Photography
30643	PHOT 122	Color Photography
30644	PHOT 122	Color Photography
30324	PHOT 130	Photo Journalism
29081	PHOT 150	Photography and Society
25550	PHOT 160	History of Photography

## PHYSICAL EDUCATION

30267	PEX 120	Cardio Kickboxing
30268	PEX 120	Cardio Kickboxing
30275	PEX 122	Cross Fit Training and Functional Exercises
30276	PEX 122	Cross Fit Training and Functional Exercises
30277	PEX 124	Personal Fitness Program
30278	PEX 124	Personal Fitness Program
24758	PEX 124	Personal Fitness Program
24759	PEX 124	Personal Fitness Program
24764	PEX 124	Personal Fitness Program
24765	PEX 124	Personal Fitness Program
30279	PEX 124	Personal Fitness Program
30280	PEX 124	Personal Fitness Program
26256	PEX 124	Personal Fitness Program
26257	PEX 124	Personal Fitness Program
25064	PEX 130	Weight Management
25065	PEX 130	Weight Management
30281	PEX 132	Indoor Cycling
30282	PEX 132	Indoor Cycling
30283	PEX 132	Indoor Cycling
30284	PEX 132	Indoor Cycling
30285	PEX 134	Body Sculpting
30286	PEX 134	Body Sculpting
30287	PEX 135	Ropes, Bands, and Suspension Training
30288	PEX 135	Ropes, Bands, and Suspension Training
30428	PEX 136	Stretching and Relaxation
30429	PEX 136	Stretching and Relaxation
25571	PEX 138	Walking for Fitness
25572	PEX 138	Walking for Fitness
27160	PEX 139	Walking/Jogging for Fitness
27161	PEX 139	Walking/Jogging for Fitness
24787	PEX 140	Jogging, Basics
24788	PEX 140	Jogging, Basics
24791	PEX 141	Jogging for Fitness, Beginning
24792	PEX 141	Jogging for Fitness, Beginning
24797	PEX 145	Circuit Weight Training, Beginning
24798	PEX 145	Circuit Weight Training, Beginning
24821	PEX 147	Personal Self Defense
24822	PEX 147	Personal Self Defense
30294	PEX 148	Brazilian Jiu Jitsu
30295	PEX 148	Brazilian Jiu Jitsu
25938	PEX 149	Tae Kwon Do, Beginning

## DISTANCE EDUCATION COURSES (CONTINUED)

25939	PEX 149	Tae Kwon Do, Beginning
24827	PEX 151	Yoga
24828	PEX 151	Yoga
24831	PEX 151	Yoga
24832	PEX 151	Yoga
24837	PEX 151	Yoga
24838	PEX 151	Yoga
27718	PEX 151	Yoga
27719	PEX 151	Yoga
28002	PEX 151	Yoga
28003	PEX 151	Yoga
26266	PEX 152	Gentle Yoga
26267	PEX 152	Gentle Yoga
27099	PEX 152	Gentle Yoga
27100	PEX 152	Gentle Yoga
28004	PEX 152	Gentle Yoga
28005	PEX 152	Gentle Yoga
29334	PEX 152	Gentle Yoga
29335	PEX 152	Gentle Yoga
29336	PEX 152	Gentle Yoga
29337	PEX 152	Gentle Yoga
27724	PEX 155	PIYo Introduction to Pilates and Yoga
27725	PEX 155	PIYo Introduction to Pilates and Yoga
24841	PEX 156	Pilates Conditioning
24842	PEX 156	Pilates Conditioning
24863	PEX 165	Basketball, Novice
24864	PEX 165	Basketball, Novice
24865	PEX 166	Basketball, Beginning
24866	PEX 166	Basketball, Beginning
26484	PEX 167	Bowling, Beginning
26485	PEX 167	Bowling, Beginning
24870	PEX 176	Golf, Beginning
24871	PEX 176	Golf, Beginning
24904	PEX 240	Jogging for Fitness, Intermediate
24905	PEX 240	Jogging for Fitness, Intermediate
24910	PEX 245	Circuit Weight Training, Intermediate/Advanced
24911	PEX 245	Circuit Weight Training, Intermediate/Advanced
25940	PEX 249	Tae Kwon Do, Intermediate/Advanced
25941	PEX 249	Tae Kwon Do, Intermediate/Advanced
24924	PEX 265	Basketball, Intermediate
24925	PEX 265	Basketball, Intermediate
24926	PEX 266	Basketball, Advanced
24927	PEX 266	Basketball, Advanced
26486	PEX 267	Bowling, Intermediate/Advanced
26487	PEX 267	Bowling, Intermediate/Advanced
24928	PEX 276	Golf, Intermediate/Advanced

### PHYSICAL THERAPIST ASSISTANT

30571	PTA 110	Introduction to Physical Therapy
-------	---------	----------------------------------

### PHYSICS

20481	PHYS 100	Elementary Physics
20482	PHYS 100	Elementary Physics
27957	PHYS 100	Elementary Physics
30213	PHYS 100	Elementary Physics

### PLASTICS/COMPOSITES MANUFACTURING TECHNOLOGY

27124	PMT 51	Composites Fabrication
30011	PMT 76	Vacuum Infusion Process (VIP)/Resin Transfer Molding (RTM)
30012	PMT 76	Vacuum Infusion Process (VIP)/Resin Transfer Molding (RTM)
22768	PMT 100	Plastics Technology
22769	PMT 100	Plastics Technology

### POLITICAL SCIENCE

23786	POL 101	American Political Institutions
20488	POL 101	American Political Institutions
20490	POL 101	American Political Institutions
20491	POL 101	American Political Institutions
20492	POL 101	American Political Institutions
20493	POL 101	American Political Institutions
20494	POL 101	American Political Institutions
20495	POL 101	American Political Institutions
23787	POL 101	American Political Institutions
20497	POL 101	American Political Institutions
23788	POL 101	American Political Institutions
20791	POL 101	American Political Institutions
30641	POL 101	American Political Institutions
20793	POL 101	American Political Institutions
20794	POL 101	American Political Institutions
21276	POL 101	American Political Institutions
23875	POL 101	American Political Institutions
22052	POL 101	American Political Institutions
30642	POL 101	American Political Institutions
20935	POL 101	American Political Institutions
21275	POL 101	American Political Institutions
23994	POL 101	American Political Institutions
20795	POL 101	American Political Institutions
20796	POL 201	Introduction to Political Science and American Government
24466	POL 201	Introduction to Political Science and American Government

### PSYCHOLOGY

20500	PSYC 101	General Introductory Psychology
20501	PSYC 101	General Introductory Psychology
20502	PSYC 101	General Introductory Psychology
20503	PSYC 101	General Introductory Psychology
20504	PSYC 101	General Introductory Psychology
25494	PSYC 101	General Introductory Psychology
20507	PSYC 101	General Introductory Psychology
20508	PSYC 101	General Introductory Psychology
28143	PSYC 101	General Introductory Psychology
29412	PSYC 101	General Introductory Psychology
27931	PSYC 101	General Introductory Psychology
22443	PSYC 101	General Introductory Psychology
29103	PSYC 101	General Introductory Psychology
21731	PSYC 101	General Introductory Psychology
27932	PSYC 101	General Introductory Psychology
27933	PSYC 101	General Introductory Psychology
27404	PSYC 103	Critical Thinking in Psychology
24468	PSYC 103	Critical Thinking in Psychology
25993	PSYC 103	Critical Thinking in Psychology
26061	PSYC 103	Critical Thinking in Psychology
26078	PSYC 103	Critical Thinking in Psychology
27278	PSYC 103	Critical Thinking in Psychology
27279	PSYC 103	Critical Thinking in Psychology
30383	PSYC 103	Critical Thinking in Psychology
26738	PSYC 103	Critical Thinking in Psychology
20513	PSYC 150	Personal and Social Adjustment
22308	PSYC 210	Elementary Statistics
22309	PSYC 210	Elementary Statistics
20804	PSYC 210	Elementary Statistics
20805	PSYC 210	Elementary Statistics
22888	PSYC 210	Elementary Statistics
22889	PSYC 210	Elementary Statistics
24469	PSYC 210	Elementary Statistics
24470	PSYC 210	Elementary Statistics
27929	PSYC 210	Elementary Statistics
27930	PSYC 210	Elementary Statistics
28144	PSYC 210	Elementary Statistics
28145	PSYC 210	Elementary Statistics
29104	PSYC 210	Elementary Statistics
29105	PSYC 210	Elementary Statistics
30663	PSYC 210	Elementary Statistics
30664	PSYC 210	Elementary Statistics
27002	PSYC 220	Research Methods
27003	PSYC 220	Research Methods
30385	PSYC 220	Research Methods
30386	PSYC 220	Research Methods

# DISTANCE EDUCATION COURSES (CONTINUED)

20518	PSYC 241	Introduction to Psychobiology
20519	PSYC 241	Introduction to Psychobiology
25994	PSYC 245	Drugs and Behavior
20521	PSYC 251	Developmental Psychology
21280	PSYC 251	Developmental Psychology
22022	PSYC 251	Developmental Psychology
25995	PSYC 251	Developmental Psychology
27280	PSYC 251	Developmental Psychology
22418	PSYC 261	Social Psychology
29273	PSYC 261	Social Psychology
24474	PSYC 261	Social Psychology
30029	PSYC 261	Social Psychology
20522	PSYC 271	Abnormal Psychology
30384	PSYC 271	Abnormal Psychology

## RADIO - TELEVISION

21430	RTV 151	Motion Pictures, Radio, and Television
28515	RTV 151	Motion Pictures, Radio, and Television
21373	RTV 152	Introduction to Broadcasting

## READING

30185	READ 101	Literacy and Learning Strategies for College Success
30653	READ 101	Literacy and Learning Strategies for College Success
30654	READ 101	Literacy and Learning Strategies for College Success
30655	READ 101	Literacy and Learning Strategies for College Success
30656	READ 101	Literacy and Learning Strategies for College Success
30657	READ 101	Literacy and Learning Strategies for College Success
30658	READ 101	Literacy and Learning Strategies for College Success
30659	READ 101	Literacy and Learning Strategies for College Success
30660	READ 101	Literacy and Learning Strategies for College Success
30661	READ 101	Literacy and Learning Strategies for College Success
29629	READ 101	Literacy and Learning Strategies for College Success
30184	READ 101	Literacy and Learning Strategies for College Success
30186	READ 101	Literacy and Learning Strategies for College Success
30187	READ 101	Literacy and Learning Strategies for College Success
21653	READ 103	Analysis and Critical Reading
25492	READ 103	Analysis and Critical Reading
24615	READ 103	Analysis and Critical Reading
29241	READ 103	Analysis and Critical Reading
30407	READ 103	Analysis and Critical Reading
30408	READ 103	Analysis and Critical Reading

## REAL ESTATE

21961	RE 101	Real Estate Principles
21962	RE 101	Real Estate Principles
21971	RE 101	Real Estate Principles
27450	RE 101	Real Estate Principles
24005	RE 120	Real Estate Finance
23871	RE 130	Real Estate Practice
21972	RE 130	Real Estate Practice
24431	RE 157	Real Estate Investments

## SOCIOLOGY

20550	SOC 101	Introductory Sociology Principles
21787	SOC 101	Introductory Sociology Principles
27443	SOC 101	Introductory Sociology Principles
20549	SOC 101	Introductory Sociology Principles
20553	SOC 101	Introductory Sociology Principles
20554	SOC 101	Introductory Sociology Principles
26427	SOC 101	Introductory Sociology Principles
20829	SOC 101	Introductory Sociology Principles
21607	SOC 101	Introductory Sociology Principles
20555	SOC 101	Introductory Sociology Principles
24480	SOC 101	Introductory Sociology Principles
20552	SOC 101	Introductory Sociology Principles
27749	SOC 101	Introductory Sociology Principles
24479	SOC 101	Introductory Sociology Principles
20830	SOC 110	Marriage and the Family
20556	SOC 110	Marriage and the Family

27983	SOC 110	Marriage and the Family
30640	SOC 120	Introduction to Human Sexuality
20561	SOC 120	Introduction to Human Sexuality
21604	SOC 201	Social Problems
26208	SOC 201	Social Problems
29128	SOC 202	Gender and Society
27750	SOC 202	Gender and Society
30639	SOC 202	Gender and Society
26209	SOC 205	Introduction to Social Research Methods
24481	SOC 210	American Minority Relations

## SPANISH

20562	SPAN 101	Elementary Spanish
21100	SPAN 101	Elementary Spanish
20563	SPAN 101	Elementary Spanish
21101	SPAN 101	Elementary Spanish
23948	SPAN 101	Elementary Spanish
23949	SPAN 101	Elementary Spanish
20564	SPAN 101	Elementary Spanish
21102	SPAN 101	Elementary Spanish
24591	SPAN 101	Elementary Spanish
24592	SPAN 101	Elementary Spanish
20832	SPAN 101	Elementary Spanish
21181	SPAN 101	Elementary Spanish
26981	SPAN 101	Elementary Spanish
26982	SPAN 101	Elementary Spanish
29343	SPAN 101	Elementary Spanish
29344	SPAN 101	Elementary Spanish
27923	SPAN 101	Elementary Spanish
27924	SPAN 101	Elementary Spanish
22351	SPAN 102	Elementary Spanish
22352	SPAN 102	Elementary Spanish
22682	SPAN 111	Elementary Spanish for Spanish Speakers
22683	SPAN 111	Elementary Spanish for Spanish Speakers
20568	SPAN 111	Elementary Spanish for Spanish Speakers
21106	SPAN 111	Elementary Spanish for Spanish Speakers
29345	SPAN 111	Elementary Spanish for Spanish Speakers
29346	SPAN 111	Elementary Spanish for Spanish Speakers
20569	SPAN 112	Elementary Spanish for Spanish Speakers
21107	SPAN 112	Elementary Spanish for Spanish Speakers
20570	SPAN 245	Introduction to Chicano/Mexican American Culture
20836	SPAN 245	Introduction to Chicano/Mexican American Culture

## THEATRE ARTS

23858	TH 101	Introduction to the Theatre
23432	TH 101	Introduction to the Theatre
25999	TH 101	Introduction to the Theatre
23433	TH 101	Introduction to the Theatre
26098	TH 101	Introduction to the Theatre
27416	TH 101	Introduction to the Theatre
20839	TH 101	Introduction to the Theatre
27417	TH 101	Introduction to the Theatre
21290	TH 101	Introduction to the Theatre
30595	TH 104	History and Appreciation of Musical Theatre
23640	TH 108	Improvisation for the Theatre
27696	TH 110	Fundamentals of Acting
27697	TH 110	Fundamentals of Acting
30596	TH 112	Script Analysis
28771	TH 123	Stage Make-Up
29608	TH 123	Stage Make-Up
25135	TH 130	Rehearsal and Performance for the Minor Role
25136	TH 130	Rehearsal and Performance for the Minor Role
25137	TH 130	Rehearsal and Performance for the Minor Role
25138	TH 130	Rehearsal and Performance for the Minor Role
25139	TH 131	Rehearsal and Performance for the Supporting Role
25140	TH 131	Rehearsal and Performance for the Supporting Role
25141	TH 131	Rehearsal and Performance for the Supporting Role
25142	TH 131	Rehearsal and Performance for the Supporting Role
25133	TH 132	Rehearsal and Performance for the Leading Roles
25134	TH 132	Rehearsal and Performance for the Leading Roles
26502	TH 133	Stage Crew Activity
26503	TH 133	Stage Crew Activity
20958	TH 150	Appreciation and History of the Motion Picture
21291	TH 150	Appreciation and History of the Motion Picture

## DISTANCE EDUCATION COURSES (CONTINUED)

23434	TH 150	Appreciation and History of the Motion Picture
27974	TH 150	Appreciation and History of the Motion Picture
29752	TH 150	Appreciation and History of the Motion Picture
20593	TH 151	Motion Pictures, Radio and Television
28514	TH 151	Motion Pictures, Radio and Television
29088	TH 212	Scene Study
29089	TH 212	Scene Study
30597	TH 226	Introduction to Scenic Design
30598	TH 226	Introduction to Scenic Design

### WELDING

23587	WELD 49	Welding Shop Math
27624	WELD 49	Welding Shop Math
27360	WELD 52	Pipe Welding Fundamentals
23588	WELD 59	Blueprint Reading for the Welding Trades
27357	WELD 59	Blueprint Reading for the Welding Trades
30611	WELD 100	Welding Fundamentals
30612	WELD 100	Welding Fundamentals
30689	WELD 100	Welding Fundamentals
20843	WELD 120	Beginning Arc Welding
25440	WELD 120	Beginning Arc Welding
26338	WELD 130	Gas Tungsten Arc Welding Fundamentals
20844	WELD 130	Gas Tungsten Arc Welding Fundamentals
20845	WELD 200	Intermediate Arc Welding

### WOMEN'S AND GENDER STUDIES

20606	WGS 101	Issues for Women in American Society
25739	WGS 101	Issues for Women in American Society
26452	WGS 102	Women and Religion
29108	WGS 102	Women and Religion
30665	WGS 103	Women, their Bodies and Health
27286	WGS 108	Women in Sports
27400	WGS 108	Women in Sports
29109	WGS 115	Gender, Communication, and the Digital Revolution
28198	WGS 115	Gender, Communication, and the Digital Revolution
29111	WGS 118	History of Women in Visual Arts
30390	WGS 140	Introduction to LGBT Studies
29112	WGS 202	Gender and Society
27753	WGS 202	Gender and Society
30638	WGS 202	Gender and Society
29640	WGS 206	Women in the Global Economy
29113	WGS 207	Women and Media
26384	WGS 208	Leadership for Women in Business
26385	WGS 208	Leadership for Women in Business
26386	WGS 208	Leadership for Women in Business

### WOODWORKING MANUFACTURING TECHNOLOGY

20602	WMT 101	Introduction to Woodworking
20849	WMT 101	Introduction to Woodworking
29265	WMT 102	Introduction to Solid Wood Casegoods
20850	WMT 103	Introduction to Tables
30355	WMT 130	Furniture Design
30356	WMT 130	Furniture Design
21470	WMT 151	Introduction to Faceframe Cabinetmaking
30353	WMT 151	Introduction to Faceframe Cabinetmaking
30622	WMT 153	32mm System of Cabinetmaking
30361	WMT 184	Introduction to Digital Fabrication
25457	WMT 201	Woodworking with Hand Tools



# SEXUAL AND GENDER-BASED MISCONDUCT

## POLICY ON AFFIRMATIVE CONSENT, SEXUAL ASSAULT, AND TITLE IX

Cerritos College is committed to providing a safe and secure environment for all members of the campus community. Board Policy and Administrative Procedure 3540: Sexual and Other Assaults on Campus, operationalize relevant State and Federal Laws. These cover sexual assaults including rape, sexual battery, and threat of sexual assault; dating violence; domestic violence; stalking; and failure to have affirmative consent. District response including claimant options, victim resources, case investigation, and administrative and law enforcement response are provided in Administrative Procedure 3540. Any student or employee who becomes a victim of sexual violence, dating violence, domestic violence, or stalking is encouraged to report the matter immediately to Dr. Valyncia C. Raphael, District Title IX Coordinator in the Office of Human Resource Services. The phone number for the Title IX Coordinator is (562) 860-2451, ext. 2276, and the email address is [TitleIXcoordinator@cerritos.edu](mailto:TitleIXcoordinator@cerritos.edu). Additional information is available at <https://www.cerritos.edu/title-ix>.

The District is dedicated to providing prompt and compassionate services. In the event of an incident, Student Health Services will provide confidential support services and direction. The phone number for Student Health Services is (562) 860-2451, ext. 2321. New Title IX Regulations in Spring 2020: The District's effort to implement the new requirements is ongoing. Please visit the Title IX website at <https://www.cerritos.edu/title-ix> for updated information.

For more information, please see Board Policy 3540 and Administrative Procedure 3540: Sexual and Other Assaults on Campus. This Policy and Procedure are on the Board Policy web page at: <https://www.cerritos.edu/board/policies>.

## AFFIRMATIVE CONSENT POLICY

Board Policy 3540 and 5500 define "affirmative consent" as affirmative, conscious, and voluntary agreement to engage in sexual activity. Lack of protest or resistance does not mean consent, nor does silence mean consent. Affirmative consent must be ongoing throughout a sexual activity and can be revoked at any time. The existence of a dating relationship between the persons involved, or the fact of past sexual relations between them, should never by itself be assumed to be an indicator of consent. People under 18 years old; incapacitated by drugs, alcohol, or medication; asleep, unconscious or otherwise unable to understand the fact, nature, or extent of the sexual activity cannot give consent. Failure, as a person involved in sexual activity, to ensure mutual, affirmative consent

throughout sexual activity constitutes good cause for discipline, including but not limited to the removal, suspension, or expulsion of a student. Information about violators of this policy are encouraged to report this matter immediately to the Director of Diversity, Compliance, and Title IX Coordinator in the Office of Human Resources or the Campus Police. The number for the Campus Police is (562) 860-2451, ext. 2325.

## SEXUAL HARASSMENT

It is the policy of the Cerritos Community College District to provide an educational, employment, and business environment free of unwelcome sexual advances, requests or offers for sexual favors, and other verbal or physical conduct or communications constituting sexual harassment, as defined and otherwise prohibited by federal and state statutes and Board Policy.

The Board of Trustees and the President-Superintendent have provided regulations and procedures to implement this policy and the regulations and procedures are included as a part of the District's Equal Employment Opportunity Plan and Board Policy.

It is a violation of Board Policy for anyone who is authorized to recommend or take personnel or academic actions affecting an employee or student, or who is otherwise authorized to transact business or perform other acts or services on behalf of the Cerritos Community College District, to engage in sexual harassment as defined in Board Policy or as described below.

Sexual harassment occurs when unwelcome sexual advances, requests for sexual favors and other verbal or physical conduct of a sexual nature takes place and:

1. Is made explicitly or implicitly a term or condition of an individual's educational status or employment; or
2. Is used as a basis for educational or employment decisions affecting such individual; or
3. Has the purpose or effect of unreasonably interfering with an individual's work performance or creating an intimidating, hostile or offensive educational or working environment; or
4. Is used as the basis for any decision affecting the individual regarding benefits, services, honors, programs, or activities available at or through the District. Informal and formal complaints under this policy shall be processed through the District's Administrative Procedure 3435: Discrimination and Harassment Investigations, through the Director of Diversity, Compliance, and Title IX Coordinator. The District's Policies and Procedures are available on the website at <https://www.cerritos.edu/board/policies>.

## // Stay Falcon Safe! //

**We are Falcons! We always keep our nest safe and look out for each other.**

<b>IF YOU ARE EXPERIENCING</b> <ul style="list-style-type: none"><li>• Stalking</li><li>• Bullying, verbal or written threats</li><li>• Cyberbullying</li><li>• Dating or domestic violence</li><li>• Sexual or physical assault</li></ul>	<b>HELP IS AVAILABLE</b> <p><b>Dial 562-860-2451 plus the extension below:</b></p> <b>On-Campus Resources</b> <ul style="list-style-type: none"><li>• Student Health Services: Ext. 2321</li><li>• Campus Police: 911 or Ext. 3076</li><li>• Student Conduct and Grievances: Ext. 2473</li><li>• Title IX, including Sexual Harassment: Ext. 2276</li><li>• Bicycle Safety and Theft Prevention: Ext. 3076</li></ul>
--	--

# NOTIFICATION OF RIGHTS UNDER FERPA

The Family Educational Rights and Privacy Act (FERPA) affords students certain rights with respect to their education records. These rights include:

- 1) The right to inspect and review the student's education records within 45 days of the day the College receives a request for access.

A student should submit to the registrar or designee a written request that identifies the record(s) the student wishes to inspect. The registrar will make arrangements for access and notify the student of the time and place where the records may be inspected. If the records are not maintained by the registrar, the registrar shall advise the student of the correct official to whom the request should be addressed.

- 2) The right to request the amendment of the student's education records that the student believes are inaccurate, misleading, or otherwise in violation of the student's privacy rights under FERPA.

A student who wishes to ask the College to amend a record should write the registrar, clearly identify the part of the record the student wants changed, and specify why it should be changed.

If the College decides not to amend the record as requested, the College will notify the student in writing of the decision and the student's right to a hearing regarding the request for amendment. Additional information regarding the hearing procedures will be provided to the student when notified of the right to a hearing.

- 3) The right to provide written consent before the College discloses personally identifiable information from the student's education records, except to the extent that FERPA authorizes disclosure without consent.

The College discloses education records without a student's prior written consent under the FERPA exception for disclosure to school officials with legitimate educational interests. A school official is a person employed by the College in an administrative, supervisory, academic or research, or support staff position (including law enforcement unit personnel and health staff); a person or company with whom the College has contracted as its agent to provide a service instead of using College employees or officials (such as an attorney, auditor, or collection agent); or a student serving on an official committee, such as a disciplinary or grievance committee, or assisting another school official in performing his or her tasks.

A school official has a legitimate educational interest if the official needs to review an education record in order to fulfill his or her professional responsibilities for the College. The College may also disclose education records without consent to officials of another school in which a student seeks or intends to enroll.

- 4) The right to file a complaint with the U.S. Department of Education concerning alleged failures by the College to comply with the requirements of FERPA. The name and address of the office that administers FERPA is:

Family Policy Compliance Office  
U.S. Department of Education  
400 Maryland Avenue, SW  
Washington, DC 20202-5901

## DIRECTORY INFORMATION

Cerritos College will not release personal data about students without their prior written consent except to persons and agencies authorized by law. The college may make an exception to legitimate inquiries, by providing general directory information to include: name • major field of study • class level • dates of attendance • degrees and awards received • participation in officially recognized activities and sports • weight and height of members of athletic teams, and • previous educational institutions attended.

## STUDENT RECORDS CONSENT

Cerritos College may permit access to student records to any person for whom the student has executed written consent specifying the records to be released and identifying the party or parties to whom the records may be released. Such consent must be signed and dated by the student. The recipient must be notified that the transmission of the information to others is prohibited (California Administrative Regulations, Title 5, Section 54616).

## WITHHOLDING OF STUDENT RECORDS

Student records may be withheld pending satisfaction of certain requirements, per Board Policy and Administrative Procedure 5035.

*Reference: Board Policy and Administrative Procedure 5040*

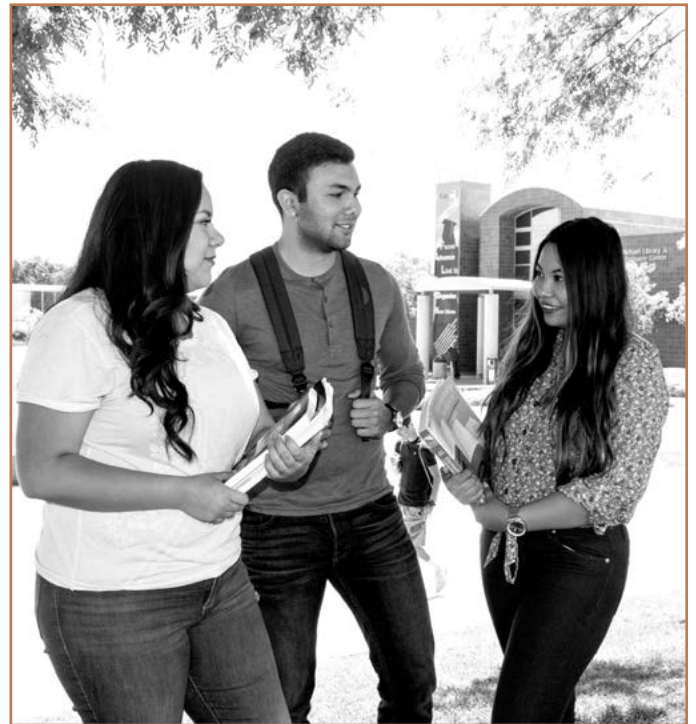

# GENERAL EDUCATION REQUIREMENTS FOR THE ASSOCIATE DEGREE AND FOR TRANSFER TO THE CALIFORNIA STATE UNIVERSITY AND UNIVERSITY OF CALIFORNIA

---

Requirements for the Associate in Arts (A.A.) Degree at Cerritos College can be met in one of three different ways: Plan A, B, or C.

**PLAN A** is designed primarily for those students interested in preparing for a vocational career upon graduation. Plan A may also be used by university transfer students and for students in vocational majors who may possibly wish to transfer in the future; however, there are courses listed under Plan A that are not transferable for general education credit to the four-year universities. Therefore, students wishing to use this option should see a Cerritos College counselor for advice in selecting the A.A. General Education plan that, in combination with a major, will best match their educational and career goals. Please see the Plan A degree description page for further details.

**PLAN B** is designed primarily for students who will transfer to a California State University (CSU) campus and are not interested in attending a University of California campus. Students may use this plan (with one caveat) to combine completion of both the Associate in Arts general education requirements, and the California State University (CSU) General Education Certification pattern. Students should see a counselor for advice on selecting the A.A. General Education plan that, in combination with a major, will best match their educational and career goals. Please see the Plan B degree description page for further details.

**PLAN C** is designed primarily for students who intend to transfer to the University of California (UC), or who are undecided between transferring to the University of California or the California State University. Students may use this plan to combine completion of both the A.A. degree general education requirements and the Intersegmental General Education Transfer Curriculum (IGETC) requirements. Plan C may not be recommended for some majors at certain CSU or UC campuses. Please see the Plan C description page for further details.

*The significant differences between Plan A, Plan B, and Plan C are:*

**Plan A** requires the completion of a minimum of 18 units of identified general education courses and requirements and a minimum of 18 units of specified “major” courses, as well as proficiency requirements and electives if necessary, to total a minimum of 60 degree applicable units.

**Plan B** requires a minimum of 39 units of identified CSU general education courses and requirements plus specified major courses, the health and wellness proficiency requirement, and elective courses if necessary, for a minimum of 60 degree applicable units.

If a student only wishes to transfer at an upper division level and is not seeking an A.A. degree, a minimum of 60 CSU transferable units is required (see transfer requirements for CSU and your counselor).

**Plan C** requires a minimum of 34 (UC) or 37 (CSU) units of identified general education courses and requirements plus specified major courses, the health and wellness proficiency requirement, and electives if necessary, to total a minimum of 60 degree applicable units.

If a student only wishes to transfer at an upper division level and is not seeking an A.A. degree, a minimum of 60 UC transferable units is required (see IGETC, UC transfer requirements, and your counselor).

There are important differences among the three plans. In order to select the plan that best meets each individual’s A.A. and transfer goals, students should see a Cerritos College counselor.





# GENERAL EDUCATION REQUIREMENTS FOR THE ASSOCIATE DEGREE

## Associate in Arts Degree General Education 2020-21 Plan A Degree and/or Career Option

A total of 60 degree applicable units, including the following requirements, must be completed to qualify for the A.A. degree:

- MAJOR PROGRAM REQUIREMENTS:**  
Complete all requirements for the chosen major program under "Major Requirements" in the Cerritos College Catalog.
- MATHEMATICS PROFICIENCY REQUIREMENT:**  
The requirements for the Math Proficiency can be met by one of the following options:
  - Pass Math 75, Math 80, Math 80B, a transfer-level math course or Psyc 210 with a grade of "C" or higher or "Pass" at Cerritos College.
  - Pass a math course equivalent to Math 75, Math 80, Math 80B, a transfer-level math course or Psyc 210 with a grade of "C" or higher or "Pass" at another accredited college.
  - Receive a score of 3 or better on a Math AP exam (AP Statistics, AP Calculus AB, AP Calculus BC).
  - Receive credit by exam for Math 75 or Math 80 at Cerritos College.
- READING PROFICIENCY REQUIREMENT:**  
This requirement can be met by one of the following options:
  - Completion of READ 54 or READ 97 or READ 102 or equivalent with a grade of "C" or higher or "Pass".
  - For other options, see your counselor.
- WRITING PROFICIENCY REQUIREMENT:**  
Completion of ENGL 100 or ENGL 100S or equivalent with a grade of "C" or higher or "Pass".
- HEALTH AND WELLNESS PROFICIENCY REQUIREMENT:**  
This requirement can be met by one of the following options:
  - Completion with a grade of Pass, or "C", or higher of at least one unit of a course from the approved department list below:  
Athletics 200L, 201LA, 201LB, 201LC, 202L, 203LA, 203LB, 203LC, 204L, 205LA, 205LB, 205LC, 205LD, 205LE, 206L, 207LA, 207LB, 207LC, 208L, 209LA, 209LB, 209LC, 210L, 211LA, 211LB, 211LC, 212L, 213LA, 213LB, 213LC, 214L, 215LA, 215LB, 215LC, 216L, 217LA, 217LB, 217LC, 218L, 219LA, 219LB, 219LC, 220L, 221LA, 221LB, 221LC, 221LD, 222L, 223LA, 223LB, 223LC, 223LD, 224L, 225LA, 225LB, 225LC, 225LD, 226L, 227LA, 227LB, 227LC, 228L, 229LA, 229LB, 229LC, 230L, 231LA, 231LB, 231LC, 232L, 233LA, 233LB, 233LC, 234L, 235LA, 235LB, 235LC, 235LD, 236L, 237LA, 237LB, 237LC, 240, 241, 242  
Dance 115  
Kinesiology 100, 102, 104, 106, 120, 121, 122, 123, 130, 131, 132, 133, 134, 200, 202, 203, 206, 207, 210  
Physical Education Exercise 100, 100A, 101, 102, 103, 103A, 104, 105, 106, 106A, 107, 107A, 108, 109, 110, 111, 112, 113, 116, 117, 118, 119, 120, 121, 122, 124, 126, 130, 132, 134, 135, 136, 137, 138, 139, 140, 140D, 141, 142, 145, 147, 148, 149, 150, 151, 152, 153, 155, 156, 157, 161, 162, 163, 165, 166, 167, 169, 170, 171, 172, 176, 177, 178, 179, 181, 184, 185, 186, 188, 189, 191, 192, 194, 240, 245, 246, 249, 261, 263, 265, 266, 267, 271, 272, 274, 276, 278, 281, 282, 284, 285, 288, 289, 291, 292  
Other courses that will meet the requirement include Dance 102, 103, 104, 105, 106A, 106B, 106C, 107, 108A, 108B, 108C, 109, 110, 112, 120, 121, 122, 123, 124, 125, 126, 127, 128, 130, 130A, 130B, 133, 134, 135, 136, 140, 141, 142, 143, 144, 150, 151  
b. Completion of HED 100, 101, 103, 105 or 200; HO 100 or 152; CDEC 161; or WGS 103.  
c. Enrollment and completion of Allied Health program (DA, DH, RN, PTA, Pharm Tech, MA).  
d. For other options, see your counselor.
- GENERAL EDUCATION REQUIREMENTS: PLAN A 18 UNITS**
  - NATURAL SCIENCES: 3 UNITS MINIMUM FROM EITHER PHYSICAL SCIENCES OR BIOLOGICAL SCIENCES**
    - Physical Sciences**  
Astronomy 102, 103, 104, 105L (lab), 106  
Chemistry 100 (lab), 110 (lab), 111 (lab), 112 (lab)  
Earth Science 101, 102 (lab), 104, 104L (lab), 106, 110 (lab)  
Energy 100  
Geography 101, 101L (lab), 103  
Geology 101 (lab), 102, 102L (lab), 103, 103L (lab), \*\*105L (lab), 201 (lab), 204, 207 (lab), 208, 209  
Physical Science 100, 112 (lab)  
Physics 100 (lab), 101 (lab), 102 (lab), 201 (lab), 202 (lab), 203 (lab)
    - Biological Sciences**  
Anatomy and Physiology 120 (lab), 150 (lab), 151 (lab), 200 (lab), 201 (lab)  
Anthropology \*\*110, 115, 115L (lab)  
Biology \*\*\*105, \*\*\*110 (lab), 115 (lab), 120 (lab), 200 (lab), 201 (lab)  
Botany 120 (lab)  
Microbiology 200 (lab)  
Psychology 241  
Zoology 120 (lab)
  - SOCIAL AND BEHAVIORAL SCIENCES: 3 UNITS MINIMUM**  
**NOTE: Completion of a U.S. history or government course which fulfills the California State University requirement taken at any accredited institution may be used in lieu of the course requirement.**  
One course from Section B1 or B2 is required.
    - History 101, 102, 103  
(This requirement can be met by successfully passing the College Board's Advanced Placement Exam, U.S. History. Unit credit is awarded for passing the AP exam option with a score of 3 or higher.)
    - Political Science 101 or 201  
(This requirement can be met by successfully passing the College Board's Advanced Placement exam, U.S. Government and Politics. Unit credit is awarded for passing the Advanced Placement exam option with a score of 3 or higher.)

# GENERAL EDUCATION REQUIREMENTS FOR THE ASSOCIATE DEGREE

---

- (3) Social and Behavioral Sciences  
 Administration of Justice 101  
 American Sign Language 220  
 Anthropology 100, 120, 170, 200, 201, 202, 203, 205, 206  
 Business Administration \*\*\*100, \*\*101, \*\*208  
 Child Development 110  
 Child Development/Early Childhood \*\*113  
 Communication Studies 110, 115  
 Counseling \*\*150, \*\*\*200  
 Economics 101, 102, 201, 201M, 202, 202M, 204  
 Environmental Policy 200  
 Finance \*\*125  
 Geography 102, 105, 140  
 Health Education \*\*\*+103  
 History 110, 120, 204, 210, \*\*\*220, \*\*\*221, 230, 235, 241, 242, 245, 246, 250, 255, 260, 265, \*\*270, 275  
 Humanities 107  
 Journalism \*\*\*100  
 Kinesiology +108, \*\*\*211  
 Political Science 110, 210, 220, 230, 240, \*\*\*250, \*\*\*260, \*\*280  
 Psychology 101, 150, 251, 261, 271, \*\*\*275  
 Reading \*\*\*101  
 Sociology 101, 110, 120, 201, 202, 205, 210, 215, \*\*225, \*\*\*230, 250  
 Speech Language Pathology \*\*105  
 Women's and Gender Studies 101, \*\*\*+103, 105, 107, +108, 115, \*\*140, 202, 204, 205, 206, \*\*208, 209, 250
- c. FINE ARTS AND HUMANITIES: 3 UNITS MINIMUM FROM EITHER FINE ARTS OR HUMANITIES
- (1) FINE ARTS  
 Architecture \*\*110, 112  
 Art 100, 101, 102, 103, 104, 105A, 105B, 106, 107, \*108, \*109, \*\*\*110, 113, \*\*\*116, 118, \*\*119A, \*\*\*120, \*\*\*130A, \*\*\*150, \*\*186, \*\*192, 193, \*\*200  
 Communication Studies \*\*148  
 Dance 100, 101  
 Film 159  
 Humanities \*108, \*109, \*\*200  
 Music 100, 101, \*\*\*102, 103, 104, 104B, 105, 180  
 Photography \*\*\*100, 160  
 Theatre 101, 102, 103, 104, \*\*110, 150, RTV/TH \*\*\*151, RTV \*\*\*152  
 Women's and Gender Studies 118
- (2) HUMANITIES  
 American Sign Language \*\*\*110, 111, \*\*\*210, \*\*\*211  
 Art \*108, \*109, 124, 125, 207  
 Chinese \*\*\*101, 102, 201, 202, 260  
 Communication Studies \*\*\*140  
 English 102, 106, 221A, 221B, 222, 223, 224, 225, 226, 227, 228, 230A, 230B, \*\*\*231, 232, 233, 234, 235, 236, 237, 238, 239, \*\*242, \*\*243, \*\*244, 245, 246A, 246B, \*\*247, \*\*\*248A, 248B, 249  
 French \*\*\*101, \*\*\*102, 201, 202, \*\*\*203, 281, 282, 283, 285  
 German \*\*\*101, 102, 201, 202
- Humanities 100, \*\*102, \*108, \*109, 125  
 Japanese \*\*\*101, 102, \*\*\*201, \*\*\*202  
 Philosophy 100, 102, 104, 105, 107, 108, 109, 130, 140, 200, 201, 203, 204, 205, 206  
 Photography 150  
 Spanish \*\*\*101, 102, \*\*\*111, 112, 201, 202, 206, 210, 245, 260, 285  
 Women's and Gender Studies 102, 109, 207
- d. LANGUAGE AND RATIONALITY: 6 UNITS MINIMUM  
 Select at least three units from Section D1 and three units from Section D2:
- (1) ENGLISH COMPOSITION  
 English 100, 100S
- (2) COMMUNICATION AND ANALYTICAL THINKING  
 Business Communication \*\*148  
 Communication Studies \*\*60, 100, 103, 120, \*\*\*125, 130, 132  
 Computer and Information Sciences \*\*101, \*\*102, \*\*103  
 Engineering Design Technology \*\*131  
 English 103, 110  
 Mathematics \*\*80, \*\*80B, \*\*\*110A, \*\*\*110B, 112, 114, 115, 116, \*\*\*140, 155, 160, 170, 190, 225, 250  
 Philosophy 103, \*\*\*106, \*\*160  
 Psychology 103, 210  
 Reading 103
- e. Select an additional general education course from those listed above or a course from Plan B or Plan C so that the earned general education units total at least 18.
- \* These courses appear in more than one category, but may only be counted once.
  - \*\* These courses do not meet the General Education Requirements for CSU or IGETC.
  - \*\*\* These courses do not meet the General Education Requirements for IGETC.
  - + These courses are cross-listed with another course. See individual cross-listed course descriptions in the Cerritos College catalog. Cross-listed courses may only receive credit once.

***NOTE: The preceding graduation requirements apply to students who were in attendance during the 2020-21 school year and thereafter. Students who enrolled prior to Fall 2020 and who have maintained continuous attendance at Cerritos College have the option of meeting the current requirements or those in effect at the time continuous attendance began.***

# GENERAL EDUCATION REQUIREMENTS FOR THE ASSOCIATE DEGREE AND FOR TRANSFER TO THE CALIFORNIA STATE UNIVERSITY

## Associate in Arts Degree General Education 2020-21 Plan B and/or The General Education Certification Requirements For The Bachelor's Degree At The California State University

Plan B is designed primarily for students who will transfer to a California State University (CSU) campus and are not interested in attending a University of California campus. Students may use this plan to combine completion of both the Associate in Arts general education requirements (with one caveat) and the CSU General Education Certification pattern. Students should see a counselor for advice on selecting the A.A. General Education plan that, in combination with a major, will best match their educational and career goals.

To earn an Associate in Arts Degree using Plan B, students must complete a minimum of 60 degree applicable units with an overall grade point average of "C" (2.0) or higher, which must include the specified general education requirements and designated courses for a major. The Health and Wellness Proficiency requirement must be completed (see description in Plan A).

However, a student may not use Plan B to fulfill the Math Proficiency Requirement for a local, regular (non-AAT/AST) degree if they have taken FIN 125M, Personal Finance. They would have to meet one of the criteria specified in the Math Proficiency Requirement section for Plan A. Students should consult with a counselor if they have questions about this.

If a student wishes only to transfer and is not seeking an A.A. degree, they can follow the requirements below; however, there are no proficiencies required for CSUGE certification.

It should be noted that completion of the CSU General Education Certification is not required for admission to the CSU, nor is it the only way to fulfill the lower division general education requirements. Depending upon the student's major, it may be advantageous to complete the requirements of the specific campus the student plans to attend.

### CALIFORNIA STATE UNIVERSITY GENERAL EDUCATION CERTIFICATION REQUIREMENTS

A maximum of 39 units is required to fulfill the CSU lower division general education requirements, with the units to be distributed as follows: Nine (9) units in Area A; nine (9) units in Areas B, C and D, with no more than 30 units total in areas B through D combined; and three (3) units in Area E.

A letter grade of "C" or higher is required in Oral Communication, Written Communication, Critical Thinking, and Mathematical Concepts.

**Note: Courses appearing in more than one category may be used to satisfy only one category. Such courses are marked with an \*.**

- A) Communications: 9 units minimum.  
Must take one course from category 1, 2, and 3
  - 1. Oral Communication  
Communication Studies 100, 120, 125, 130, 132
  - 2. Written Communication  
English 100, 100S
  - 3. Critical Thinking  
Communication Studies 103  
English 103, 110  
Philosophy 103, 106  
Psychology 103  
Reading 103
  
- B) Natural Science and Mathematics: 9 units minimum.  
Take a course from category 1, 2 and 3. AT LEAST ONE LABORATORY (LAB) MUST BE INCLUDED IN CATEGORY 1 or CATEGORY 2.
  - 1. Physical Sciences  
Astronomy 102, 103, 104, 105L (lab), 106  
Chemistry 100 (lab), 110 (lab), 111 (lab), 112 (lab)  
Earth Science 101, 102 (lab), 104, 104L (lab), 106, 110 (lab)  
Energy 100  
Geography 101, 101L (lab), 103  
Geology 101 (lab), 102, 102L (lab), 103, 103L (lab), 201 (lab), 204, 207 (lab), 208, 209  
Physical Science 100, 112 (not considered a LAB science for CSU GE)  
Physics 100 (lab), 101 (lab), 102 (lab), 201 (lab), 202 (lab), 203 (lab)
  - 2. Biological Sciences  
Anatomy and Physiology 120 (lab), 150 (lab), 151 (lab), 200 (lab), 201 (lab)  
Anthropology 115, 115L (lab)  
Biology 105, 110 (lab), 115 (lab), 120 (lab), 200 (lab), 201 (lab), 202  
Botany 120 (lab)  
Microbiology 200 (lab)  
Psychology 241  
Zoology 120 (lab)
  - 3. Mathematical Concepts  
+ Finance 125M (see important footnote on page 125)  
Mathematics 110A, 110B, 112, 114, 115, 116, 140, 155, 160, 170, 190, 225, 250  
Psychology 210
  
- C) Fine Arts and Humanities: 9 units minimum.  
Take one course in category 1 and 2. The third course may be taken in either category
  - 1. Fine Arts  
Architecture 112  
Art 100, 101, 102, 103, 104, 105A, 105B, 106, 107, \*108, \*109, 110, 113, 116, 118, 120, 130A, 150, 193  
Dance 100, 101  
Film 159  
Humanities \*108, \*109  
Music 100, 101, 102, 103, 104, 104B, 105, 180  
Photography 100, 160

# GENERAL EDUCATION REQUIREMENTS FOR THE ASSOCIATE DEGREE AND FOR TRANSFER TO THE CALIFORNIA STATE UNIVERSITY

Theatre 101, 102, 103, 104, 150, RTV/TH 151, RTV 152  
Women's and Gender Studies 118

## 2. Humanities

American Sign Language 110, 111, 210, 211, \*220  
Art \*108, \*109, 124, 125, 207  
Chinese 101, 102, 201, 202, 260  
Communication Studies 140  
English 102, 106, 221A, 221B, 222, 223, 224, 225, 226, 227, 228,  
230A, 230B, 231, 232, 233, 234, 235, 236, 237, 238, 239, 245,  
246A, 246B, 248A, 248B, 249  
French 101, 102, 201, 202, 203, 281, 282, 283, 285  
German 101, 102, 201, 202  
History \*101, \*102, \*103, \*110, \*120, \*210, \*220, \*221, \*230,  
\*235, \*241, \*242, \*245, \*246, \*250, \*255, \*260, \*265, \*275  
Humanities 100, \*108, \*109, 125  
Japanese 101, 102, 201, 202  
Philosophy 100, 102, 104, 105, 107, 108, 109, 130, 140, 200, 201,  
203, 204, 205, 206  
Photography 150  
Political Science \*240  
Spanish 101, 102, 111, 112, 201, 202, 210, 245, 260, 285  
Women's and Gender Studies 102, 109, 207

## D) Social Sciences: 9 units minimum.

Take one course in category 1, 2 and 3.

### 1. American History

History \*101, \*102, \*103  
(Any one of these courses meet the requirement in U.S.  
History)

### 2. American Government

Political Science 101, 201  
(Either of these courses meet the requirement for Constitution  
and American Ideals)

### 3. Social, Political, Historical and Economic Institutions

Administration of Justice 101  
American Sign Language \*220  
Anthropology 100, 120, 170, 200, 202, 203, \*205, 206  
Business Administration 100  
Child Development \*110  
Communication Studies 110, 115  
Economics 101, 102, 201, 201M, 202, 202M, 204  
Environmental Policy 200  
Geography 102, 105, 140  
History \*110, \*120, 204, \*210, \*220, \*221, \*230, \*235, \*241,  
\*242, \*245, \*246, \*250, \*255, \*260, \*265, \*275  
Humanities 107  
Journalism 100  
Kinesiology \*108, 211  
Political Science 110, 210, 220, 230, \*240, 250, 260  
Psychology 101, \*150, 251, 261, 265, 271, 275  
Sociology 101, \*110, \*120, 201, 202, 205, 210, 215, 230, 250  
Women's and Gender Studies 101, 105, 107, \*108, 115, 140, 202,  
204, \*205, 206, 209, 250

## E) Self-Development: 3 units minimum.

Take one course from the following:

Anthropology \*205  
Child Development \*110  
Counseling 200  
Health Education 100, 101, 103, 105  
Health Occupations 152  
Kinesiology 104, \*108  
Psychology \*150, 245  
Reading 101  
Sociology \*110, \*120  
Women's and Gender Studies 103, \*108, \*205

\* These courses appear in more than one category, but may be used only to satisfy one category.

+ May not be used for any regular (non-AAT/AST) AA degree. Please see a counselor for more information.

**NOTE: Changes in the above General Education requirements may occur from time to time. If courses are added to or deleted from the pattern, this may affect a student's selection of courses. Students do not have catalog rights to a certification pattern, regardless of their continual attendance status.**

CSU Transfer credit is noted in individual catalog course descriptions. A complete list of CSU transferable courses offered by Cerritos College can be found on the ASSIST website at [www.assist.org](http://www.assist.org).

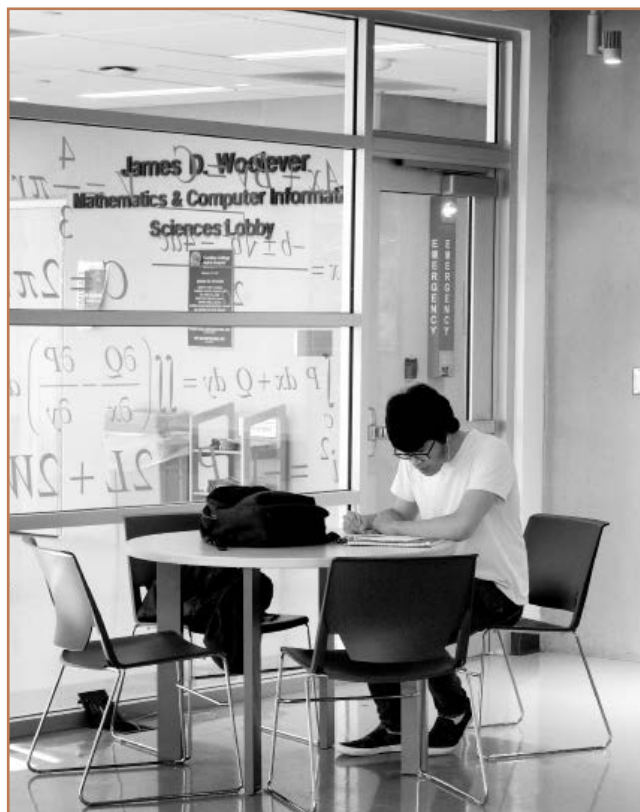

# GENERAL EDUCATION REQUIREMENTS FOR THE ASSOCIATE DEGREE AND FOR TRANSFER TO THE CALIFORNIA STATE UNIVERSITY AND UNIVERSITY OF CALIFORNIA

## Associate in Arts Degree General Education 2020-21 Plan C and/or The Intersegmental General Education Transfer Curriculum (IGETC) For Transfer To UC And CSU

Plan C is designed primarily for students who intend to transfer to the University of California (UC) or are undecided between transferring to the UC or the California State University (CSU). Students may use this plan to combine completion of both the A.A. Degree general education requirements and the IGETC General Education requirements.

The purpose of IGETC is to provide an option for students to fulfill lower division general education requirements prior to transferring to a UC or CSU campus.

Depending upon the student's major and campus choice, it may be advantageous to complete the requirements of the specific campus the student plans to attend. In general, it is not advisable for transfer students preparing for majors at any UC campus requiring a high number of units, such as engineering and science, to use IGETC.

Plan C can be fulfilled by completing the IGETC requirements specified for either the UC or CSU.

### A letter grade of "C" or higher is required in all Plan C courses.

To earn an Associate in Arts degree using Plan C, students must complete a minimum of 60 degree applicable units with a grade point average of "C" (2.0) or higher, which must include the specified general education requirements and designated courses for a major. The Health and Wellness Proficiency requirement must be completed (see description in Plan A).

If a student wishes only to transfer and is not seeking an A.A. degree, they can follow the requirements below. There are no proficiencies required for IGETC certification.

It should be noted that completion of IGETC is not required for admission to the UC or CSU.

Further information and other regulations pertaining to IGETC and the Associate in Arts Degree are found in the catalog.

### AREA 1 ENGLISH COMMUNICATION

CSU: Courses from A, B, and C required.

UC: Courses from A and B required.

- A) English Composition  
(1 course, 3 semester/4-5 quarter units)  
English 100, 100S

- B) Critical Thinking-English Composition  
(1 course, 3 semester/4-5 quarter units)  
Communication Studies 103  
English 103, 110  
Philosophy 103  
Psychology 103  
Reading 103
- C) Oral Communication (CSU ONLY)  
(1 course, 3 semester/4-5 quarter units)  
Communication Studies 100+, 120, 130, 132+

### AREA 2 MATHEMATICAL CONCEPTS AND QUANTITATIVE REASONING

(1 course, 3 semester/4-5 quarter units)  
Mathematics 112+, 114+, 115, 116+, 155+, 160+, 170+, 190, 225,  
250  
Psychology 210+

### AREA 3 ARTS AND HUMANITIES

(3 courses, with at least one from A and one from B below;  
9 semester/12-15 quarter units)

- A) Arts  
Architecture 112  
Art 100, 101, 102, 103, 104, 105A, 105B, 106, 107, \*108, \*109, 113, 118  
Dance 100, 101  
Film 159  
Humanities \*108, \*109  
Music 100, 101, 103, 104, 104B, 105, 180  
Photography 160  
Theatre 101, 102, 103, 104, 150  
Women's and Gender Studies 118
- B) Humanities  
American Sign Language 111, \*220  
Art \*108, \*109, 124, 125, 207  
Chinese 102, 201, 202, 260  
English 102, 106, 221A, 221B, 222, 223, 224, 225, 226, 227, 228,  
230A, 230B, 231, 232, 233, 234, 235, 236, 237, 238, 239, 245, 246A,  
246B, 248A, 248B, 249  
French 201, 202, 281, 282, 283, 285+  
German 102, 201, 202  
History \*101+, \*102+, \*103+, \*110, \*120, \*210+, \*230, \*235,  
\*241, \*242, \*245, \*246, \*250, \*255, \*260, \*265, \*275  
Humanities 100, 107, \*108, \*109, 125  
Japanese 102  
Philosophy 100, 102, 104, 105, 107, 108, 109, 130, 140, 200, 201,  
203, 204, 205, 206  
Photography 150  
Political Science \*240  
Spanish 102+, 112+, 201, 202, 205, 210, 245, 260, 285+  
Women's and Gender Studies 102, 109, 207

# GENERAL EDUCATION REQUIREMENTS FOR THE ASSOCIATE DEGREE AND FOR TRANSFER TO THE CALIFORNIA STATE UNIVERSITY AND UNIVERSITY OF CALIFORNIA

## AREA 4 SOCIAL AND BEHAVIORAL SCIENCES

(3 courses from at least two disciplines or an interdisciplinary sequence: 9 semester/12-15 quarter units)

American Sign Language \*220

Anthropology 100, 120, 170, 200, 202, 203, 205, 206

Child Development 110

Communication Studies 110, 115

Economics 101+, 102, 201, 201M, 202, 202M

Environmental Policy 200

Geography 102, 105, 140

History \*101+, \*102+, \*103+, \*110, \*120, 204, \*210+, \*230,

\*235, \*241, \*242, \*245, \*246, \*250, \*255, \*260, \*265, \*275

Humanities 107

Kinesiology 108

Political Science 101+, 201+, 210, 220, 230, \*240

Psychology 101, 150, 251, 261, 265+, 271

Sociology 101, 110, 120, 201, 202+, 205, 210, 215, 250

Women's and Gender Studies 101, 105, 107, 108, 115, 140, 202+, 204, 205, 206, 209, 250

## AREA 5 PHYSICAL AND BIOLOGICAL SCIENCES

(2 courses, one from A and one from B below; at least one course must include laboratory (lab); 7-9 semester/9-12 quarter units)

### A) Physical Sciences

Astronomy 102+, 103+, 104, 105L (lab) 106

Chemistry 100+ (lab), 110+ (lab), 111 (lab), 112 (lab)

Earth Science 101, 102 (lab), 104, 104L (lab), 106, 110+ (lab)

Geography 101, 101L (lab), 103

Geology 101 (lab), 102, 102L (lab), 103, 103L (lab), 201 (lab), 207 (lab), 208, 209

Physical Science 100+

Physics 100+ (lab), 101+ (lab), 102+ (lab), 201+ (lab), 202+ (lab), 203+ (lab)

### B) Biological/Life Sciences

Anatomy and Physiology 120+ (lab), 150+ (lab), 151+ (lab), 200+ (lab), 201+ (lab)

Anthropology 115, 115L (lab)

Biology 115 (lab), 120+ (lab), 200 (lab), 201 (lab), 202

Botany 120 (lab)

Microbiology 200 (lab)

Psychology 241

Zoology 120 (lab)

\* These courses appear in more than one category, but may be used only to satisfy one category.

## ADDITIONAL REQUIREMENTS

### A) UC ONLY: Language other than English

There are several ways to satisfy this requirement. They include:

- Complete two years of the same foreign language in high school with a grade of "C-" or higher.
- Complete first college course in any foreign language or ASL 110.

c. Earn a minimum score of 500 on an appropriate College Board Achievement Test in a foreign language.

d. For other options, see your counselor.

B) CSU ONLY: The CSU has a specific American Institutions requirement that is separate from the general education requirements. Courses used to meet the American Institutions requirement may be used to satisfy requirements for the IGETC, at the discretion of the receiving CSU campus. It is recommended that this requirement be met prior to transfer. The following will meet the CSU American Institutions requirement.

6 units, one course from Group 1 and one course from Group 2.

Group 1: History 101+, 102+, 103+

Group 2: Political Science 101+, 201+

C) The UC-bound student should be aware of the American history and institutions requirements at the campus of choice. Requirements may vary. See your counselor for details.

+Credit limitation. UC credit limitations may apply for certain courses in IGETC, as well as other UC transferable courses which are not in IGETC. An explanation for each course, which has credit limitations, appears in the college catalog course description. For details, see your counselor.



# SERVICES FOR STUDENTS

*The following pages describe the student services available at Cerritos College. We sincerely hope that you take the time to become familiar with these services and use them often to meet your goals at the college. The telephone extension of each service is listed. The college telephone number is (562) 860-2451.*

## ACCIDENT INSURANCE

EXT. 2321

Accident insurance is provided by Cerritos College to all enrolled students in the event of an accident or injury during college sponsored and supervised activities. The insurance **may** assist in covering medical bills incurred by students and athletes. There are benefit limitations and some exclusions in the policy, so it is important to work with the Student Health Services staff to insure optimum coverage. Students enrolled at Cerritos College, whose children are injured while using the officially designated childcare facility on campus, are covered by Accident Insurance.

## ADMISSIONS AND RECORDS

EXT. 2211

The Admissions and Records Office is responsible for: the application for admission, academic records, transcripts, student academic petitions, enrollment, payment of fees, and student IDs. For additional information, visit our website at [www.cerritos.edu/admissions](http://www.cerritos.edu/admissions).

## ASSESSMENT OFFICE

EXT. 2599

Assessment for Placement or the Self Report Tool (SRT) or Guided Placement Tool (GPT), may be accessed by logging in to the student's MyCerritos account. The links are located on the right side of the screen under "Placement." For those who prefer to complete the SRT or GPT in person, visit the Assessment Center, located on the second floor of the Multipurpose Building, MP 206. Results are used for advisement in selecting classes. In most cases students may place directly into transfer level courses in the areas of math and English/ESL. A current Cerritos College student number and photo ID are required to complete the process. Please visit the website at [www.cerritos.edu/assessment-center](http://www.cerritos.edu/assessment-center) for the current office schedule.

## ATHLETICS

EXT. 2862

Cerritos College is a member of the California Community Colleges Athletic Association (CCCAA). Cerritos men's teams are represented in: baseball, basketball, cross country, football soccer, swimming, tennis, track and field, water polo and wrestling. Cerritos women's teams are represented in: basketball, cross country, soccer, softball, swimming, tennis, track and field, volleyball, and water polo.

## BOOKSTORE

EXT. 2462

The Cerritos College Bookstore is maintained by the Follett Higher Education Group in association with the ASCC. The store carries required materials, new and used textbooks, reference materials, school supplies, snacks, imprinted gifts, and clothing. MasterCard, Visa, American Express, and Discover are accepted.

## CALWORKS

EXT. 2593

The Cerritos College CalWORKs Program assists students who are receiving cash aid assistance through the state of California's CalWORKs Welfare Program, are in good standing with the college, and have developed or are in the process of developing a welfare-to-work plan with the local welfare office. The program provides eligible students with the following support services: Academic, Career, Transfer, and Personal Counseling services; Priority Enrollment; one-on-one new student orientations; Basic Needs Assistance; math tutoring; computer lab; study rooms; workshops; scholarship opportunities; referrals to campus- and community-based organizations; and up-to-date information regarding welfare regulations, rules, and requirements. The staff advocates for students with the Department of Public Social Services (DPSS) in order to ensure that county, state, and federal regulations are administered fairly and correctly. For eligible students, the CalWORKs Office also provides a work-study program, which includes Career Guidance, assistance with resumé writing, mock interviewing skill building, Pre-Employment Preparation workshops (PEP), and subsidized paid work-study placements on campus. To make an appointment with a CalWORKs Counselor, please call (562) 860-2451, ext. 2593. The CalWORKs Office is located in the Santa Barbara Building. Our hours are Monday – Thursday, 8 am – 6:30 pm; and Friday, 8 am – 4:00 pm. For additional information, please visit our website at [www.cerritos.edu/calworks](http://www.cerritos.edu/calworks).

## CAMPUS NEWS SERVICES AND SOCIAL MEDIA

EXT. 2618

To keep you abreast of community news and interesting aspects of campus life, student news outlets are available to you free of charge. Campus news is available daily online on the award-winning Talon Marks website ([talonmarks.com](http://talonmarks.com)) and via a weekly e-newsletter. Sign up for the e-newsletter today on Talon Marks' homepage. Produced by students in the Mass Communications Department, the monthly Talon Marks newspaper also provides timely sports news, opinions, arts and entertainment. For breaking news, podcasts and live interviews, follow Talon Marks on Twitter, Facebook, Spotify and Instagram.

## CAREER PLANNING

EXT. 2356

Career planning is available to individuals who are currently enrolled, who have graduated, or who hold certificates from Cerritos College. Career planning provides opportunities to explore career options, as well as the use of sophisticated computerized search programs including the Internet. Students are encouraged to take advantage of the skills, interests, and values inventories that are available to them in Career Services. A career counselor will assist you with understanding your assessment results and help you in choosing a career or major.

## CAREER SERVICES

EXT. 2356

Career Services offers the following services to assist students in exploring and planning their academic and vocational futures: (1) Assessment Office, ext. 2599; (2) Career Planning, ext. 2356; (3) Student Employment Resources, ext. 2366; and (4) Re-entry Programs, ext. 2362. You may visit our website at [www.cerritos.edu/career-services](http://www.cerritos.edu/career-services) for additional information and our current schedule.

# SERVICES FOR STUDENTS

## CHILD DEVELOPMENT CENTER

EXT. 2583

The Cerritos College Child Development Center Program is open for services to students, college employees, and the community. The Center is also a laboratory school for future teachers in the field of Early Childhood Education. We are committed to providing an outstanding quality program that is welcoming, nurturing, stimulating, creative, and safe for children ages 2 to 5 years old. We are a 5-star Child Development Program inspired by the Reggio Emilia approach to learning. We pride ourselves on building meaningful relationships where the children, families, and community are at the heart of our preschool program. The Child Development Center is open Monday through Friday, from 7:30 am to 5 pm.

Due to the ongoing COVID-19 pandemic, students interested in these services may visit our website to fill out a "Request for Child Development Services Form" or call (562) 78860-2452, ext. 2583

## COUNSELING

(562) 467-5231

Counselors are available in the Counseling Department to assist you with academic advisement, establishing realistic goals and devising a comprehensive student educational plan (C-SEP) to meet those goals. Counselors can keep you abreast of current requirements for your major. Counselors are available in person or virtually for appointments or standby/drop-in for quick questions. Online counseling is available at [www.cerritos.edu/counseling](http://www.cerritos.edu/counseling). Counseling Department hours are Monday through Thursday, 8 am – 7 pm; and Friday, 8 am – 2 pm (excluding summer).

## EXTENDED OPPORTUNITY PROGRAMS AND SERVICES (EOPS)

EXT. 2398

Extended Opportunity Programs and Services (EOPS) assists low-income and educationally disadvantaged students in college. The program offers academic, personal, and career counseling; book grants; tutoring; early enrollment assistance; counseling courses; EOPS Summer Bridge program; school supplies; transfer assistance; and university tours. For more information, call (562) 860-2451, ext. 2398, or visit our website at [www.cerritos.edu/eops](http://www.cerritos.edu/eops).

## FINANCIAL AID OFFICE

EXT. 2397

The Financial Aid Office offers grants, work-study opportunities, loans, and scholarships provided by federal and state governments and local agencies. The Free Application for Federal Student Aid (FAFSA) can be submitted at [www.fafsa.gov](http://www.fafsa.gov), and the California Dream Act application can be submitted at [www.caldreamact.org](http://www.caldreamact.org). The federal school code for Cerritos College is 001161. Financial Aid Office services are available online 24/7 via FATV online videos, MyCerritos, and Ask Franco Chatbot. Financial Aid staff are available to communicate online Monday through Thursday, 8 am – 7 pm; and Friday, 8 am – 2 pm. For additional information, visit our website at [www.cerritos.edu/finaid](http://www.cerritos.edu/finaid) or email us at [finaid@cerritos.edu](mailto:finaid@cerritos.edu).

## HEALTH INSURANCE

EXT. 2321

Supplemental insurance coverage programs are available for health and hospitalization coverage. Students interested should contact Student Health Services for insurance referrals.

## HEALTH SERVICES

EXT. 2321

Health services are available to all students currently enrolled at Cerritos College upon proof of enrollment. First aid and referrals are available to all faculty, staff, and visitors. The Student Health Services is staffed by a group of professionals which include physicians, nurse practitioners, registered nurses, psychologists, medical assistants, and clerical support. They are all dedicated to your health and wellness. The SHS is able to provide basic outpatient services for the diagnosis and treatment of acute and sub-acute illnesses and injuries. A brief overview of services includes urgent care, preventive care, women's and men's health care; as well as, chiropractic services, referrals to psychological and optometric services, and a variety of support services (pharmacy, laboratory, health education, etc.). Accident, International student, and supplemental insurances are also available through the SHS. Office hours are currently Monday through Thursday, 8 am – 4:00 pm; and Friday, 8 am – 2 pm. We invite you to visit our website at [www.cerritos.edu/shs](http://www.cerritos.edu/shs), or call (562) 860-2451, ext. 2321. We are located on the southeast corner of campus and would like to extend an invitation for you to stop in and visit.

## LEADERS INVOLVED IN CREATING CHANGE (LINC)

EXT. 2371

Leaders INvolved in Creating Change (LINC) is a support program designed to help link foster youth with support services on and off campus to ensure a successful transition from foster care to independent living. The goals of the program are to improve college access for current and former foster youth, increase retention and graduation rates, and promote student learning and development. Services provided to LINC students include academic counseling, early enrollment assistance (if eligible), tutoring, assistance with financial aid, and links to on-campus and off-campus resources. For more information call (562) 860-2451, ext. 2371, or visit [www.cerritos.edu/linc](http://www.cerritos.edu/linc).

## LIBRARY AND LEARNING RESOURCE CENTER

EXT. 2430

While the College is offering classes and services remotely due to the COVID-19 virus, the Wilford Michael Library will continue to provide access to thousands of online books, articles, research guides, and streaming videos. Reference service is provided by librarians via chat, Zoom, and email. To access these services and see the current library chat hours, please visit the library website at <https://www.cerritos.edu/library>.

Online resources are available 24 hours every day. Current students may access all these resources with their student ID number and their eight-digit birthday (MMDDYYYY).

## MENTAL WELLNESS PROGRAM

EXT. 2321

Psychological services, crisis intervention, and referrals are available to students experiencing emotional difficulties or concerns. Please contact Student Health Services at extension 2321 for assistance, or visit our website at [www.cerritos.edu/shs](http://www.cerritos.edu/shs).



# SERVICES FOR STUDENTS

## OFFICE OF INTERNATIONAL STUDENT SERVICES EXT.2133

The Office of International Student Services (OISS) fosters the education and development of F-1 Nonimmigrant students. The program provides eligible students with a comprehensive "One-Stop" approach with the following services: Admissions, Academic Counseling and Advising, early enrollment, small group orientations, welcome receptions advocacy regarding immigration requirements, computer lab, study rooms, and on-campus and community resources. The well-trained staff provides a welcoming and nurturing environment that assist new and continuing students to stay in federal program compliance and maintain good academic standing. The program provides workshops and support that assist students in adjusting to the American Culture and the California Community College educational system.

Cerritos College also offers a full-time Intensive English Program (IEP) to help develop English language skills. The IEP is a student-centered environment where students are fully immersed into the English language and culture. Upon successful completion, students can transition into their major field of study at Cerritos College and then transfer to the university of their choice.

To view the application for the *Academic* and/or *Intensive English Program* and **ALL** required documents, please visit our site at [www.cerritos.edu/international](http://www.cerritos.edu/international), or call us at (562) 860-2451, ext. 2133. Our email address is [oiss@cerritos.edu](mailto:oiss@cerritos.edu).

## PARKING EXT. 2325

On-campus student parking for vehicles will be free. There will be no cost for student parking during the Fall semester 2020, between the hours of 6 am and 10 pm. Students parking in white student stalls will not require a parking permit. All other parking violations will be strictly enforced (i.e. Student's parking in staff stalls, handicapped and fire zone violations). Vehicles with a valid disabled "DP" placard or plate and a current and valid student or one-day permit are permitted to park in staff parking lots. "Blue Curb" and marked disabled parking stalls do not require a parking permit if a valid "DP" placard or plate is displayed in the vehicle (the registered owner of the "DP" placard must be present at all times when placard is being used on campus). Persons displaying a "DP" plate or placard may not park in parking stalls reserved for "Carpool" or "Board Members" at any time. Student parking is free the first week of each semester in any white-lined parking stall.

**VEHICLES WITHOUT A PERMIT OR THAT ARE INCORRECTLY PARKED CAN BE ISSUED A PARKING CITATION. CERRITOS COLLEGE ASSUMES NO LIABILITY AND IS NOT RESPONSIBLE FOR DAMAGE TO OR THEFT OF ANY VEHICLE OR ITS CONTENTS. LOST OR STOLEN PARKING PERMITS ARE NOT REPLACED. PLEASE REFER TO THE COLLEGE CATALOG FOR ADDITIONAL PARKING INFORMATION.**

## RE-ENTRY RESOURCE PROGRAM EXT. 2362

The Re-entry Resource Program assists adults returning to school make a smooth transition, overcome barriers unique to returning adults, and successfully attain their college goals and objectives. Services include personal assistance, orientations, workshops based on re-entry student issues, support groups, information regarding child care, financial aid, career counseling, job placement, scholarship information, and community resources. The program also coordinates the annual Major's Exploration and Community Resources Fair. Re-entry students of varied ages find these services relevant to their needs and interests. The Re-entry Resource Program is located in Career Services. For more information, visit us at [www.cerritos.edu/re-entry-program](http://www.cerritos.edu/re-entry-program).

## STUDENT ACCESSIBILITY SERVICES (SAS) EXT. 2335 (formerly Disabled Student Programs and Services) (DSPS)

Students with educational limitations due to a disability may receive accommodations and services from Student Accessibility Services (SAS). SAS serves students with disabilities such as mobility, vision loss, hearing

loss, mental health, learning, autism, and other health-related disabilities. SAS has been in operation at Cerritos College since 1969. For more information or to schedule an appointment call (562) 860-2451, ext. 2335; (562) 274-7164 (VP); or visit our website at [www.cerritos.edu/sas](http://www.cerritos.edu/sas).

## STUDENT EMPLOYMENT RESOURCES EXT. 2366

Cerritos College students and alumni who are seeking employment may review job listings in Career Services. Additional listings are accessible through the Internet. Assistance in seeking internships is also provided. Handouts on job search resources, resumé writing, and interviewing skills are available on request. Student Employment coordinates the bi-annual job fairs, Employer Business Panel, and on-campus employer information tables. For more information, call (562) 860-2451, ext. 2366; email [student-employment@cerritos.edu](mailto:student-employment@cerritos.edu); or visit us at [www.cerritos.edu/job-placement](http://www.cerritos.edu/job-placement).

## SUCCESS CENTER EXT. 2855

The Success Center has been established to serve the needs of faculty and students across the campus. The Success Center provides learning assistance and academic support for students at all levels. Assistance in virtually any subject is available via online tutoring and workshops with qualified tutors and instructors. Faculty and staff in the Success Center involve instructors to develop supplemental instruction in a variety of forms and work with instructors to enhance course offerings. For hours, special schedules, and additional information; please visit the Center's website at [www.cerritos.edu/sc](http://www.cerritos.edu/sc).

## TRANSCRIPTS/VERIFICATION OF ENROLLMENT EXT. 2211

A transcript of all college work completed may be obtained by submitting a written request in the Admissions and Records Office. If ordered on campus, the first 2 transcripts (whether official or unofficial) and verifications of enrollment are free. For subsequent copies, a fee of \$3 is charged for each regular transcript; a \$10 fee is charged for each rush transcript requested at least 2 hours before closing. The fee for verification of enrollment is \$2 for three to five working days processing time, or \$7 for 24-hour service. Please contact the Admissions and Records Office by phone or check the website at [www.cerritos.edu/](http://www.cerritos.edu/), "MyCerritos", "Transcripts", for information on ordering transcripts via the web.

## TRANSFER CENTER EXT. 2154

The Transfer Center offers information, referrals, and counseling services. The Transfer Center provides transfer events and workshops, general education information, advising appointments with university representatives, and university tours. Visit our website at [www.cerritos.edu/transfer](http://www.cerritos.edu/transfer) for our current schedule.

## VETERANS' EDUCATION OFFICE EXT. 3716

The Veterans' Education Office is located in the Veterans' Resource Center. The primary function of this office is to certify to the Veteran's Administration that eligible veterans are enrolled at the college and pursuing an approved educational goal. Visit our website at [www.cerritos.edu/va](http://www.cerritos.edu/va) for our current schedule.

## VETERANS' RESOURCE CENTER EXT. 3716

The Veterans' Resource Center (VRC) is a one-stop center that houses certifying officials, veteran's counselors, tutors, and other valuable resources. There are computers available for veteran students' use and assistive technology for improved learning. Tutoring is available Monday through Wednesday, 8 am – 7 pm; and Thursday, 8 am – 5:30 pm. The VRC is located in the Student Center Complex.

# SERVICIOS PARA ESTUDIANTES

## ADMISIONES Y REGISTRO

EXT. 2211

La oficina de Admisiones y Registro tiene muchas funciones. Es responsable por: solicitud de admisión, registros permanentes, peticiones de transcripción, peticiones académicas, verificación de matriculación de estudiantes para las instituciones pertinentes, y un segmento de el procedimiento de matriculación. Preguntas y comentarios pueden ser dirigidos al Decano de Admisiones y Servicios de Registro. Salvo en el tiempo de inscripción, el horario de la Oficina de Admisiones y Registro es Lunes a Jueves, 8 am – 7 pm; Viernes, 8 am – 2 pm. Para obtener información adicional, visite nuestro sitio de web en [www.cerritos.edu/admissions](http://www.cerritos.edu/admissions).

## OFICINA DE EVALUACIONES/COLOCACION EXT. 2599

La Evaluación para ubicación o la Herramienta de auto evaluación (SRT) son administradas en la Oficina de Evaluaciones que se encuentra en el segundo nivel del Edificio de usos múltiples. Los resultados se utilizan para la orientación en la selección de clases. Para los estudiantes que se graduaron de la escuela secundaria en los últimos 10 años, las certificaciones de una escuela secundaria de Estados Unidos se utilizan para ubicarlos en las clases de Lectura, Matemáticas o ESL. Los estudiantes que se graduaron de la escuela secundaria hace más de 10 años, que no hicieron o no completaron la escuela secundaria o que no tienen certificaciones de una escuela secundaria de Estados Unidos deben comunicarse con la Oficina de Evaluaciones para obtener las opciones apropiadas. Visite nuestro sitio web en [www.cerritos.edu/assessment-center](http://www.cerritos.edu/assessment-center) para ver el programa de Evaluaciones vigente.

## LIBRERIA

EXT. 2462

La librería de Cerritos College es operada por el Grupo Follet Higher Education, en asociación con la ASCC. La tienda brinda materiales necesarios, libros nuevos y usados, materiales de referencia, útiles escolares, bocadillos, regalos y ropa impresa. Mastercard, Visa, American Express y Discover son aceptados. Las horas regulares de Otoño y Primavera son: 7:30 am a 7 pm, de Junes a Jueves; 7:30 am a 2 pm, Viernes; cerrado Sábados y Domingos.

## CONSEJERIA

(562) 467-5231

Los consejeros están disponibles en el Departamento de Asesoramiento para ayudarle con asesoría académica, el establecimiento de metas realistas y la elaboración de un integral plan de educación para alcanzar esos objetivos. Consejeros pueden mantenerle al corriente de las necesidades actuales de su carrera. Los consejeros están disponibles por medio de citas de media hora o limitadamente sin cita para breves consultas. Consejería en línea está disponible en [www.cerritos.edu/counseling](http://www.cerritos.edu/counseling). Los horarios del Centro de asesoría son Lunes a Jueves de 8 am a 7 pm; y el Viernes de 8 am a 2 pm (excluyendo verano).

## SERVICIOS DE ACCESIBILIDAD ESTUDIANTIL (SAS) EXT. 2335

Los estudiantes con limitaciones educativas debido a una discapacidad pueden recibir adaptaciones y servicios de los servicios de accesibilidad estudiantes (SAS). SAS atiende a estudiantes con discapacidades como movilidad, visuales, pérdida de la audición, psicológicas, del aprendizaje, autismo y otras discapacidades relacionadas con la salud. SAS ha estado funcionando en Cerritos College desde 1969. Para obtener más información o para programar una cita llame al (562) 860-2451, ext. 2335; (562) 274-7164 (VP); o visite nuestro sitio web en [www.cerritos.edu/dsps](http://www.cerritos.edu/dsps).

## OFICINA DE AYUDA FINANCIERA

EXT. 2397

La Oficina de Ayuda Financiera ofrece becas, trabajo y oportunidades de estudio, préstamos y becas otorgadas por los gobiernos federales y estatales y agencias locales. La Solicitud Gratuita de Ayuda Federal para Estudiantes (FAFSA) puede llenarse en la web en [www.fafsa.gov](http://www.fafsa.gov) y la solicitud de California Dream Act se puede enviar a [www.caldreamact.org](http://www.caldreamact.org). El código de Cerritos College es 001161. El horario de la Oficina de Ayuda Financiera es Lunes a Jueves, 8 am – 7 pm; Viernes, 8 am – 2 pm. Para obtener información adicional, visite nuestro sitio web en [www.cerritos.edu/finaid](http://www.cerritos.edu/finaid).

## ESTACIONAMIENTO

EXT. 2325

El estacionamiento en Cerritos College es únicamente con permiso. Las regulaciones de estacionamiento se deben cumplir las 24 horas del día, los 7 días de la semana. Se puede solicitar un permiso de estacionamiento semestral por Internet. Para hacerlo, regístrese en MyCerritos en y haga clic en el enlace “Buy Parking Permit” (Comprar permiso de estacionamiento). También se pueden comprar permisos en el campus, en la Oficina de Admisiones y Registros (Admissions and Records Office) durante el horario normal de atención, y en la Policía del Campus (Campus Police) cuando la Oficina de Admisiones y Registros esté cerrada, incluso los fines de semana. Se pueden comprar permisos por día, por \$2, en los dispensadores de boletos ubicados en nuestros estacionamientos para estudiantes. Todas las expendedoras de permisos aceptan billetes de dólar y monedas, pero no dan cambio ni reembolsos de ningún tipo. Todas las máquinas de permisos además aceptan tarjetas de crédito con una tarifa de 25 centavos por el servicio que se suma a cada transacción. Los dispensadores se encuentran cerca de la marquesina frente al gimnasio, en Falcon Way, y en los estacionamientos para estudiantes 1, 5, 6, 8 y 10. Los lugares de estacionamiento por tiempo también se encuentran disponibles en los estacionamientos 2, 6 y 8. Estos lugares requieren del pago y de la exhibición del permiso que es válido por hasta 2 horas. El estacionamiento en lugares reservados para el personal requiere un permiso vigente. Se permite que los vehículos con un cartel o una placa válida por discapacidad “DP” (persona discapacitada, por sus siglas en inglés), y un permiso por un día vigente y válido para estudiantes, estacionen en estacionamientos para el personal. La “acera de color azul” y los lugares de estacionamiento marcados para discapacitados no requieren un permiso de estacionamiento, si el vehículo tiene un cartel o una placa válida de “DP” (el dueño registrado del cartel de “DP” debe estar presente en todo momento cuando se use el cartel en el campus). Las personas que exhiban una placa o un cartel de “DP” no pueden estacionar en ningún momento en aquellos lugares de estacionamiento reservados para “personas que comparten el vehículo” o “miembros de la junta”. El estacionamiento para alumnos es gratuito durante la primera semana de cada semestre en cualquier espacio de estacionamiento marcado con líneas blancas. Tenga en cuenta que el semestre de verano tiene 2 sesiones y que el estacionamiento es gratuito únicamente durante la primera semana de la primera sesión.

SE PUEDE EMITIR UNA CITACIÓN DE ESTACIONAMIENTO A AQUELLOS VEHÍCULOS SIN UN PERMISO O QUE ESTÉN ESTACIONADOS DE FORMA INCORRECTA. CERRITOS COLLEGE NO ASUME NINGUNA RESPONSABILIDAD NI TAMPOCO ES RESPONSABLE DEL DAÑO O ROBO DE NINGÚN VEHÍCULO NI SUS CONTENIDOS. NO SE REEMPLAZAN LOS PERMISOS DE ESTACIONAMIENTO PERDIDOS O ROBADOS. CONSULTE EL CATÁLOGO DE LA UNIVERSIDAD SI DESEA OBTENER INFORMACIÓN

If you have questions or need information in Spanish about Cerritos College, please contact the Admissions and Records Office at [admissions-info@cerritos.edu](mailto:admissions-info@cerritos.edu). Additional information is available in Spanish on pages 10-14.

Si usted tiene preguntas o necesita información en español acerca del Colegio de Cerritos, llame por favor a la Oficina de Admisiones y Registro a [admissions-info@cerritos.edu](mailto:admissions-info@cerritos.edu). Información adicional está disponible en español en las páginas 10-14.

# STUDENT ACCESSIBILITY SERVICES

## FORMERLY DISABLED STUDENT PROGRAMS AND SERVICES

Students with educational limitations due to a disability may receive accommodations and services from Student Accessibility Services (SAS). SAS serves students with disabilities such as mobility, vision loss, hearing loss, mental health, learning, autism, and other health-related disabilities. Students who wish to apply for SAS services should come to the Liberal Arts/DSPS building to pick up a New Student Application. For further information, contact SAS at (562) 860-2451, ext. 2335; (562) 274-7164 (VP); or visit our website at <https://www.cerritos.edu/sas>.

### SAS Services:

SAS determines reasonable accommodations on a case by case basis by reviewing the disability verification documentation and engaging in an interactive process with each student. Following are some of the supportive services which may be approved as reasonable accommodations, depending on the nature of the student's educational limitations, to assure access to educational activities at Cerritos College:

- *Notetakers*
- *Testing accommodations*
- *Materials in alternate format*
- *Assistive Technology*
- *Sign language interpreters*
- *Assistive listening devices*
- *Priority enrollment*
- *Academic adjustments*

### Additional services available through SAS may include:

- *Counseling*
- *Enrollment assistance*
- *Illness notification*
- *Instructor liaison*
- *Assistive technology training*

### Instructional Offerings:

#### Access Learning Courses

ACLR 86 – Introduction to Universal Design for Learning – 2.0 units

ACLR 87 – Using Scan-Read Technologies in Universal Design for Learning – 2.0 units

ACLR 91 – Career Exploration for Students with Disabilities – 1.0 unit

ACLR 101 – Increasing Your Access Potential – 2.0 units

#### Adapted Physical Education Courses

PEX 100 – Fitness for Students with Disabilities – 1.0 unit

PEX 100A – Adapted Independent Exercise – 1.0 unit

PEX 101 – Wheelchair Activities – 1.0 unit

PEX 102 – Adapted Cardiovascular Exercise – 1.0 unit

PEX 103 – Adapted Strength Training – 1.0 unit

PEX 130 A – Adapted Circuit Weight Training – 1.0 unit

PEX 104 – Adapted Stretching and Relaxation – 1.0 unit

PEX 105 – Adapted Swimming – 1.0 unit

PEX 106 – Adapted Aquatic Exercise – 1.0 unit

PEX 106A – Adapted Aquatic Group Fitness – 1.0 unit

PEX 107 – Adapted Team Sports – 1.0 unit

PEX 107A – Adapted Soccer – 1.0 unit

PEX 108 – Adapted Individual Sports – 1.0 unit

PEX 109 – Adapted Group Fitness – 1.0 unit

DANC 102 – Introduction to Adaptive Dance – 2.0 units



Student Accessibility Services is located in the Liberal Arts/DSPS Building.

In accordance with the Americans with Disabilities Act, this information is available in alternate formats (Braille, enlarged type, e-text, etc.) and may be requested by emailing April Shin at [ayshin@cerritos.edu](mailto:ayshin@cerritos.edu).

# SUCCESS CENTER

Do you need tutoring for any of your Cerritos College courses? Do you need help managing your time efficiently? Do you need to learn how to take good lecture notes or learn how to better study from your textbook? Do you need help dealing with the stress of going to college? The Success Center can provide the answers and the help that you're looking for. All Cerritos College students may attend any of the free services listed below. Visit the Success Center's website at [www.cerritos.edu/sc](http://www.cerritos.edu/sc) for more information.

## Individualized Instruction from Faculty

Faculty members are available at various times for assistance in math, English, English as a Second Language, and reading.

## Tutorial Services

Smarthinking Online Tutoring available 24/7.  
Group tutoring with embedded tutors.  
Tutoring by appointment.

## Workshops

Workshops in various topics such as, How to Read Your Textbook, How to Take Great Notes, Stress Management, Student Success, and many more!



# STUDENT SERVICES AND POLICIES

## ASSOCIATED STUDENTS

The Associated Students of Cerritos College (ASCC) provides the governing body that finances, organizes, and directs many programs for the student population. It co-sponsors with the district such activities as touchtone registration, athletics, choir, band, forensics, drama, and the student newspaper. Students are encouraged to participate in campus clubs and organizations. The club program is an ever-growing phase of campus life, with new clubs forming every year. With more than 60 clubs, students are provided the opportunity to become involved in curricular, special interest, and social programs. The Inter-Club Council meets regularly to give all clubs and organizations the chance to share their activities collectively. For additional information about the ASCC and campus clubs, please visit our website at [www.cerritos.edu/activities/student-government/default.htm](http://www.cerritos.edu/activities/student-government/default.htm).

## STATEMENT OF STUDENT RIGHTS AND RESPONSIBILITIES PREAMBLE

The community college exists for the transmission of knowledge, the pursuit of truth, the development of students, and the general well-being of society. Free inquiry and free expression are indispensable to the attainment of these goals. As members of the academic community, students should be encouraged to develop the capacity for critical judgment and to engage in a sustained and independent search for truth and knowledge.

Freedom to teach and freedom to learn are inseparable facets of academic freedom. The freedom to learn depends upon appropriate opportunities and conditions in the classroom, on the campus, and in the larger community. Students should exercise their freedom with responsibility so as not to endanger the rights, goals, and beliefs of other students.

Cerritos College is open to all qualified students regardless of national origin, religion, age, gender, gender identity, gender expression, race or ethnicity, color, medical condition, genetic information, ancestry, sexual orientation, marital status, physical or mental disability, pregnancy, or because he or she is perceived to have one or more of the foregoing characteristics, or based on association with a person or group with one or more of these actual or perceived characteristics, or any other status protected by law in person or in an online environment and, when the victim or victims are associated with the District, whether or not the location is associated with the District.

## CLASSROOM RIGHTS AND RESPONSIBILITIES

The professor in the classroom and in conference should permit free discussion, inquiry, and expression of thought by the student. Student performance should be evaluated solely on an academic basis, not on opinions or willingness to accept professors' personal beliefs, or conduct unrelated to academic standards. Students should be free to take reasoned exception to the data or views offered in any course of study for which they are enrolled and for maintaining standards of academic performance established for each course in which they are enrolled. The student has the right to have the course taught in a systematic, meaningful manner and to know at the beginning of the course those academic standards required of the student in the course.

Administrative staff and faculty members should respect confidential information about students, such as student views, beliefs, and political associations, that is acquired in the course of their work. Transcripts of academic records should contain only information about academic status.

## ON THE CAMPUS RIGHTS AND RESPONSIBILITIES

Students should be free to examine and discuss all questions of interest to them, and express opinions publicly and privately. They should be

free to organize and join associations to promote their common interests. The membership, policies, and actions of a student organization will be determined by vote of only those persons who hold bona fide membership in that college organization. Campus advisors shall advise organizations in the exercise of their rights and responsibilities.

Student organizations shall be required to submit a statement of purpose, criteria for membership, rules of procedures, a current list of officers, and the advisor shall certify the list of verified members. Campus organizations should be open to all students.

Students and student organizations should be free to support causes by orderly means which do not disrupt the regular and essential operation of the college. Student organizations shall have the right to recommend, invite, and hear any person of their own choosing as long as such speakers and topics are in accordance with federal, state, and local laws, and guarantee the safety of students and protection of public property. Guest speakers invited by students or student organizations should be subjected only to those policies, requirements, and regulations as established by the Board of Trustees in order to insure an appropriate and meaningful contribution to the academic community. It should be made clear to the academic community and the larger community that the public expressions of students, student organizations, and guest speakers speak only for themselves.

As constituents of the academic community, students should be free, individually and collectively, to express their views on issues of institutional policy, instruction, the evaluation of professors as it pertains to their course content, and on matters of general interest to the student body.

## IN THE LARGER COMMUNITY

College students are both citizens and members of the academic community. As citizens, students should enjoy the same freedom of speech, peaceful assembly, and right of petition that other citizens enjoy. As citizens, they should be subject to civil law as others and may incur penalties prescribed by civil authorities when violating these laws. Only where the college's interest as an academic community are distinct and clearly involved should the special authority of the college be asserted.

## STUDENT PUBLICATIONS

Student publications and the student press perform the traditional roles of informing, entertaining, and influencing. They are both instructional and informational, and as such should meet the highest academic and professional standards in serving the broad college community and should set forth as the primary goal of the student newspaper the coverage of news events, happenings, and experiences on the college campus.

Associated Student Body, administrative and academic authorities, in consultation with students and advisors have the responsibility to define and clarify the role of student publications, and the standards to be used in their evaluation.

They must also assure that both academic freedom and editorial freedom are protected and exercised so that the integrity of the student publications program and the free press will not be compromised.

It is incumbent upon student editors and managers to act according to the highest ethics of responsible journalism. This corollary responsibility includes careful adherence to the laws of libel and good taste, and such considerations as the avoidance of indecency, undocumented allegations, attacks on personal integrity, and the techniques of harassment and innuendo, and should allow adequate space for rebuttal and differing views in regard to articles in which there is some controversy.

# STUDENT SERVICES AND POLICIES

Safeguards to assure freedom of the student press with responsibility should include freedom from censorship or arbitrary control of the press, and protection of editors and managers from arbitrary attack, suspension, or removal because of disapproval of editorial policy or content by any external influence.

## STUDENT RIGHTS AND GRIEVANCES

Note: Complaints under Section 504, Section 508, and/or the Americans with Disabilities Act are to be made to the Section 504/508/ADA Coordinator in the Disabled Student Programs and Services Office or to the Diversity/Compliance/Title IX Officer in the Human Resources Office. Complaints of sexual harassment and other illegal discrimination are to be made to the Diversity/Compliance/Title IX Officer in the Human Resources Office or the Vice President of Human Resources.

If a student files a grievance under this procedure that includes an allegation of unlawful discrimination, including harassment or retaliation, the grievance, or portion of the grievance, will immediately be referred to: (i) the Diversity/Compliance/Title IX Officer or to the Vice President of Human Resources or designee per AP 3435, "Intake and Processing of the Complaint"; or to (ii) the Cerritos College Section 504/ADA Coordinator per Administrative Procedure 3412, for attempted informal resolution or investigation.

## STUDENT GRIEVANCE PROCEDURES

A student of the College may address grievances as applied to and regarding academic, administrative, and instructional matters relating to students, and including, but not limited to, any grievance dealing with any academic or management employee of the District.

A grievance shall herein be defined as any act depriving a student of any of the rights set forth in the statement of "Student Rights and Responsibilities," or any state, federal, or local codes. Grades and grading grievances are not addressed within this administrative procedure. The student should refer to "Student Grade Grievance Procedure."

The determination of whether the Statement of Grievance presents sufficient grounds for a hearing shall be based on the following:

- The statement contains facts which, if true, would constitute a grievance under these procedures;
- The grievant is a student, which includes applicants and former students;
- The grievant is personally and directly affected by the alleged grievance;
- The grievance was filed in a timely manner;
- The grievance is not clearly frivolous, clearly without foundation, or clearly filed for purposes of harassment.

If the grievance does not meet each of the requirements, the Office of Student Conduct and Grievance or ASCC Chief Justice or designee shall notify the student in writing of the rejection of the request for a grievance hearing, together with the specific reasons for the rejection and the procedures for appeal.

## GRIEVANCE PROCEDURE (EXCEPT GRADES AND GRADING, SEXUAL HARASSMENT, AND OTHER ILLEGAL DISCRIMINATION):

### STEP I - INFORMAL ACTION

- A. The student with a grievance shall first attempt to resolve the matter by informal discussion with the employee(s) involved.
- B. If the problem is not resolved in step I-A, the student shall then attempt to resolve the matter by informal discussion with

the person at the lowest level of supervisory authority for the person with whom there is a complaint.

- C. If the grievant still believes the issue has not been resolved satisfactorily after Step I-B, a student Statement of Grievance Form may be obtained from the Office of Student Conduct and Grievance. After completion of the Form specifying the time, place, nature of the complaint, and remedy or correction requested; it should be submitted to the Coordinator of Student Conduct and Grievance who will send a copy of the written statement to the ASCC Supreme Court Chief Justice and the Vice President of Academic Affairs. This statement must be submitted within 30 instructional days after the grievant has become aware of the act or condition on which the complaint is based. An instructional day is defined as any day Monday through Friday that all normal college business is conducted, both in the classroom and administrative offices. All weekend days and college holidays are excluded.
- D. The ASCC Chief Justice or Court designee shall attempt to resolve the problem through informal meeting and discussion among the pertinent parties while remaining neutral on all issues involved. This informal meeting and discussion is intended to include the levels of management or administration concerned with the problem and should be completed within ten instructional days, as such days are defined herein. In the event the informal procedure fails, the formal procedure may be implemented.

### STEP II - FORMAL ACTION

#### A. PRELIMINARY STEPS

1. If the grievant does not believe the grievance has been resolved, the grievant may request Step II-Formal Action through the ASCC Chief Justice. The Chief Justice upon receiving the request of the grievant shall call a meeting of the Student Grievance Hearing Committee. The Hearing Committee will be composed in the following manner:
  - ASCC Chief Justice or designee and two Court Justices or designees,
  - the Vice President of Academic Affairs or administrative designee,
  - the Faculty Senate President or Senate designee, and
  - one Faculty Senate member, chosen by the Faculty Senate.

If replaced per section II.A.5. herein, the ASCC Chief Justice or designee or Court Justices or designees substitute(s) shall be appointed by the ASCC Court.

2. The Chief Justice or designee shall serve as the Hearing Committee Chair, but shall have no vote in committee decisions. The five voting members of the Hearing Committee may be selected within the first six weeks of the academic year. Names selected by the Faculty Senate are to be submitted to the Chief Justice. Members of the Committee are to serve for an academic year.
3. The Vice President of Academic Affairs or administrative designee shall serve as Hearing Committee Executive Secretary. The Executive Secretary, a voting member of the committee, shall be responsible for keeping necessary records of committee hearings and assist the ASCC Chief Justice in the conduct of the hearing.
4. Grievance Committee members are to deal with all grievances in a confidential manner, except when both parties agree to a public hearing or otherwise required by law.

## STUDENT SERVICES AND POLICIES

5. No person shall serve as a member of a Hearing Committee if that person has been personally involved in any matter giving rise to the grievance, has made any statement on the matters at issue, or could otherwise not act in a neutral manner. Any party to the grievance may challenge for cause any member of the hearing committee prior to the beginning of the hearing by addressing a challenge to the Hearing Committee Chair, who shall determine whether cause for disqualification has been shown. If the Hearing Committee Chair determines that sufficient grounds for removal of a member of the committee have been presented, the Hearing Committee Chair shall remove the challenged member or members and request a substitute from the original appointing constituent group.
- B. FORMAL HEARING
- The Hearing Committee shall conduct its proceedings according to the following procedures:
1. The Hearing Committee must meet within 15 instructional days after informal action has been completed and the grievant has requested a formal hearing.
  2. The Chair must notify the parties involved within five instructional days before the hearing of the date, time, and location of the hearing and must include a copy of the written complaint, a copy of the Statement of Student Rights and Responsibilities, and copy of the Grievance Procedure.
  3. Four members shall constitute a quorum by which Hearing Committee business may proceed. The quorum must include at least one student member, one faculty member, and one administrative member.
  4. The members of the Hearing Committee shall be provided with a copy of the grievance and any written response provided by the respondent before the hearing begins.
  5. Both parties shall have the right to present personal statements, testimony, evidence, and witnesses. Formal rules of evidence shall not apply. Any relevant evidence shall be admitted. Unless the Hearing Committee determines to proceed otherwise, each party to the grievance shall be permitted to make an opening statement. Thereafter, the grievant or grievants shall make the first presentation, followed by the respondent or respondents. The grievant(s) may present rebuttal evidence after the respondent(s)' evidence. The burden shall be on the grievant or grievants to prove by substantial evidence that the facts alleged are true.
  6. Each party shall have the right to be present, to be accompanied by the person of his or her choice (who may not participate in the hearing), and to question witnesses who are present. In a closed hearing, witnesses shall not be present at the hearing when not testifying, unless all parties and the committee agree to the contrary.
  7. The hearing shall be recorded by the Coordinator of Student Conduct and Grievance, either by audio recording or stenographic recording, and shall be the only recording made. No witness who refuses to be recorded may be permitted to give testimony. The audio or stenographic recording shall remain in the custody of the District, at all times, unless released to a professional transcribing service. Any recognized party to the grievance may request a copy of the recording.
  8. The Hearing Committee Chair shall, at the beginning of the hearing, ask each person present to identify themselves by name, and thereafter shall ask witnesses to identify themselves by name.
  9. The Hearing Committee shall discuss the stated grievance(s), hear testimony, examine witnesses, and receive all available evidence to the charge.
  10. The hearing shall be closed to the public unless otherwise agreed upon in writing by both parties.
  11. The Hearing Committee shall make decisions in private. The Hearing Committee shall write up findings and decisions. Copies of findings and decisions, including majority and minority reports, are to be sent to each party and the appropriate Vice President. The Hearing Committee's decision(s) shall be final unless appealed.
  12. A recording of the proceedings shall be kept in a confidential file in the Office of Student Conduct and Grievance and shall be available at all times to parties directly involved. All documents, communications, and records dealing with the processing of a grievance will be filed separately from the personnel files of the participants. After a period of four years, the grievance file shall be destroyed.
  13. Reprisals of any kind will not be taken by the District or any of its agents against any party of interest or any other participant in the grievance procedure by reason of such participation.
  14. Evidence and testimony given in each case presented shall not be the sole cause of initiating or filing further grievances.
  15. If the grievant does not act within the time limits provided herein, the ability to proceed with the grievance shall be terminated and no further action will be taken.
  16. The number of instructional days indicated at each step herein should be considered a maximum and every effort must be made to expedite the process. Time limits may be extended by mutual consent in writing or by decision of the Hearing Committee.
  17. The Hearing Committee should attempt to reach a decision by discussion and consensus on a workable solution. Voting should be a last course of action.
  18. If in the course of the proceedings a student graduates before a solution is found, the student shall not be denied full consideration under this policy. A student may also submit a grievance after graduation if the grievance did not become known until that time. However, it must be submitted within 30 instructional days after the grievant should have reasonably become aware of the act or condition on which the complaint is based.
- APPEALS PROCESS**
1. If a party wishes to formally appeal a recommendation of the Hearing Committee, an appeal must be submitted within ten instructional days to the appropriate Vice President provided the appropriate Vice President is not a direct party to the grievance. If the appropriate Vice President is a direct party to the grievance, and either party is dissatisfied with the recommendation of the Hearing Committee, an appeal may be submitted to a Vice President/Assistant Superintendent not a direct party to the grievance.

# STUDENT SERVICES AND POLICIES

2. Upon receiving the findings and recommendations of the Hearing Committee, and after examination of the appeal as requested by either party, the appropriate Vice President or alternate may accept or reject the Hearing Committee's decision.
3. If the appropriate Vice President or alternate rejects the Hearing Committee's decision, he or she shall submit his/her decision with the stated reasons for objections to the Hearing Committee within ten instructional days. The Hearing Committee shall within ten instructional days reconsider its decision(s) and submit its decisions to the appropriate Vice President for a final decision.
4. The appropriate Vice President shall transmit his or her final decision to the parties within ten instructional days.
5. An appeal of the appropriate Vice President's decision may be submitted to the President/Superintendent by either party within five instructional days of the appropriate Vice President's decision. The President/Superintendent shall transmit his or her final decision to the parties within ten instructional days.
6. An appeal of the President/Superintendent's decision may be submitted to the Board of Trustees by either party within five instructional days of the President/Superintendent's decision. The Board of Trustees may review an appeal for two consecutive regular Board meetings before making a final determination of the matter at the District level.
7. The President/Superintendent or designee, or the Board of Trustees may reject a Hearing Committee decision only after reviewing a transcription of the involved hearing.

## STUDENT GRADE GRIEVANCE PROCEDURE

A student of the College may present a grade grievance. The California Education Code, Section 76224, quoted, states for a final course grade the conditions upon which grades or grading can be questioned.

"When grades are given for any courses of instruction taught in a community college district, the grade given to each student shall be determined by the instructor of the course and the determination of the student's grade by the instructor, in the absence of mistake, fraud, bad faith, or incompetence, shall be final." "Mistake" may include, but is not limited to, errors made by an instructor in calculating a student's grade and clerical errors.

### Definitions

**Fraud** – Fraud consists of some deceitful practice with intent to deprive another of their right.

**Bad Faith** – Intentional design to mislead or deceive another, or neglect or refusal to fulfill some duty or contractual obligation.

**Incompetence** – That a person is incapable, inefficient, and without the qualities needed to discharge their obligations and duties.

**Mistake** – An unintentional act, omission, or error.

**Instructional Day** - Any day Monday through Friday that all normal college business is conducted, both in the classroom and in the administrative offices. All weekend days and college holidays are excluded.

## STEP I – INDIVIDUAL ACTION

If a student believes they have valid grounds to challenge a final course grade based on the presence of a mistake, fraud, bad faith, or incompetence, they must first meet with the faculty member to attempt to resolve his or her concern informally. Once grades are available, the student is expected to contact their instructor directly to discuss the dispute. If the instructor is not available or is no longer employed, the student should contact the Division Dean.

When challenging a grade, the burden of proof is on the student to provide evidence of mistake, fraud, bad faith, or incompetence.

## STEP II – MANAGEMENT ACTION

Note: If a student files a grade grievance that includes an allegation of unlawful discrimination, including harassment or retaliation, the grievance, or portion of the grievance, will immediately be referred to (i) the Diversity/Compliance/Title IX Officer or to the Vice President of Human Resources or designee per AP 3435, "Intake and Processing of the Complaint" or to (ii) the Cerritos College Section 504/ADA Coordinator per AP 3412, for attempted informal resolution or investigation.

1. The student will submit the Grade Grievance Form on the Office of Student Conduct and Grievance website within 30 instructional days after the completion of the course about which the grade grievance is filed. Information from the form will be used to create a Grade Grievance Petition, provided to the student during the meeting with the Student Conduct Coordinator. Students may obtain an alternate electronic format of this form by request to the Student Conduct Coordinator or Dean of Student Services. Stated deadline still applies.
2. The Student Conduct Coordinator will meet with the student to review this procedure and the Grade Grievance Petition. The student must schedule and meet with the Student Conduct Coordinator within 10 instructional days of submitting the form. If the student wishes to pursue the grievance, the Student Conduct Coordinator will sign and date the Petition and provide to the student. In the absence of the Coordinator, the Dean of Student Services will perform these duties.
3. The student will present a copy of the Grade Grievance Petition and all supporting evidence to the applicable Division Dean within 10 instructional days of obtaining the signature of the Student Conduct Coordinator. The Division Dean may schedule a meeting with the student and the faculty if appropriate. The Division Dean shall render a decision, and communicate the decision in writing to all parties within 15 instructional days. The outcome notice must include a summary of the grievance allegations, findings from review of the grievance and supporting evidence, a statement of analysis and determination, and instructions for appeal.

## STEP III – ADMINISTRATIVE ACTION

If either party is dissatisfied with the decision of the Division Dean, he or she may appeal the matter to the Vice President of Academic Affairs or designee within ten instructional days of the Division Dean's recommendation. The Vice President of Academic Affairs or designee shall call a meeting with the student, the ASCC Chief Justice, the Division Dean, and if needed, the faculty member. The Vice President of Academic Affairs or designee shall transmit his or her decision to the parties within ten instructional days.

The outcome notice must include a summary of the grievance allegations and prior findings, findings from review of the grievance appeal and supporting evidence, a statement of analysis and determination, and instructions for appeal.



# STUDENT SERVICES AND POLICIES

## STEP IV – BOARD OF TRUSTEES ACTION

If either party is dissatisfied with the decision of the Vice President of Academic Affairs or designee, an appeal may be submitted to the Board of Trustees. The appeal must be submitted within ten instructional days of the Vice President of Academic Affairs or designee's decision. The Board may review an appeal for two consecutive regular Board meetings during closed session, and if needed, request persons involved in the grievance to appear before making a final determination of the matter at the District level. Following final determination, the outcome will be recorded in the Board minutes and notice provided to all parties in writing from the Office of the President within ten instructional days. The outcome notice must include a summary of the grievance allegations and prior findings, findings from review of the grievance appeal and supporting evidence, and the statement of final determination.

Any times specified in these procedures may be shortened or lengthened if there is mutual concurrence by all parties.

## ADDITIONAL INFORMATION

Most complaints, grievances, and disciplinary matters should be resolved at the college level. If a complaint does not fall into one of the college's established procedures, it may be addressed in writing to the President/Superintendent. Individuals are strongly encouraged to make every attempt to resolve matters through the appropriate administrative processes.

Matters that are not resolved at the college level may be submitted to one or more of the following agencies for consideration:

- The Accrediting Commission for Community and Junior Colleges (ACCJC) at <http://www.accjc.org/complaint-process>, if the complaint is associated with the institution's compliance with academic program quality and accrediting standards. The ACCJC is the agency that accredits the academic programs of the California Community Colleges.
- If the complaint does not concern the college's compliance with academic program quality and accrediting standards, it may be directed to the California Community Colleges Chancellor's Office by completing the web form found at <http://californiacommunitycolleges.cccco.edu>.

## STANDARDS OF STUDENT CONDUCT

The President/Superintendent shall establish procedures for the imposition of discipline on students in accordance with the requirements for due process of the state and federal laws and regulations.

The procedures shall clearly define the conduct that is subject to discipline, and shall identify potential disciplinary actions, including but not limited to the removal, suspension, or expulsion of a student.

A complainant or witness who participates in an investigation of sexual assault, domestic violence, dating violence, or stalking will not be subject to disciplinary sanctions for a violation of the District's student conduct policy at or near the time of the incident, unless the District determines that the violation was egregious, including but not limited to, an action that places the health or safety of any other person at risk or involves plagiarism, cheating, or academic honesty.

Due process requires that in all significant disciplinary situations a student is informed of charges against him/her, is given an opportunity to refute them, and has the opportunity to appeal a decision.

The Board of Trustees shall consider any recommendation from the President/Superintendent for expulsion. The Board of Trustees shall consider an expulsion recommendation in closed session unless the student requests that the matter be considered in a public meeting. Final action by the Board of Trustees on the expulsion shall be taken at a public meeting.

The procedures shall be made widely available to students through the College catalog and other means.

Students enrolling in Cerritos College assume an obligation to abide by all District regulations on District-owned or controlled property or at District-sponsored or supervised functions.

Students who fail to adhere to District regulations are subject to disciplinary actions.

In all disciplinary actions, the student shall be informed of the nature of the charges against him/her and given a fair opportunity to refute them. The District shall not be arbitrary in its actions.

The following conduct while on District-owned or controlled property or at District-sponsored or supervised functions shall constitute good cause for discipline, including but not limited to the removal, suspension, or expulsion of a student.

1. Assault, battery, or any threat of force or violence, or causing, attempting to cause, or threatening to cause physical injury to another person, in person or in an online environment and, when the victim or victims are associated with the District, whether or not the location is associated with the District.
2. Possession, use, sale, or otherwise furnishing any firearm, knife, explosive, or other dangerous object or chemical, including but not limited to any facsimile firearm, knife, or explosive on District-owned or controlled property or at District-sponsored or supervised functions without the prior authorization of the President/Superintendent or designee.
3. Unlawful possession, use, sale, offer to sell, or furnishing, or being under the influence of, any controlled substance listed in Chapter 2 (commencing with Section 11053) of Division 10 of the California Health and Safety Code, an alcoholic beverage, or an intoxicant of any kind; or unlawful possession of, or offering, arranging, or negotiating the sale of any drug paraphernalia, as defined in California Health and Safety Code, Section 11014.5.
4. Committing or attempting to commit robbery or extortion.
5. Theft, attempted theft of, or willful damage to District property or property in the possession of, or owned by, a member of the college community or knowingly receiving stolen property or private property on District premises.
6. Willful or persistent smoking in any area where smoking has been prohibited by law or by regulation of the District.
7. Committing sexual harassment as defined by law or by District policies and procedures in person or in an online environment and, when the victim or victims are associated with the District, whether or not the location is associated with the District.
8. Engaging in harassing or discriminatory behavior based on national origin, religion, age, gender, gender identity, gender expression, race or ethnicity, color, medical condition, genetic information, ancestry, sexual orientation, marital status, physical or mental disability, pregnancy, or because he or she is perceived to have one or more of the foregoing characteristics, or based on association with a person or group with one or more of these actual or perceived characteristics, or any other status protected by law in person or in an online environment and, when the victim or victims are associated with the District, whether or not the location is associated with the District.
9. Engaging in intimidating conduct or bullying against another student through words or actions, including direct physical contact; verbal assaults, such as teasing or name-calling; social isolation or manipulation; and cyberbullying.

## STUDENT SERVICES AND POLICIES

---

10. Willful misconduct that results in injury or death to a student, client, patient, visitor, guest, or to District personnel or that results in cutting, defacing, or other injury to any real or personal property owned by the District or on campus.
11. Endangering a student, client, patient, visitor, guest, or District employee or contributing to or causing harm to the health, safety, and/or well-being of such others.
12. Disruptive behavior, continual or willful disobedience and/or persistent defiance of the authority, habitual profanity or vulgarity, or abuse of District personnel or where the presence of the student causes a continuing danger to the physical safety of students or others.
13. Cheating, or engaging in other academic dishonesty including copying from another's work; discussion prohibited by the instructor; obtaining exam copies without permission; and using notes, other information, or devices that have been prohibited.
14. Misrepresentation and/or impersonation, including arranging for or allowing another individual to impersonate or otherwise misrepresent himself or herself to be a student generally or to be a particular student either in person or in an online environment, and/or impersonating or otherwise misrepresenting oneself to be another person in person or in an online environment.
15. Plagiarism, in individual or group work or in a student publication, including the act of taking the ideas, words or specific substantive material of another and offering them as one's own without giving credit to the source.
16. Dishonesty; forgery; alteration or misuse of District documents, records, or identification; or knowingly furnishing false information to the District.
17. Unauthorized entry upon, into, or use of District facilities, either in person or in an online environment.
18. Lewd, indecent or obscene conduct on District-owned or controlled property; or at District-sponsored or supervised functions; or directed at and for the purpose of harming another individual or group associated with the District, whether carried out in person or in an online environment, and whether or not the location is associated with the District.
19. Engaging in expression that is obscene, libelous or slanderous, or that so incites students as to create a clear and present danger of the commission of unlawful acts on college premises, or the violation of lawful District administrative procedures, or the substantial disruption of the orderly operation of the District.
20. Persistent serious misconduct where other means of correction have failed to bring about proper conduct.
21. Unauthorized preparation, giving, selling, transfer, distribution, or publication, for any commercial purpose, of any contemporaneous recording of an academic presentation in a classroom or equivalent site of instruction, including but not limited to handwritten or typewritten class notes, except as permitted by any Board policy or administrative procedure.
22. Unauthorized use of audio, video or other listening, recording or transmitting device in any classroom, service area, or District activity without prior consent of the instructor, service area manager, or activity advisor except as necessary for reasonable accommodation.
23. Failure, as a person involved in sexual activity, to ensure that he or she has the affirmative consent of the other or others to engage in the sexual activity. Lack of protest or resistance does not mean consent, nor does silence mean consent.
  - Affirmative consent must be ongoing throughout a sexual activity and can be revoked at any time. The existence of a dating relationship between the persons involved, or the fact of past sexual relations between them, should never by itself be assumed to be an indicator of consent. "Affirmative consent" means affirmative, conscious, and voluntary agreement to engage in sexual activity.
    - a. In the evaluation of complaints in any disciplinary process, it shall not be a valid excuse to alleged lack of affirmative consent that the accused believed that the complainant consented to the sexual activity under either of the following circumstances:
      - i. The accused's belief in affirmative consent arose from the intoxication or recklessness of the accused.
      - ii. The accused did not take reasonable steps, in the circumstances known to the accused at the time, to ascertain whether the complainant affirmatively consented.
    - b. In the evaluation of complaints in the disciplinary process, it shall not be a valid excuse that the accused believed that the complainant affirmatively consented to the sexual activity if the accused knew or reasonably should have known that the complainant was unable to consent to the sexual activity under any of the following circumstances:
      - i. The complainant was asleep or unconscious.
      - ii. The complainant was incapacitated due to the influence of drugs, alcohol, or medication, so that the complainant could not understand the fact, nature, or extent of the sexual activity.
      - iii. The complainant was unable to communicate due to a mental or physical condition.
24. Sexual assault, defined as actual or attempted sexual contact with another person without that person's consent, regardless of the victim's affiliation with the college; and, effective January 1, 2016, regardless of whether such conduct is related to college activity or college attendance; including, but not limited to, any of the following: (1) Intentional touching of another person's intimate parts without that person's consent or other intentional sexual contact with another person without that person's consent. (2) Coercing, forcing, or attempting to coerce or force a person to touch another person's intimate parts without that person's consent. (3) Rape, which includes penetration, no matter how slight, without the person's consent, of either of the following: (A) The vagina or anus of a person by any body part of another person or by an object. (B) The mouth of a person by a sex organ of another person.
25. Sexual exploitation, defined as a person taking sexual advantage of another person for the benefit of anyone other than that person without that person's consent, regardless of the victim's affiliation with the college; and, effective January 1, 2016, regardless of whether such conduct is related to college activity or college attendance; including, but not limited

# STUDENT SERVICES AND POLICIES

to, any of the following: (1) Prostituting another person. (2) Recording images, including video or photograph, or audio of another person's sexual activity, intimate body parts, or nakedness without that person's consent. (3) Distributing images, including video or photograph, or audio of another person's sexual activity, intimate body parts, or nakedness, if the individual distributing the images or audio knows or should have known that the person depicted in the images or audio did not consent to the disclosure and objected to the disclosure. (4) Viewing another person's sexual activity, intimate body parts, or nakedness in a place where that person would have a reasonable expectation of privacy, without that person's consent, and for the purpose of arousing or gratifying sexual desire.

26. Misrepresentation of oneself or of an organization to be an agent of the District.
27. Continued disruption on or off District property of the District's educational or student services activities, administrative functions and procedures, public service functions, authorized curricular or co-curricular activities, other functions, or prevention of authorized guests from carrying out the purpose for which they are on District property.
28. Abuse of any person, or any possession of any person, on District-owned or controlled property.
29. Violation of state or local laws, Board policies, or administrative procedures concerning the registration of student organizations, the use of District facilities, or the time, place, and manner of public expression.
30. Abusive behavior directed toward coercion of, or hazing of, or bullying of a member of the college community, in person or in an online environment and, when the victim or victims are associated with the District, whether or not the location is associated with the District.
31. Violation of Board policies or administrative procedures governing the use of student user accounts, Computers, and telecommunication resources, including but not limited to the unauthorized entry, opening, or viewing of a file; the unauthorized use of another individual's identification and password; arranging for, allowing, and/or impersonation of one person by another; sending obscene or abusive messages or files; and/or use of computing facilities to interfere with the work of another student or employee of the District.
32. Engaging in physical or verbal disruption, intimidation, or harassment of such severity or pervasiveness as to have the purpose or effect of unreasonably interfering with a student's academic performance, or District employee's work performance, or of creating an intimidating, hostile or offensive educational or work environment, in person or in an online environment and, when the victim or victims are associated with the District, whether or not the location is associated with the District.
33. Violation of a duly issued restraining order, stalking, and/or a pattern of conduct with intent to follow, alarm, or harass another person, and which causes the person to reasonably fear for his or her safety, and where the pattern of conduct persisted after the person has demanded that the pattern of conduct cease.
34. Failure to identify oneself when requested to do so by District officials acting in the performance of their duties.
35. Any other cause not listed above which is identified as "Good Cause" by the Education Code or that disrupts the college, its mission, or campus life.

## ACADEMIC HONESTY/DISHONESTY POLICY

Your instructors are eager to help you succeed in your studies at Cerritos College. But success means more than just receiving a passing grade in a course. Success means that you have mastered the course content so that you may use that knowledge in the future, either to be successful on a job, or to continue on with your education in advanced classes.

Your success depends on a combination of the skill and knowledge of your instructors, and your own hard work. You will reach your future goals only if you gain new knowledge from every course you take. That knowledge becomes yours and can be used by you, only if it is gained through your own personal efforts. Receiving a grade in a course, without acquiring the knowledge that goes with it, diminishes your chances for future success.

While in college, you are also shaping the principles which will guide you throughout the rest of your life. Ethical behavior and integrity are a vital part of those principles. A reputation for honesty says more about you, and is more highly prized, than simply your academic skills.

For this reason, academic honesty is taken very seriously by the Cerritos College faculty. The following guidelines have been prepared so that you will understand what is expected of you in maintaining academic honesty.

Academic Dishonesty is normally to be dealt with as an academic action by the instructor, reflected in the student's grade in the particular course, rather than through college disciplinary procedures. No specific departmental, divisional or institutional procedures are established for academic dishonesty other than the normal process for review and appeal of an instructor's grading procedures.

Academic Dishonesty is defined as the act of obtaining or attempting to obtain credit for work by the use of any dishonest, deceptive, or fraudulent means. Examples of academic dishonesty would include, but not be limited to the following:

- Copying, either in part or in whole, from another's test or examination;
- Discussion of answers or ideas relating to the answers, on examination or test when such discussion is prohibited by the instructor;
- Obtaining copies of an exam without the permission of the instructor;
- Using notes, "Cheat sheets," or otherwise utilizing information or devices not considered appropriate under the prescribed test conditions;
- Altering a grade or interfering with the grading procedures in any course;
- Allowing someone other than the officially enrolled student to represent the same;
- Plagiarism, which is defined as the act of taking the ideas, words or specific substantive material of another and offering them as one's own without giving credit to the source.

Options may be exercised by the faculty member to the extent that the faculty member considers the cheating or plagiarism to manifest the student's lack of scholarship or to reflect on the student's lack of academic performance in the course. One or more of the following actions are available to the faculty member who suspects a student has been cheating or plagiarizing:

1. Review-no action.
2. An oral reprimand with emphasis on counseling toward prevention of further occurrences.
3. A requirement that work be repeated.
4. A reduction of the grade earned on the specific work in question, including the possibility of no credit for the work.

# STUDENT SERVICES AND POLICIES

5. A reduction of the course grade as a result of item 4 above, including the possibility of a failing grade for the course.
6. Referral to the Office of Student Conduct and Grievance for further administrative action, such as suspension or expulsion.

## STUDENT DISCIPLINE PROCEDURES

Student Conduct Programs should contribute to the teaching of appropriate individual and group behavior as well as to protecting the campus community from disruption and harm. The Programs should be conducted in ways that will serve to foster the ethical development and personal integrity of students and the promotion of an environment that is in accord with the overall educational goals of the institution. This procedure will be used in a fair and equitable manner, and not for purposes of retaliation. It is not intended to substitute for criminal or civil proceedings that may be initiated by other agencies.

These Administrative Procedures are specifically not intended to infringe in any way on the rights of students to engage in free expression as protected by the state and federal constitutions, and by Education Code Section 76120, and will not be used to punish expression that is protected.

The Office of Student Conduct and Grievances is responsible for the student conduct and sanctioning procedures of the college. Inquiries should be directed to the Office of Student Conduct and Grievances.

## STUDENT CONDUCT PROCEDURES AND SANCTIONS

### Definitions

**District** – The Cerritos Community College District.

**Day** – A day is defined as any day Monday through Friday that all normal College business is conducted, both in the classroom and in the administrative offices. All weekend days and College holidays are excluded.

**Student** – Any person currently enrolled as a student of the District.

**Instructor** – Any academic employee of the District in whose class a student subject to discipline is or was enrolled, or counselor who is providing or has provided services to the student, or other academic employee who has responsibility for the student's educational program.

**Written or verbal reprimand** – An admonition to the student to cease and desist from conduct determined to violate the Standards of Student Conduct. Written reprimands may become part of a student's permanent record at the college. A record of the fact that a verbal reprimand has been given may become part of a student's record at the college for a period of up to one year.

**Disciplinary Probation** – A period on probation that may include, but is not limited to, exclusion of the individual from designated co-curricular activities of the college for a set period of time.

**Removal from class** – Exclusion of the student by an instructor for the day of the removal and the next class meeting.

**Withdrawal of Consent to Remain on Campus** – Withdrawal of consent by the President/Superintendent or designee for any person to remain on campus in accordance with California Penal Code Section 626.4 where the President/Superintendent or designee has reasonable cause to believe that such person has willfully disrupted the orderly operation of the campus.

**Short-term Suspension** – Exclusion of the student by the President/Superintendent or designee for good cause from one or more classes for a period of up to ten consecutive days of instruction.

**Long-term Suspension** – Exclusion of the student by the President/Superintendent or designee for good cause from one or more classes for the

remainder of the school term, or from all classes and activities of the college for one or more terms.

**Expulsion** – Exclusion of the student by the Board of Trustees from the District for one or more terms.

### **Short-term Suspensions, Long-term Suspensions, and Expulsions**

Before any disciplinary action to suspend, or expel is taken against a student, the following procedures will apply:

**Notice** – The President/Superintendent or designee will provide the student with written notice of the conduct warranting the discipline. The written notice will include the following:

- the specific section of the Standards of Student Conduct that the student is accused of violating.
- a short statement of the facts supporting the accusation.
- the right of the student to meet with the Dean of Student Services or designee to discuss the accusation, or to respond in writing.
- the nature of the discipline that is being considered.

**Time limits** – The notice must be provided to the student within 20 days of the date on which the administration of the college became aware of the conduct; in the case of continuous, repeated, or ongoing conduct of which the administration of the college has become aware, the notice must be provided within 20 days of the date on which the administration became aware that the conduct occurred which led to the decision to take disciplinary action.

**Hearing Officer Meeting** – The student is to have a hearing with the Dean of Student Services or designee serving as the district hearing officer. The hearing must occur no sooner than five days after the notice is provided. At the meeting, the student must again be told the facts leading to the accusation, and must be given an opportunity to respond verbally or in writing to the accusation.

**Short-term Suspension** – Within five days after the meeting described above, the President/Superintendent or designee shall, pursuant to a recommendation from the Dean of Student Services or designee, decide whether to impose a short-term suspension, whether to impose some lesser disciplinary action, or whether to end the matter. Written notice of the President/Superintendent's or designee's decision shall be provided to the student. The notice will include the length of time of the suspension, or the nature of the lesser disciplinary action. The President/Superintendent or designee decision on a short-term suspension shall be final.

**Long-term Suspension** – Within five days after the meeting described above, the President/Superintendent or designee shall, pursuant to a recommendation from the Dean of Student Services or designee, decide whether to impose a long-term suspension. Written notice of the President/Superintendent or designee decision shall be provided to the student. The notice will include the right of the student to request a formal hearing before the hearing panel before a long-term suspension is imposed, and a copy of this policy describing the procedures for a hearing. The request must be made in writing to the Vice President of Student Services or designee.

**Expulsion** – Within 10 days after the meeting described above, the President/Superintendent or designee shall, pursuant to a recommendation from the Dean of Student Services or designee, decide whether to recommend expulsion to the Board of Trustees. Written notice of the decision shall be provided to the student. The notice will include the right

**Smoking, including the use of electronic cigarettes or other emission-producing products or devices, is prohibited within 20 feet of any exit, entrance, operable window, or ventilation intake of any campus building or structure; in any enclosed area on campus, including lobbies, lounges, courtyards, waiting areas, stairwells, and restrooms that are a part of any building or structure; and in all District vehicles, including gasoline or electric carts.**

## STUDENT SERVICES AND POLICIES

of the student to request a formal hearing before the hearing panel before expulsion is imposed, and a copy of this policy describing the procedures for a hearing. The request must be made in writing to the Vice President of Student Services or designee.

A decision of the Board of Trustees to impose expulsion shall be reached no later than the next regularly scheduled regular meeting of the Board after receipt of the recommended decision.

### ***Disciplinary Decisions, Sanctions, and Conditions***

**Written or Verbal Reprimand** – May be initiated by any faculty or College manager and sent in writing to the Office of Student Conduct and Grievances. The Disciplinary Officer (Dean of Student Services or designee) shall determine if there exists good and sufficient reason to initiate disciplinary action and the student should be notified of such actions.

**Disciplinary Probation** – Initiated by the Dean of Student Services or designee. The nature of the misconduct, dates, times, places, and the length of probation shall be placed in writing. Written copies shall be sent to the student and copies filed with the Office of Student Conduct and Grievances.

**Removal from Class (Education Code Section 76032)** – Any instructor may order a student removed from his/her class for the day of the removal and the next class meeting. The instructor shall immediately report the removal to the Faculty Coordinator for Student Conduct and Grievance and complete a Student Conduct Incident Form. The Faculty Coordinator or designee shall arrange for a conference between the student and the instructor regarding the removal. If the instructor or the student requests, the Faculty Coordinator or designee shall attend the conference. The student shall not be returned to the class during the period of the removal without the concurrence of the instructor. Nothing herein will prevent the Faculty Coordinator, or designee from recommending further disciplinary procedures in accordance with these procedures based on the facts which led to the removal.

**Immediate Interim Suspension (Education Code Section 66017)** – The President/Superintendent or designee may order immediate suspension of a student where he or she concludes that immediate suspension is required to protect lives or property and to ensure the maintenance of order. In cases where an interim suspension has been ordered, the time limits contained in these procedures shall not apply, and all hearing rights, including the right to a formal hearing where a long-term suspension or expulsion is recommended, will be afforded to the student within ten days.

**Withdrawal of Consent to Remain on Campus** – The President/Superintendent or designee may notify any person for whom there is a reasonable belief that the person has willfully disrupted the orderly operation of the campus that consent to remain on campus has been withdrawn. If the person is on campus at the time, he/she must promptly leave or be escorted off campus. If consent is withdrawn by the Dean of Student Services or designee, a written report must be promptly made to the President/Superintendent or designee.

The person from whom consent has been withdrawn may submit a written request for a hearing on the withdrawal within the period of the withdrawal. The request shall be granted not later than seven days from the date of receipt of the request. The hearing will be conducted in accordance with the provisions of this procedure relating to interim suspensions.

In no case shall consent be withdrawn for longer than 14 days from the date upon which consent was initially withdrawn.

All applicable conditions of a withdrawal of consent to remain on campus, suspension, or expulsion in effect when a break occurs in the conducting of College business (both in the classroom and in the administrative offices) remain in effect during the break unless specifically excepted in writing by the President/Superintendent or designee.

A withdrawal of consent to remain on campus, suspension, or expulsion prohibits both physical presence on the campus and at a facility or activity operated by the College and any type of online or distance education presence or participation in classes, activities, and/or operations of the College.

Any person as to whom consent to remain on campus has been withdrawn who knowingly reenters the campus during the period in which consent has been withdrawn, except to come for a meeting or hearing, is subject to arrest (Penal Code Section 626.4).

**Clearance to Return** – Prior clearance to return to the college (in-person and/or online) may be required. Clearance requirements may include completion of educational or other courses or processes as specified in the sanction decision. This requirement may include confirmation that the individual is ready for the college classroom and/or that the individual's continued presence on campus is not a threat to himself/herself, others, and/or the property of the District or others.

### ***Hearing Panel***

The hearing panel for any disciplinary action subject to hearing by a panel shall be composed of one administrator, two faculty members, and two students.

Unless he or she determines to keep the prior year's appointees in place, the president of the Faculty Senate, and the President of ASCC shall each, at the beginning of the academic year, establish a list of at least five persons who will serve on student disciplinary hearing panels. The President/Superintendent or designee shall appoint the hearing panel from the names on these lists plus the Dean of Student Services or designee. However, no administrator, faculty member, or student who has any personal involvement in the matter to be decided, who is a necessary witness, or who could not otherwise act in a neutral manner shall serve on a hearing panel.

The hearing panel shall be responsible to the President/Superintendent for reviewing and making a recommendation to the President/Superintendent or designee.

Membership of the hearing panel shall include the following:

1. Two members of the instructional staff appointed by the Faculty Senate.
2. Two ASCC Student Court Justices, or two other students who meet the minimum eligibility requirements to hold office in the ASCC if such justices are party to the matter at hand or are otherwise unavailable to serve, appointed by the ASCC Court Chief Justice or by the Associated Students President, if the Court Chief Justice is a party to the matter.
3. The Disciplinary Officer/Dean of Student Services or designee shall serve as the Chairperson of the Hearing Panel, but will not vote except to break a tie.

# STUDENT SERVICES AND POLICIES

## ***Procedures for a Hearing, Disposition, and Imposition of Sanctions***

1. Written notice of a hearing shall be mailed or delivered to the student. A hearing must be held within ten days of the suspension if the suspension is immediate.
2. Notice shall include date and place of hearing, a statement of all charges, a copy of applicable policies and procedures, the opportunity of the student to appear in person, and the opportunity to present oral and documentary evidence.
3. Hearings shall be conducted in the manner consistent with the orderly conduct of the affairs of the College, and which seems to the hearing panel to be most conducive to the determination of the truth.
4. The members of the hearing panel shall be provided with a copy of the accusation against the student and any written response provided by the student before the hearing begins.
5. The facts supporting the accusation shall be presented by a college representative who shall be the Dean of Student Services or designee.
6. The college representative and the student may call witnesses and introduce oral and written testimony relevant to the issues of the matter.
7. Formal rules of evidence shall not apply. Any relevant evidence shall be admitted.
8. Unless the hearing panel determines to proceed otherwise, the college representative and the student shall each be permitted to make an opening statement. Thereafter, the college representative shall make the first presentation, followed by the student. The college representative may present rebuttal evidence after the student completes his/her evidence. The burden shall be on the college representative to prove by the preponderance of the evidence that the facts alleged are true.
9. The student may represent himself/herself, and may also have the right to be represented by a person of his/her choice, except that the student shall not be represented by an attorney unless, in the judgment of the hearing panel, complex legal issues are involved. If the student wishes to be represented by an attorney, a request must be presented not less than five days prior to the date of the hearing. If the student is permitted to be represented by an attorney, the college representative may request that legal counsel to the college participate in his/her place. The hearing panel may also request legal assistance; any legal advisor provided to the panel may sit with it in an advisory capacity to provide legal counsel but shall not be a member of the panel nor vote with it.
10. Hearings shall be closed and confidential unless the student requests that it be open to the public. If more than one student's case is under consideration, any and all such other students must also request that the hearing be open to the public in order to make it open to the public. Any such request must be made no less than five days prior to the date of the hearing. Requests contrary to state or federal law or to the safety of the college or participants shall not be approved, subject to appeal to the President/Superintendent or designee.
11. In a closed hearing, witnesses shall not be present at the hearing when not testifying, unless all parties and the panel agree to the contrary.
12. All testimony shall be taken under oath; the oath shall be administered by the hearing panel chair. Written statements of witnesses under penalty of perjury shall not be used unless the witness is unavailable to testify. A witness who refuses to be tape recorded shall not be considered unavailable for the purposes of this section.
13. The hearing shall be recorded by the District either by tape recording or stenographic recording. The official recording shall be the only recording made. No witness who refuses to be recorded may be permitted to give testimony. In the event the recording is by tape recording, the hearing panel chair shall, at the beginning of the hearing, ask each person present to identify themselves by name, and thereafter shall ask witnesses to identify themselves by name. The recording shall remain in the custody of the District at all times, unless released to a professional transcribing service. The student may request a copy of the recording. Transcripts may be redacted to comply with law, policies, and to protect the privacy and/or safety of individuals.
14. Within five days following the close of the hearing, the hearing panel shall prepare and send to the President/Superintendent or designee a written decision. The decision shall include specific factual findings regarding the accusation, and shall include specific conclusions regarding whether any specific section of the Standards of Student Conduct were violated. The decision shall also include a specific recommendation regarding the sanction to be imposed, if any. The decision shall be based only on the record of the hearing, and not on matter outside of that record. The record consists of the original accusation, the written response, if any, of the student, and the oral and written evidence produced at the hearing.

### ***President/Superintendent's Decision:***

**Long-term suspension** – Within five days following receipt of the hearing panel's recommended decision, the President/Superintendent or designee shall render a final written decision. The President/Superintendent or designee may accept, modify, or reject the findings, decisions and recommendations of the hearing panel. If the President/Superintendent or designee modifies, or rejects the hearing panel's decision, the President/Superintendent or designee shall review the record of the hearing, and shall prepare a new written decision which contains specific factual findings and conclusions. The decision of the President/Superintendent or designee shall be final.

**Expulsion** – Within ten days following receipt of the hearing panel's recommended decision, the President/Superintendent or designee shall render a written recommended decision to the Board of Trustees. The President/Superintendent or designee may accept, modify, or reject the findings, decisions and recommendations of the hearing panel. If the President/Superintendent or designee modifies, or rejects the hearing panel's decision, he/she shall review the record of the hearing, and shall prepare a new written decision which contains specific factual findings and conclusions. The President/Superintendent's or designee's decision for expulsion shall be forwarded to the Board of Trustees.

### ***Board of Trustees Decision:***

**Expulsion** – A decision of the Board of Trustees to impose expulsion shall be reached no later than the next regularly scheduled regular meeting of the Board after receipt of the recommended decision.

# STUDENT SERVICES AND POLICIES

The Board shall consider an expulsion recommendation in closed session, unless the student has requested that the matter be considered in a public meeting in accordance with these procedures. (Education Code Section 72122)

The student shall be notified in writing, by registered or certified mail to the address last on file with the District, or by personal service, at least three days prior to the meeting, of the date, time, and place of the Board's meeting.

The student may, within forty-eight hours after receipt of the notice, request that the hearing be held as a public meeting.

Even if a student has requested that the Board consider an expulsion recommendation in a public meeting, the Board will hold any discussion that might be in conflict with the right to privacy of any student other than the student requesting the public meeting in closed session.

The Board may accept, modify, or reject the findings, decisions and recommendations of the President/Superintendent and/or the hearing panel. If the Board modifies or rejects the decision, the Board shall review the record of the hearing, and shall prepare a new written decision which contains specific factual findings and conclusions. The decision of the Board shall be final.

The final action of the Board on the expulsion shall be taken at a public meeting, and the result of the action shall be a public record of the District. **Time Limits** – Any times specified in these procedures may be shortened or lengthened if there is mutual concurrence by all parties.

These procedures may change from time to time and may be superseded by current state and federal laws and regulations. Otherwise, the College Catalog, which is updated annually, contains the most recent information regarding student discipline procedures.

Also see BP 5500 titled Standards of Student Conduct.

## STUDENT CONDUCT AND GRIEVANCE

Information regarding student rights and responsibilities is available from the Dean of Student Services. The dean is available to meet with you to explain the "System" and your rights with regard to student grievances, student conduct and academic-related student grievances. This office also serves as a source of information and/or referral for all student problems and concerns. The office is located in the Office of Student Affairs. Inquiries should be directed to the Dean of Student Services in the Office of Student Affairs or by calling (562) 860-2451, ext. 2445.

## TITLE IX POLICY

No person in the United States shall, on the basis of sex, be excluded from participation in, be denied the benefits of, or be subject to discrimination under any educational program or activity receiving Federal financial assistance (Title IX of the Educational Amendments of 1972 to the 1964 Civil Rights Act).

It is the policy of the State of California to afford all persons, regardless of their sex or gender identity, equal rights and opportunities in the educational institutions of the state (Educational Code sections 200 – 264).

In compliance with Title IX and Board Policy 3410, the District's educational programs and activities are offered to the community without regard to sex or gender identity. Title IX prohibits discrimination based on sex in educational programs and activities that receive Federal financial assistance. Examples of programs and activities that are subject to Title IX include admissions, recruitment, financial aid, academic programs, athletics and employment. Title IX also protects students from sexual harassment, including sexual violence, such as rape, other forms of sexual assault, sexual battery and sexual coercion. New Title IX Regulations in Spring 2020: The District's effort to implement the new requirements is ongoing. Please visit the Title IX website at <https://www.cerritos.edu/title-ix> for updated information.

### Title IX Coordinator

Cerritos College's Title IX Coordinator monitors and oversees the college's compliance with Title IX and the prevention of sex harassment and discrimination, including the coordination of education and training activities and the response to Title IX complaints. Students, faculty, administrators, staff, visitors, or others who participate in the District's educational programs and activities with questions, concerns, or complaints about sex discrimination, sex harassment or sexual misconduct are encouraged to contact the Title IX Coordinator at:

Dr. Valyncia C. Raphael

Director of Diversity, Compliance, and Title IX Coordinator

Office of Human Resources

Cerritos College, 11110 Alondra Blvd., Norwalk, CA 90650

(562) 860-2451, ext. 2276; (562) 467-5003 Fax

<https://www.cerritos.edu/title-ix/>



# STUDENT SERVICES AND POLICIES

## EQUAL OPPORTUNITY POLICY

Cerritos College does not discriminate in educational and employment on the basis of ancestry, age, color, creed, disability (physical and mental, includes HIV and AIDS), genetic information, gender identity, gender expression, marital status, medical condition (genetic characteristics, cancer or a record or history of cancer), military or veteran status, national origin, race, religion (includes religious dress and grooming), sex/gender (includes pregnancy, childbirth, breastfeeding and/or related medical conditions), sexual orientation, or on the basis of perception of having one or more of the foregoing characteristics, or based on association with a person or group with one or more of these actual or perceived characteristics, or any other status protected by law in person or in an online environment and, when the victim or victims are associated with the District, whether or not the location is associated with the District.

The District is strongly committed to achieving staff diversity and the principles of equal opportunity education and employment. The District encourages a diverse pool of applicants for employment and does not discriminate in any of its policies, procedures, or practices. The District encourages applications from all segments of qualified people and Board Policies 3410 and 3420 prohibit discrimination and promote equal opportunity.

Questions concerning the application of the policy may be addressed to Dr. Valyncia C. Raphael in the Office of Human Resources by calling (562) 860-2451, ext. 2276.

## SECTION 504/508/AMERICANS WITH DISABILITIES ACT

Under Section 504/508/ADA of the Rehabilitation Act of 1973 and Title II of the Americans with Disabilities Act of 1990, Cerritos College will take all necessary steps to ensure that no student with a verified disability is denied the benefits of, excluded from participation in, or otherwise subjected to discrimination because of the absence of auxiliary aids or academic accommodations. The decision to authorize such aids or accommodations is the responsibility of the Dean of Student Accessibility and Wellness Services

(SAWS), Student Accessibility Services (SAS), Disability Specialist, or SAS counselor after a review of documentation verifying the disability and any resulting educational limitations.

It is the responsibility of the student with a verified disability and resulting educational limitations to apply for SAS assistance by completing the SAS form entitled “Student Accessibility Services – New Student Application” available on the SAS website at [www.cerritos.edu/sas](http://www.cerritos.edu/sas). The request should be completed with adequate notice provided for an effective response, especially during busy times such as the start of the semester. All authorized accommodations are determined via an interactive process which includes the SAS specialist, the student, and review of disability documentation. It is the student’s responsibility to request in advance to receive the authorized accommodations each semester. If the instructor denies the classroom-related request(s) the SAWS Dean or designee will intervene with the appropriate academic staff and attempt to resolve the matter. In the event of continued denial of an accommodation request or request for course substitution or waiver, SAS will provide the student with the Academic Accommodations Policy and related procedures/forms. The SAWS Dean or designee will concurrently inform the student that he/she has the right to file a complaint under the College’s discrimination complaint procedure and/or the Office for Civil Rights, and will provide the student with the information necessary to do so. Inquiries regarding SAS or the District’s non-discrimination policy relative to students, employees, or applicants with disabilities should contact the Director of Diversity, Compliance, and Title IX Coordinator at extension 2276, in the Office of Human Resources.

## SECTION 504/508 COMPLAINT PROCEDURE

The student should first discuss the complaint regarding discrimination due to a disability with the individual(s) involved or with the Director of Diversity, Compliance, and Title IX Coordinator at extension 2276. Alternatively the student may submit a complaint electronically at <https://www.cerritos.edu/sas-complaint>.





# ALCOHOL AND DRUG POLICY

## BP 3550 – DRUG AND ALCOHOL FREE ENVIRONMENT AND DRUG AND ALCOHOL ABUSE PREVENTION PROGRAM

The District shall maintain a drug and alcohol free campus/workplace environment for students and employees. The District prohibits the unlawful possession, use, or distribution of illicit drugs and/or alcohol by students and employees.

The unlawful manufacture, distribution, dispensing, possession, or use of a controlled substance is prohibited in all facilities under the control and use of the District.

Any student who violates this policy will be subject to disciplinary action, which may include, but is not limited to, referral to an appropriate rehabilitation program, suspension or expulsion. Any employee who violates this policy will be subject to disciplinary action up to and including termination. The District may refer students and employees who violate this policy to the Campus Police or other appropriate law enforcement agency for appropriate criminal action.

The President/Superintendent shall assure that the District annually distributes the information required by the Drug-Free Schools and Communities Act Amendments of 1989 to all students and employees and that the District complies with other requirements of the Act.

The President/Superintendent shall ensure that a biennial report is prepared to review the effectiveness of the District's policies and programs in maintaining a drug and alcohol free campus and workplace environment.

The District is committed to providing its employees and students with an alcohol and drug-free campus and workplace environment. It emphasizes prevention and intervention through education.

### Health Risks That May Be Associated with the Use of Illicit Drugs and the Abuse of Alcohol

- Partner and/or child abuse.
- Unintended injuries or death, including motor vehicle crashes.
- Sexual assault, including rape, sexual battery, and threat of sexual assault; dating violence; domestic violence; stalking; and failure to have affirmative consent.
- Being hit, otherwise assaulted, violently attacked, and/or murdered by another under the influence.
- Sexual activity without protection against HIV, hepatitis (A, B, and C), and other STDs.
- Unsafe interactions with medications, including more than 150 medications that should not be mixed with alcohol.
- Binge and other drinking behaviors leading to ingestion of toxic amounts of alcohol, which can lead to alcohol poisoning, with effects including mental confusion, stupor, coma, inability to be roused, vomiting, seizures, slow or irregular breathing, hypothermia, bluish skin color, and paleness, and, if left untreated, seizures, permanent brain damage, and/or death.
- Premature births and low birth weights; alcohol and illicit drug-related birth defects, including fetal alcohol syndrome (FAS) involving severe physical, mental, and behavioral problems; and in the case of prenatal cocaine exposure, a 1.5 times increased likelihood of needing special education services in school.
- Suicide.
- Long-term health problems including liver disease; heart disease; cancers including those of the mouth, throat, larynx (voice box), breast, rectum, and colon; and pancreatitis.
- Homelessness.

### Prevention and Intervention Programs

The District provides education and maintains programs and services designed to aid students, employees and their families in receiving assistance for alcohol and/or drug abuse problems. Included in these educational and assistive programs and services are:

- Notification of the dangers of drug use and dependency in the class schedule;
- Mental health services provided to students through the Student Health Services; and
- An Employee Assistance Program (EAP) for employees and their families.

### Alcohol and Drug Prohibitions

The unlawful manufacture, distribution, dispensing, possession, or use of alcohol or any controlled substance is prohibited on District property, during District-sponsored field trips, activities or workshops, and in any facility or vehicle operated by the District.

Violation of Board Policy 3550, Drug and Alcohol Free Environment and Drug and Alcohol Abuse Prevention Program, will be addressed by the District. The District will take appropriate action designed to address each specific violation, which may include, but is not limited to:

- Termination of employment,
- Expulsion,
- Referral to Campus Police or other law enforcement agency for prosecution as permitted by law, or
- Mandatory participation in an alcohol or drug abuse assistance or rehabilitation program.

As a condition of employment, employees of the District will have their fingerprints recorded with the California State Department of Justice and any conviction or violations of the law involving drugs and/or alcohol will be reported to Campus Police and to the Office of Human Resource Services pursuant to the requirements of law. In addition, employees must notify the District within five (5) calendar days of any conviction for violation of a criminal drug statute occurring in the workplace. The District is required to report any violations of criminal drug or alcohol statutes that occur in the workplace to the United States Department of Education on an annual basis.

### Information regarding legal sanctions under federal, state, and local laws is available in the following locations:

1. Library
2. Office of Human Resources
3. Office of Student Affairs
4. Student Health Services

### Alcohol/Drug Abuse Counseling, Treatment, Rehabilitation Information

*Referral information and Social Service Directories for Los Angeles and Orange Counties are available in the following locations:*

1. Counseling Center, ext. 2231
2. Student Health Services, ext. 2321

# CAMPUS PHONE EXTENSIONS

**CERRITOS COLLEGE COMMUNICATION CENTER: (562) 860-2451**  
**HOURS: 8:00 am – 7:00 pm, Monday – Thursday; 8:00 am – 4:30 pm, Friday**

QUESTION/PURPOSE	CALL (562) 860-2451	EXT. #
Address change	Admissions and Records Office	2211
Admissions and Records	Admissions and Records Office	2211
Assessment/Placement Testing	Multi-Purpose Building	2599
Bookstore	Bookstore	2450
CalWORKs	CalWORKs Office	2593
Career Services	Career Services Center	2356
Child Care	Child Development Center	2583
Community Education	Community Education	5050
Counseling	Counseling Services	(562) 467-5231
Distance Education Courses	Distance Education Program	7891
Emergencies	Campus Police	Use emergency phone or dial 911*
Enrollment	Admissions and Records Office	2211
Extended Opportunities Programs and Services	EOPS	2398
Financial Aid and Scholarships	Financial Aid	2397
International Student Advisement	Office of International Student Services	2133
Job Placement	Career Services Center	2366
Library	Library	2430
Lost and Found	Campus Police	2325
Parking Information	Campus Police	2325
Personal Counseling	Student Health Services	2321
Police Department	Campus Police	2325
Reentry Program	Career Services Center	2362
Refunds	Admissions and Records Office	2211
Student Accessibility Services	Student Accessibility Services	2335
Student Body Activities	Office of Student Affairs	2473
Student Conduct and/or Grievance Information	Office of Student Affairs	2483
Student Health Services	Student Health Services Center	2321
Student ID Center	Admissions & Records Office	2120
Transfer Center	Counseling Services/Administration Building	2154
Tutoring	Success Center	7891
Veterans Education	Veterans Resource Center	3716
Withdrawing from College	Admissions and Records Office	2211
<b>DIVISIONS</b>		
Business, Humanities & Social Sciences Divison	Business Education Building	2752
Counseling Division	Administration Building	(562) 467-5231
Fine Arts & Communications Division	Fine Arts Building	2600
Health Occupations Division	Health Science Building	2550
Kinesiology Division	Physical Education Building	2859
Liberal Arts Division	Liberal Arts/DSPS Building	2858
Science, Engineering & Mathematics Division	Physical Science & Technology Building	2660
Technology Division	Physical Science & Technology Building	2900

**Emergency phones are found in the following locations and are to be used for emergency purposes only. These phones are a direct line to the campus police department; therefore, when using them please be sure to: identify yourself when placing the call — identify the nature and location of the emergency.**

Administration Building	Admissions and Records Office Records Room (Vault) only
Burnight Center Building	Lobby/Elevator, Music Wing/Elevator
Business Education Building	North Wing, South Wing
Cafeteria	Student Center
Classroom Building	Hallway
Fine Arts Complex	1st and 2nd Floors, Next to the Elevators
Gym	1st and 2nd Floors, Next to the Elevators
Health Science Building	1st, 2nd, and 3rd Floors, East Elevator, West Elevator
Liberal Arts/DSPS Building	Intercoms, 1st and 2nd Floors Next to Elevators
Library	Elevator East Wing
LRC	Near Center Elevator of Upper/Lower Levels
Math/CIS Building	1st and 2nd Floors, Next to the Elevators
Multi-Purpose Building	1st Floor, East Exterior near Men's Restroom; 2nd Floor, West End
Physical Education Building	1st and 2nd Floors, Next to the Elevators
Physical Science & Technology Building	1st Floor, West End/East End; 2nd Floor, West End/East End
Science Building	1st and 2nd Floors
Skills Lab	West End/East End
Social Science Building	1st, 2nd, and 3rd Floors, Elevator
Weight Training Room	Near Room 3

**The emergency phones can be used for any of the following: emergencies, escorts, medical aid, reports of a crime, keys locked in car. From cell phones, reach Campus Police by calling (562) 402-3674 (for 911 emergency calls only).**

# FINAL EXAM SCHEDULE/ FALL 2020

## LOCATION

Examinations will be conducted in the same room used for the regular class meeting.

## WEEKEND CLASSES

Saturday and Sunday classes will hold a two-hour final exam on December 12 and 13 on the regular class day, beginning at the regular class time.

Final examinations for all day classes will be held according to this schedule. On the chart below, find the appropriate square which identifies the starting day and time for your class during the regular semester. From this you can determine the date and two-hour time block for your final exam. Check with your instructor if your class day or start time does not appear on this final exam schedule.

### LAST DAY OR EVENING FOR CLASSROOM INSTRUCTION IS FRIDAY, DECEMBER 18.

EXAM TIME	DECEMBER 14 Monday	DECEMBER 15 Tuesday	DECEMBER 16 Wednesday	DECEMBER 17 Thursday	DECEMBER 18 Friday
6 AM TO 8 AM	6:00 MTWTH 6:30 MW	6:30 TTH	6:30 DAILY	6:30 TH	6:30 F
8 AM TO 10 AM	7:00 MW 7:00 MTWTH 7:30 MW 8:00 M 8:00 MW 8:30 MW	7:00 TTH 7:15 TTH 7:30 TTH 8:00 T 8:30 T	7:00 MWF 8:00 W 8:00 WF 8:00 DAILY 8:30 WF	8:00 TH 8:00 TTH 8:00 MTWTH 8:30 TTH 8:30 DAILY	7:30 F 8:00 F 8:00 MWF 8:30 MF 8:30 F
10 AM TO 12 PM	9:00 M 9:00 MTWTH 9:30 M 10:00 M 10:00 MW 10:30 MWF 10:30 MTWTH	9:00 T 9:00 TTH 9:30 T 9:30 TTH 9:45 TTH 10:00 T	9:00 W 9:00 MW 9:00 MWF 9:30 W 9:30 MW 10:00 WF	9:00 TH 9:00 TWTH 9:30 TH 10:00 TTH 10:30 TTH	9:00 F 9:30 F 10:00 F
12 PM TO 2 PM	11:00 M 11:00 MW 11:00 MTH 11:30 M 11:30 MW 11:30 MTWTH 12:00 M 12:00 MW 12:30 M	11:00 T 11:00 TTH 12:00 T 12:00 MTWTH 12:30 T 12:30 MTWTH	11:00 W 11:00 WF 11:00 MWF 12:00 W 12:00 MWF 12:30 W 12:30 MW 12:30 WF	11:00 TH 11:30 TH 12:00 TH 12:00 TTH 12:30 TH 12:30 MTH 12:30 TTH 12:30 WTH	11:00 F 12:00 F 12:30 F 12:00 DAILY 12:30 DAILY
2 PM TO 4 PM	1:00 M 2:00 M 2:00 MW 2:00 MWF 2:00 DAILY 2:30 M 2:30 MW	1:00 T 1:00 TTH 1:30 T 1:30 TTH 2:00 T 2:30 T 2:30 TTH	1:00 W 1:00 MW 1:00 MWF 1:30 W 1:30 MW 2:00 W	1:00 TH 1:00 DAILY 1:00 MTWTH 1:30 MTWTH 2:00 TH 2:00 TTH 2:00 MTWTH 2:30 TH	1:00 F 1:00 MF 1:00 WF 1:30 F 2:00 F 2:00 MWF 2:30 DAILY
4 PM TO 6 PM	3:00 M 3:00 MW 3:00 MTWTH 3:15 MW 3:30 M 3:30 MW 3:30 MTWTH 4:00 M	3:00 T 3:00 TTH 3:30 T 3:30 TTH 4:00 T 4:00 DAILY	3:00 W 3:00 MWF 3:30 W 4:00 W 4:00 MW 4:00 MTWTH 4:30 MW	3:00 TH 3:30 TH 4:00 TH 4:00 TTH 4:30 TTH	3:00 F 3:00 DAILY 4:00 F 4:30 WF 4:30 DAILY
<b>EXTENDED DAY FINALS</b>					
6 PM TO 8 PM	5:00 M 5:00 MW 5:30 M 6:00 M 6:00 MW 6:30 M 6:30 MW	5:00 T 5:30 T 5:30 TTH 6:00 T 6:00 TTH 6:30 T 6:30 TTH	5:00 W 5:30 W 5:30 MW 6:00 W 6:30 W	5:00 TH 5:00 TTH 5:30 TH 5:30 MTWTH 6:00 TH	5:00 F 5:00 MF 5:30 F 6:00 F 6:30 F
8 PM TO 10 PM	7:00 M 7:00 MW 7:00 MTWTH 7:30 M 7:30 MW 8:00 M 8:00 MW	7:00 T 7:00 TTH 7:30 T 7:30 TTH 8:00 T 8:00 TTH 8:30 TTH	7:00 W 7:00 WTH 7:30 W	7:00 TH 7:00 THF 7:30 TH	7:00 F 7:30 F

### SPECIAL SITUATIONS:

- These exam times are subject to change and will be announced by instructors.
- Classes scheduled for a double period on one day and a single period another day (e.g. 8 - 10 T Th and 9 Th) will have the final examination scheduled for that hour (8) on which the class meets both days (T Th) (for example, exam will be from 8 - 10 T).
- Classes scheduled in a block on a single day (e.g. 9 - 12 T or 12 - 4 F) will take the final examination scheduled for the first hour on which the class meets (for example, exam time will be from 10 - 12 T for the 9 - 12 T class and 12 - 2 F for the 12 - 4 F class).
- Students whom because of personal illness are unable to take examinations as scheduled must make individual arrangements with the instructor involved.

# CAMPUS MAP

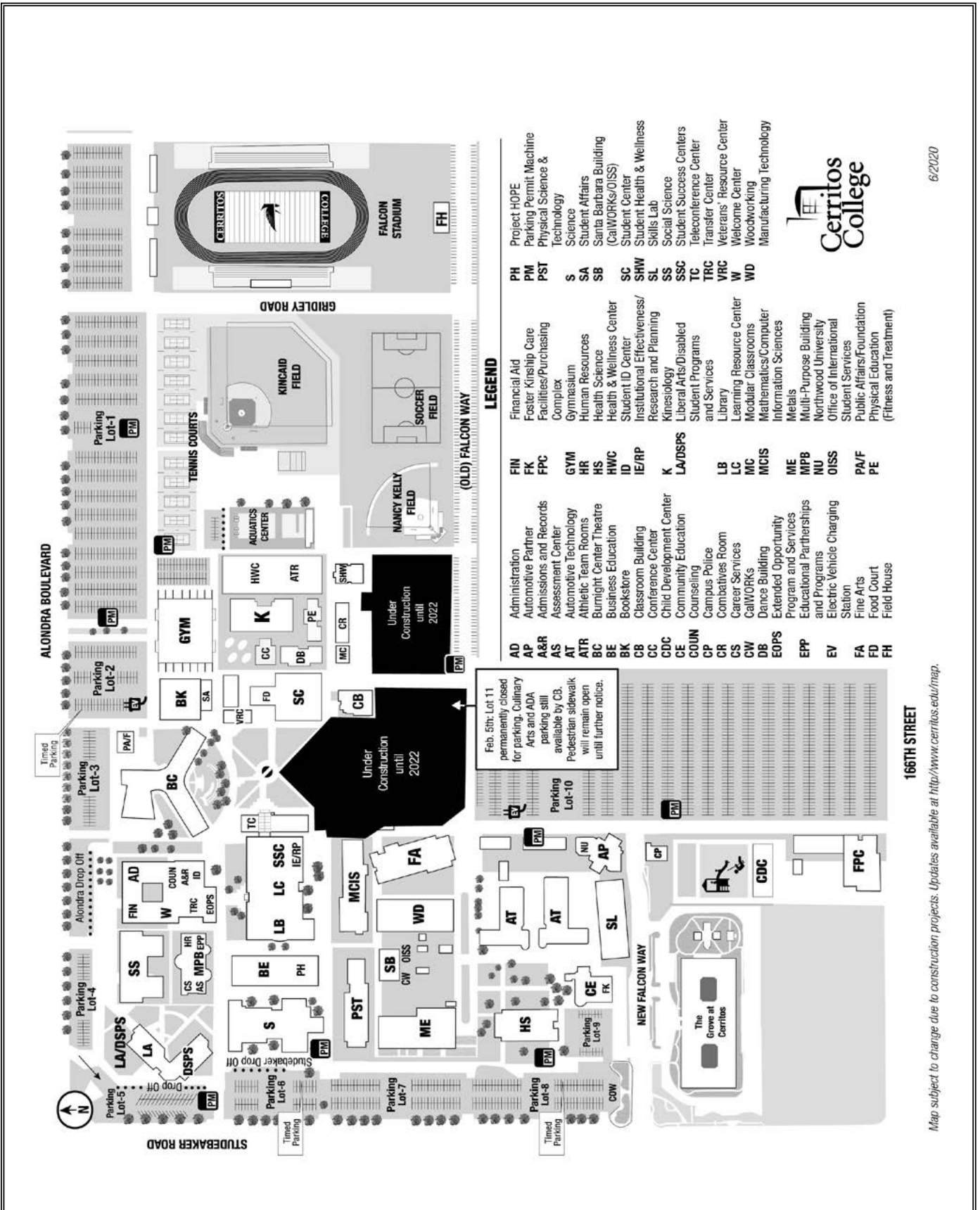

### LEGEND

AD	Administration	AD	Project HOPE
AP	Automotive Partner	AP	Parking Permit Machine
A&R	Admissions and Records	PM	Physical Science & Technology
AS	Assessment Center	PST	Science
AT	Automotive Technology	S	Student Affairs
ATR	Athletic Team Rooms	SA	Santa Barbara Building (Ca/WORKS/OISS)
BC	Burnight Center Theatre	SB	Student Center
BE	Business Education	SC	Student Health & Wellness
BK	Bookstore	SHW	Skills Lab
CB	Classroom Building	SL	Social Science
CC	Conference Center	SS	Student Success Centers
CDC	Child Development Center	SSC	Teleconference Center
COUN	Community Education	TC	Transfer Center
CP	Counseling	TRC	Veterans' Resource Center
CR	Campus Police	VRC	Welcome Center
CR	Combatives Room	W	Woodworking
CS	Career Services	WD	Manufacturing Technology
CW	Ca/WORKS		
DB	Dance Building		
EOPS	Extended Opportunity Program and Services		
EPP	Educational Partnerships and Programs		
EV	Electric Vehicle Charging Station		
FA	Fine Arts		
FD	Food Court		
FH	Field House		
FA	Financial Aid	FK	Foster Kinship Care
FB	Facilities/Purchasing Complex	FPC	Gymnasium
FC	Human Resources	GYM	Health & Wellness Center
FD	Health Science	HR	Human Resources
FE	Health & Wellness Center	HS	Health & Wellness Center
FF	Institutional Effectiveness/Research and Planning	HWC	Health & Wellness Center
FG	Kinesiology	ID	Student ID Center
FH	Liberal Arts/Disabled Student Programs and Services	IE/RP	Institutional Effectiveness/Research and Planning
FI	Library	K	Kinesiology
FJ	Learning Resource Center	LA/DSPS	Liberal Arts/Disabled Student Programs and Services
FK	Modular Classrooms	LB	Library
FL	Mathematics/Computer Information Sciences	LC	Learning Resource Center
FM	Metals	MC	Modular Classrooms
FN	Multi-Purpose Building	MCIS	Mathematics/Computer Information Sciences
FO	Northwood University	ME	Metals
FP	Office of International Student Services	MPB	Multi-Purpose Building
FQ	Physical Education (Fitness and Treatment)	NU	Northwood University
FR	Public Affairs/Foundation	OISS	Office of International Student Services
FS	Physical Education (Fitness and Treatment)	PA/F	Public Affairs/Foundation
FT	Physical Education (Fitness and Treatment)	PE	Physical Education (Fitness and Treatment)



6/2020

166TH STREET

Map subject to change due to construction projects. Updates available at <http://www.cerritos.edu/map>.

## EASY REFERENCE COURSE LISTINGS

<b>COURSE</b>	<b>PAGE</b>	<b>COURSE</b>	<b>PAGE</b>
<b>A</b>			
Access Learning . . . . .	32	Interdisciplinary Studies . . . . .	69
Accounting . . . . .	32	<b>J</b>	
Administration of Justice . . . . .	33	Japanese . . . . .	69
Adult Education . . . . .	105	Journalism . . . . .	70
American Sign Language . . . . .	34	<b>K</b>	
Anatomy and Physiology . . . . .	34	Kinesiology . . . . .	70
Anthropology . . . . .	35	<b>L</b>	
Architecture . . . . .	35	Law . . . . .	71
Art and Design . . . . .	35	Library . . . . .	72
Astronomy . . . . .	39	<b>M</b>	
Athletics . . . . .	39	Machine Tool Technology . . . . .	72
Autobody/Collision and Repair . . . . .	40	Mathematics . . . . .	73
Automotive Technology . . . . .	41	Medical Assisting . . . . .	76
<b>B</b>			
Biology . . . . .	42	Microbiology . . . . .	77
Business Administration . . . . .	42	Music . . . . .	77
Business Communications . . . . .	46	<b>N</b>	
<b>C</b>			
Chemistry . . . . .	47	Nursing . . . . .	80
Child Development . . . . .	48	<b>P</b>	
Chinese . . . . .	48	Paralegal (see Law) . . . . .	71
Communication Studies (Formerly Speech) . . . . .	49	Pharmacy Technology . . . . .	81
Computer and Information Sciences . . . . .	50	Philosophy . . . . .	82
Cosmetology . . . . .	52	Photography . . . . .	82
Counseling . . . . .	53	Physical Education . . . . .	83
Culinary Arts . . . . .	54	Physical Science . . . . .	87
<b>D</b>			
Dance . . . . .	55	Physical Therapist Assistant . . . . .	87
Dental Assisting . . . . .	56	Physics . . . . .	87
Dental Hygiene . . . . .	57	Plastics/Composites . . . . .	88
Drafting (see Engineering Design Technology) . . . . .	60	Political Science . . . . .	88
<b>E</b>			
Earth Science . . . . .	57	Psychology . . . . .	89
Economics . . . . .	58	<b>R</b>	
Education . . . . .	59	Radio-Television . . . . .	90
Educational Technology . . . . .	59	Reading and Study Skills . . . . .	91
Engineering . . . . .	59	Real Estate . . . . .	91
Engineering Design Technology . . . . .	60	<b>S</b>	
Engineering Technology . . . . .	60	Sociology . . . . .	91
English . . . . .	60	Spanish . . . . .	92
English as a Second Language . . . . .	64	Speech (see Communication Studies) . . . . .	49
<b>F</b>			
Film . . . . .	65	Speech-Language Pathology . . . . .	93
Finance . . . . .	66	<b>T</b>	
French . . . . .	66	Theatre Arts . . . . .	93
<b>G</b>			
Geography . . . . .	66	<b>W</b>	
Geology . . . . .	67	Welding . . . . .	94
German . . . . .	67	Women's and Gender Studies . . . . .	95
<b>H</b>			
Health Education . . . . .	67	Woodworking . . . . .	96
Health Occupations . . . . .	68	<b>Z</b>	
History . . . . .	68	Zoology . . . . .	97
Humanities . . . . .	69		

Grace Espejo  
UCI Fall 2020 Transfer  
Major: Psychology



# CSU/UC TRANSFER PROCESS

## FALL 2020 – FALL 2021

### APPLICATION DEADLINES

#### January 2020

Update UC application including fall 2019 grades and spring 2020 coursework.  
Send the CSUs official transcripts showing fall 2019 grades (all fall 2020 applicants).  
Fall 2020/spring 2021 transfers, apply for financial aid by completing the FAFSA form online at [www.fafsa.gov](http://www.fafsa.gov) (list up to 10 CSU/UC/private universities on the form).

#### July 2020

UC applicants submit official transcripts from all institutions to UC campus of choice to include spring grades by July 1.

#### July 1 – 31, 2020

UC application priority filing period for winter quarter 2021 applicants, if open. Begin brainstorming on UC personal insight questions.

#### February/March 2020

By submitting the FAFSA or Dream Act Application and the G.P.A. verification form by March 2, you may be eligible to receive a Cal Grant.  
For more information go to [www.cerritos.edu/finaid](http://www.cerritos.edu/finaid).  
Keep checking email for university updates.

#### August 1–31, 2020

CSU application priority filing period for spring semester 2021 applicants, if open. UC application for fall 2021 opens. Begin scholarship research and applications.  
[apply.universityofcalifornia.edu](http://apply.universityofcalifornia.edu)

#### April 2020

Fall 2020 CSU/UC admissions letters sent or check online at campus websites.

#### September 2020

Continue scholarship research and applications. UC TAG filing period fall 2021.  
[uctap.universityofcalifornia.edu](http://uctap.universityofcalifornia.edu)

#### May 2020

Fall 2020 CSU Statement of Intent to Register due by May 1st.  
Attend Transfer Celebration  
CSU applicants send another official transcript with spring grades to CSU campuses; once admitted, request GE certification from Admissions & Records for the intended CSU/UC campus.

#### October 1 – November 30, 2020

CSU application priority filing period for fall 2021 semester/quarter applicants. Attend CSU application workshops.  
[www.calstate.edu/apply](http://www.calstate.edu/apply)  
Fall 2021/spring 2022 transfers, apply for financial aid by completing FAFSA form online.

#### June 2020

Fall 2020 UC Statement of Intent to Register due by June 1st. Upon selecting your college, request IGEC certification for Admissions & Records for the intended UC campus.  
IGEC certification due by July 15 (4-6 weeks to process).

#### November 1–30, 2020

UC application priority filing period for fall 2021 semester/quarter applicants. Attend UC application workshops.  
[apply.universityofcalifornia.edu](http://apply.universityofcalifornia.edu)

#### University of California

UC Berkeley  
UC Davis  
UC Irvine  
UC Los Angeles  
UC Merced  
UC Riverside  
UC San Diego  
UC Santa Barbara  
UC Santa Cruz

#### California State University

California Maritime Academy  
CSU Channel Islands  
Chico  
CSU East Bay  
CSU Fresno  
Humboldt State  
Cal Poly Pomona  
Cal Poly San Luis Obispo  
CSU Monterey Bay  
CSU Northridge  
CSU Los Angeles  
CSU Bakersfield  
CSU Dominguez Hills  
CSU Fullerton  
CSU Long Beach  
CSU Sacramento  
San Francisco State  
San José State  
CSU San Marcos  
Sonoma State  
CSU Stanislaus  
CSU San Bernardino  
San Diego State



Located in the Administration Building (AD), West Quad  
Monday through Thursday, 8 a.m. - 7 p.m.;  
Friday, 8 p.m.–2 p.m. (excluding summer)  
Office hours are subject to change.  
(562) 860-2451, ext. 2154 • [www.cerritos.edu/transfer](http://www.cerritos.edu/transfer)