



# Multiple Measures

COMMON ASSESSMENT AND HIGH SCHOOL TRANSCRIPTS

# Multiple Measures

- ▶ Using more than one tool to place students in Math, English, ESL, and Reading
  - ▶ Tool 1: Common Assessment
  - ▶ Tool 2: High School Transcript
  - ▶ Tool 3: California Assessment of Student Performance and Progress

# Common Assessment

- ▶ Statewide Initiative
- ▶ Consistent Across Campuses
  - ▶ Common Assessment, Not Common Placement
- ▶ Piloted at 12 Campuses across the State
- ▶ We are mapping competencies for Math, English, ESL, and Reading
- ▶ If pilot is successful, we may implement as early as fall of 2018

# High School Transcripts

- ▶ Service-Area Schools submit their student data
- ▶ Math and English have established their criteria, a slight modification of the Multiple Measure Assessment Project Criteria
- ▶ Pilot GPA placement through Cerritos Complete, AIME, and EOPS
- ▶ Collect data to validate our Multiple Measures
- ▶ AB 705

# Innovations in Math

- ▶ Common Assessment
- ▶ High School Transcripts
- ▶ Dual Enrollment
- ▶ Math 75—Stats Path for Non-STEM Majors
- ▶ Flexible Class Offerings
  - ▶ 9, 15, and 18 Week Courses
  - ▶ Online Classes
  - ▶ Weekend College
  - ▶ Semi-Independent Classes
- ▶ AIME
- ▶ Embedded Tutors

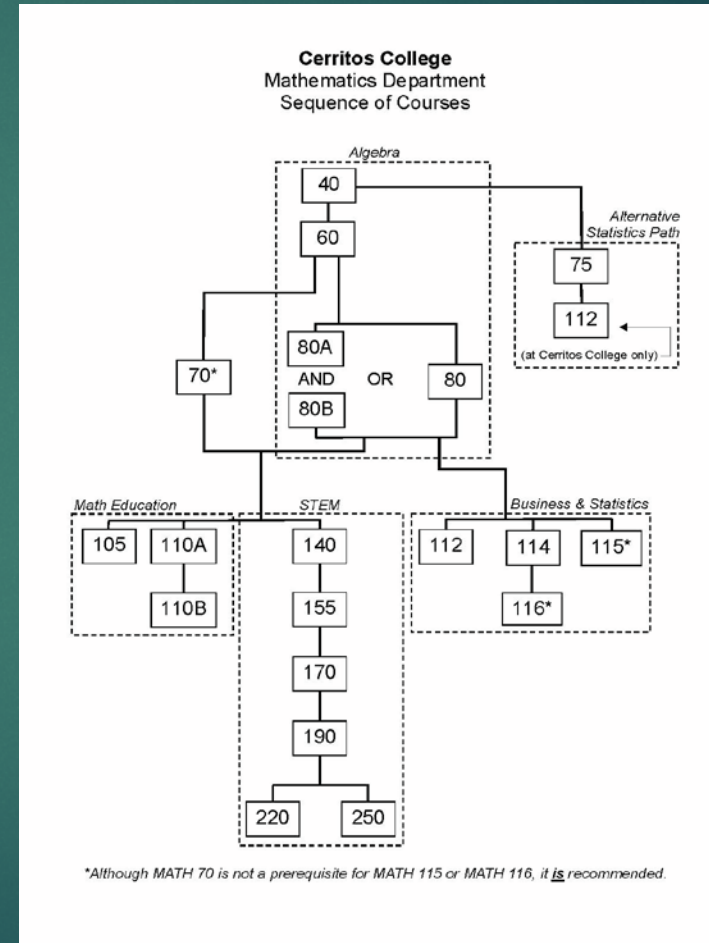

# Innovations in English

- ▶ ERWC Placement
- ▶ Common Assessment
- ▶ High School Transcripts
- ▶ Dual Enrollment
- ▶ Co-requisite Course—English 100 + English 5L
- ▶ Accelerated Course—English 72
- ▶ 9, 15, 18 Week Courses
- ▶ AIME Program
- ▶ Embedded Tutors